

ASSEMBLY INSTRUCTION

Remove all items from the carton. Verify all pieces before assembly

PART	QTY		PART	QTY		PART	QTY	
①	1	Star Base	⑦	1	Right Arms	D	4	Washer
②	1	Cylinder Column	A	4	Allen Bolt 6 x 25 x10 mm	E	1	Allen Wrench
③	1	Control Mechanism	B1	2	Allen Bolt 6 x 20 x 10 mm	F	5	Caster
④	1	Seat	B2	2	Allen Bolt 6 x 30 x10 mm	G	2	Cap Cover (Upper)
⑤	1	Back frame	C	4	Allen Bolt 6 x 35 x10 mm	H	2	Cap Cover(Lower)
⑥	1	Left Arms						

NOTE: The discarded packaging for the unit can be used as a helpful way to support it during the assembly process.

STEP 1.

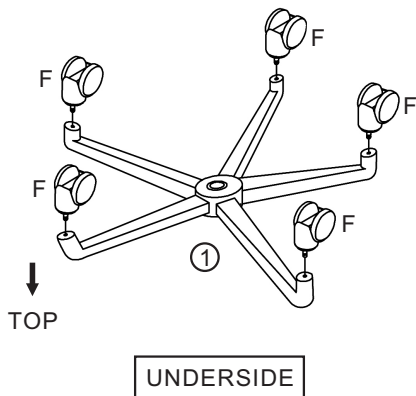

STEP 2.

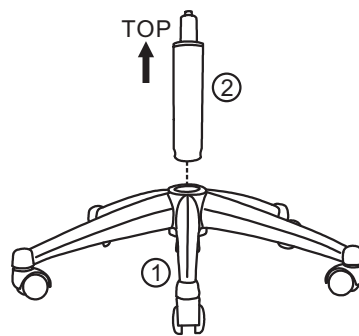

STEP 3.

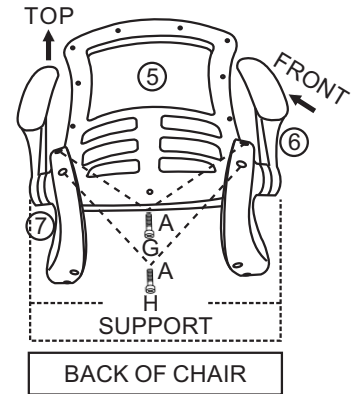

NOTICE:
ATTACH BACK TO ARMS,
AND FULLY TIGHTEN ALL SCREWS.

STEP 4.

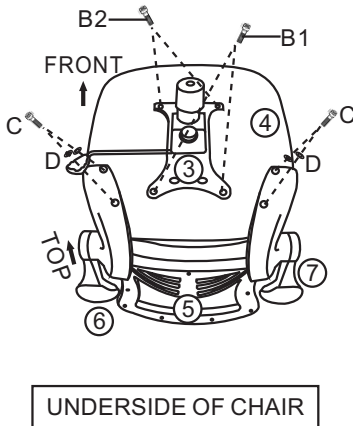

AS WITH ALL MOVABLE MECHANICAL DEVICES;
IT IS ADVISED TO PERIODICALLY CHECK TO
MAKE SURE ALL BOLTS, SCREWS AND KNOBS
ARE FULLY TIGHTENED TO ENSURE STABILITY.

PREVENTIVE MAINTENANCE AND WARNING!

- USE THIS PRODUCT ONLY FOR SEATING ONE PERSON AT A TIME.
- DO NOT USE THIS CHAIR AS A STEP STOOL/LADDER.
- DO NOT SIT ON ANY PART OF THE CHAIR EXCEPT THE SEAT.
- DO NOT USE CHAIR UNLESS ALL BOLTS, SCREWS AND KNOBS ARE TIGHT.
- IT'S ADVISED TO PERIODICALLY CHECK ALL BOLTS, SCREWS AND KNOBS TO BE SURE THEY ARE TIGHT.

- IF ANY PARTS ARE MISSING, BROKEN, DAMAGED OR WORN, STOP USE OF THE PRODUCT UNTIL REPAIRS ARE MADE USING FACTORY AUTHORIZED PARTS.
- WARNING: TO AVOID DANGER OF SUFFOCATION, KEEP THIS PLASTIC BAG AWAY FROM BABIES & CHILDREN. DO NOT USE THIS BAG IN CRIBS, BEDS, CARRIAGES, PLAY PENS OR AS HEAD COVERING.
- FAILURE TO FOLLOW THESE WARNINGS COULD RESULT IN SERIOUS INJURY.

Office Chair - EEI-210 KEEP THIS PAGE FOR FUTURE REFERENCE.