





# ASSEMBLY INSTRUCTION

## CROWN MARK



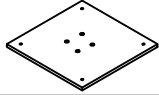



MODEL:

ROUND DINING TABLE

### BOX 1 (TABLE TOP)

|   |   |               |      |
|---|---|---------------|------|
| 1 |  | CONNECT BOARD | 1 PC |
| 2 |  | TABLE TOP     | 1 PC |
| 3 |  | LEG           | 1 PC |
| 4 |  | SUPPORT LEG   | 1 PC |

### (BOX 1) HARDWARE LIST

|   |  |                   |       |
|---|--|-------------------|-------|
| A |  | Ø5/16"-18x2-1/2"L | 4 PCS |
| B |  | Ø5/16"-18x1-1/2"L | 4 PCS |
| C |  | Ø5/16"            | 1PC   |
| D |  | Ø3/8"             | 4 PCS |
| E |  | Ø3/8"             | 4 PCS |
| F |  | Ø3/8"             | 4 PCS |
| G |  | Ø17mm             | 1 PC  |

### BOX 2 (TABLE LEG)

|   |   |           |      |
|---|---|-----------|------|
| 5 |  | TABLE LEG | 1 PC |
|---|---|-----------|------|

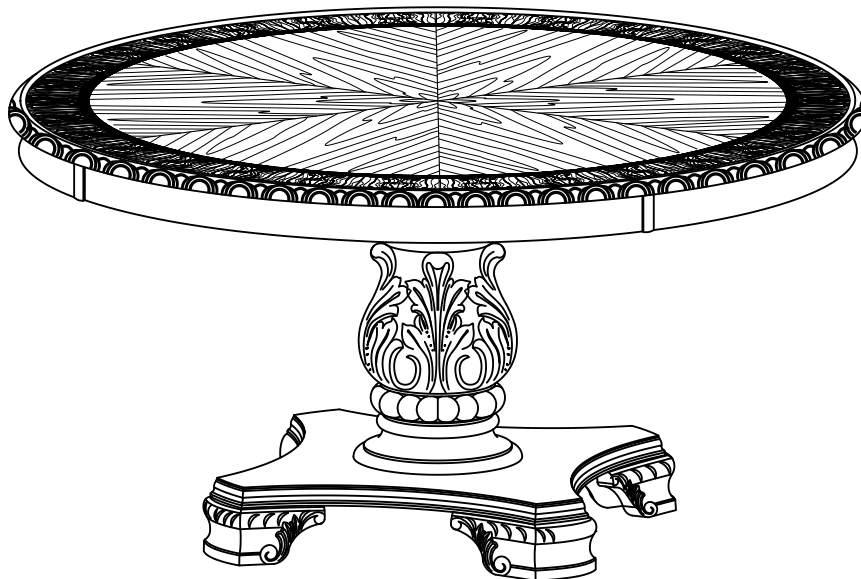

THE HARDWARE IS LOCATED  
IN THE PACKING ITEMS.

**NOTE:**  
DURING ASSEMBLY DO NOT FULLY  
TIGHTEN ANY HARDWARE UNTIL THE  
COMPLETE UNIT HAS BEEN ASSEMBLED.

NOTE: MUST TIGHTEN SCREWS PERIODICALLY WITH USE SCREWS WILL  
BECOME LOOSE. CHECK TIGHTNESS OF ALL SCREWS EVERY 6-8 WEEKS.

# ASSEMBLY INSTRUCTION

## CROWN MARK

MODEL:

ROUND DINING TABLE

Step 1:

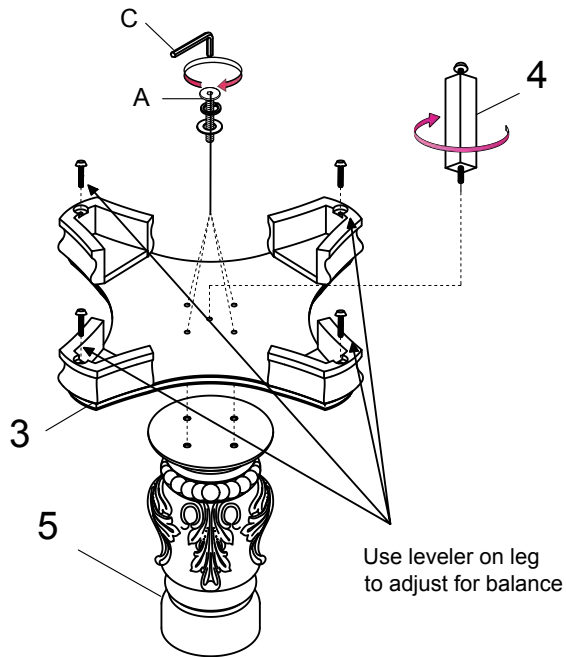

Step 2:

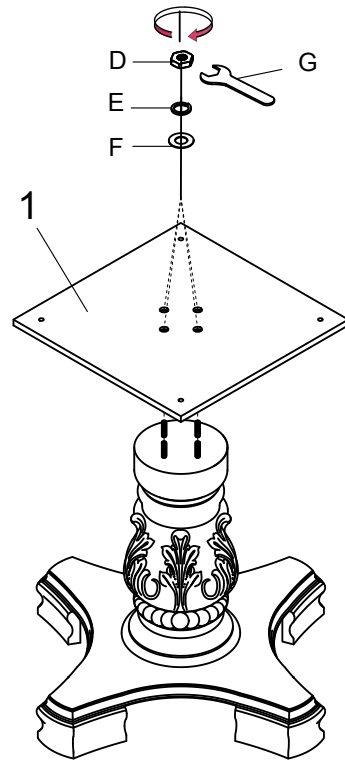

Step 3:

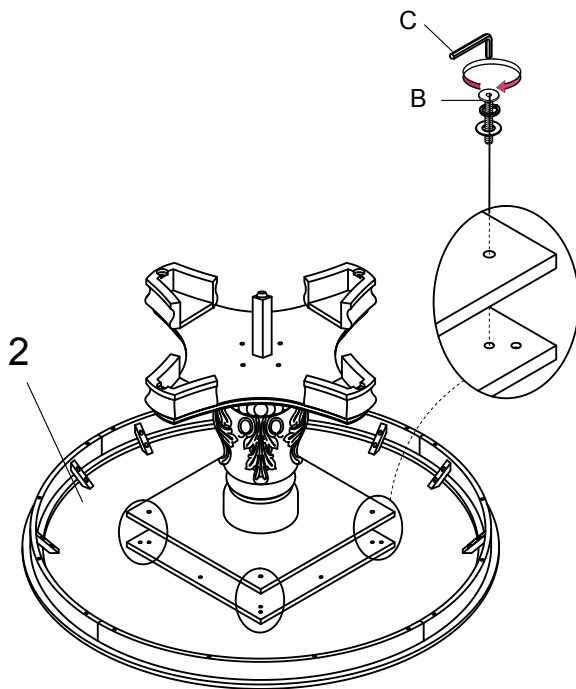

Step 4:



THE HARDWARE IS LOCATED IN THE PACKING ITEMS.

**NOTE:**  
DURING ASSEMBLY DO NOT FULLY TIGHTEN ANY HARDWARE UNTIL THE COMPLETE UNIT HAS BEEN ASSEMBLED.

NOTE: MUST TIGHTEN SCREWS PERIODICALLY WITH USE SCREWS WILL BECOME LOOSE. CHECK TIGHTNESS OF ALL SCREWS EVERY 6-8 WEEKS.