

# DOUBLE LIFTING COFFEE TABLE ASSEMBLY INSTRUCTIONS

Thank you for purchasing the **DOUBLE LIFTING COFFE TABLE**.  
Please read the instructions carefully to ensure safe operation of the product.

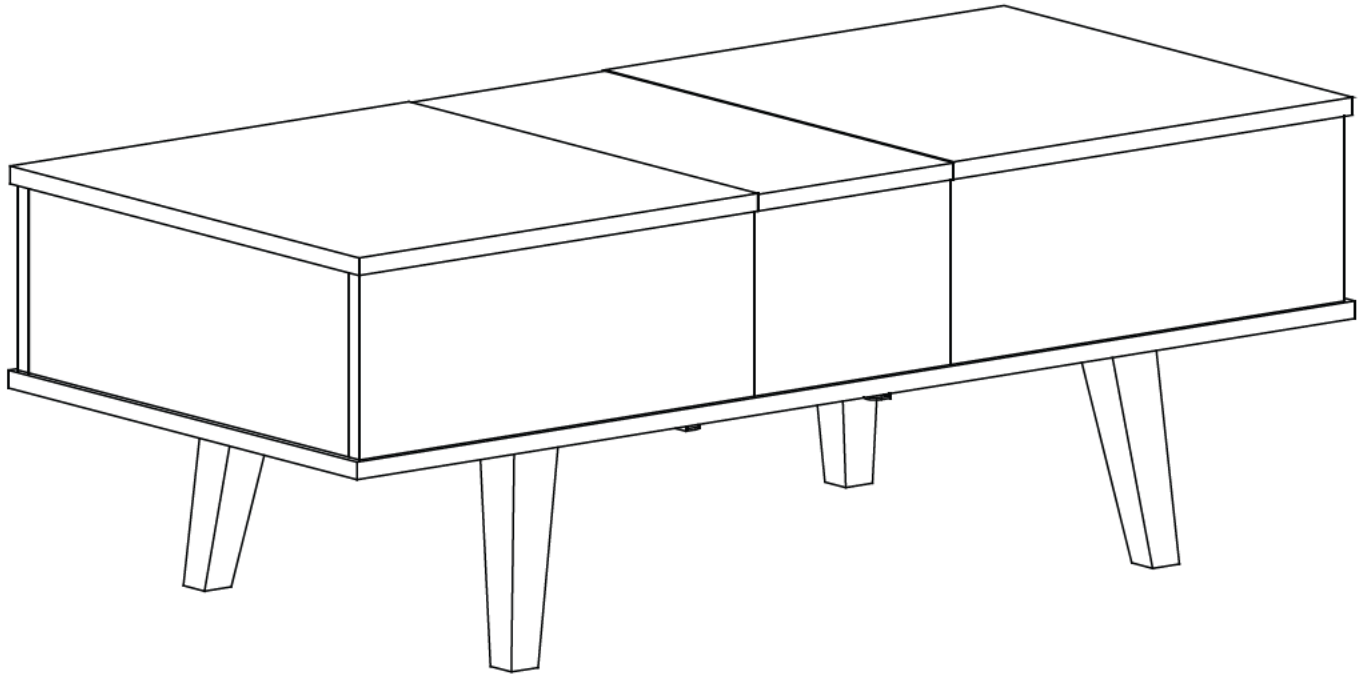

Size: (W)1120 x (D)500 x (H)400mm  
Colour : Melamine Grey

**PLEASE READ** this sheet prior to assembly to familiarise yourself with the various stages of construction.

Carefully open the pack supplied and check the contents against the parts and fittings check list. Do not destroy any of the packaging until you are certain that you have all the necessary parts for the assembly.

**CAUTION:** There are small components used in the construction of this unit. These loose items should be kept away from young children whilst assembling your unit to avoid the danger of choking hazards.

## Tools Required

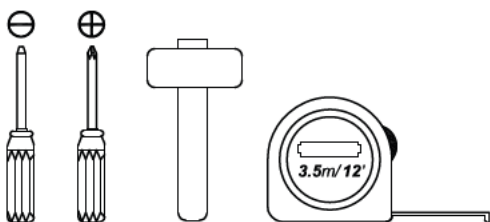

## Person Required



## Approximate Assembly Time



## **IMPORTANT - READ CAREFULLY - RETAIN THESE INSTRUCTIONS FOR FUTURE REFERENCE.**

### **INFORMATION**

- This product is intended for a maximum weight of **25kgs** and drawer load capacity **7kg** each. Do not exceed this weight.
- Due to the size of this product we recommend that is assembled in the room intended for use.
- When you ready to start, make sure that you have the right tools, plenty of space and a clean, dry area for assembly
- Unwrap all packaging materials and place the components on top of the carton box or not on a clean floor to prevent it from scratching.
- Check the pack and make sure you have all the parts listed.
- Ensure that this product is fully assembled as illustrated before use.
- Check all screws or bolts are tightened and inspect regularly.
- This product should only be used on firm, level ground.
- Keep small parts out of reach of children.
- Make sure the legs remain in contact with the ground.
- Tools not included.

### **WARNINGS**

- DO NOT use power tools to construct this product.
- DO NOT over tighten screw or bolts.
- DO NOT use this product if parts are missing, damage or worn.
- DO NOT stand or sit on this coffee table.

### **CARE INFORMATION**

- Never use scourers, abrasives or chemical cleaners.
- To clean wipe with a sponge and soapy water. Do not use solvent based cleaners or detergents as they can bleach or damage the product.

Please check the pack contents before assembling the product. If any components are missing, please contact your retailer. The fittings pack contains small items that should be kept away from small children.

## Parts

CODE	PART NAME	QTY
A	Side Panel (16 x 168 x 458mm)	2
B	Centre Panel (16 x 168 x 458mm)	2
C	Front & Back Panel (16 x 168 x 443 mm)	4
D	Bottom Panel (16 x 500 x 1120mm)	1
E	Centre Panel (15 x 168 x 460mm)	2

CODE	PART NAME	QTY
F	Centre Front & Back panel (15 x 168 x 220mm)	2
G	Fix Panel (15 x 167 x 190mm)	2
H1	Top Lifting Panel (R) (16 x 500 x 448mm)	1
H2	Top Lifting Panel (L) (16 x 500 x 448mm)	1
I	Top Centre Panel (15 x 500 x 220mm)	1

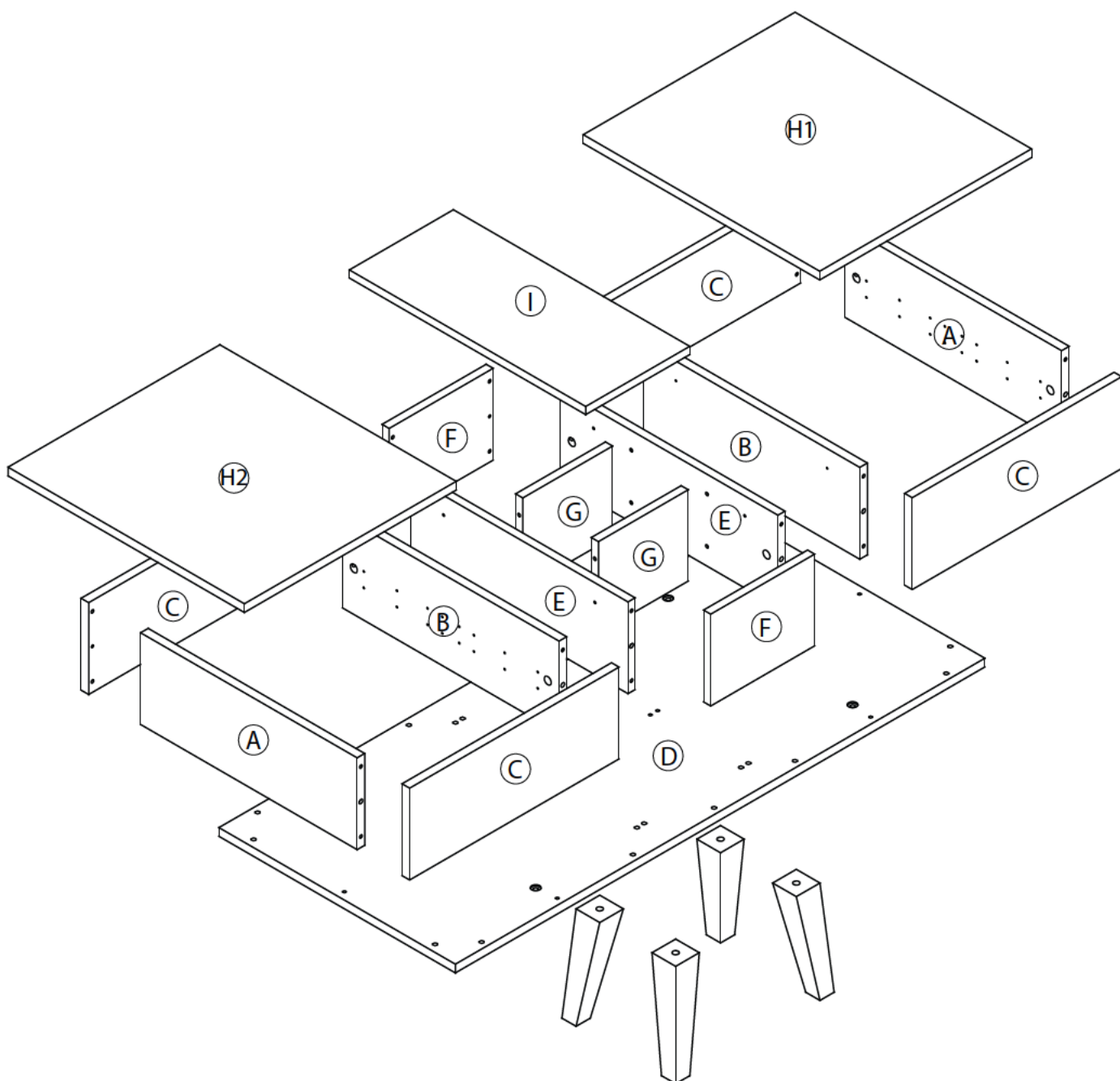

## Fixings (to scale)

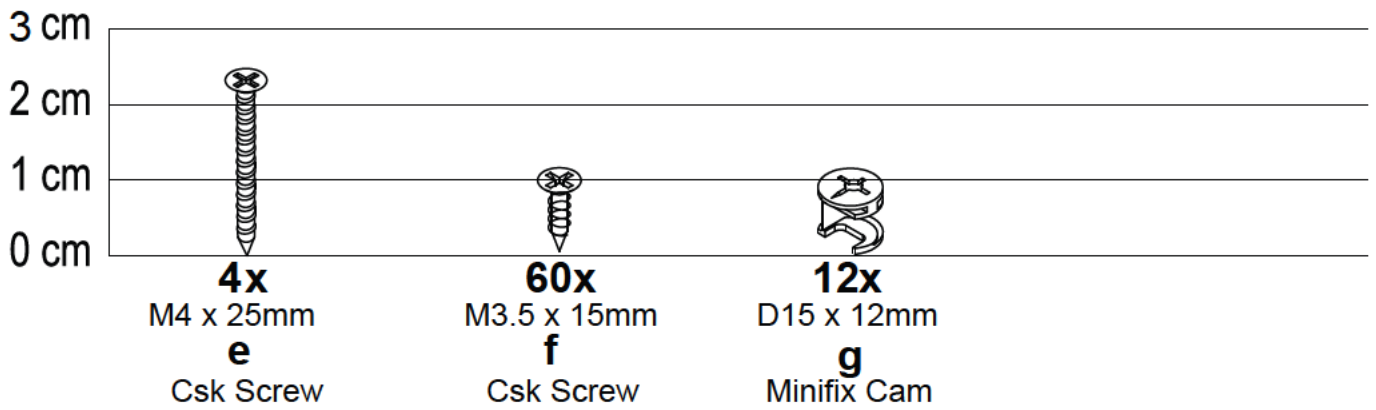
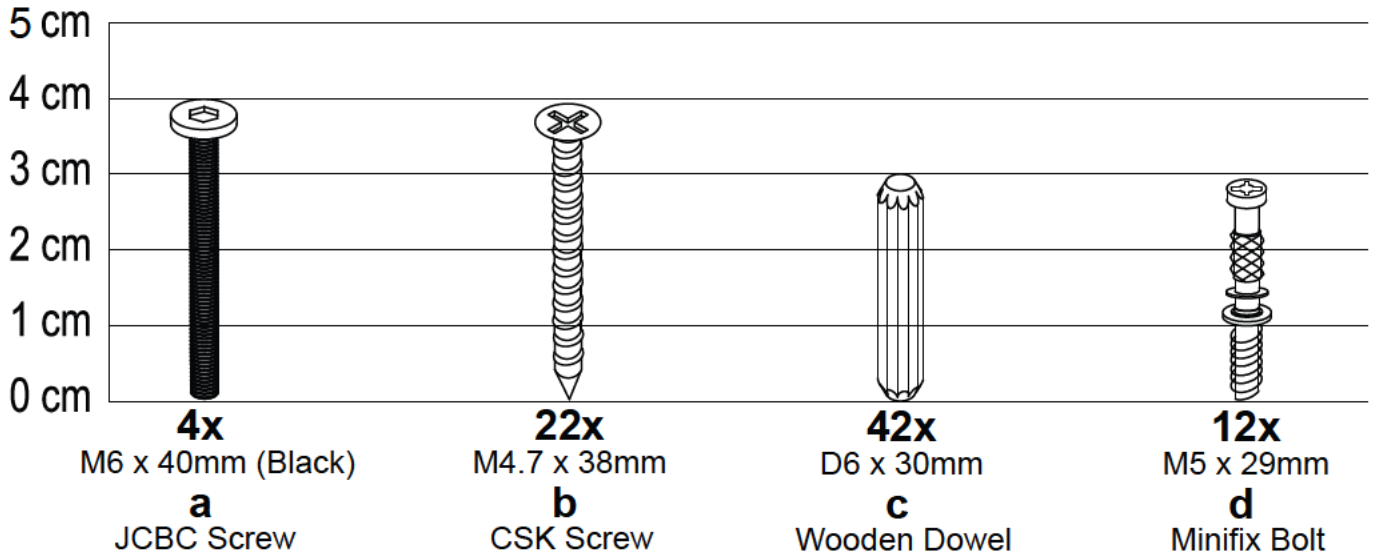

## Fixings (not to scale)

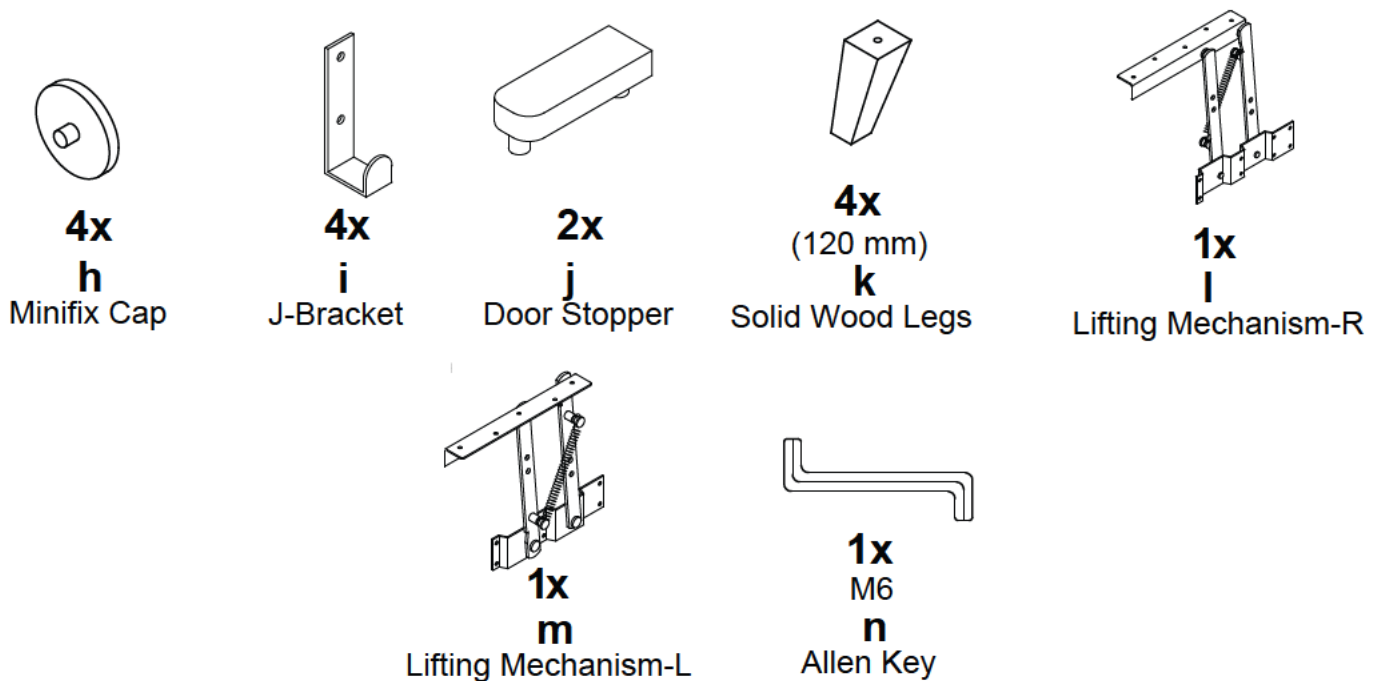

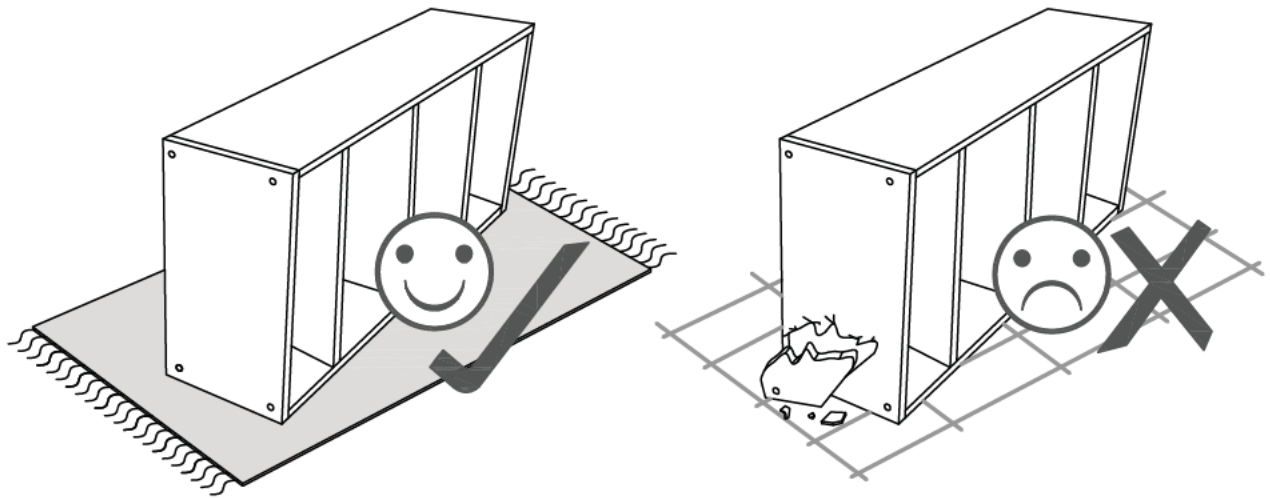

## Layout Parts on Soft Surface

### STEP 1

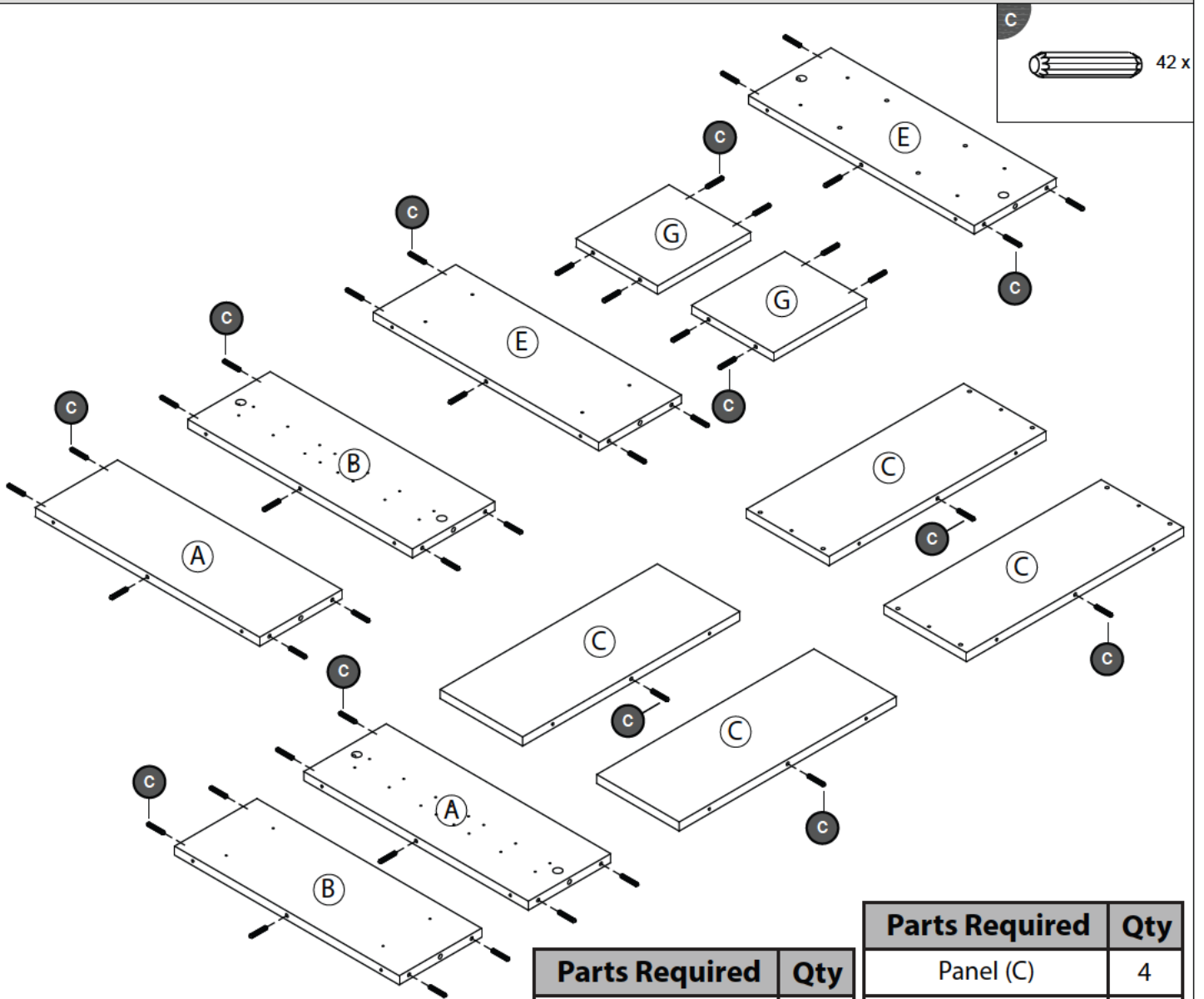

Parts Required	Qty
Panel (A)	2
Panel (B)	2

Parts Required	Qty
Panel (C)	4
Panel (E)	2
Panel (G)	2

## STEP 2

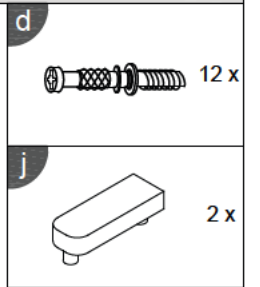
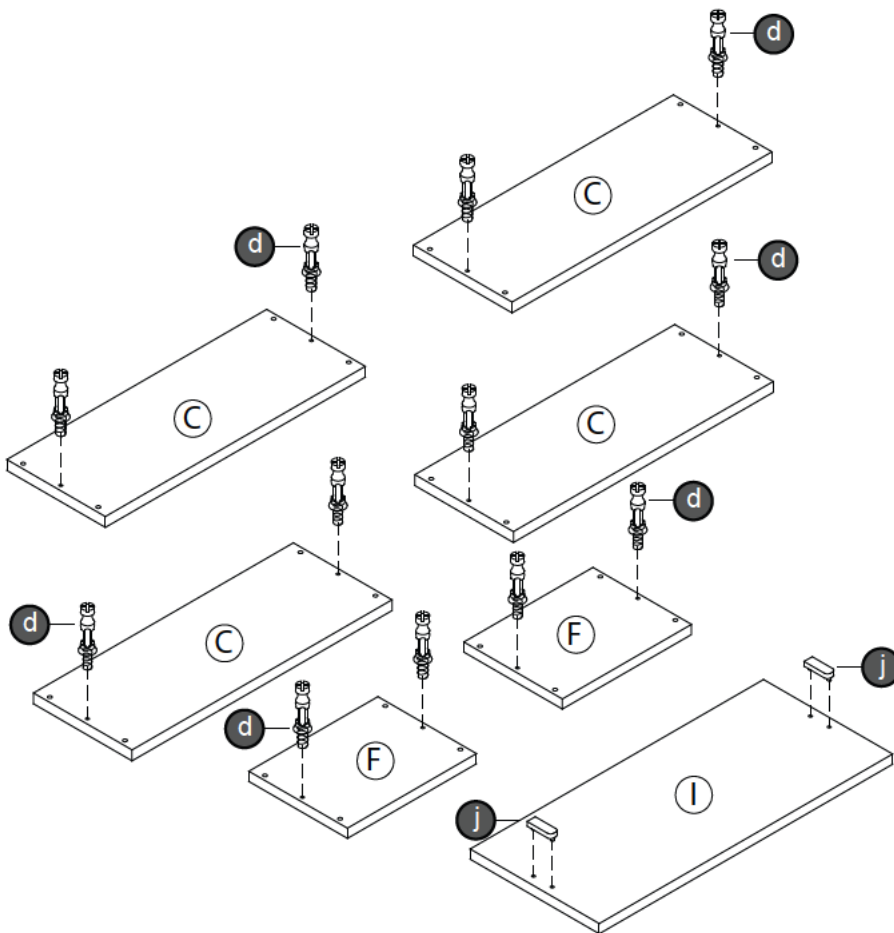

Don't screw too deep

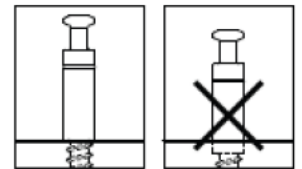

Parts Required	Qty
Panel (C)	4
Panel (F)	2
Panel (I)	1

## STEP 3

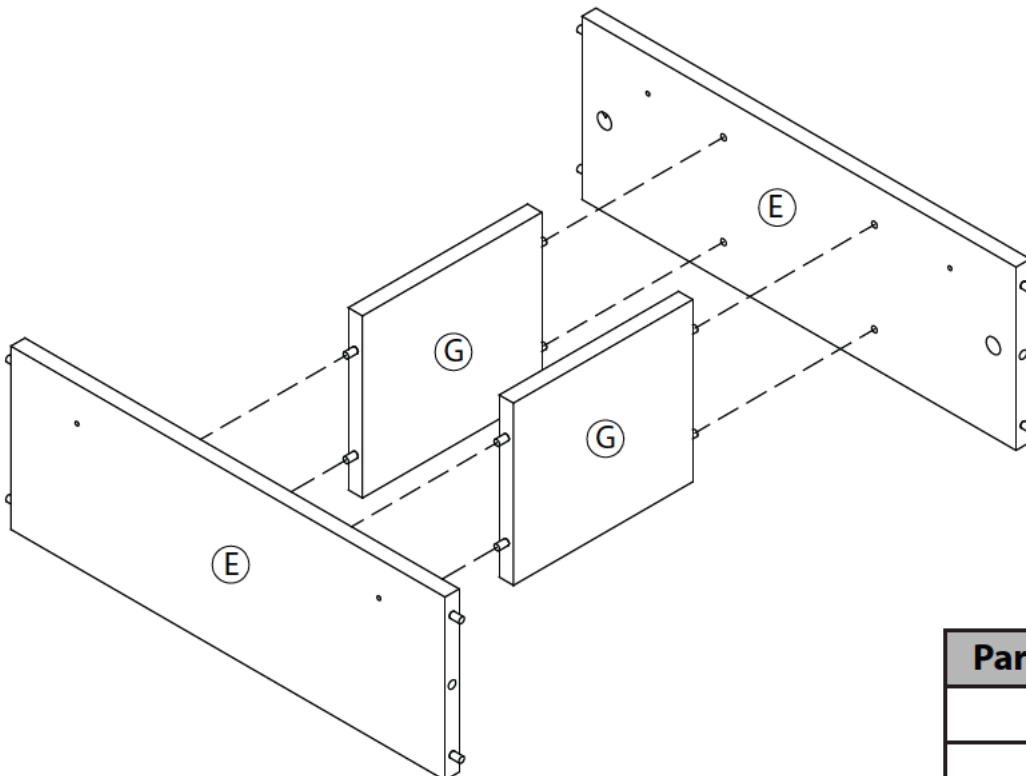

Parts Required	Qty
Panel (E)	2
Panel (G)	2

## STEP 4

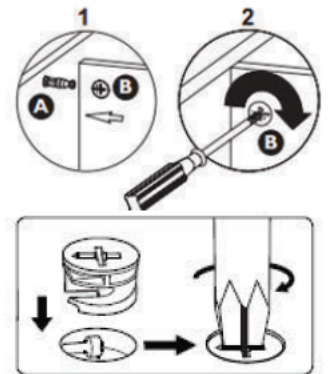
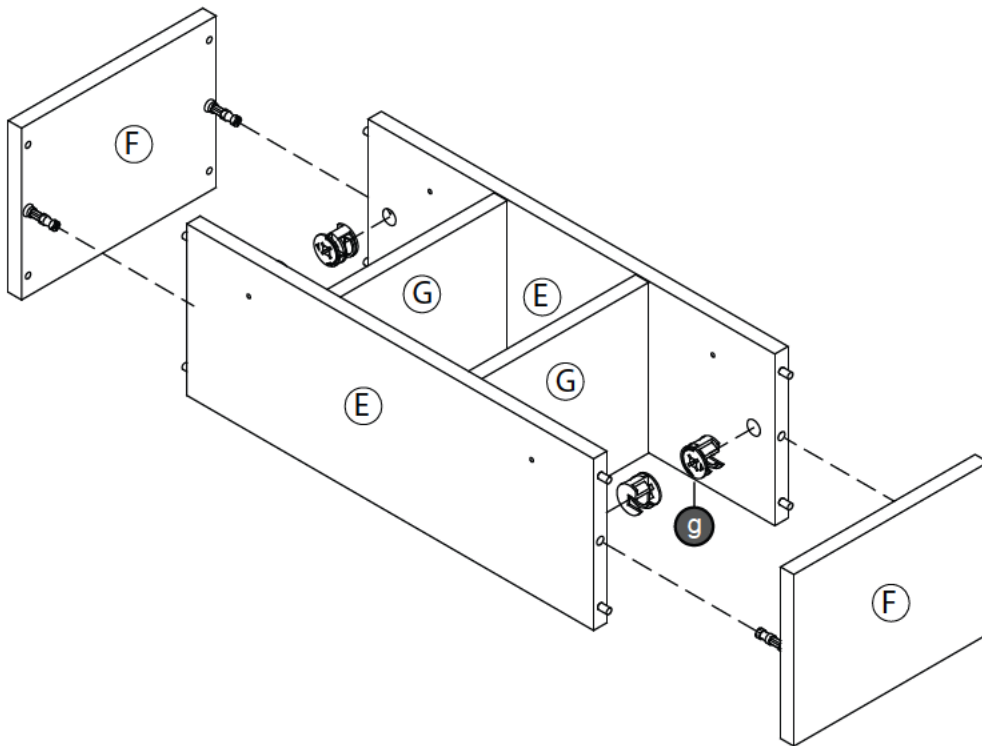

Parts Required	Qty
Panel (F)	2

## STEP 5

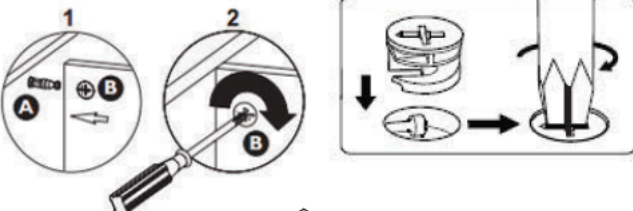
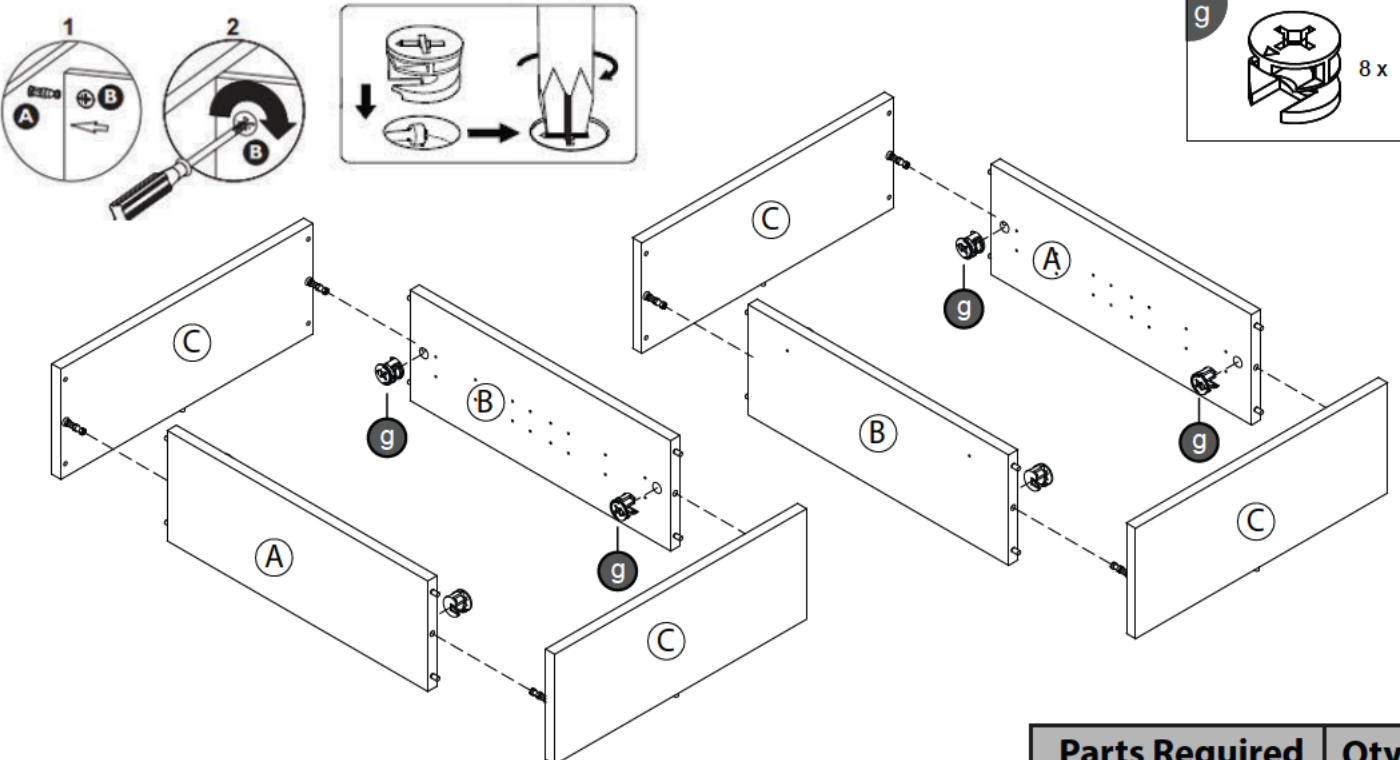

Parts Required	Qty	Parts Required	Qty
Panel (A)	2	Panel (B)	2
Panel (C)	4	Panel (C)	4

## STEP 6

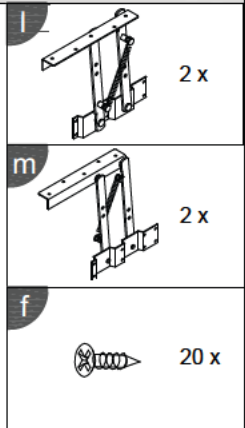
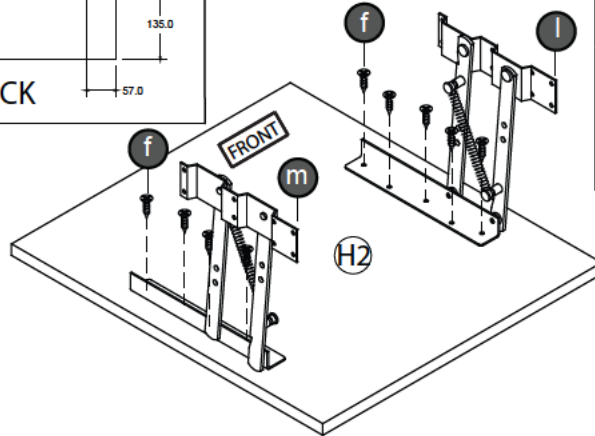
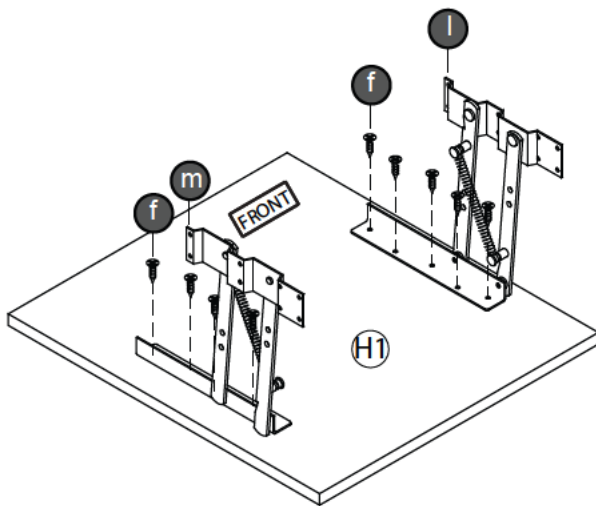
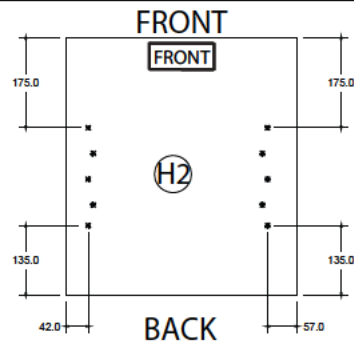
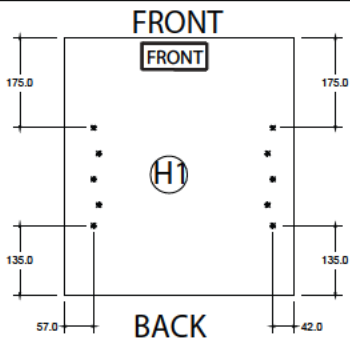

Parts Required	Qty
Panel (H1)	1
Panel (H2)	1

## STEP 7

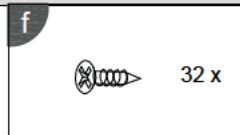
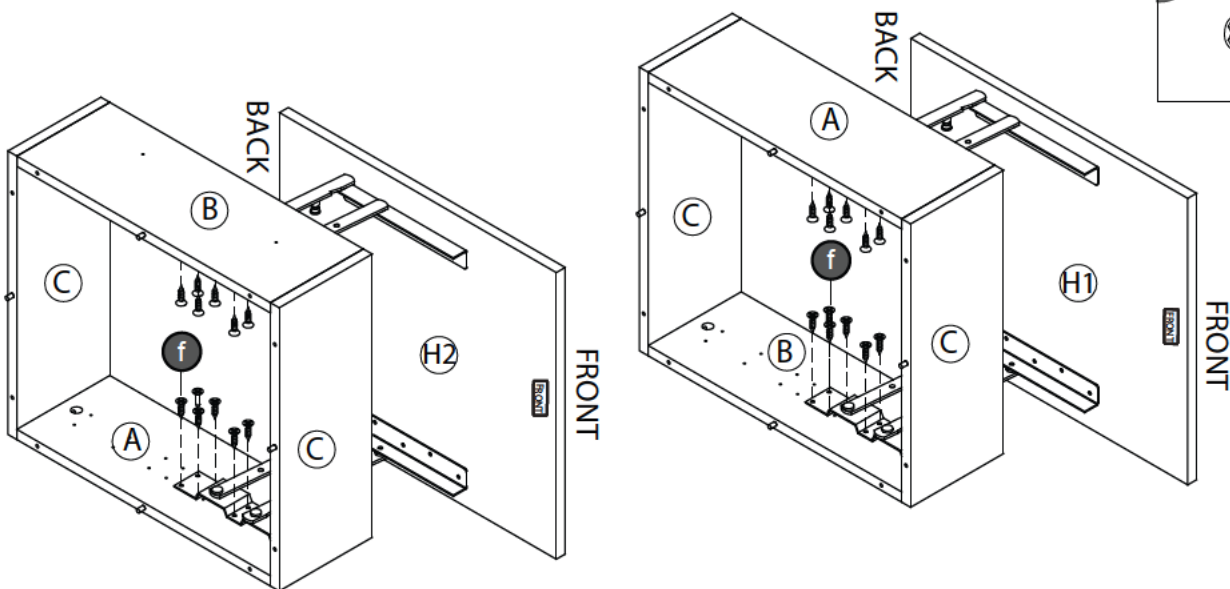

The Tops can be assembled either both open on the same sides or opposite sides.

Right opening

BACK FRONT

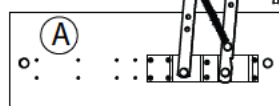

Left opening



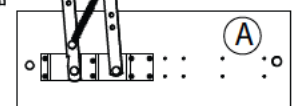

FRONT BACK

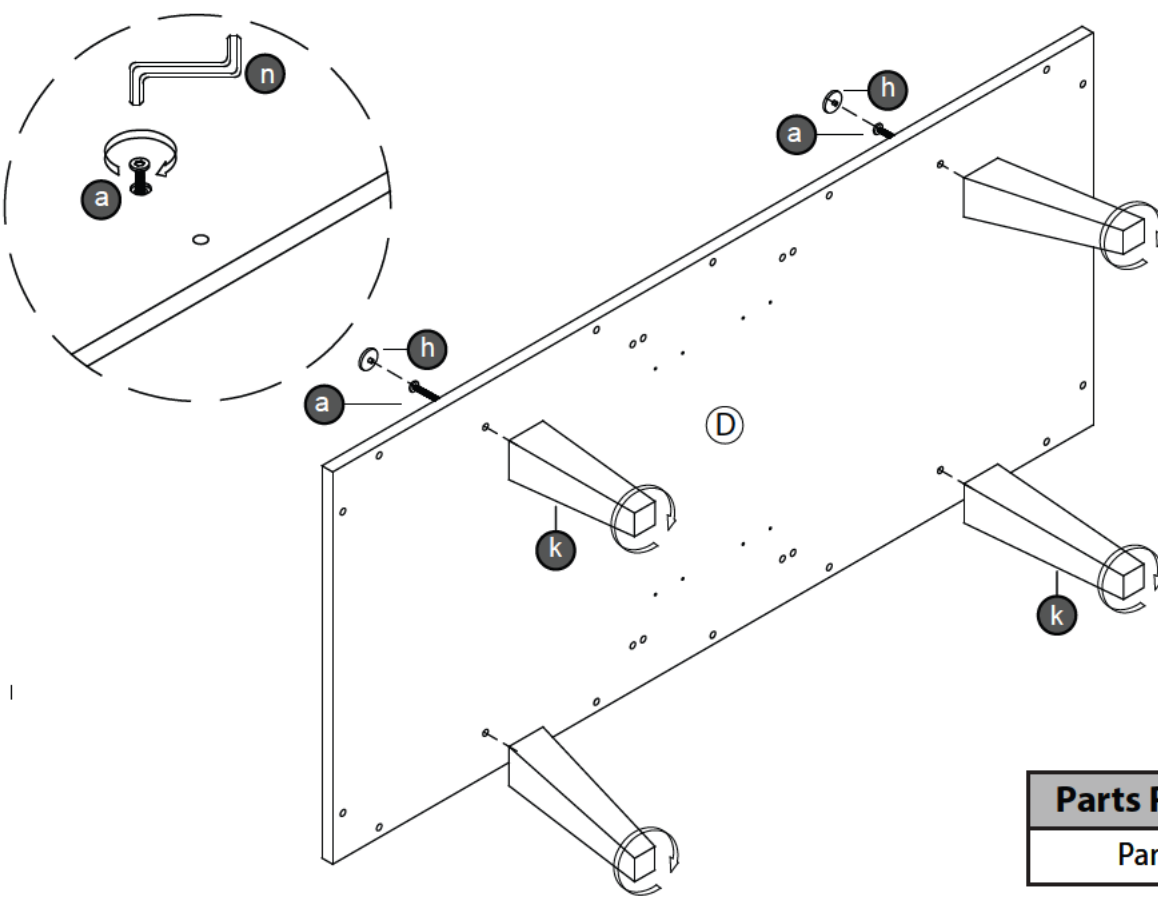

Parts Required	Qty
Panel (H1)	1
Panel (H2)	1

## STEP 8

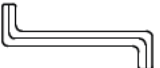



a		4 x
h		4 x
n		
k		4 x

Parts Required	Qty
Panel (D)	1

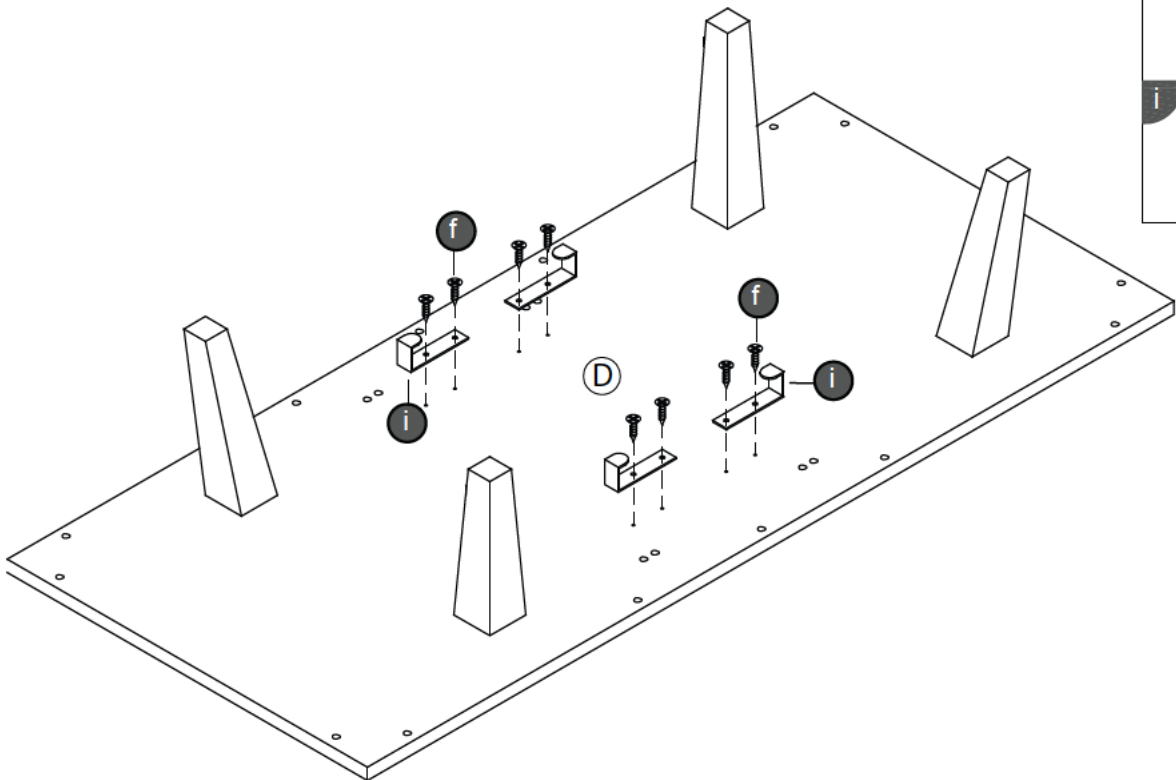
## STEP 9



f		8 x
i		4 x

## STEP 10

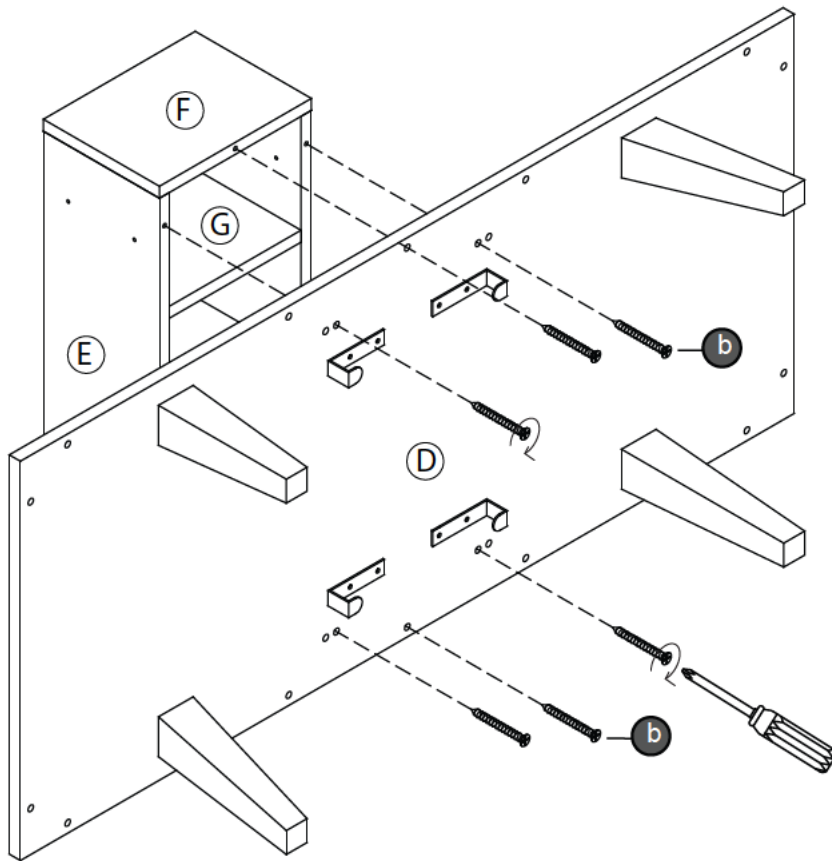

Parts Required	Qty
Panel (D)	1

## STEP 11

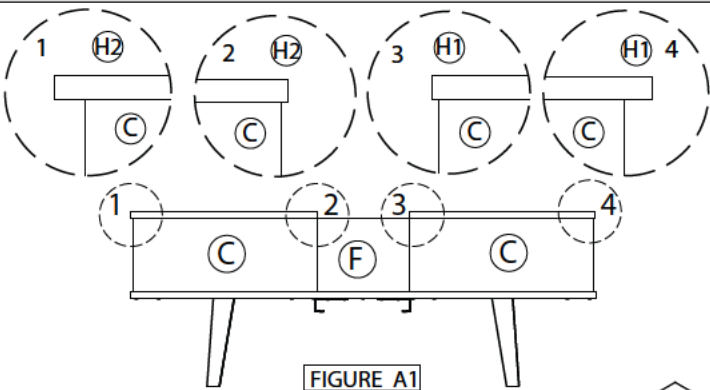

**\*IMPORTANT**  
**\*CHECK THAT TOP & STORAGE UNIT**  
**ARE CORRECTLY ALIGNED AS DETAILED**  
**IN FIGURE A1 BEFORE ASSEMBLY ON PANEL D.**

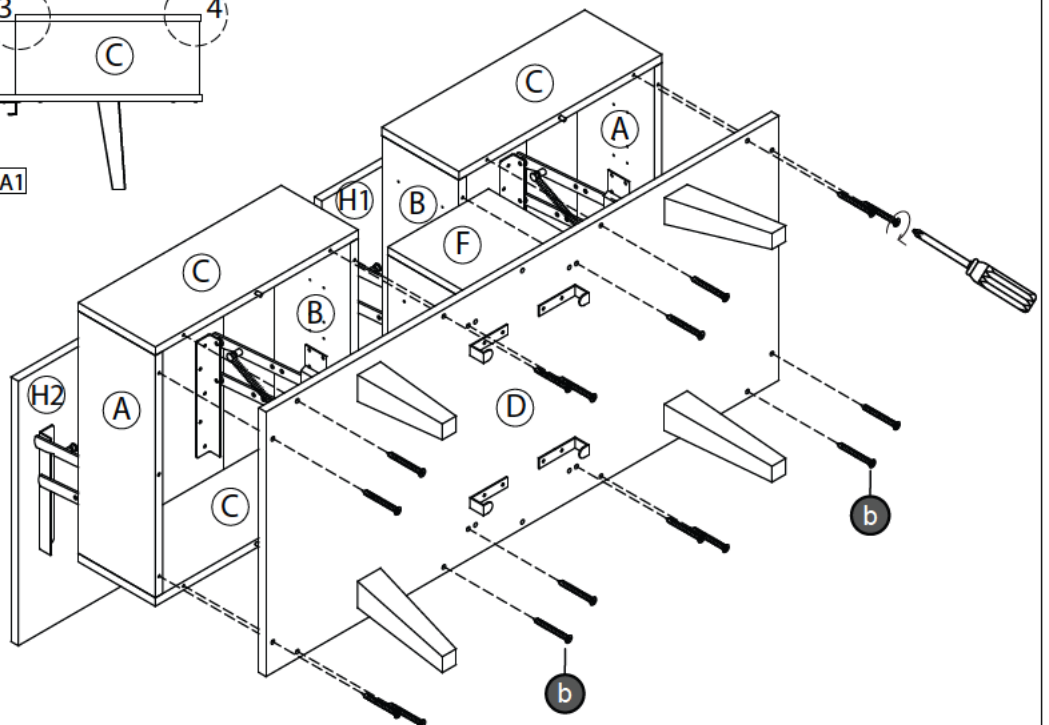
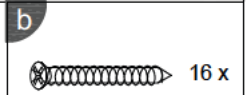

## STEP 12

e  4 x

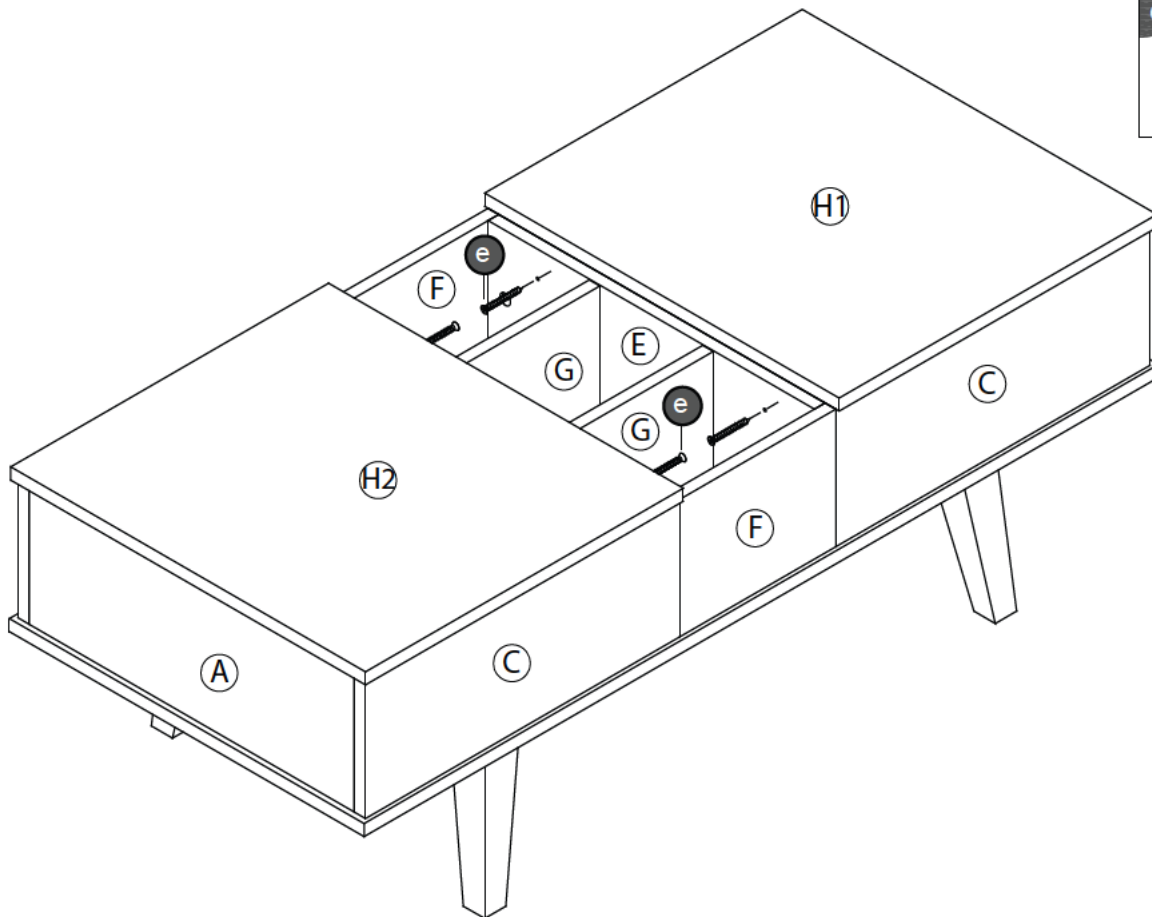

## STEP 13

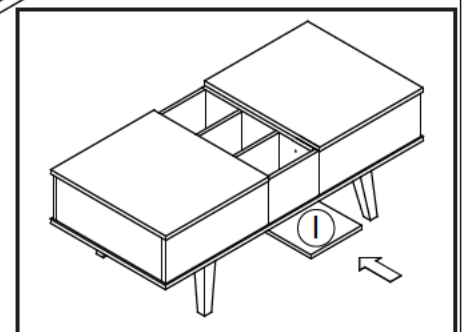
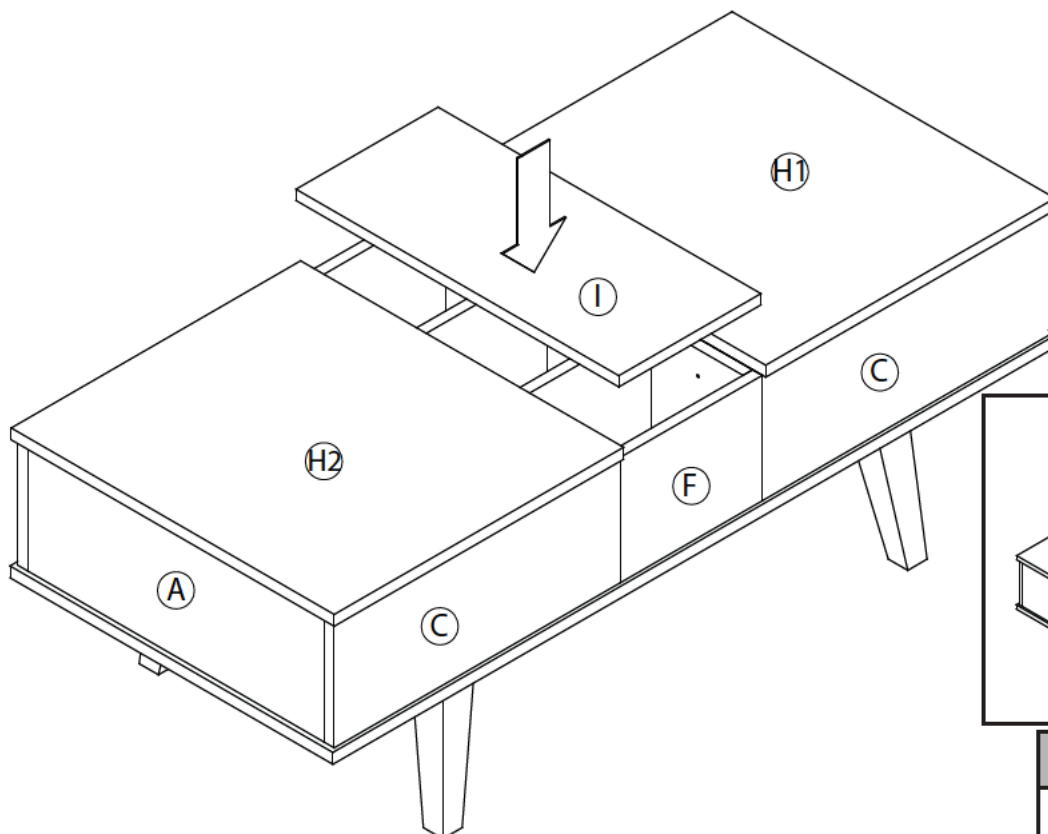

Parts Required	Qty
Panel (I)	1

## Complete Assembly

Your **DOUBLE LIFTING COFFEE TABLE** is now completely assembled

Periodically check to ensure that the components are in their proper position, free from damage. Also, make sure the connectors are tight and secure.

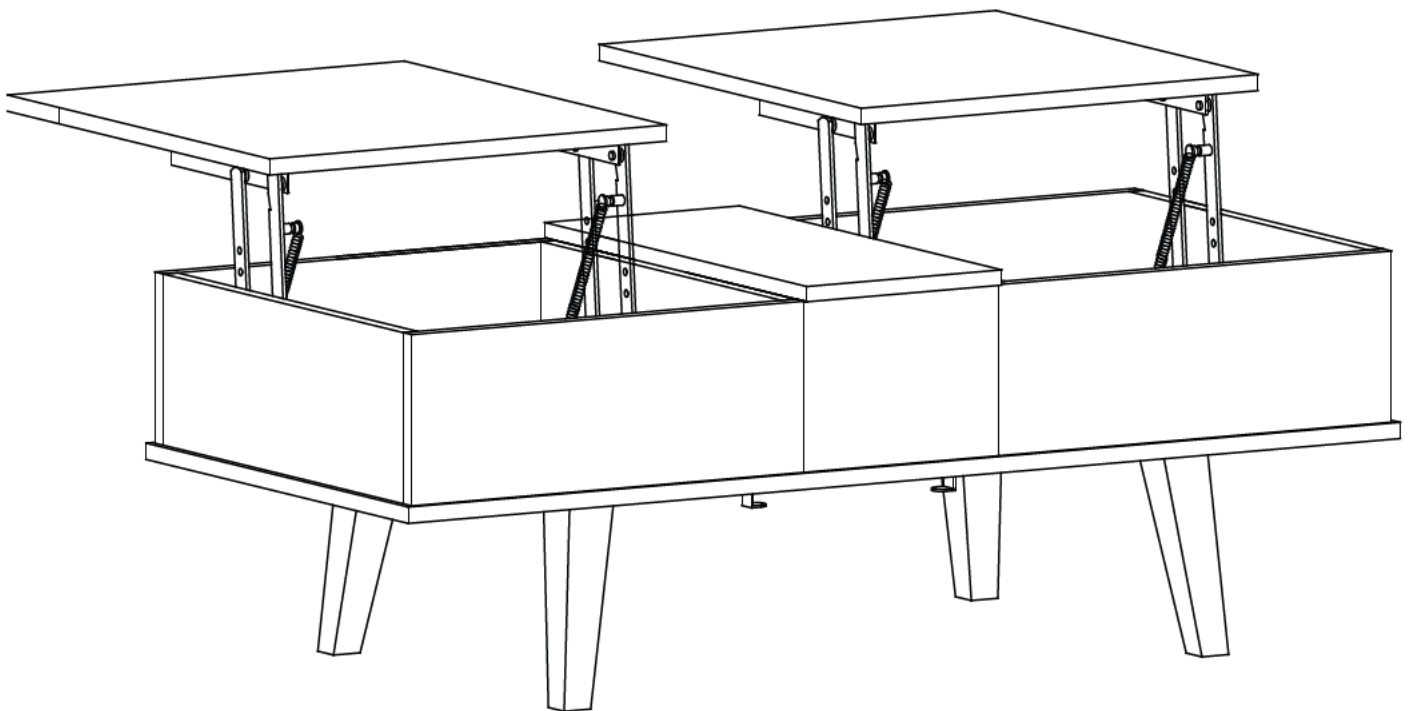

**Keep Instructions for future reference**

