



ASSEMBLY INSTRUCTION

Thank you for purchasing this quality product. Be sure to check all packing material carefully for small parts which may have come loose inside the carton during shipment. Separate, identify and count all parts and metal hardware. Compare with parts list to be sure all parts are present. If any part(s) are missing or damaged, please contact your local furniture dealer. For efficient and speedy service, please indicate the model number and code letter of part(s) needed.

*** Do not fully tighten screws until fully assembled ***

No.	COMPONENT LIST		Q'ty	No.	COMPONENT LIST		Q'ty
(A)		TABLE TOP	1pc	(B)		UPPER LEG	6pcs
(C)		STAND LEG	3pcs	(D)		SHELVES	2pcs

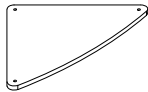
Step 1: Use your hand to rotate unclockwise stand leg (C) and upper leg (B).

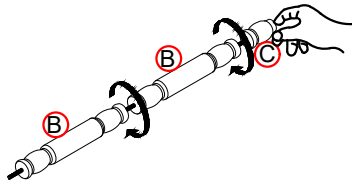

Step 2: Align and place Upper Leg (B) into Table Top (A) then use your hand to rotate clockwise fully tight.

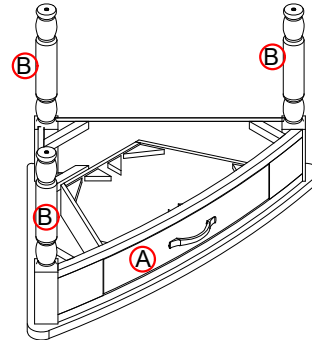

Step 3: Align and place shelf (D) into upper leg (B) then use your hand to rotate clockwise upper leg (B) fully tighten.

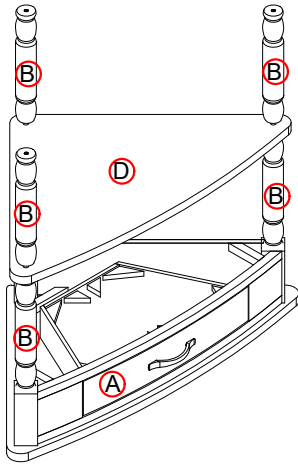

Step 4: Align and place shelf (D) into upper leg (B) and take stand leg (C) into upper leg (B) then use your hand to rotate clockwise stand leg (C) fully tighten.

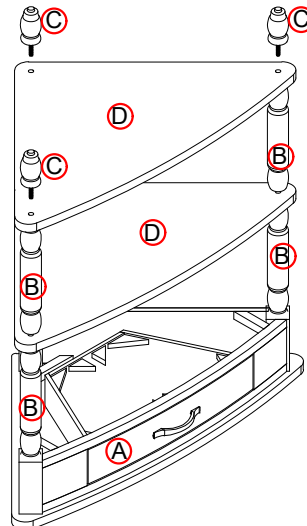

**FINISH .
THANK YOU !**