

Thank you for purchasing the **LEFT/RIGHT ARM CHAISE!**

Before you start, here are some helpful advice:

1. We suggest you spend a short time reading through this leaflet and then follow the simple step-by step instructions.
 2. Owing to the size and weight of the sofa, we recommend that it is assembled by two adults on a carpeted or padded area, in the room that it is intended for. Approximate time: 30 minutes.
 3. Please do not use any tools other than those provided or recommended in these instructions.
 4. Please do not throw away any of the packaging or instructions until you have checked all the components and hardware and the furniture is fully assembled.
 5. Assemble all components loosely until advised to tighten. Depending on use, it may be necessary to tighten the component from time to time, so please save the tools that have been provided.
 6. Please keep all pieces out of reach of children.
-

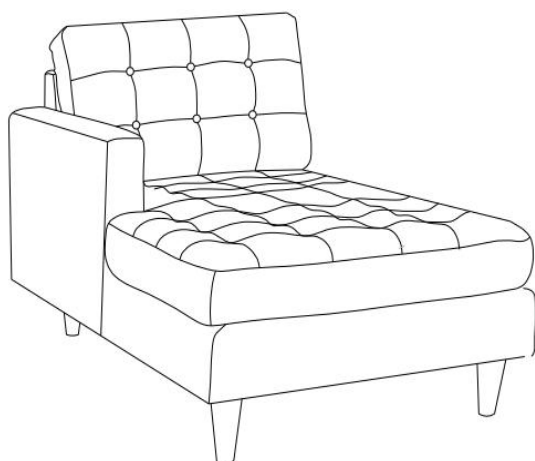
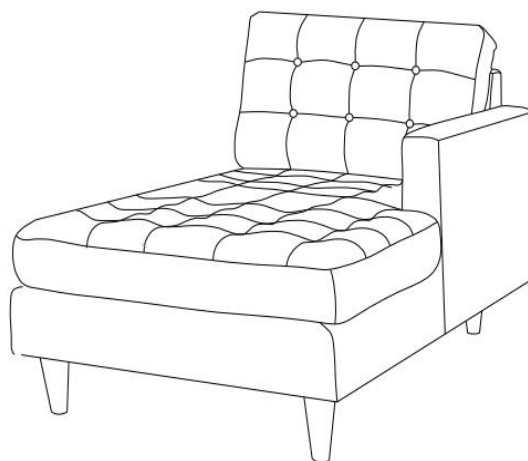

LEFT ARM CHAISE



RIGHT ARM CHAISE

Components:

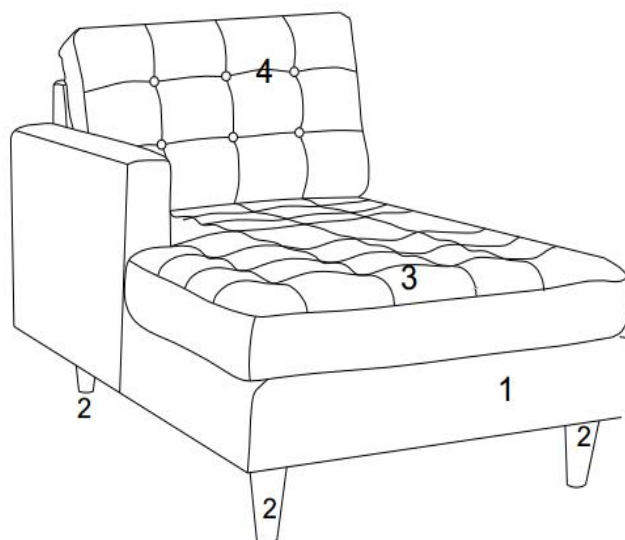

1. Chaise Frame x1

2. Leg x4

3. Chaise Seat Cushion x1

4. Chaise Back Cushion x1

LEFT/RIGHT ARM CHAISE

STEP 1:

Please put the **Chaise Frame (1)** without **Seat Cushion (3)**, **Back Cushion (4)** upside down on a carpeted or padded area by two adults to make fully visible the round metal plate on each corner and middle. Open the Zipper on the bottom of **Chaise Frame (1)** as shown, take out the packages of 4 pieces **Leg (2)**, then close the Zipper on the bottom of **Chaise Frame (1)**. Take off the Black Protection Cover on the 4 piece **Leg (2)**.

Insert 1 piece of **Leg (2)** into the hole on the round metal plate at the corners of the **Chaise (1)** as shown.

Use Hands to tighten the **Leg (2)** clockwise until secure. Repeat the same steps for the remaining **Legs (2)**.

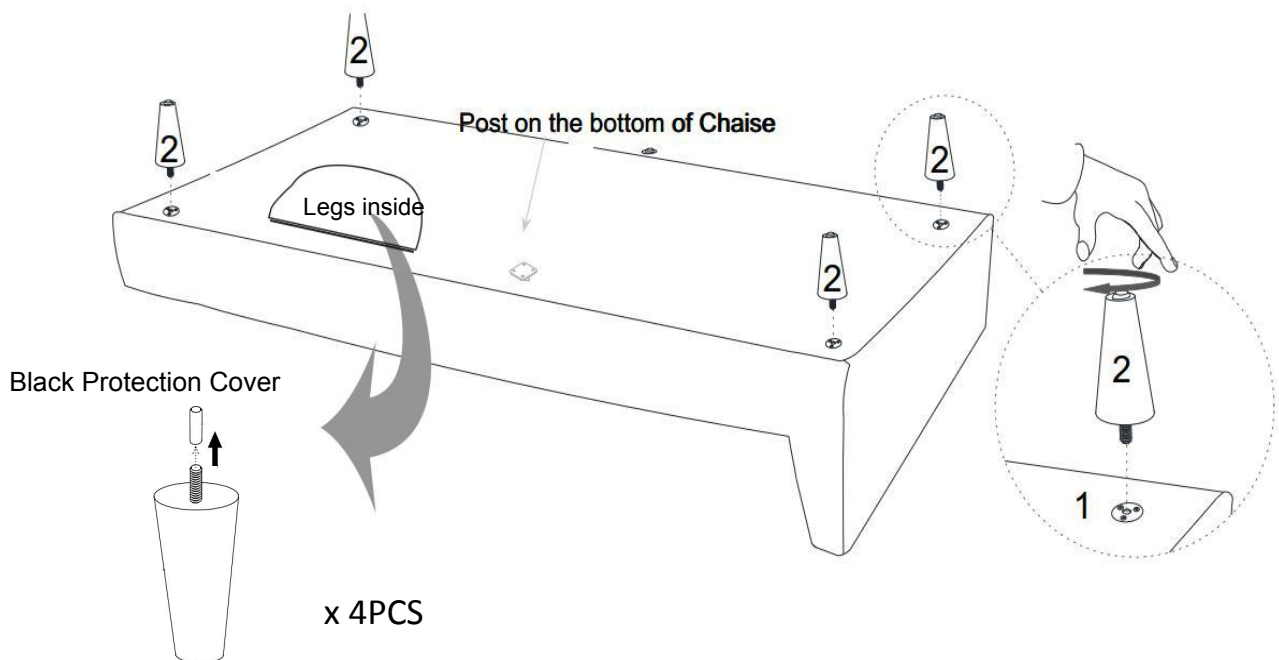

STEP 2:

Carefully turn over the **Chaise Frame (1)**. Put **Seat Cushion (3)**, **Back Cushion (3)** and **Side Cushion (4)** to the assembled **Chaise** as shown.

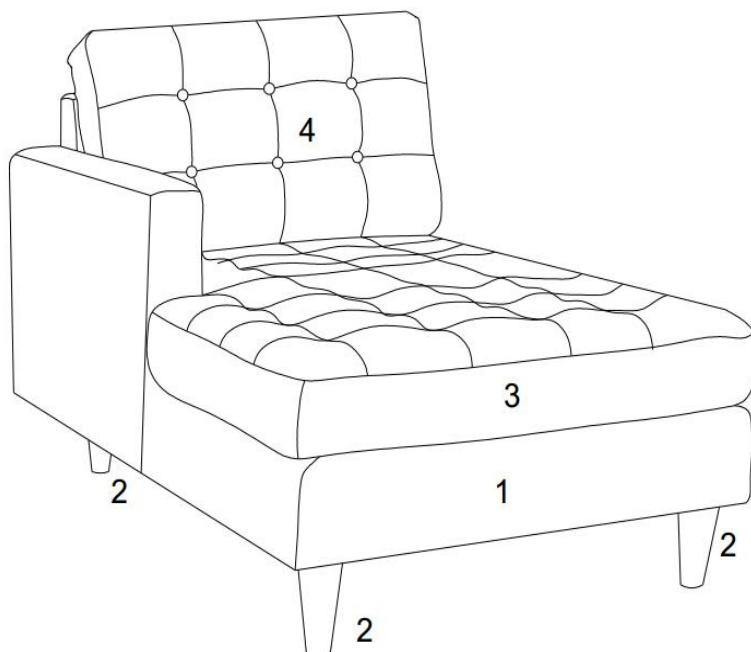

Assembly is complete. The Arm Chaise is ready to enjoy now!