

ASSEMBLY INSTRUCTION

INSTRUCTIONS DE MONTAGE

FULL BED LIT COMPLET

This set included 2 boxex if do not receive full 2 boxex. Please contact our customer service team

Cet ensemble comprenait 2 boxex si vous ne recevez pas 2 boxex complets. Veuillez contacter notre service client

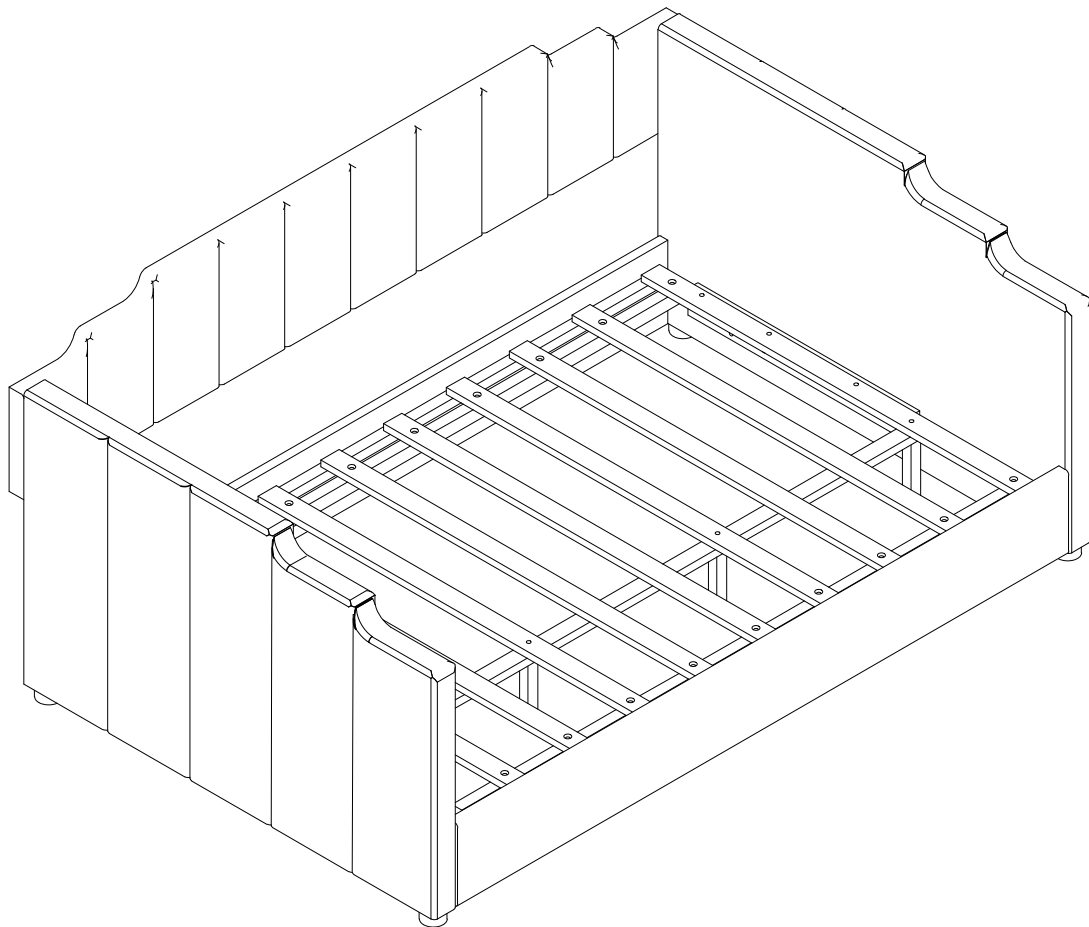



Part List

(Liste des pièces)



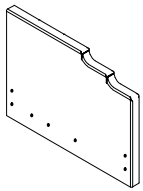
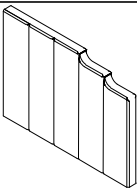

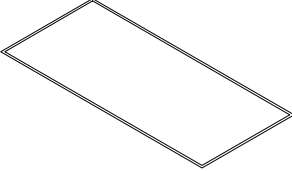
BOX 1/2

ENCADRÉ 1/2

<p>2</p>  <p>Side board Right -1pc Buffet latéral Droit -1 pièce</p>	<p>3</p>  <p>Side board Left -1pc Buffet latéral gauche - 1 pièce</p>	<p>Hardware (Matériel)</p> 
<p>L</p>  <p>Legs - 4pcs (JAMBE-4pcs)</p>	<p>17</p>  <p>bottom lining-1pc Fond doublure - 1 pièce</p>	

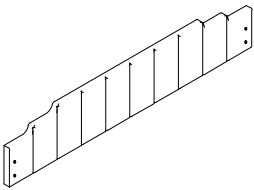
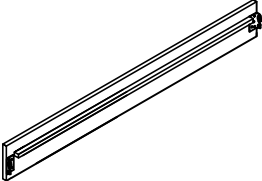
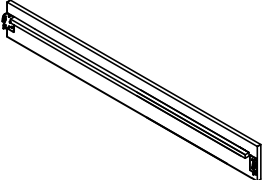
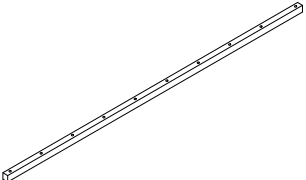
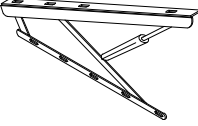
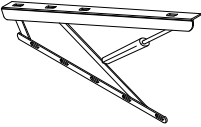
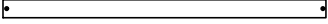
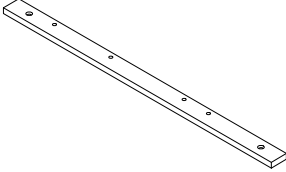
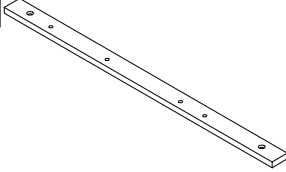
BOX 2/2

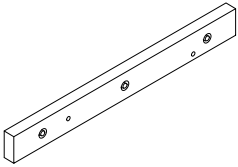
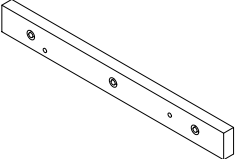
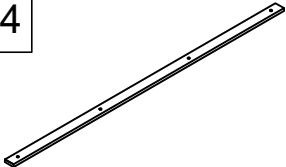









ENCADRÉ 2/2

<p>1</p>  <p>Head board -1pc Tête de lit - 1 pièce</p>	<p>4</p>  <p>Back Rails -1pc Dos de barrière - 1 pièce</p>	<p>5</p>  <p>Front Rails -1pc Rails avant - 1 pièce</p>	
<p>8</p>  <p>Bed support Slates -2pcs Lattes de support de lit - 2 pièces</p>	<p>13</p>  <p>Lift truck Left -1pc Chariot élévateur gauche -1 pièce</p>	<p>12</p>  <p>Lift truck Right -1pc Chariot élévateur droit - 1 pièce</p>	
<p>11</p>  <p>Slates-6pcs BARRES DE SUPPORT - 6 PCS</p>	<p>9</p>  <p>Slates Right-1pc SUPPORT CÔTÉ DROIT-1pc</p>	<p>10</p>  <p>Slates Left-1pc SUPPORT CÔTÉ GAUCHE</p>	<p>16</p>  <p>Slates-2pcs BARRES DE SUPPORT - 2 PCS</p>
<p>7</p>  <p>Bed side brace Left -1pc ATTELLE DE TÊTE DE LIT - 1PCS</p>	<p>6</p>  <p>Bed side brace Right-1pc ORTHÈSE DE CHEVET DROITE-1PCS</p>	<p>14</p>  <p>Bed support Slates-1pc SUPPORT DE LIT MOYEN-1PCS</p>	<p>15</p>  <p>Legs middle-4pcs JAMBES MILIEU-4PCS</p>

HARDWARE

Check that you've received
all hardware listed below.

Hardware List (Liste du matériel)

No.	OUTLOOK (PERSPECTIVES)	NOTE	QTY
(A)		Bolts 5/16"x30 mm (Boulons 5/16"x30 mm)	8
(B)		Bolts 5/16"x30 mm (Boulons 5/16"x30 mm)	22
(C)		Spring washer Ø5/16"x12 mm (Rondelle élastiquer Ø5/16"x12 mm)	22
(D)		Allen key 80x25x4 mm (clé Alle`n 80x25x4 mm)	1
(E)		Bolts 5/16"x45 mm (Boulons 5/16"x45 mm)	10
(K)		Bolts 5/16"x35 mm (Boulons 5/16"x35 mm)	4
(F)		Bolts 1/4"x30 mm (Boulons 1/4"x30 mm)	20
(G)		Bolts 1/4"x 20 mm (Boulons 1/4"x 20 mm)	10
(H)		Plain washer Ø1/4"x19x1.5 mm (Rondelle plate Ø1/4"x19x1.5 mm)	30
(I)		Spring washer Ø1/4"x10 mm (Rondelle élastiquer Ø1/4"x10 mm)	30

STEP 1 (ÉTAPE 1)

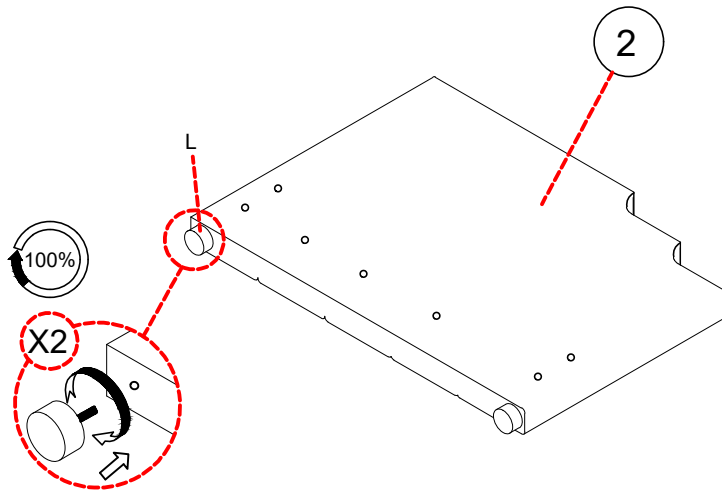
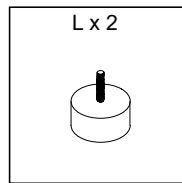

STEP 2 (ÉTAPE 2)

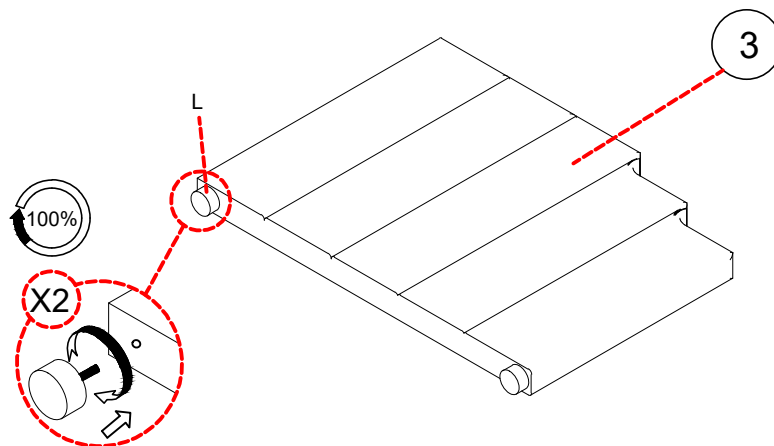
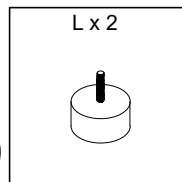

STEP 3 (ÉTAPE 3)

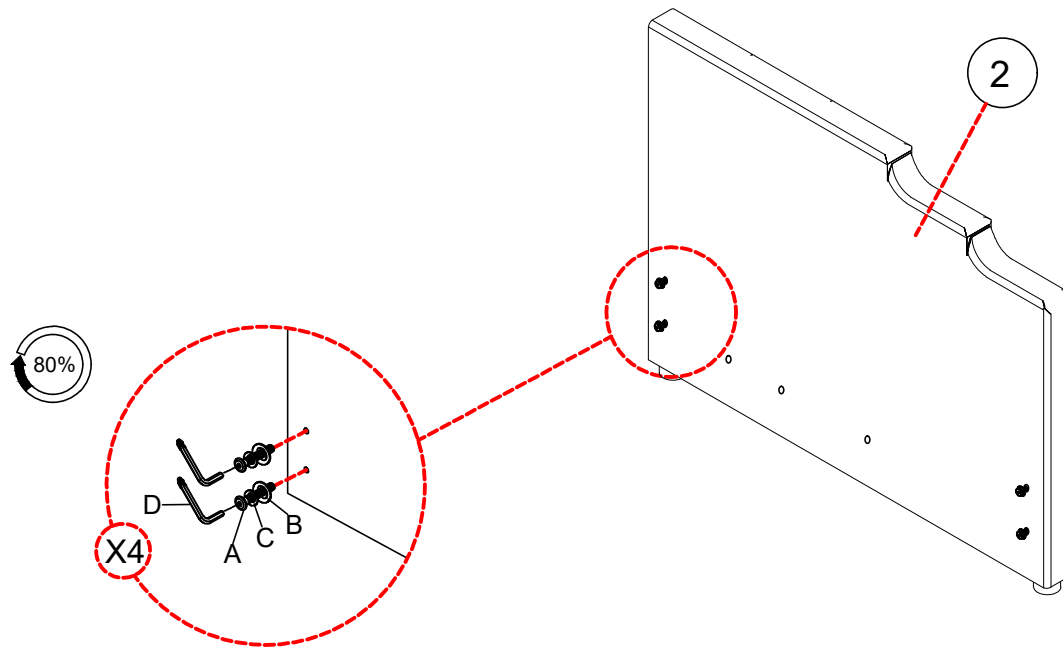
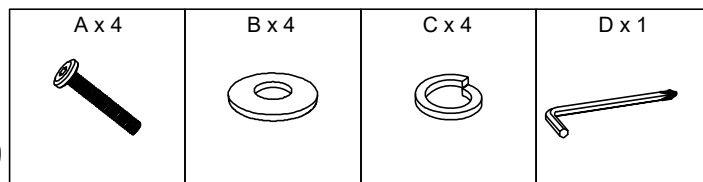

STEP 4 (ÉTAPE 4)

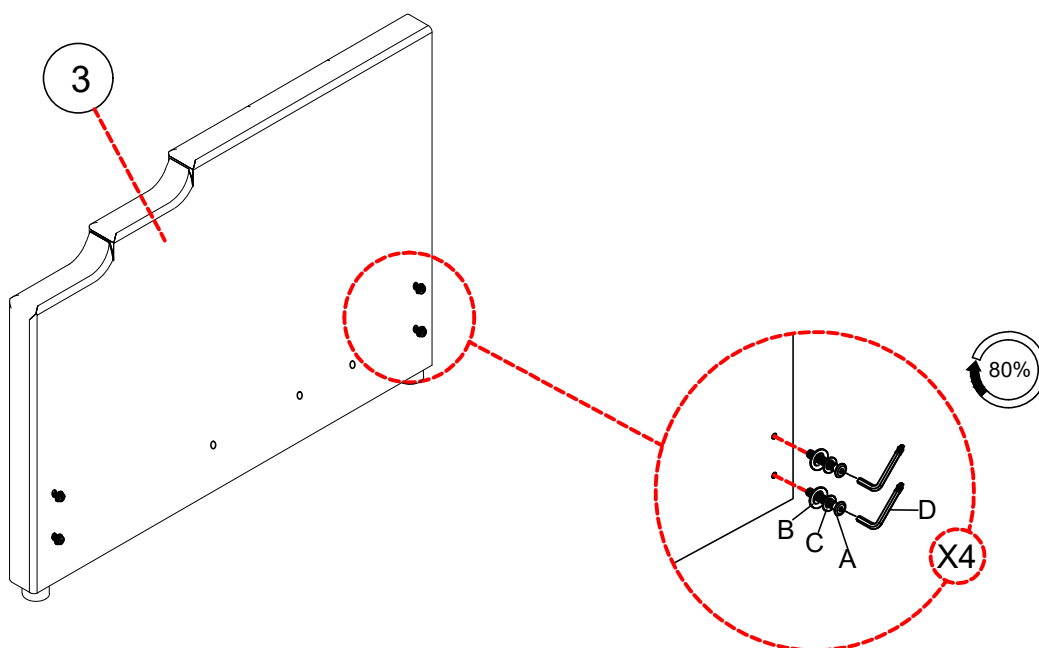
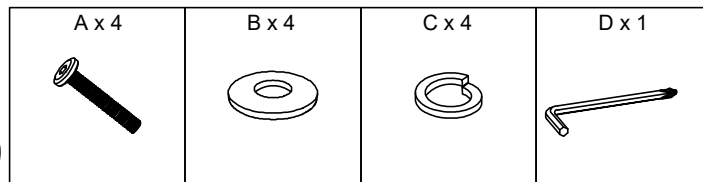

STEP 5 (ÉTAPE 5)

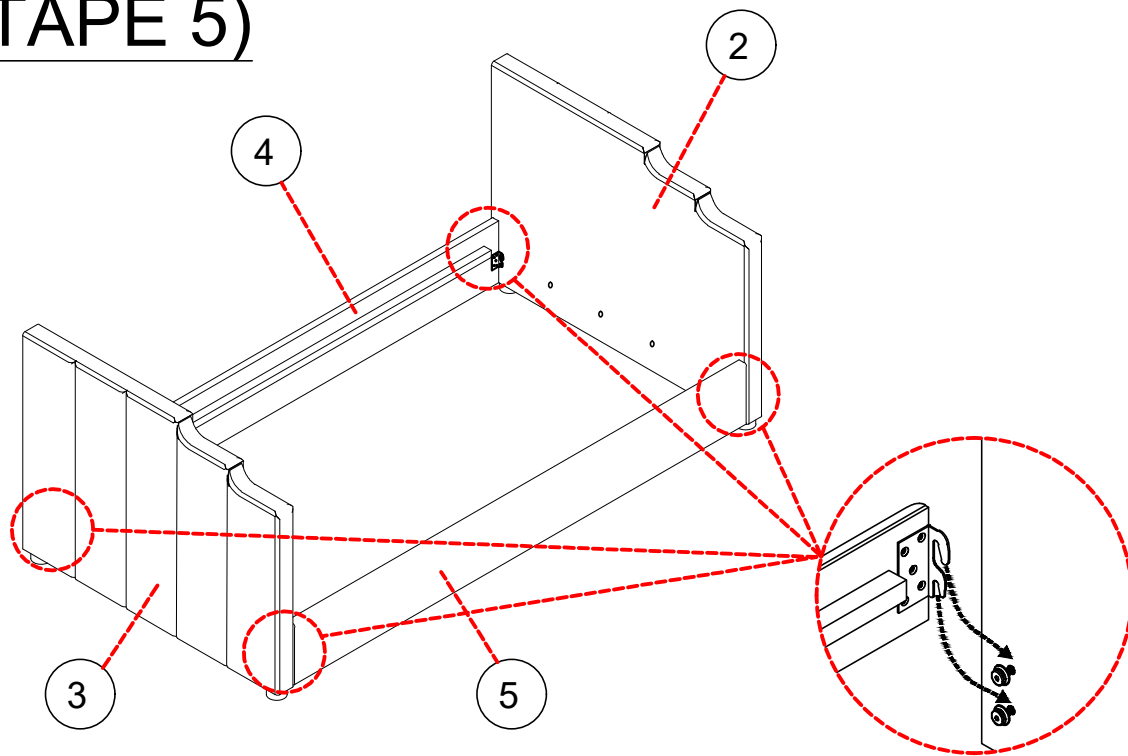

STEP 6 (ÉTAPE 6)

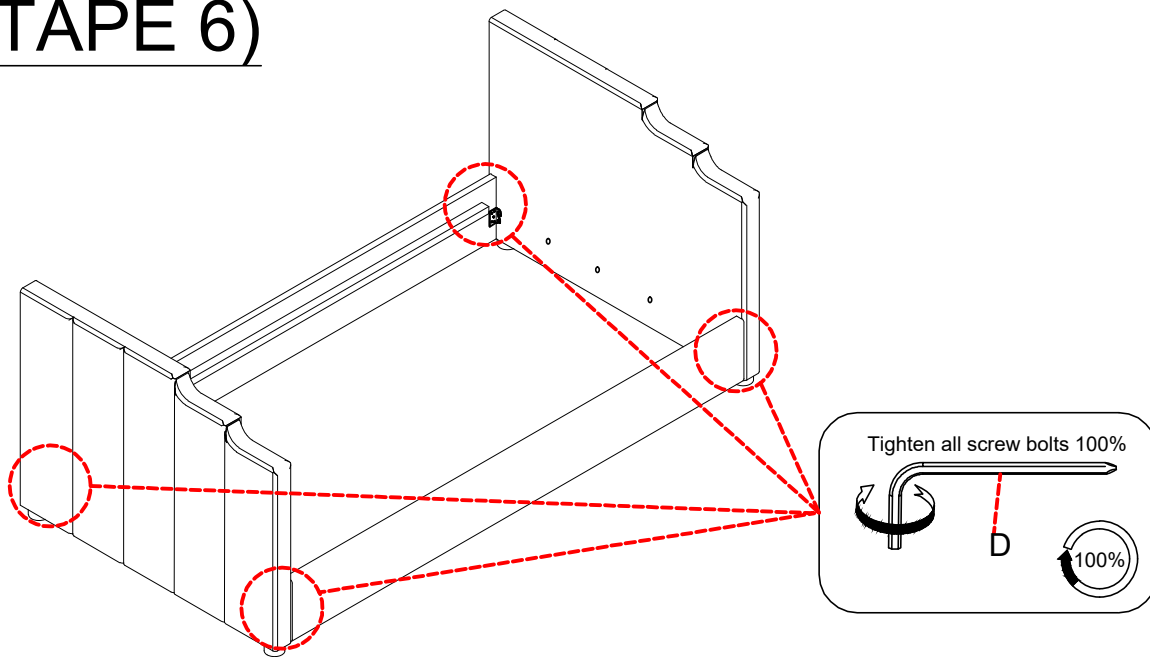

STEP 7 (ÉTAPE 7)

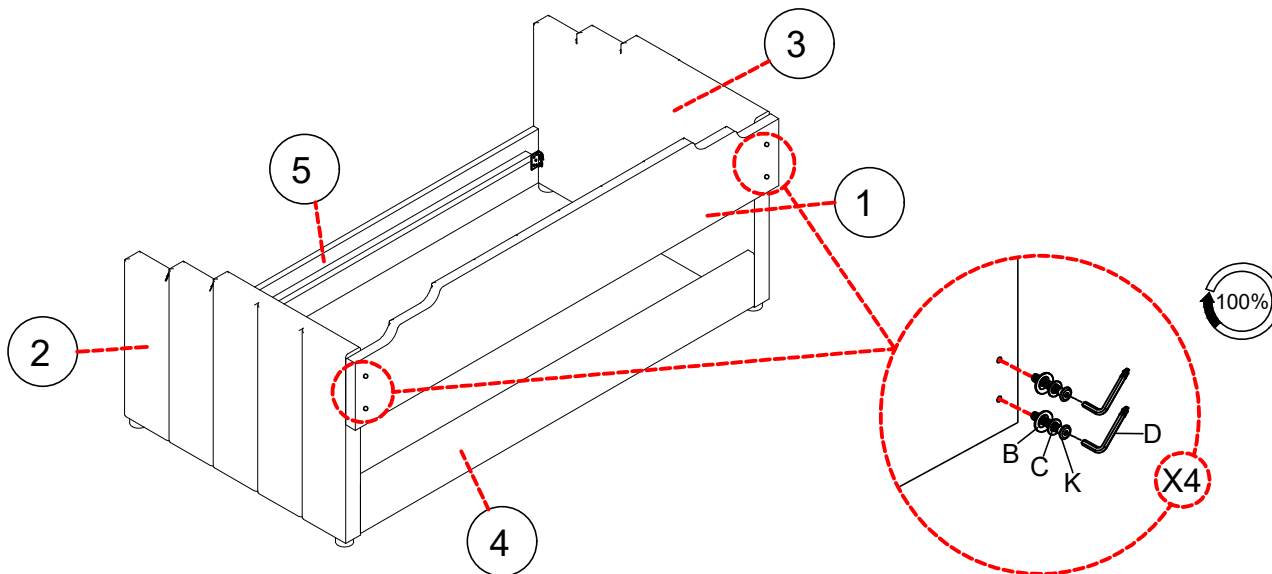
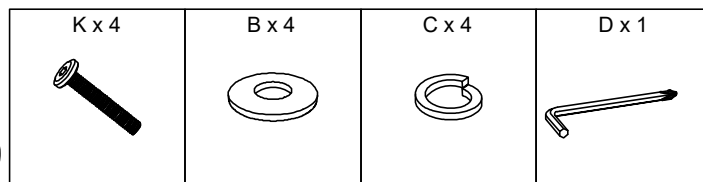

STEP 8 (ÉTAPE 8)

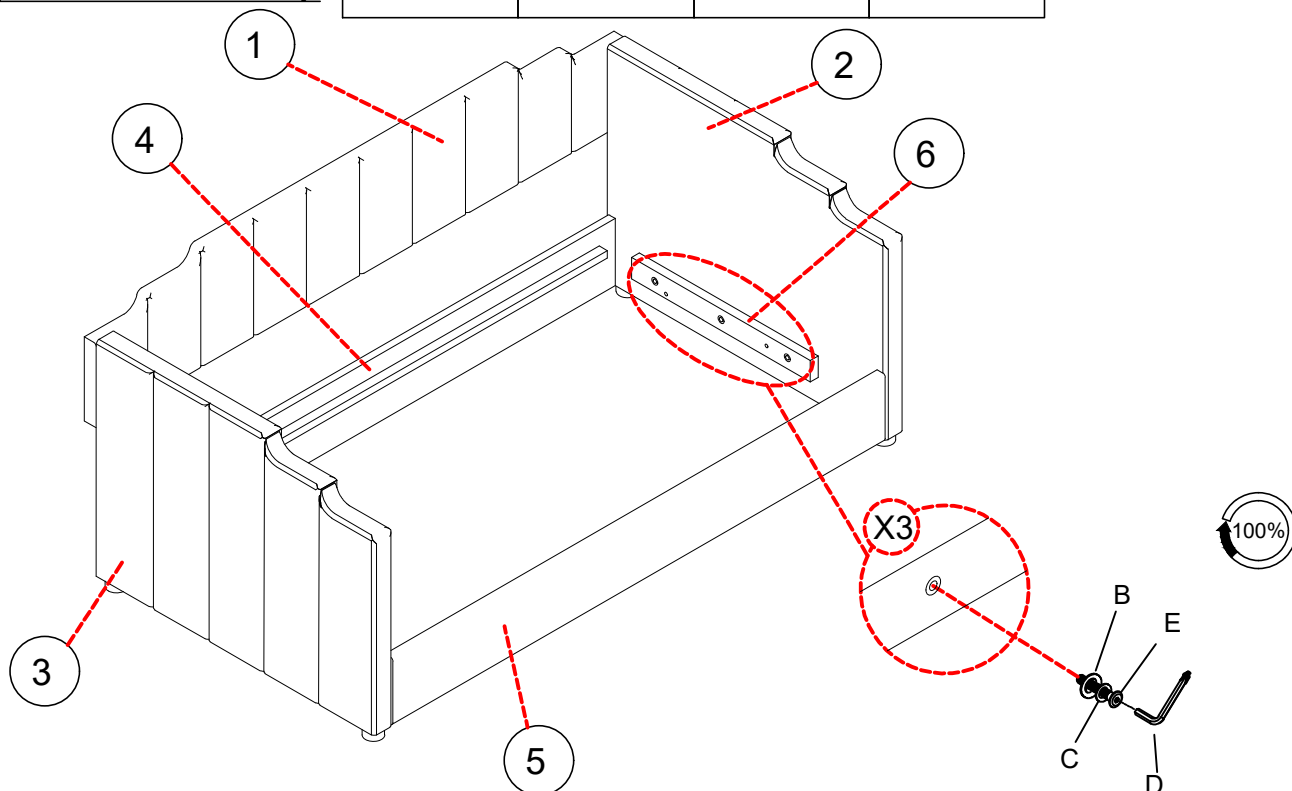
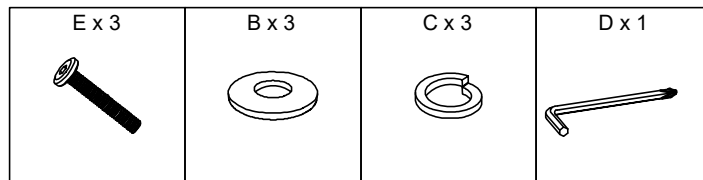

STEP 9 (ÉTAPE 9)

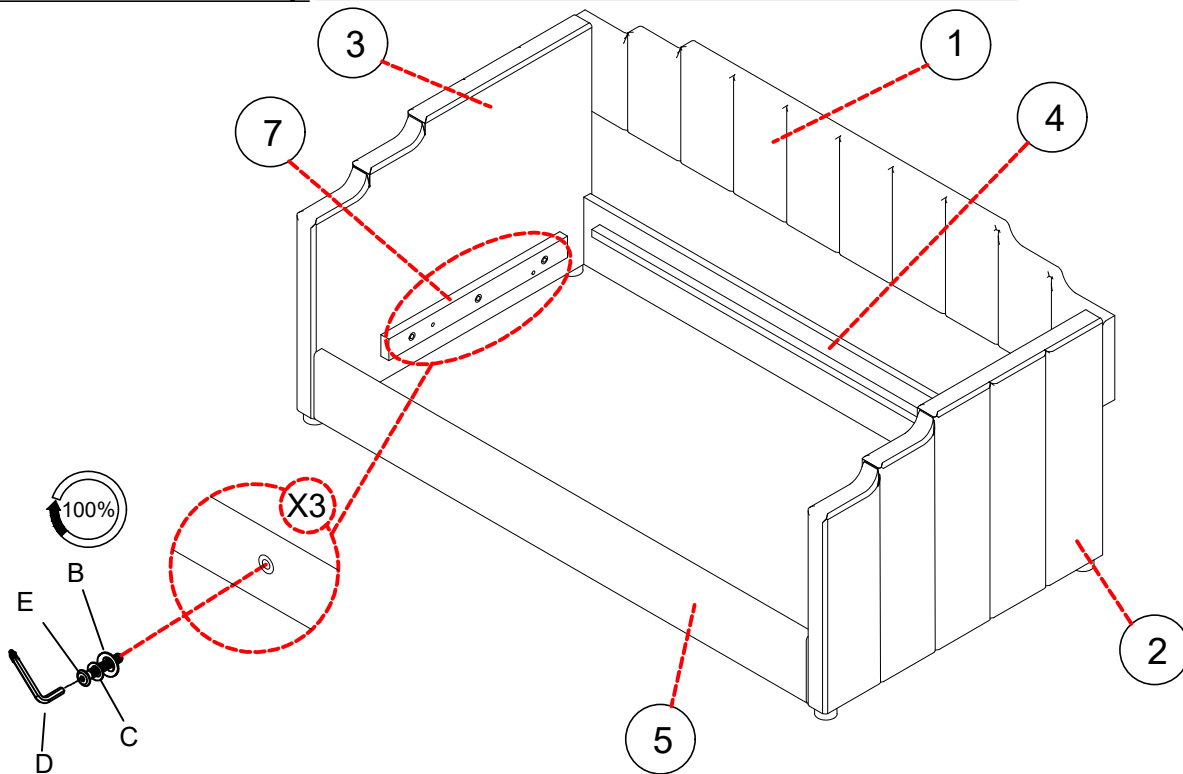
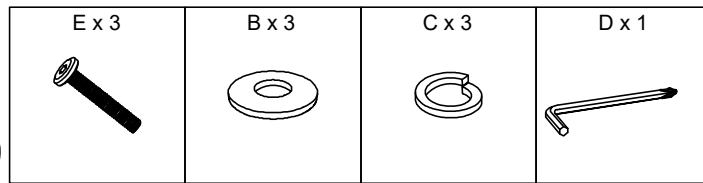

STEP 10 (ÉTAPE 10)

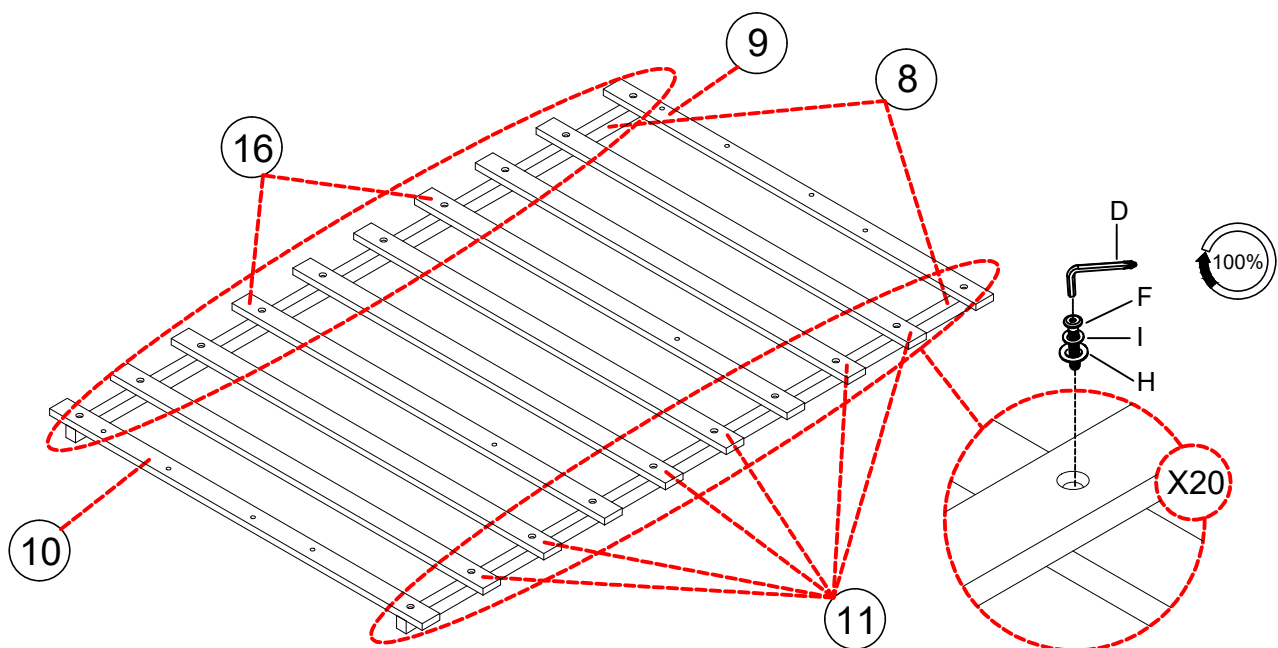
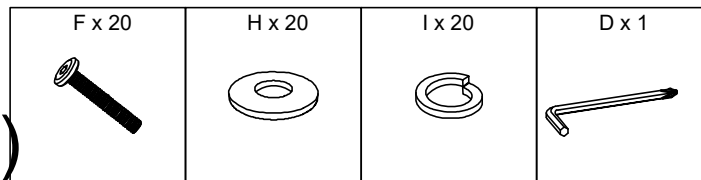

STEP 11 (ÉTAPE 11)

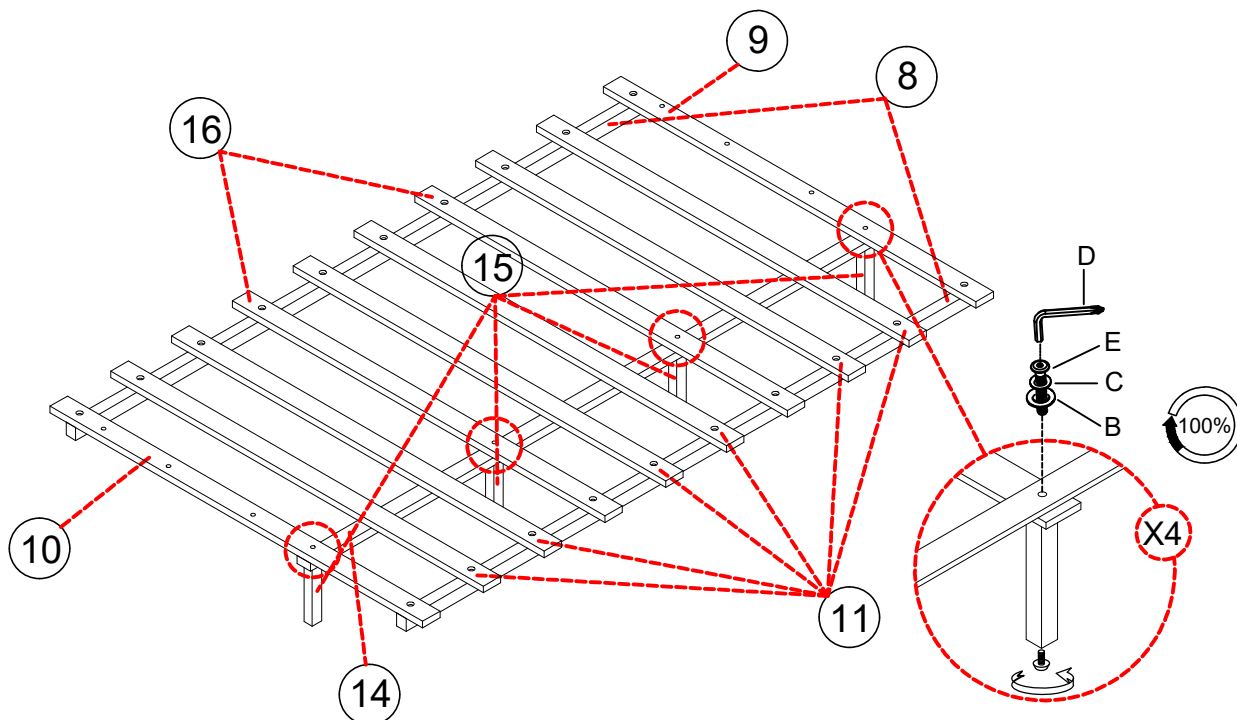
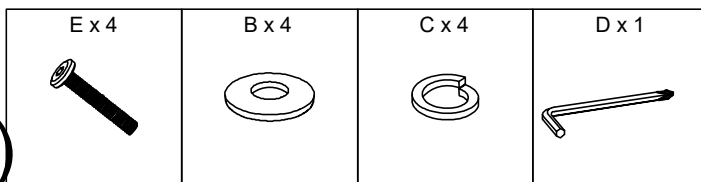

STEP 12 (ÉTAPE 12)

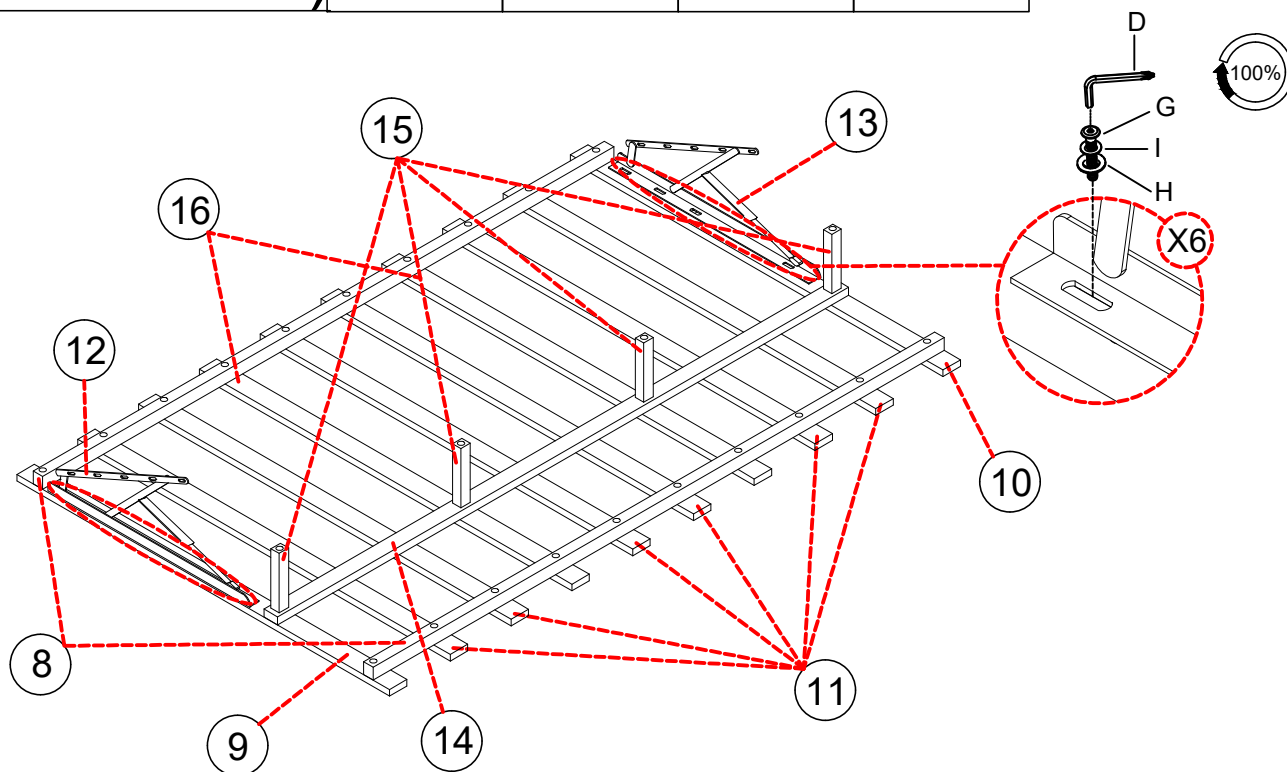
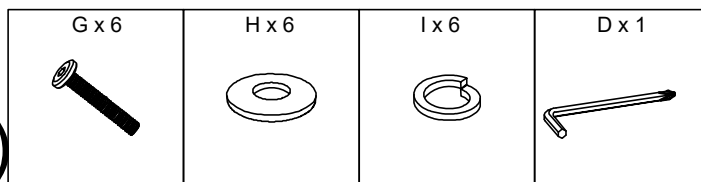

STEP 13 (ÉTAPE 13)

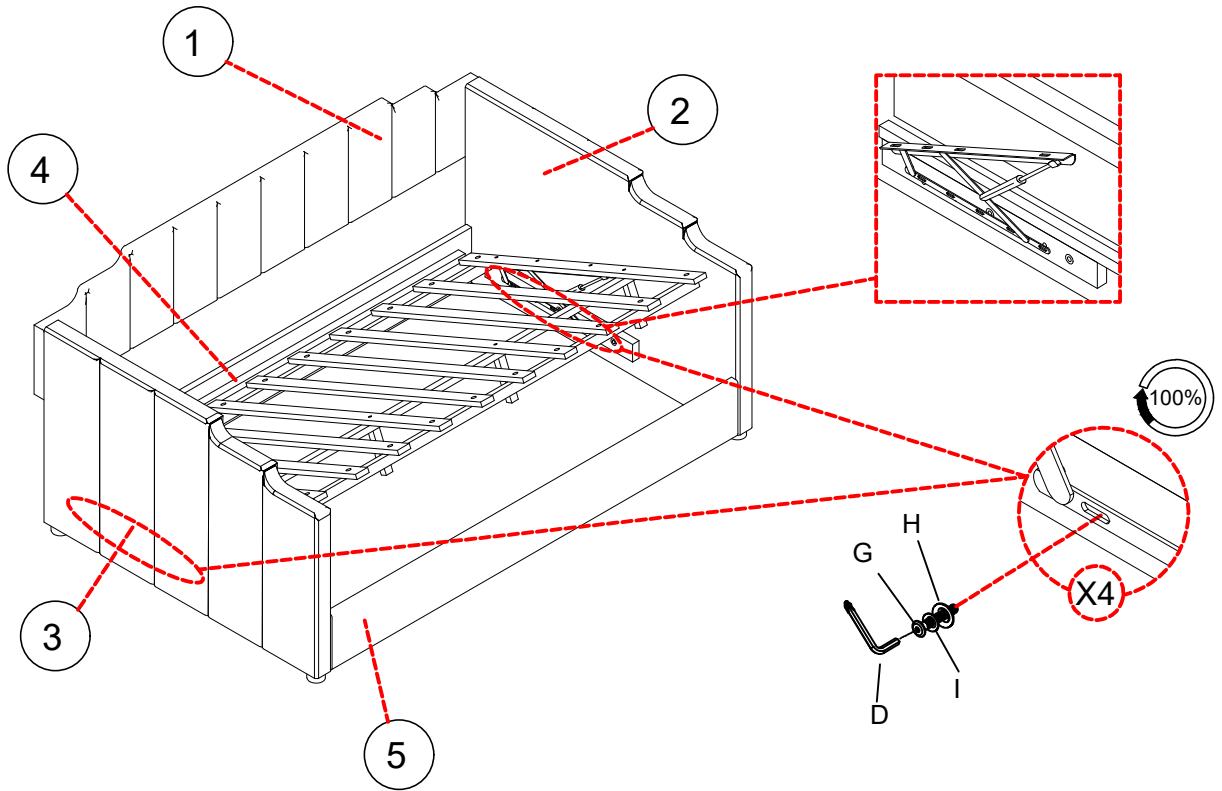
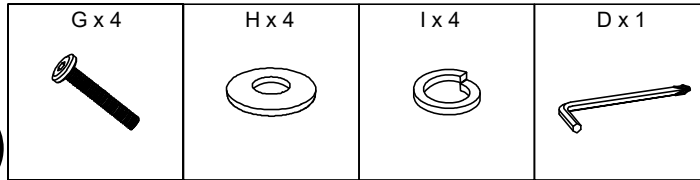

STEP 14 (ÉTAPE 14)

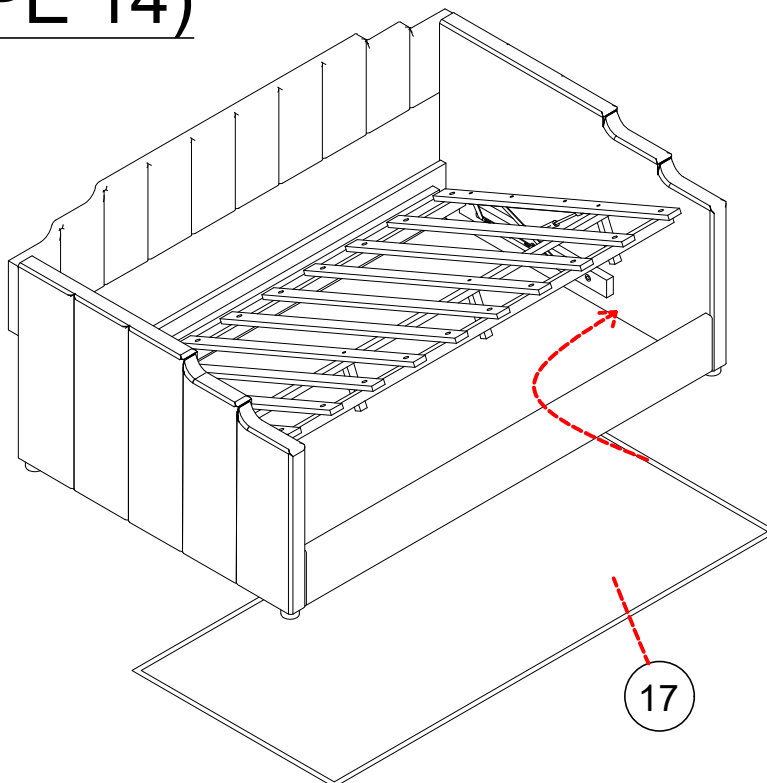

COMPLETE

(COMPLET)

