

TIGER APEX BUILDINGS

GENERAL ASSEMBLY INSTRUCTIONS

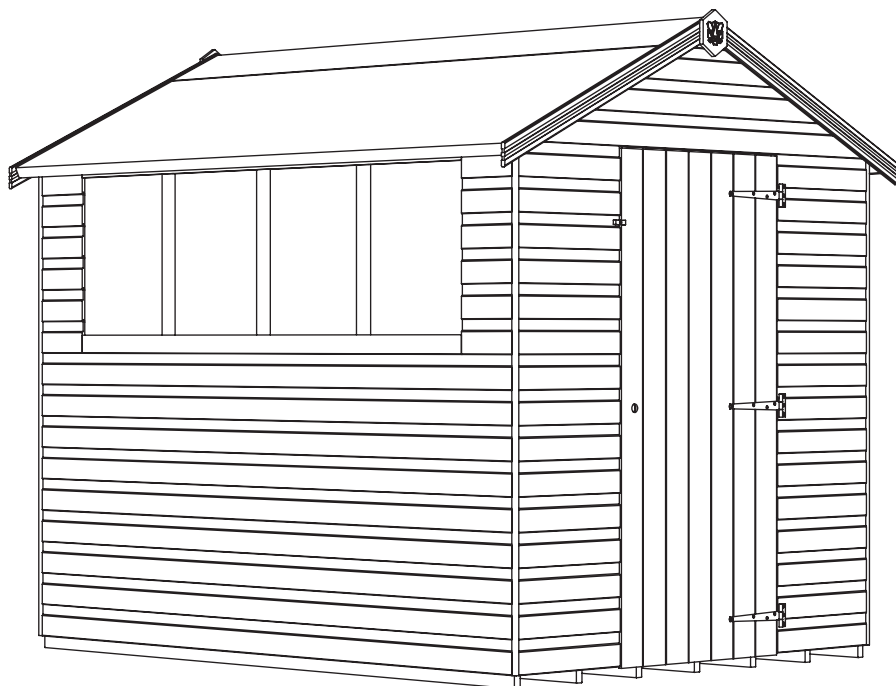

BEFORE YOU GET STARTED

PLEASE READ INSTRUCTIONS CAREFULLY

- Check the pack and make sure you have all the parts listed.
- When you are ready to start, make sure you have the right tools at hand (not supplied).
- Ensure there is plenty of space and a clean dry area for assembly.

TIMBER

As with all natural materials, timber can be affected during various weather conditions. For the duration of heavy or extended periods of rain, swelling of the wooden panels may occur. Warping of the wood may also occur during excessive dry spells due to an interior moisture loss. Unfortunately, these processes cannot be avoided but can be mitigated. It is suggested that the outdoor building is sprayed with water during extended periods of warm sunshine and sheltered as much as possible during rain or snow.



SUMMER
CONTRACTION



WINTER
EXPANSION



WOOD WARPING
MAY OCCUR

To validate your guarantee and ensure longevity of the product, it is ESSENTIAL that your building is treated with an appropriate high-quality oil or solvent based preservative AFTER assembly, both internally and externally, and annually thereafter. All glazing units must be sealed (internally and externally) with silicone or other watertight sealant.

BUILDING A BASE

Care must be taken to ensure the product is placed on a suitable base. When thinking about where the building and base is going to be constructed, ensure that there will be access to all sides for maintenance work and annual treatment.

Ensure the base is firm and level and is built on firm ground, to prevent distortion.

The constructed base must be at least the size of product as referenced in supplied construct diagram. It is also recommended that the floor be at least 25mm above the surrounding ground level to avoid flooding.

TYPES OF BASE

- Durable plastic grid*
- Concrete 75mm laid on top of 75mm hard-core.
- Slabs laid on 50mm of sharp sand.
- Timber Base - Self constructed/Buy pre-made.



PLASTIC BASE



CONCRETE BASE

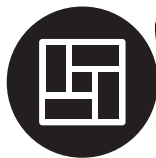

SLAB BASE



TIMBER BASE



BROKEN SLABS



BARE SOIL



LOOSE GRAVEL

**We recommend a Fastfit EcoBase for your building. It is durable, lightweight, flexible and easy to put in place. Please see [tigersheds.com](https://www.tigersheds.com) for details.*

CAUTION:

All buildings should be erected by two competent adults.



CAUTION:

It is advisable to wear gloves during building installation.



The mark of responsible forestry
FSC® C125286



MADE IN THE UK SINCE 1913.

We have been making our high quality, great value garden buildings here in Britain for decades.

***TigerSkin® Water Based Treatment:**

The unique formula of our **TigerSkin®** pre-treatment provides a reassuring layer of protection for your shed or summer house. Each panel is carefully dipped and dried to provide maximum coverage and ensure that your building will have protection from the moment it arrives and is assembled. A water repellent formula which is harmless to plants, not only does it help to shield the timber, it also gives it a warm tone that looks great on your property. Once erected, your building should be treated annually, both internally and externally with an appropriate high-quality oil or solvent based preservative.

Whilst all products manufactured are made to the highest standards of safety, we cannot accept responsibility for your safety whilst erecting or using this product.

GO WITH THE PRO!

We understand how busy life can be. Our Pro-Installation service can take the stress and strain out of assembling your quality Tiger building for you. We recommend using professional and dedicated installers to erect your building. With their knowledge and experience, they will ensure that your cabin is put properly in place ready for you to enjoy your space for years to come.

If you have not booked our Pro-Installation service and would like to arrange an installation, please contact our friendly customer support team on **0113 205 4189** (Mon – Fri 9am-5pm) or email **sales@tigersheds.com**.

- The pro-install team will contact you to arrange a suitable time and date for the fitting.
- Sit back, relax and let our professional home installation service do all the hard work for you!
- Please view the Pro Installation page on tigersheds.com for full terms & conditions and to see if your postcode area is covered by our Pro-Install teams.

TIGER APEX BUILDING RANGE

GUIDANCE:

This guide provides assembly information for the Tiger Apex Building range. Images are for reference only and may vary from the product you have been supplied. If you have any issues, please contact your supplier.

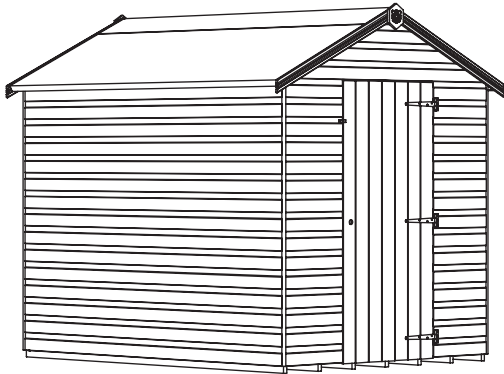

TIGER SHIPLAP APEX WINDOWLESS SHED

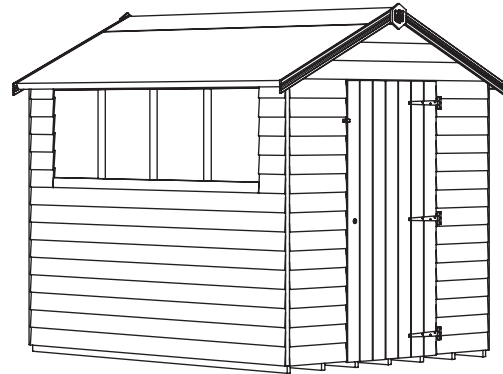

TIGER APEX SHED

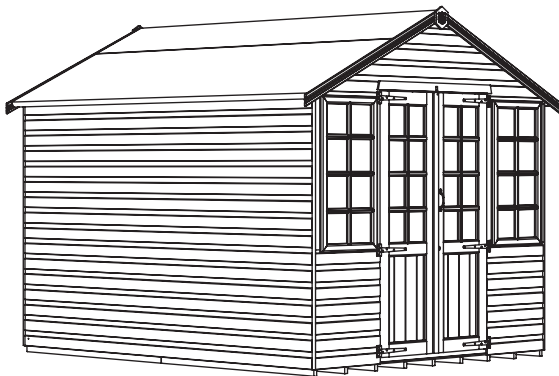

TIGER SUMMERHOUSE

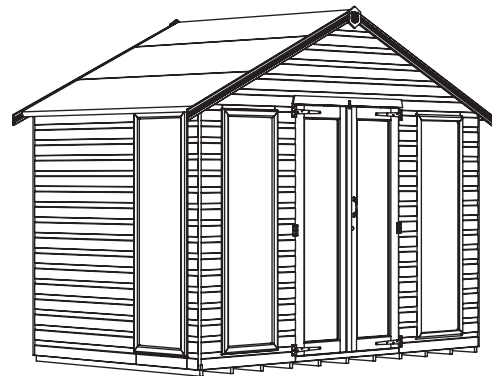

TIGER CONTEMPORARY SUMMERHOUSE

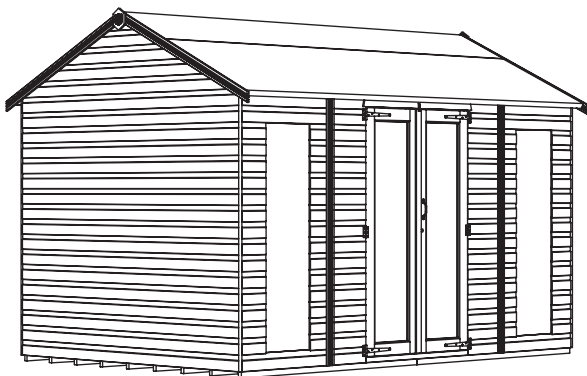

TIGER RETREAT CONTEMPORARY SUMMERHOUSE

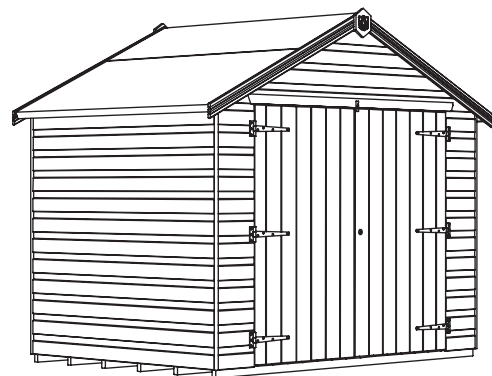

TIGER BIKE SHED



TIGER HEAVYWEIGHT WORKSHOP

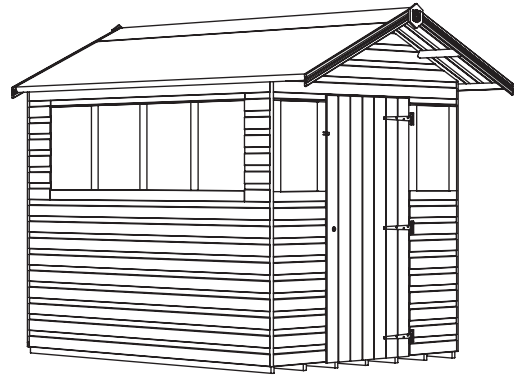

TIGER SUMMER SHED

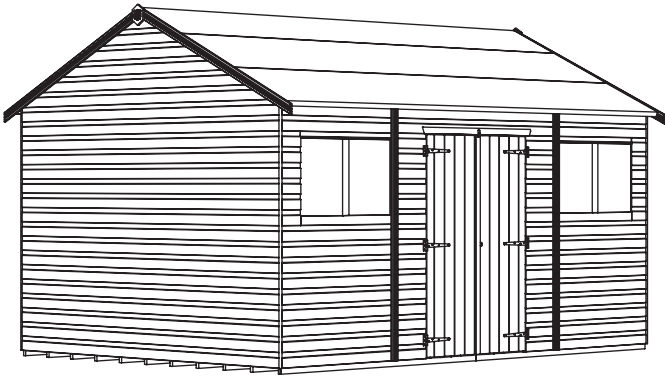

TIGER WORKMAN APEX



TIGER SUMMER BREEZE SUMMERHOUSE

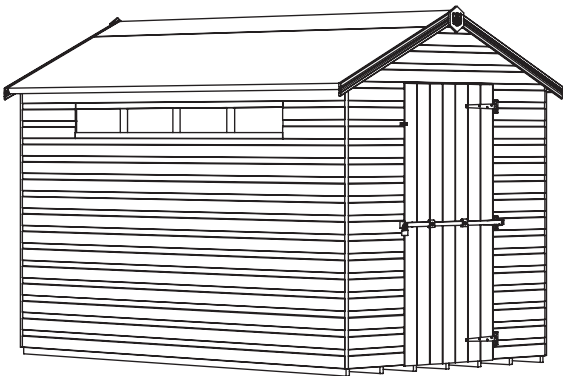

TIGER SECURITY APEX SHED

BEFORE YOU GET STARTED - PRE ASSEMBLY

TOOLS REQUIRED:

We recommend using the following tools (not supplied):



HAMMER



RUBBER MALLET



LADDER



TAPE MEASURE



SHARP KNIFE



SPIRIT LEVEL



SCREWDRIVER +



WOOD SAW



SPANNER

FIXING KIT GUIDES:

FX02 - NAIL KITS SMALL

For Shed Products Up To 6ft Sides:

- CN13** Clout Nails (13mm Galvanised - QTY 200)
- PP25** Panel Pins (25mm - QTY 100)
- N40** Nail (40mm Galvanised - QTY 50)
- NG5** Nail (65mm Bright - QTY 30)
- CB80** Coach Bolts (80mm - QTY 8)

FX04 - NAIL KITS LARGE

For Shed Products With 10ft to 13ft Sides:

- CN13** Clout Nails (13mm Galvanised - QTY 300)
- PP25** Panel Pins (25mm - QTY 140)
- N40** Nail (40mm Galvanised - QTY 85)
- NG5** Nail (65mm Bright - QTY 60)
- CB80** Coach Bolts (80mm - QTY 8)

FX03 - NAIL KITS MEDIUM

For Shed Products With 7ft to 9ft Sides:

- CN13** Clout Nails (13mm Galvanised - QTY 230)
- PP25** Panel Pins (25mm - QTY 140)
- N40** Nail (40mm Galvanised - QTY 50)
- NG5** Nail (65mm Bright - QTY 40)
- CB80** Coach Bolts (80mm - QTY 8)

FX05 - NAIL KITS EXTRA LARGE

For Shed Products With 14ft to 20ft Sides:

- CN13** Clout Nails (13mm Galvanised - QTY 450)
- PP25** Panel Pins (25mm - QTY 200)
- N40** Nail (40mm Galvanised - QTY 85)
- NG5** Nail (65mm Bright - QTY 100)
- CB80** Coach Bolts (80mm - QTY 8)

FX06 - NAIL KITS HEAVY DUTY For Heavy Duty Shed Products:

- CN13** Clout Nails (13mm Galvanised - QTY 450)
- PP25** Panel Pins (25mm - QTY 200)
- N40** Nail (40mm Galvanised - QTY 85)
- NG5** Nail (65mm Bright - QTY 20)
- N100** Nail (100mm Bright - QTY 100)
- CB100** Coach Bolts (100mm - QTY 8)

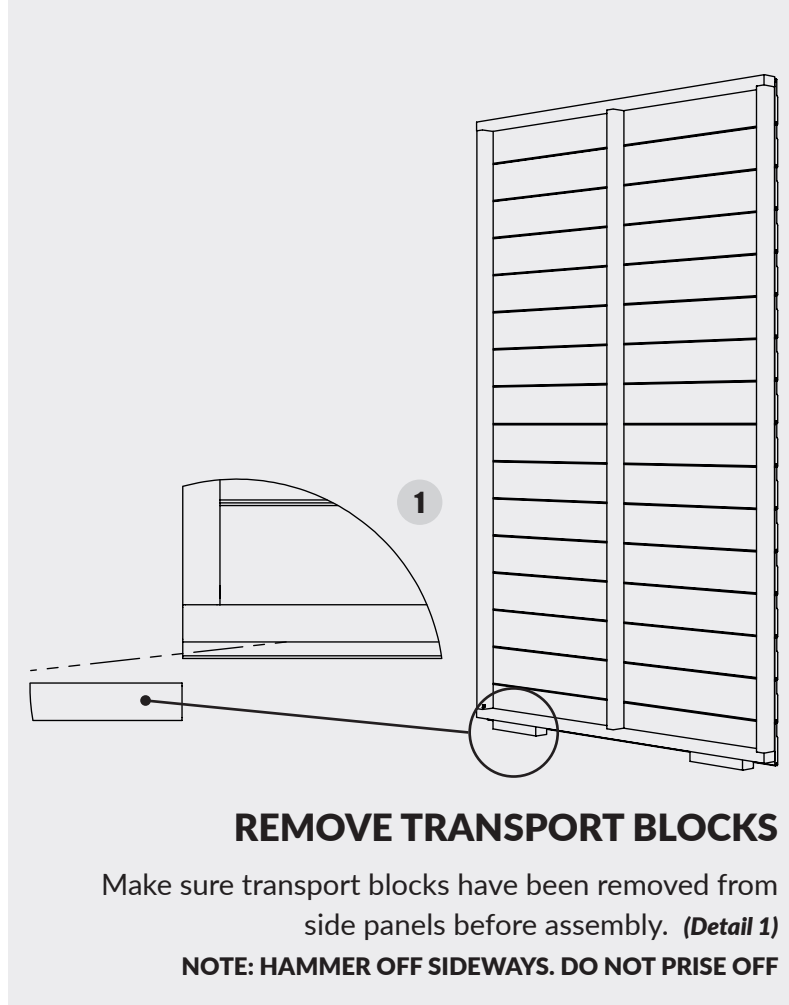

BUILDING PACK CONTENTS:

For full details of what should be included please see the itemised packing list that is supplied with the delivery. They are also available on request in pdf form from our helpful Customer Support team – please call: **0113 205 4189** or use the “Items Delivered Query” form at [tigersheds.com/contact](https://www.tigersheds.com/contact).

- Assembly is straightforward if you follow these step-by-step instructions.
- We recommend getting everything aligned properly before screwing together and that **screw holes should be pre-drilled to avoid splitting the timber.** *(Do not come pre-drilled).*

IMPORTANT

- Before assembly, please make sure you have a suitable base ready to erect your building on.
- Your base **MUST** be firm and level to ensure that the building is assembled properly and is square.
- **DO NOT** start your build until you have checked that all the parts of your building are present, correct and in a suitable condition.
- Panels may have become twisted during loading/unloading and/or transportation. Please check that all framing and cladding are square before beginning assembly.
- Make sure all transport blocks have been removed from panels.
- If you are organising a third party to install your building, it is best practice not to schedule this immediately on receipt of your order, to give you time to check your delivery

Step 1:

LAYING THE FLOOR

- **SINGLE FLOOR** - Lay floor down in the desired position. *(Detail A1)*
- **MULTI FLOOR** (excluding 10x8 & 12x8) - Lay floors down in the desired position and butt together. *(Detail A2)*
Join using 4x N65 evenly spaced through floor bearers at an angle. *(Detail A3)*
- **MULTI FLOOR** - 10x8 & 12x8 models. The bearers and floor boards may run in the opposite direction.
Butt together as shown. *(Detail A4)*
Join using 4x N65 evenly spaced through floor bearers at an angle. *(Detail A5)*

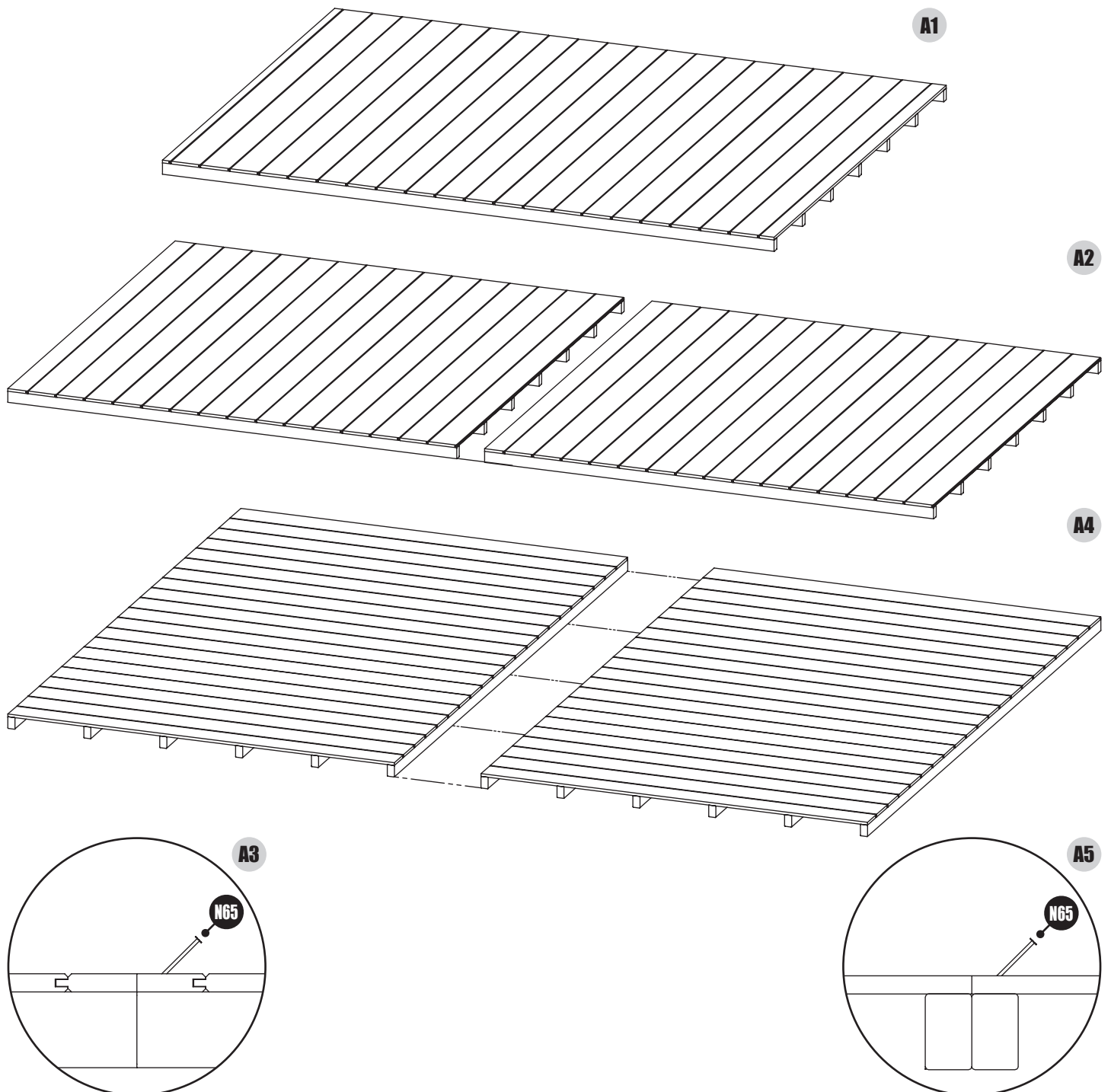

Step 2:

INSTALLING SIDE AND GABLE PANELS

- Position one end gable and side panel as shown. *(Detail B1)*

NOTE: CHECK THAT ALL PANELS ARE AT RIGHT ANGLES TO EACH OTHER AND THE FLOOR.

NOTE: CHECK ALL TRANSPORT BLOCKS HAVE BEEN REMOVED BEFORE FITTING PANELS.

- Secure together with 5x N40 evenly spaced. *(Detail B2)*
- Repeat process for remaining gable and side panel.

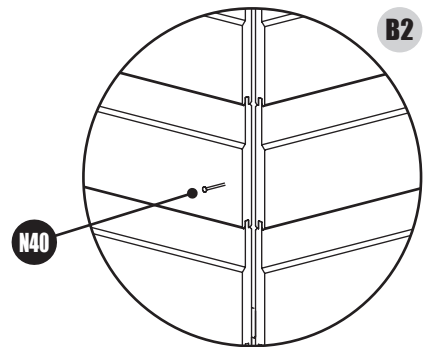
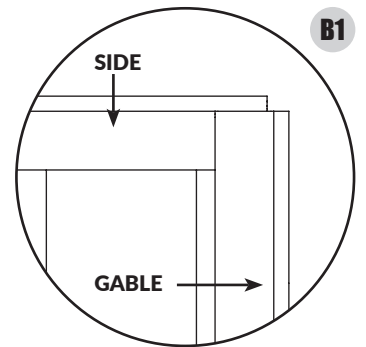
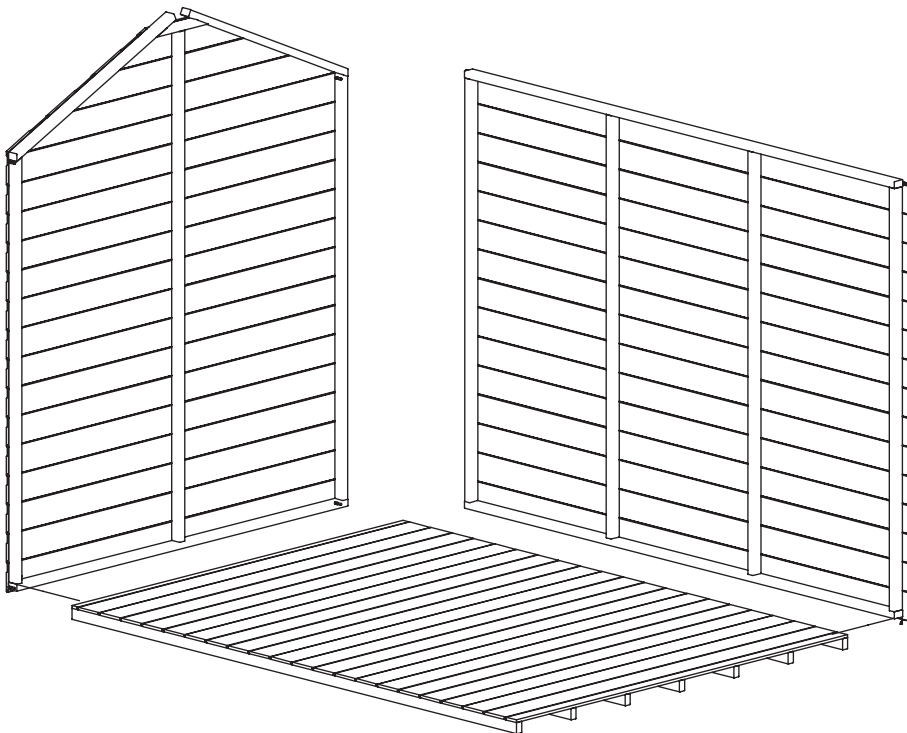

- For side panels made of 2 or more sections, secure together using 3x N65 evenly spaced through internal framework. *(Detail B3 & B4)*

NOTE: FOR HD FRAMING PRODUCTS, USE N100.

DO NOT FIX TO FLOOR.

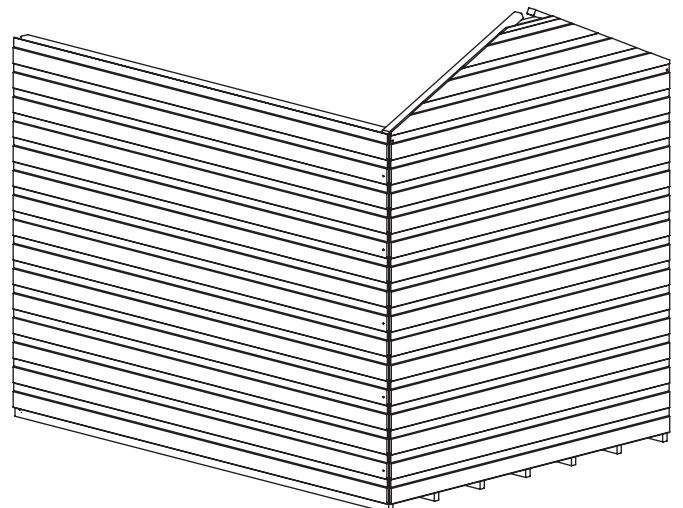
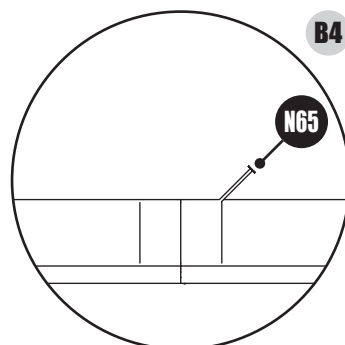
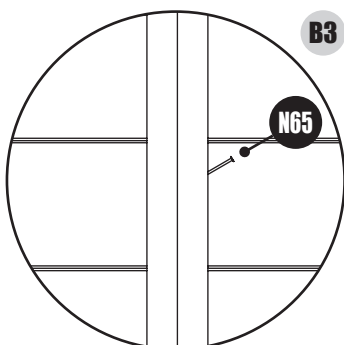

Step 3:

SECURING SIDE AND GABLE PANELS

- Locate pre-drilled holes in gable panels. **(Detail C1)**

NOTE: THESE MAY HAVE COVERED OVER DURING PANEL COATING PROCESS. THEY MAY RESEMBLE NAIL HEADS.

- Use 4x CB80 per gable, through the pre-drilled holes in each gable, from the outside. **(Detail C2)**

NOTE: DO NOT FULLY TIGHTEN.

NOTE: FOR HD FRAMING BUILDINGS, USE CB100.

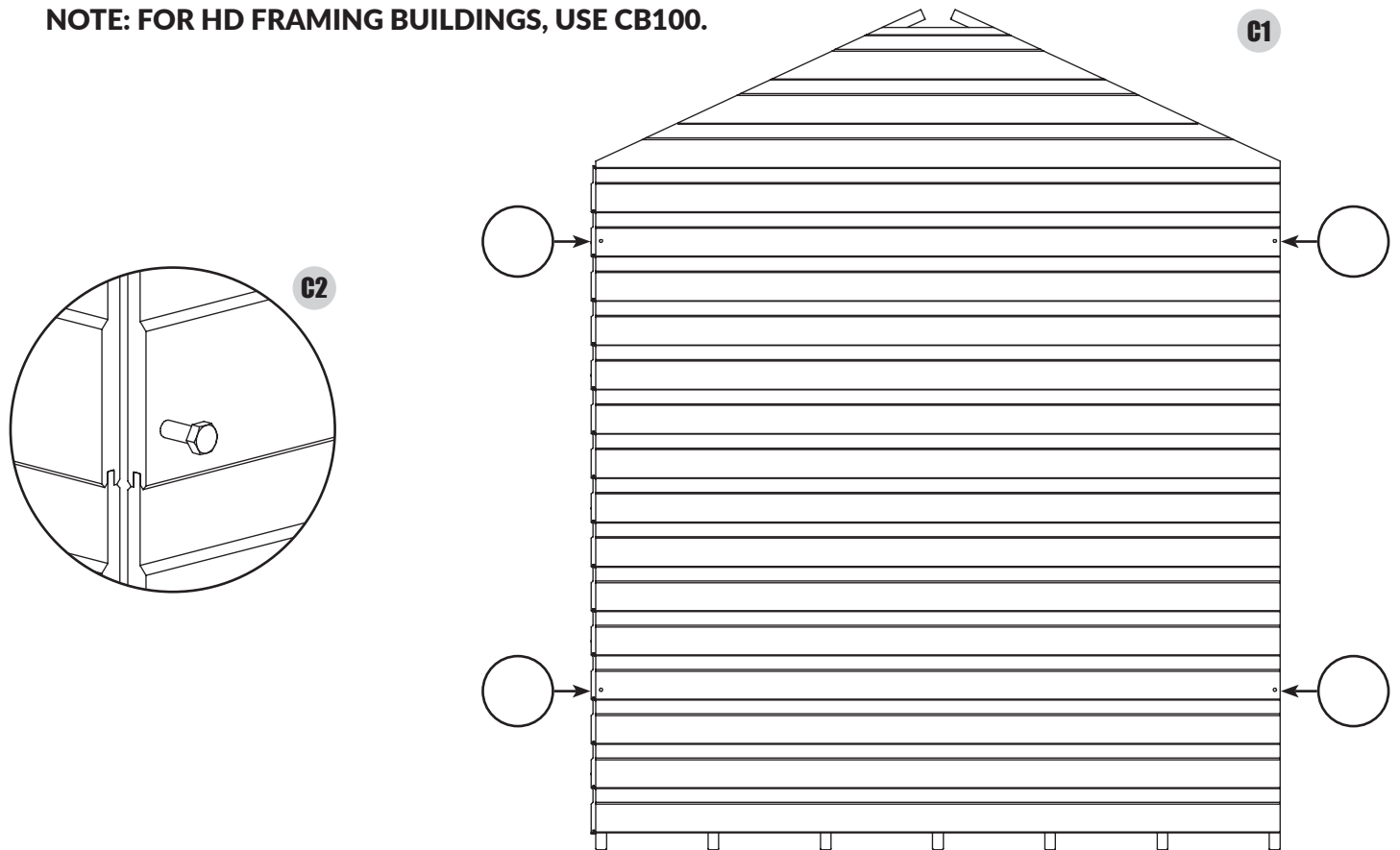

- Check panels are square by measuring between points shown. **(Detail C3)**

(Detail C3)

If measurements are equal, your panels are square. If not, manually adjust to suit.

NOTE: DO NOT TRIM.

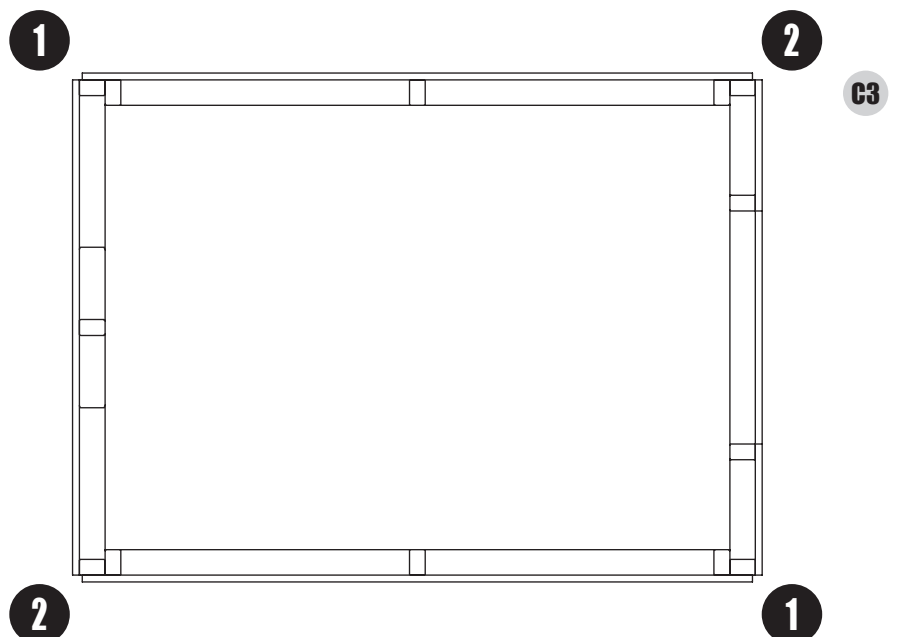

- Secure panels to the floor using 2x N65 per panel. Ensure the N65 are driven through the panels and into the floor bearers. *(Detail C4)*

NOTE: PANELS HAVE BEEN REMOVED FOR CLARITY.

NOTE: FOR HD FRAMING BUILDINGS, USE N100.

- Tighten 8x CB80. *(Detail C5)*

NOTE: CHECK THAT ALL PANELS ARE AT RIGHT ANGLES TO EACH OTHER AND THE FLOOR.

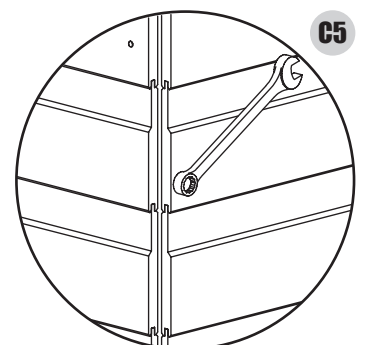
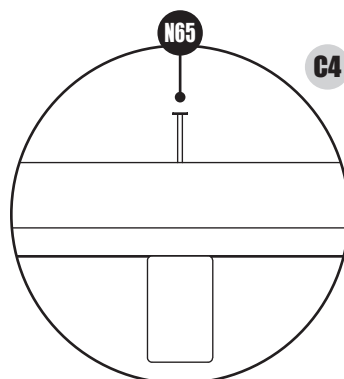
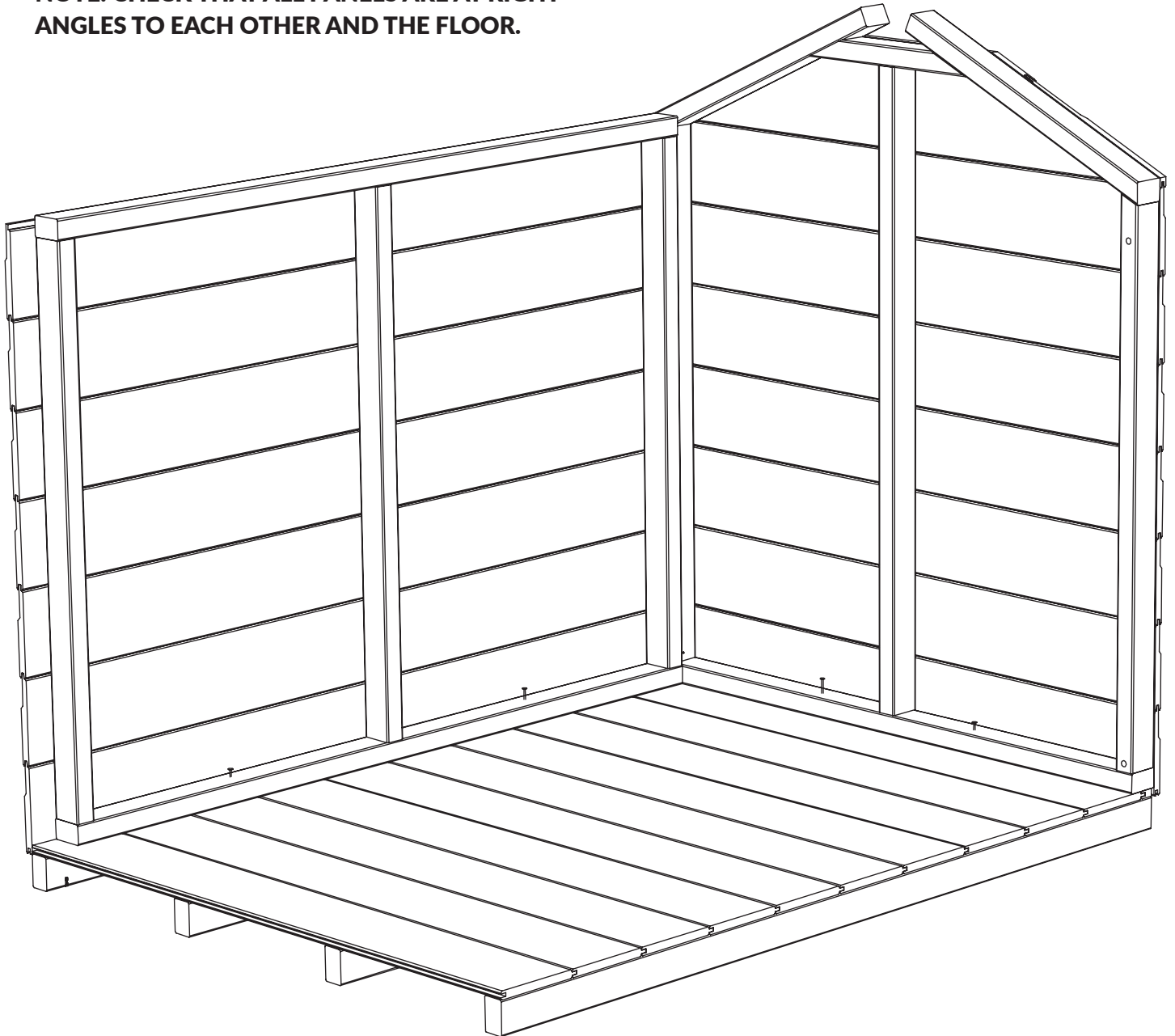

TOP TIP

Use the line of nails securing the floorboards to the bearers as a guide to make sure you correctly secure panels to the floor.

Step 4:

INSTALLING ROOF TRUSSES *(Certain Sizes Only)*

- Before fitting roof panels, if supplied, fit apex truss. Products with sides 10ft - 19ft are supplied with x1 truss (inc. clips) for centre of building. 20ft models are supplied with 3x trusses (inc. clips) to be equally spaced.
- Carefully remove metal “Z” clips that are attached to the rafter of the roof truss. **(Detail D1)**
- Reattach to the ends of the truss arms using 2x N40. **(Detail D2)**
- Place truss in position and secure through the “Z” clips into upright framing in the panels using 2x N65 per clip. **(Detail D3)**
- Repeat for all other clips.

NOTE: CHECK THAT ALL PANELS ARE AT RIGHT ANGLES TO EACH OTHER AND THE TRUSS.

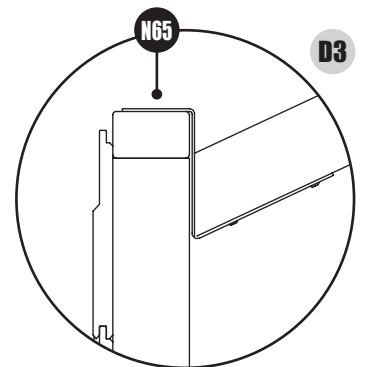
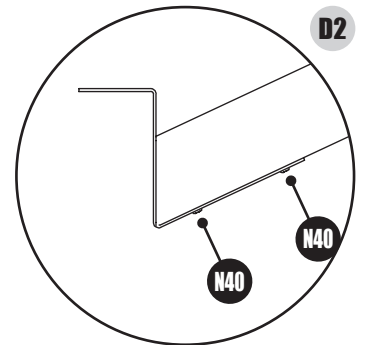
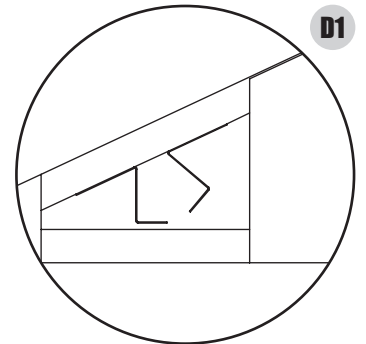
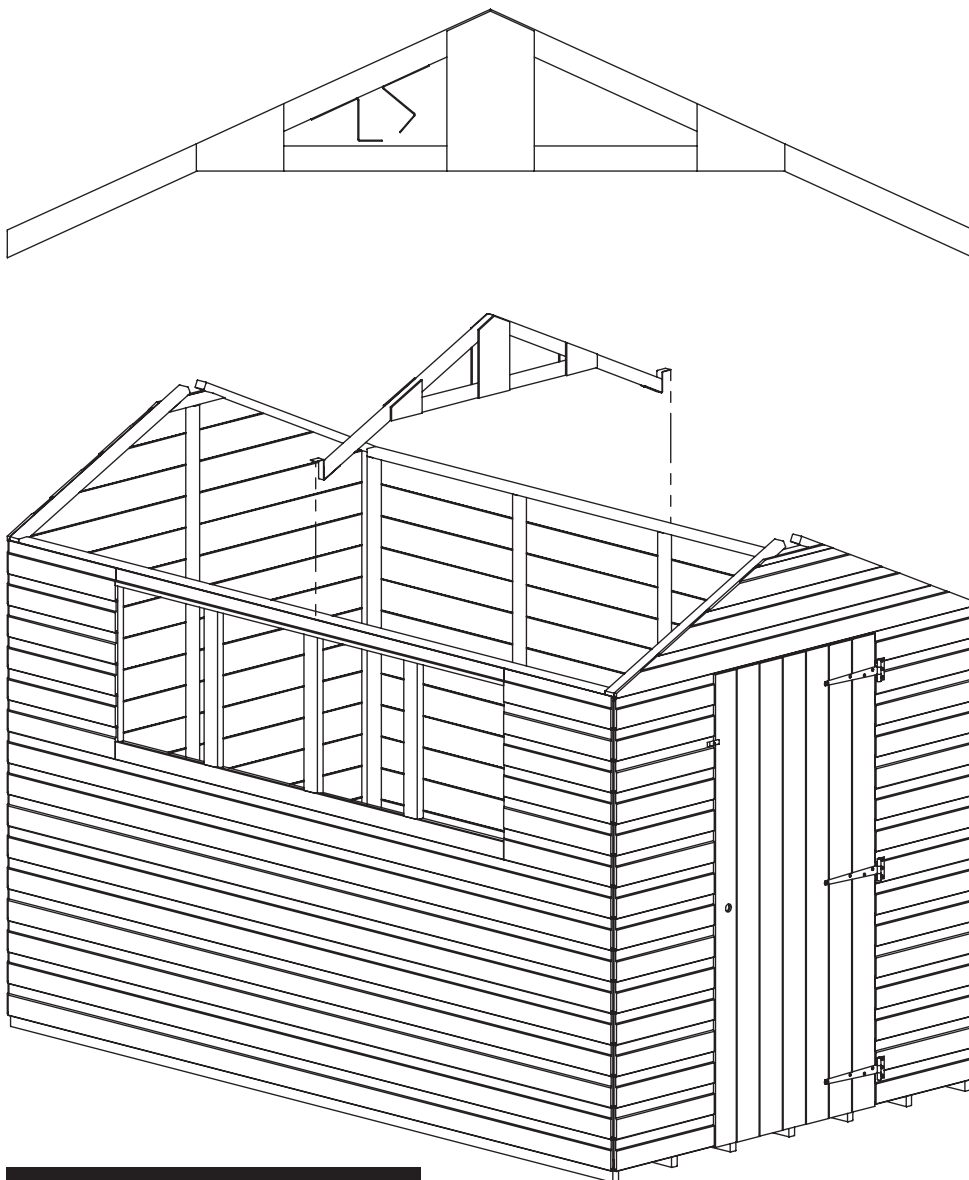

TOP TIP

Have someone hold the truss while you fix to the panels. This will avoid twisting and tipping.

Step 5:

SINGLE PIECE ROOF INSTALLATION

- Attach roof panels as shown. There will be a slight gap between the roof panels at the apex of shed. **(Detail E1)**
 - Secure apex purlins by pushing panels together and fixing with 6x N65 evenly spaced along length per panel. **(Detail E2)**
- NOTE: FOR HD FRAMING PRODUCTS, USE N100.**

TOP TIP
You may need someone to hold roof panels together while you secure roof panels at the apex.

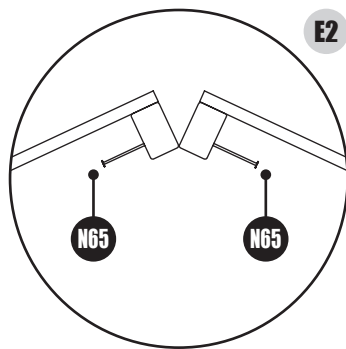
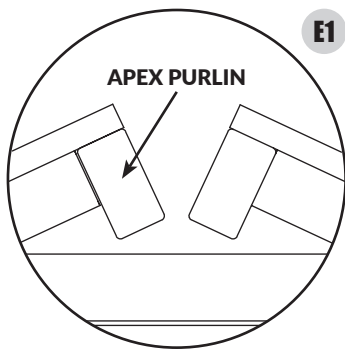
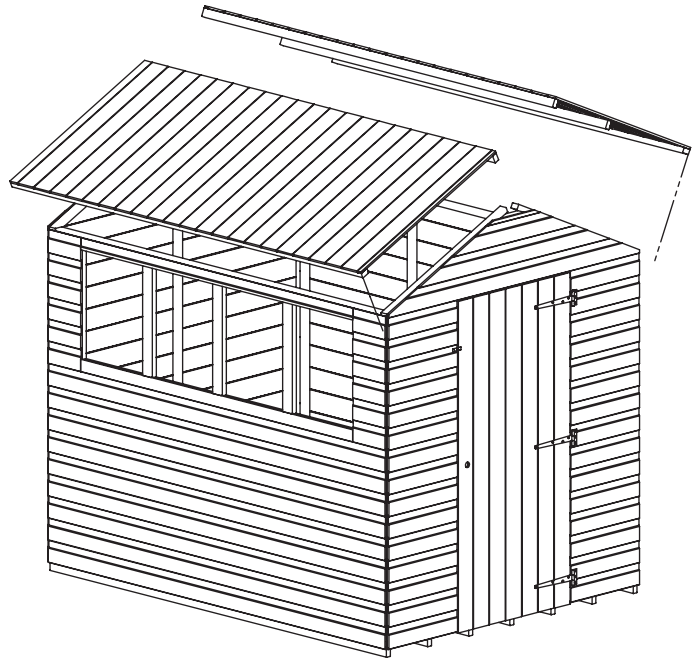

- Secure roof panels to the side panels using 3x N65 through upright framing in panels. **(Detail E3)**
- Secure roof panels to the gables using 3x N40 through the angled framing. **(Detail E3)**

TOP TIP
If your roof panels do not sit correctly, it suggests the building is not sitting square. Check that the building isn't twisted by lifting two opposite corners of the building to straighten it out. This should bring the roof panels into alignment for you to nail into position.

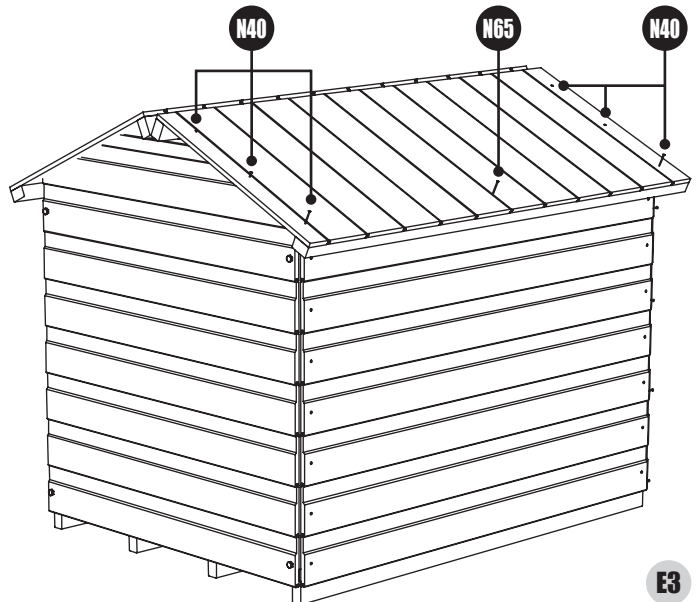
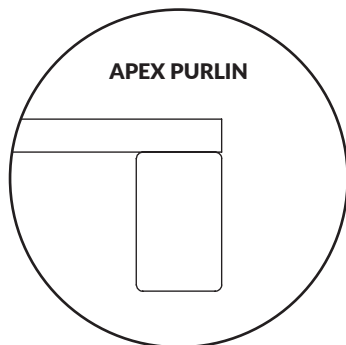
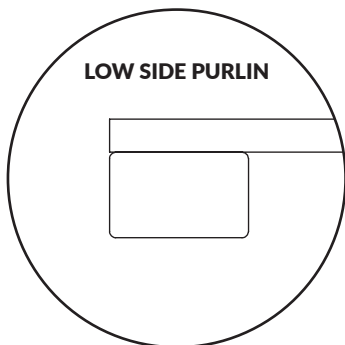

E3

Step 5b: ⓘ

MULTI PIECE ROOF INSTALLATION

- For roofs that come in 4 sections. Layout panels for each side as shown on a flat, dry surface and secure together along apex purlin (and any internal purlins) using 600mm batons supplied in polytube pack. Use x4 N65 per baton so that roof panel side is one piece. *(Detail E4 & E5)*

NOTE: FOR HD FRAMING PRODUCTS, USE N100.

NOTE: ROOF PANEL SECTIONS THAT ARE JOINED TOGETHER MAY BE VERY HEAVY.

PLEASE TAKE CARE WHEN LIFTING INTO PLACE.

- Follow steps in Step 5 - Single Piece Roof to complete roof installation.

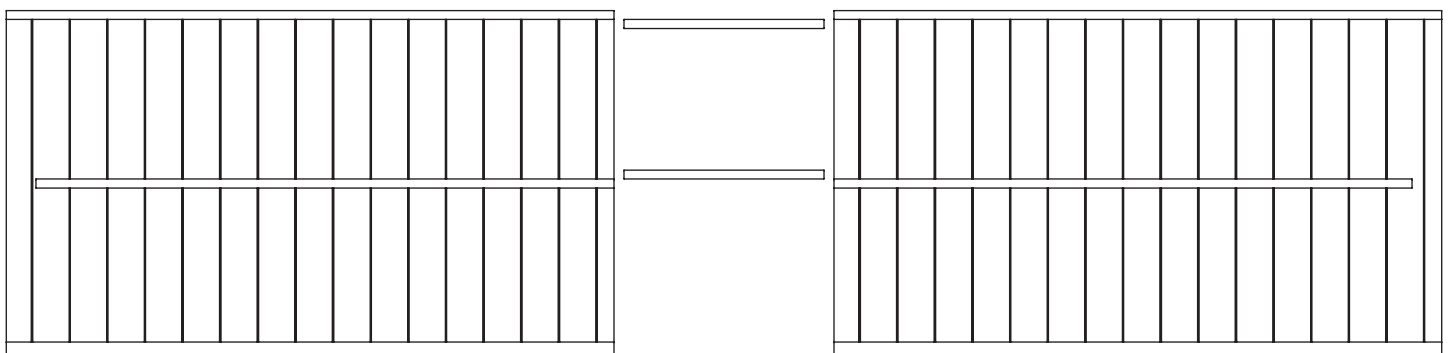

E4

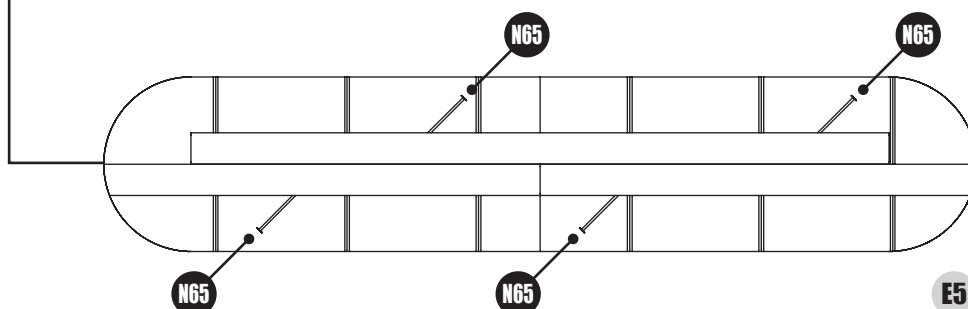
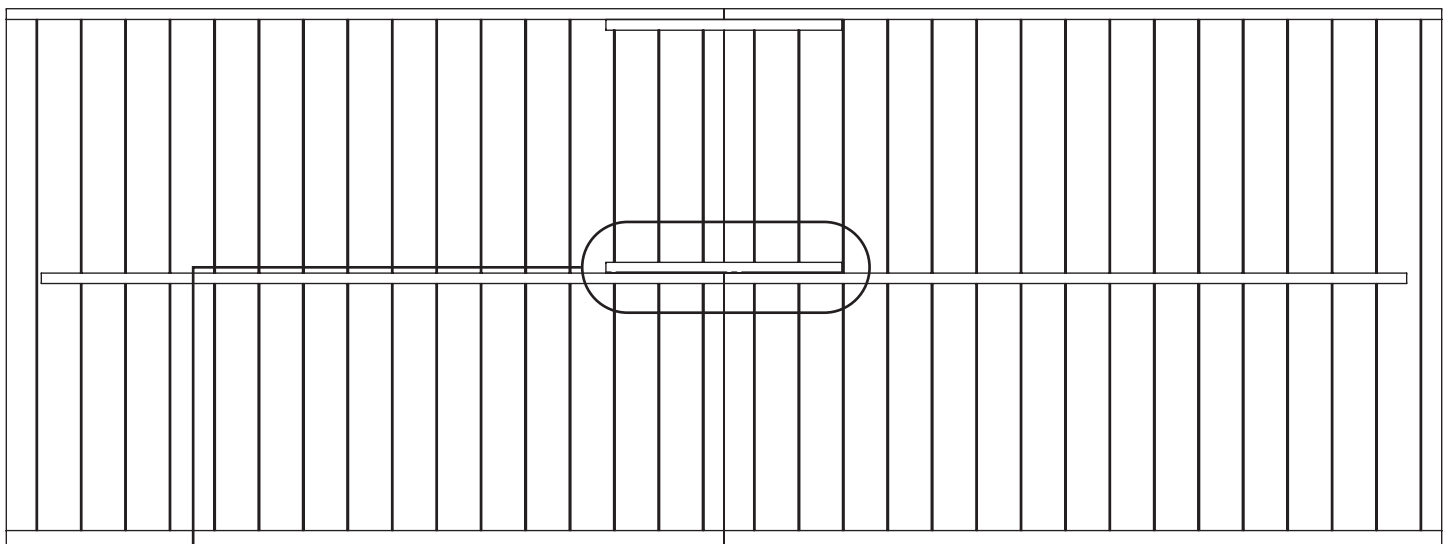

E5

Step 6:

FELTING THE ROOF - MEASURE AND CUT BEFORE FITTING

- Roll felt out onto a clean flat surface 30 minutes before you need it so it has a chance to flatten out.
- Measure length of roof and allow 35mm overhang at each end. Cut each strip of felt to size. Use a straight edge to guide cutting.
- Roll cut felt piece along low side of roof, Section 1, leaving sufficient overhang to fold down onto roof edge.
- Do not fold underneath roof. **(Detail F1 & F2)**
- Once felt is rolled out, fix felt to roof boards using CN13 at each end, making sure the felt is straight. Fix to roof skirting at approx. 100mm intervals. **(Detail F3)**
- Ensure the felt is tight, then secure the top side of felt using CN13 at approx. 100mm intervals.
- Repeat for remaining felt, working from the low side of roof to the high side, overlapping the felt by 75mm until the roof is fully covered.
- Fold the overhanging felt at ends under roof panel and tack in place.

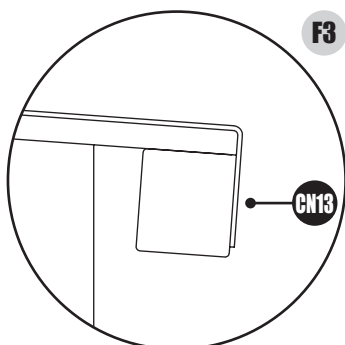
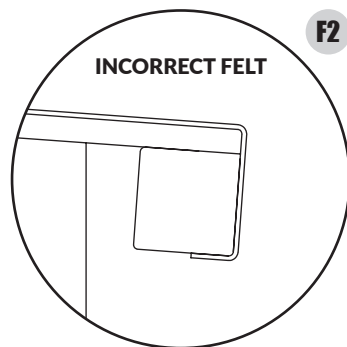
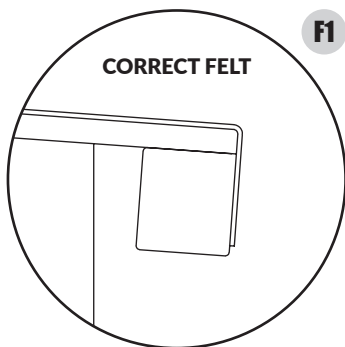
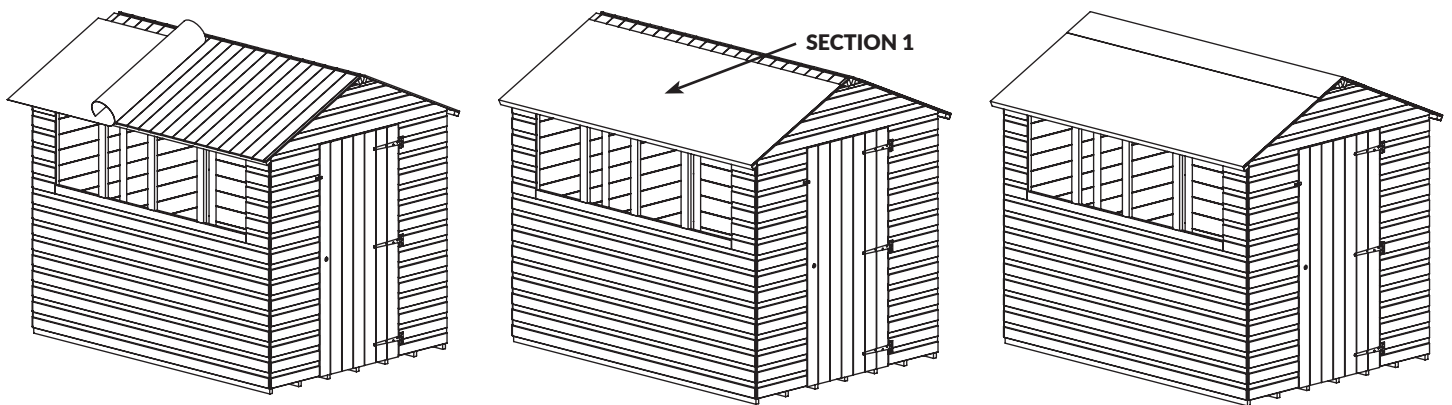

FELT REQUIREMENTS		
WIDTH OF SHED GABLE (FT)	LENGTHS OF 1m WIDE FELT	LENGTHS OF 0.5m WIDE FELT
3	1	1
4	2	
5	2	
6	2	1
7	3	
8	3	1
9	4	
10	4	

Each length of felt used is enough to cover the length of the roof plus overhang. Example: 6x4 Apex Shed will be supplied with roll of felt to cover 12ft plus overhangs at each end.

This is to be cut into two lengths by the customer to provide the correct coverage. (see table above)

Step 7:

FITTING FASCIA BOARDS (BARGEBOARDS) & FINIAL

- Fit bargeboards to the roof panels, trapping overhanging end of the felt in between the roof panel and bargeboard. Secure using 2x N40 per bargeboard through apex and low side purlins.

NOTE: THERE ARE NO BARGEBOARDS SUPPLIED FOR LOW SIDE OF ROOF AS THIS WILL PREVENT EFFECTIVE WATER DRAINAGE.

- Secure finial over the top of the bargeboards using 2x N40 per finial. (Optional)

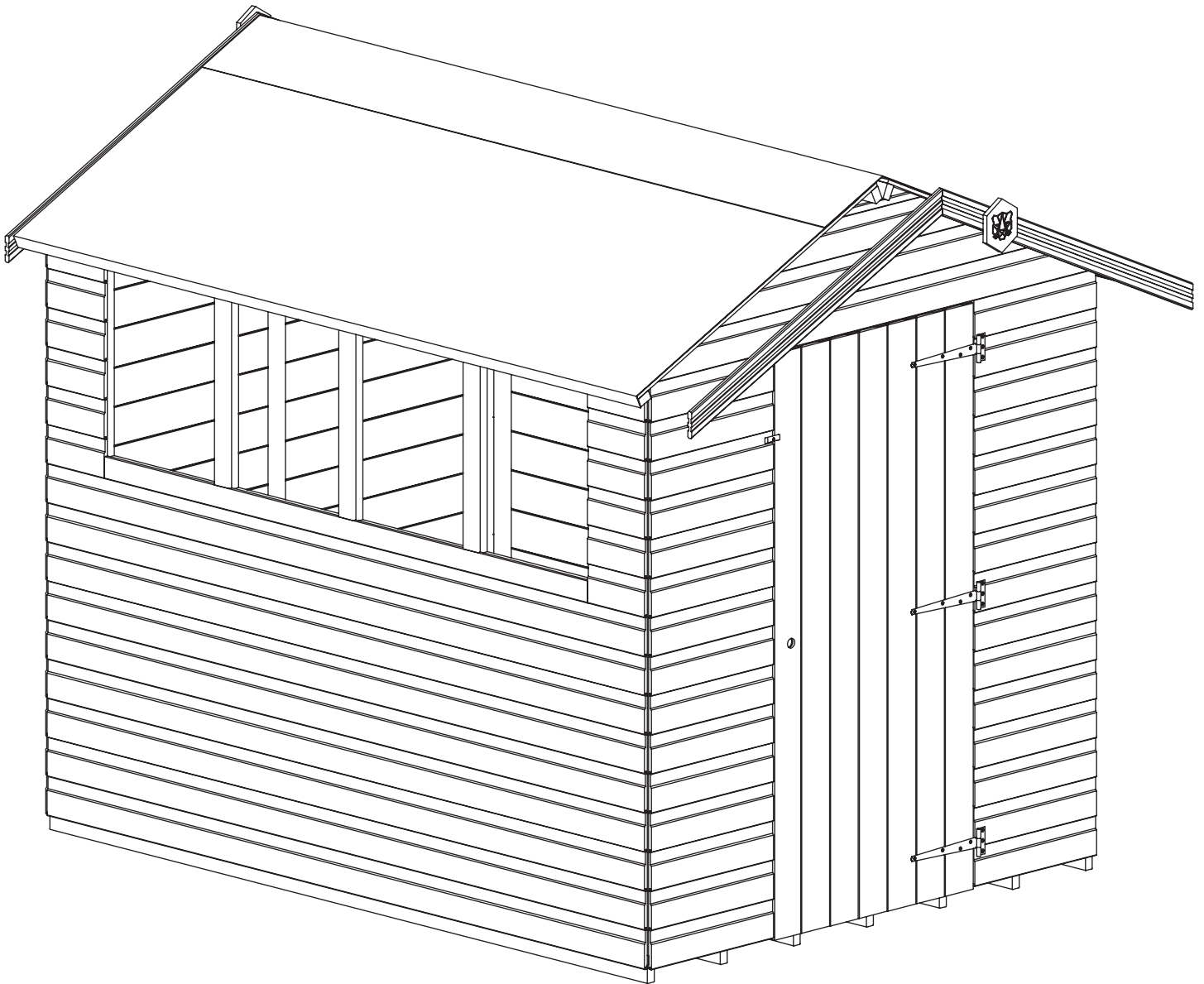

Step 8:

FIT CORNER STRIPS AND COVER STRIPS - CERTAIN SIZES ONLY

- Secure the corner strips at each corner of the shed with 4x N40 per corner strip.

NOTE: THESE CORNER STRIPS MAY NEED CUTTING TO SIZE.

NOTE: NOT TO BE CONFUSED WITH WINDOW BEADING.

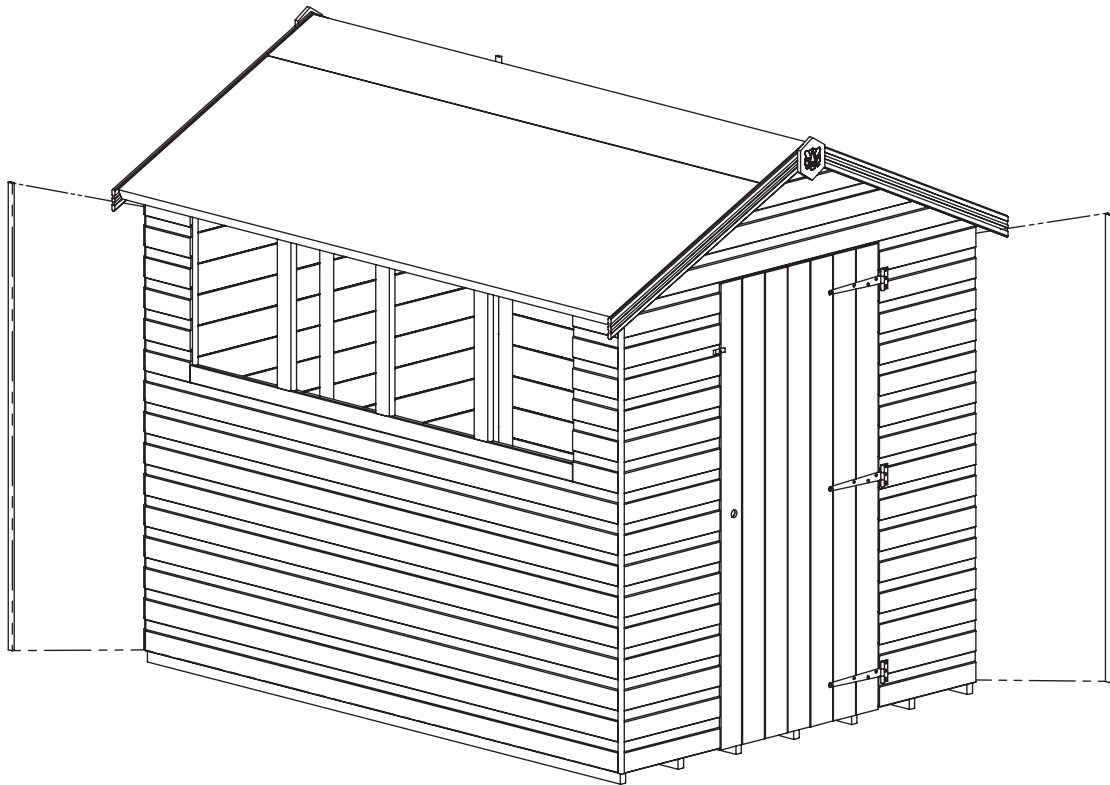

- On sheds with a join in the side panels, use cover strip to hide join. Secure to sides using 4x N40 per cover strip. *(Detail G)*

NOTE: THESE COVER STRIPS MAY NEED CUTTING TO SIZE.

NOTE: NOT TO BE CONFUSED WITH BARGEBOARD.

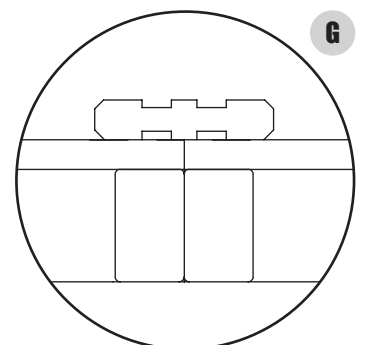
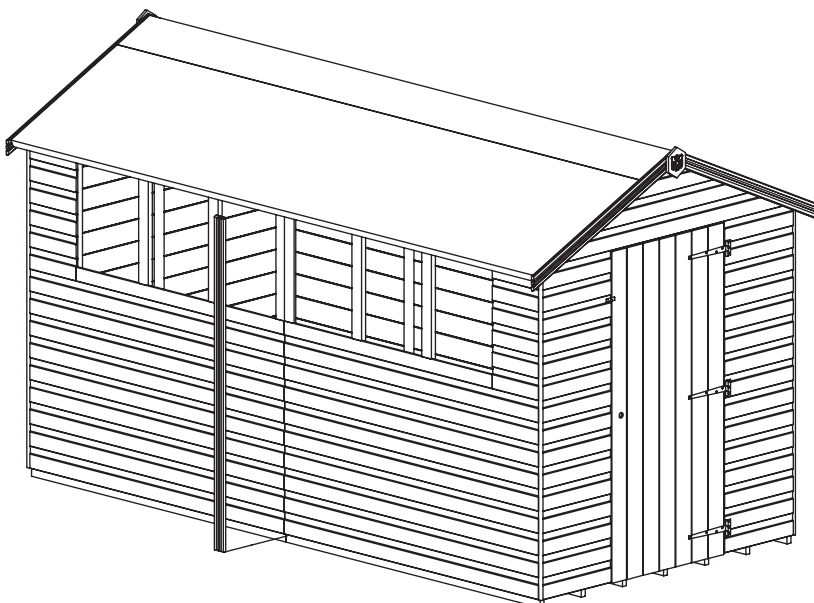

Step 9:

INSTALLING GLAZING

- Glaze windows by securing glass/styrene with PP25 supplied, from the inside. *(Detail H)*
NOTE: ALL WINDOWS MUST BE SEALED INSIDE AND OUT WITH SILICONE, PUTTY, OR ANY OTHER WATER-TIGHT SOLUTION. (NOT SUPPLIED).
NOTE: PLEASE DO NOT CONFUSE YOUR CORNER STRIPS WITH WINDOW BEADING. WE DO NOT SUPPLY WINDOW BEADING AS STANDARD WITH OUR BUILDINGS UNLESS ORDERED.
- Contact our friendly customer support team to order a standard window glazing kit, complete with beading and sealant.

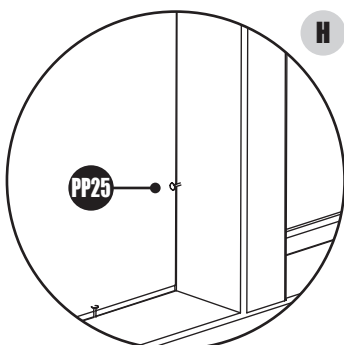
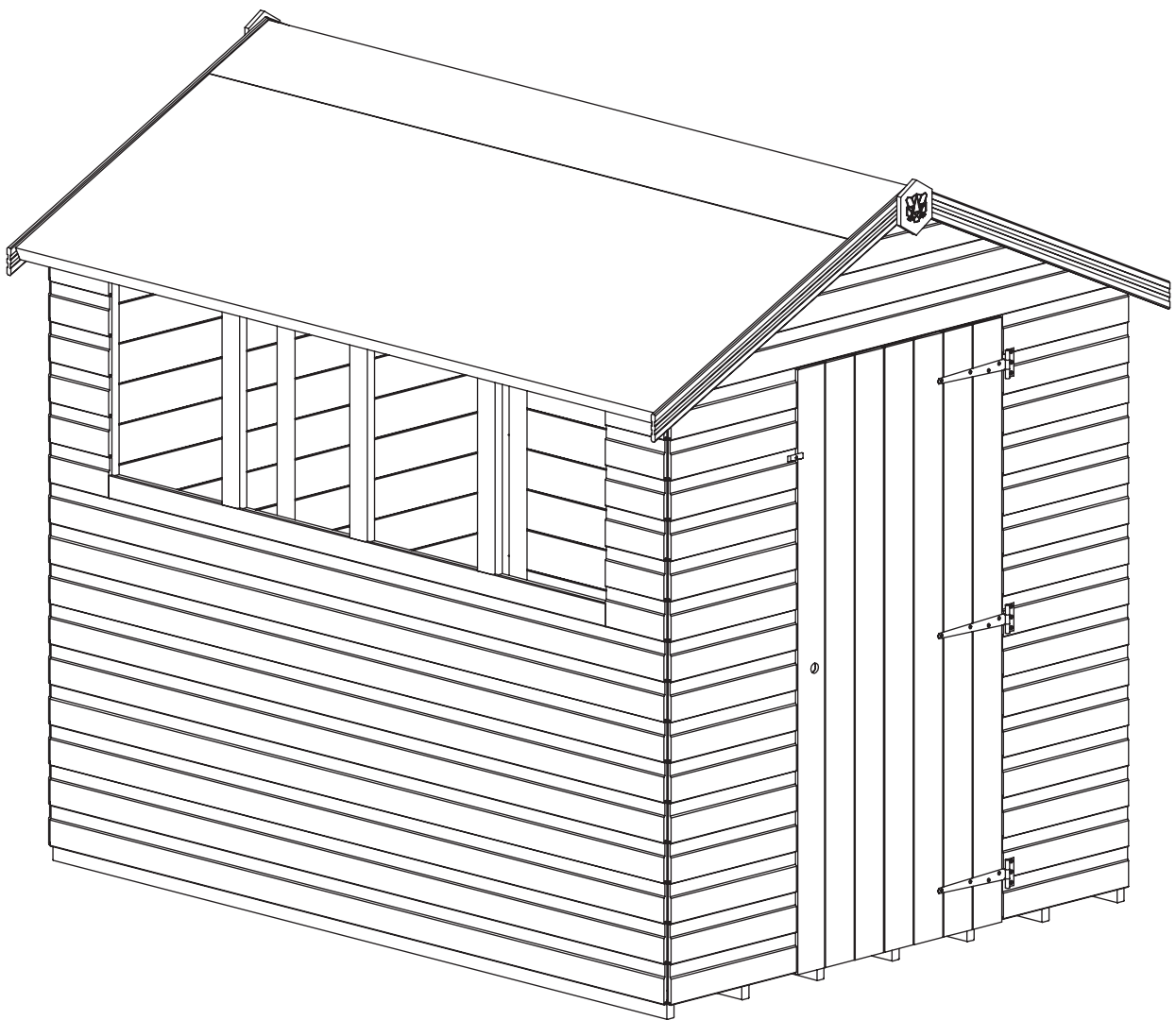

Step 10:

INSTALLING DOOR PULL

- Find comfortable height for supplied door pull handle.
- Secure handle to door using 4x 25mm (BS25) screws in the holes provided.
 - If door is made from interlocking boards and your chosen handle position does not match with existing door bracing, use supplied 150mm framing to fix handle screws into.
 - If chosen position matches existing bracing, secure directly into this.
 - For summerhouse doors, secure directly into the door frame.

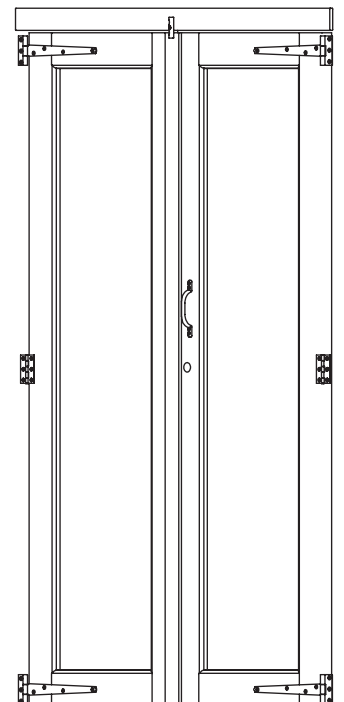
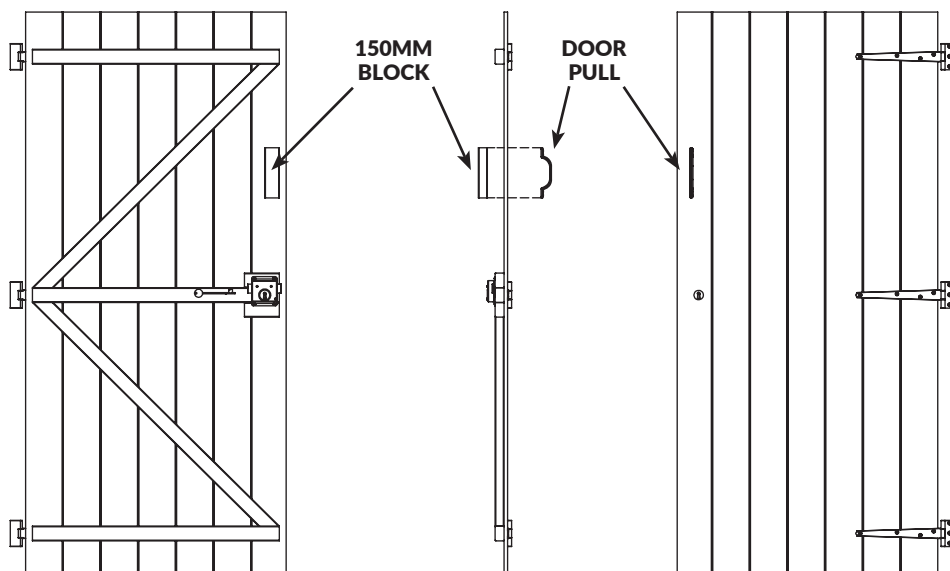
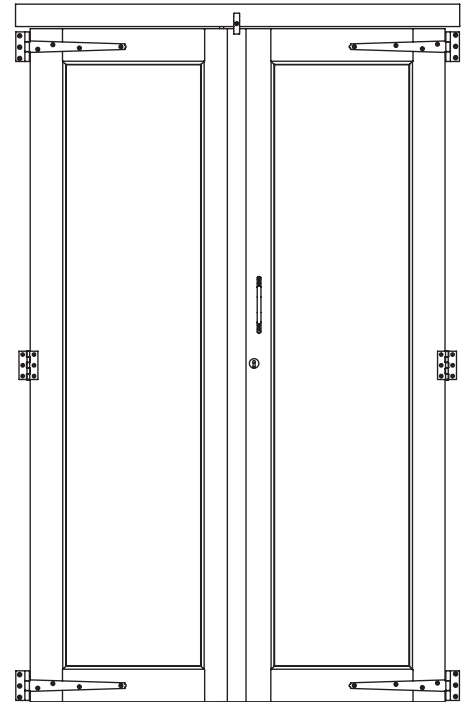
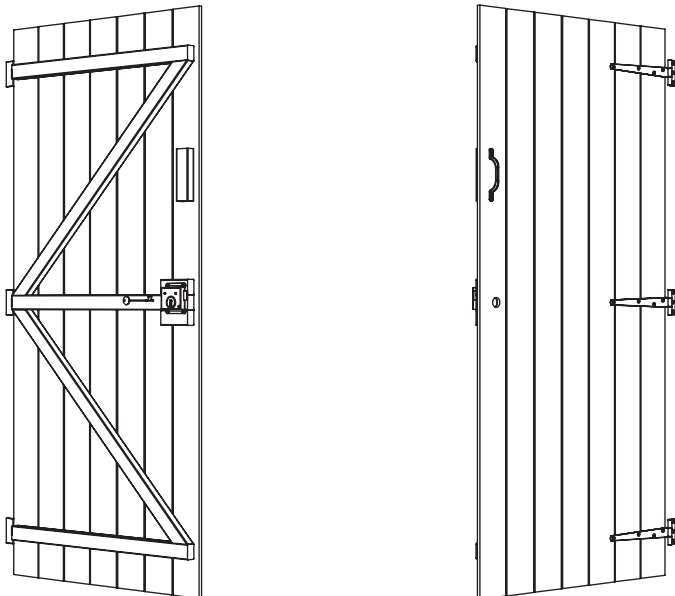



Head Office

Calverley Lane,
Rodley,
Leeds,
West Yorkshire,
LS13 1NP

Telephone: 0113 205 4189
Website: tigersheds.com
Email: customersupport@tigersheds.com



SCAN CODE!
TO VIEW GENERAL ASSEMBLY
GUIDE FOR APEX ROOF SHED



SCAN CODE!
TO SEE GENERAL ACCESSORY &
INSTALLATION VIDEO LIBRARY

