













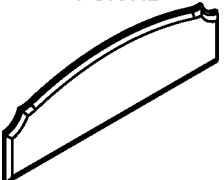
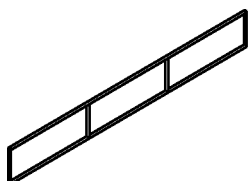
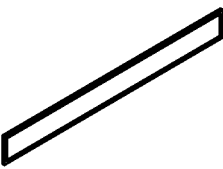
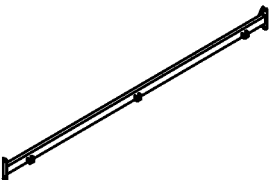
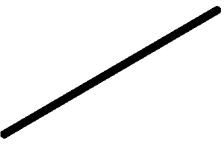



ASSEMBLY INSTRUCTION

CANOPY KING SIZE HEADBOARD AND FOOTBOARD CANOPY KING SIZE RAILS + REGULAR SLATS

A LEFT LOWER POSTS FOR HB 1pc 	B RIGHT LOWER POSTS FOR HB 1pc 	C LEFT EXTENTION LEG FOR FB 1pc 	D RIGHT EXTENTION LEG FOR FB 1pc 	E CUSHION FOR HB 1pc 
F HEADBOARD PANEL 1pc 	G FOOTBOARD PANEL 1pc 	H SIDE RAILS 2pcs 	I SLATS 3pcs 	J SUPPORT LEGS 6pcs 
K FINIAL 4pcs 	L BOLT 1/4",16MM 4pcs 	M BOLT 1/4",22MM 8pcs 	N BOLT 1/4",38MM 4pcs 	O BOLT 1/4",44MM 14pcs 
P BOLT 1/4",51MM 2pcs 	Q BOLT M4,17mm 4pcs 	R WASHER ϕ 16mm 26pcs 	S FLAT WASHER ϕ 12mm 4pcs 	T NUT 4X4MM 6pcs 
U ALLEN WRENCH 4X4MM 1pc 	V WRENCH 11.3MM 1pc 			

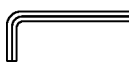
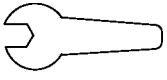
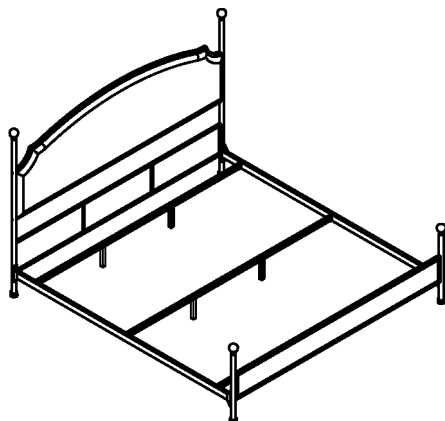

This page lists all the contents included in the box. Please take the time to identify the hardware as well as the individual components to this product. As you unpack and prepare for assembly, place the contents on a carpeted or padded area to protect them from damage.

1

Assemble the left lower posts (A) and the right lower posts (B) to the headboard panel (F) with 4pcs Bolt (L) then fastened using allen wrench (U).

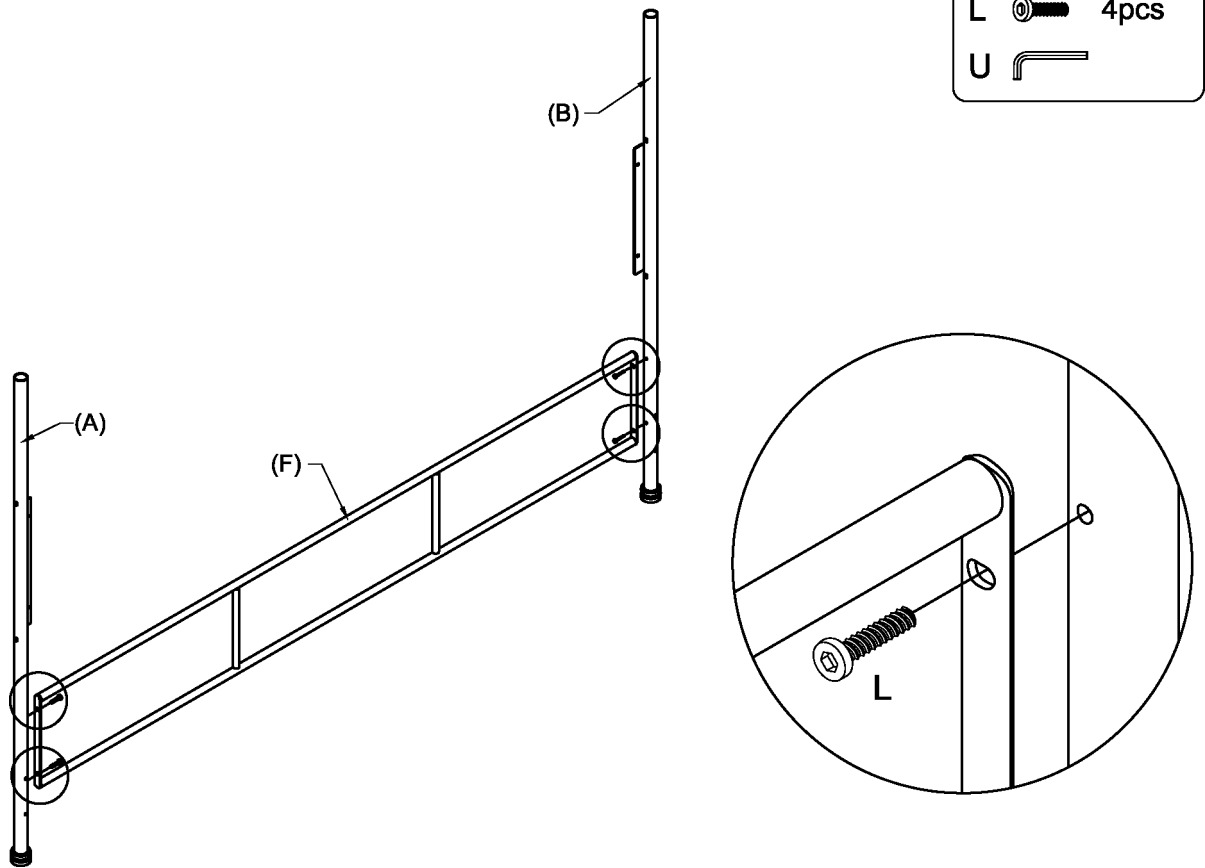
**2**

Assemble the cushion (E) to the left lower posts and the right lower posts with 2pcs bolt (O) , 2pcs bolt (P) with 4pcs bolt (Q) and 4pcs flat washer (S) then fastened using allen wrench (U) .

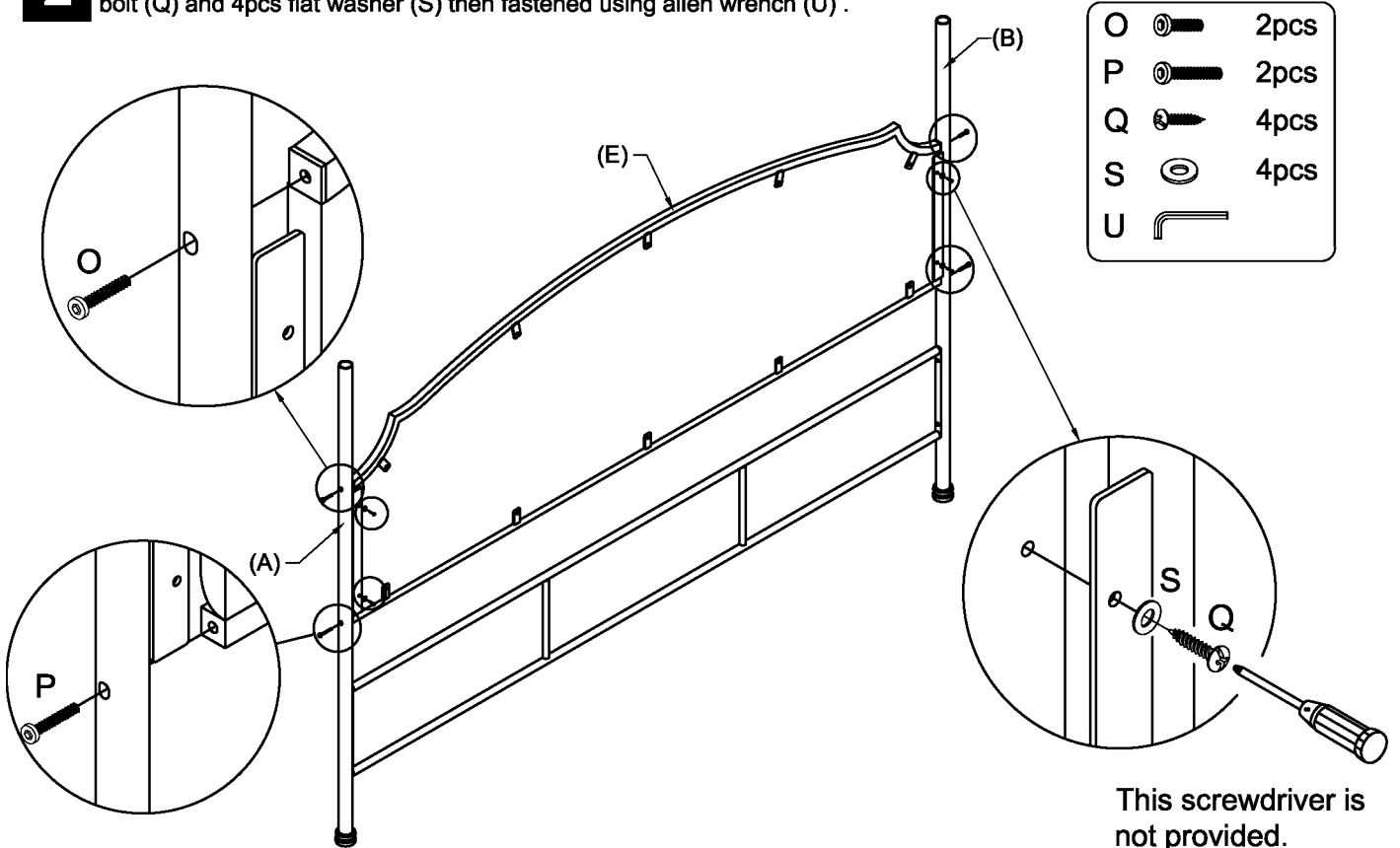

3

Assemble the left extension leg (C) and the right extension leg (D) to the footboard panel (G) with 4pcs bolt (N) then fastened using allen wrench (U).

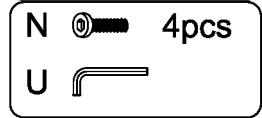
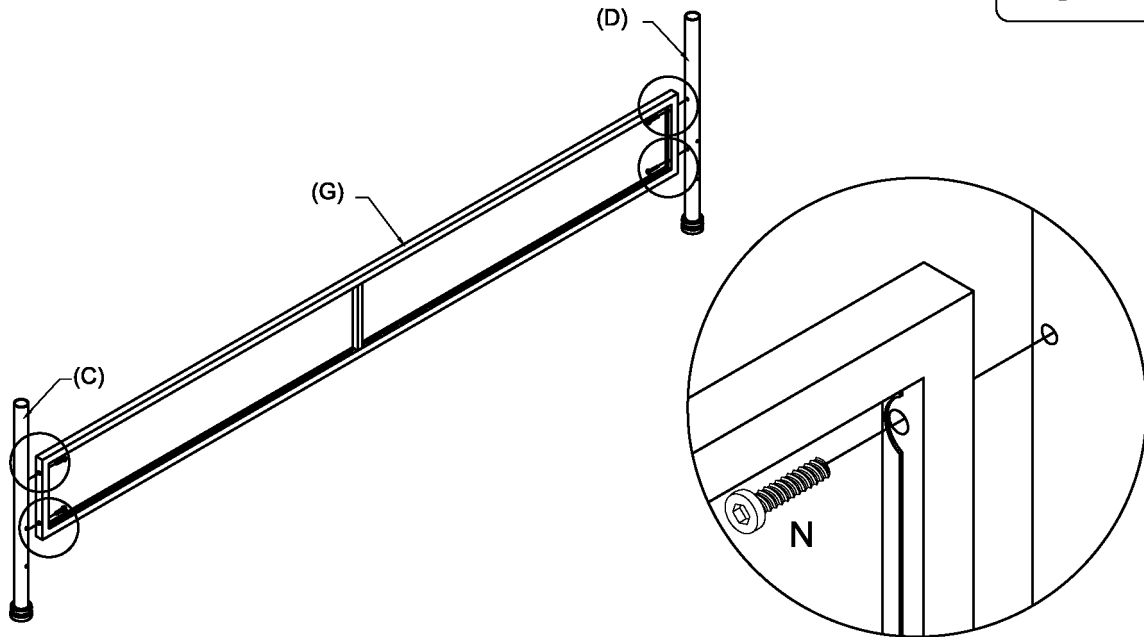
**4**

Assemble the side rails (H) to the left lower post (A) and the right lower post (B) with 4pcs bolt (M) and 4pcs washer (R); assemble the side rails (H) to the left extension leg (C) and the right extension leg (D) with 4pcs bolt (M) and 4pcs washer (R); then fastened using allen wrench (U).

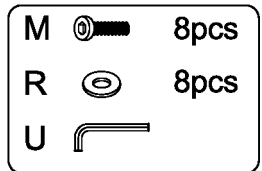
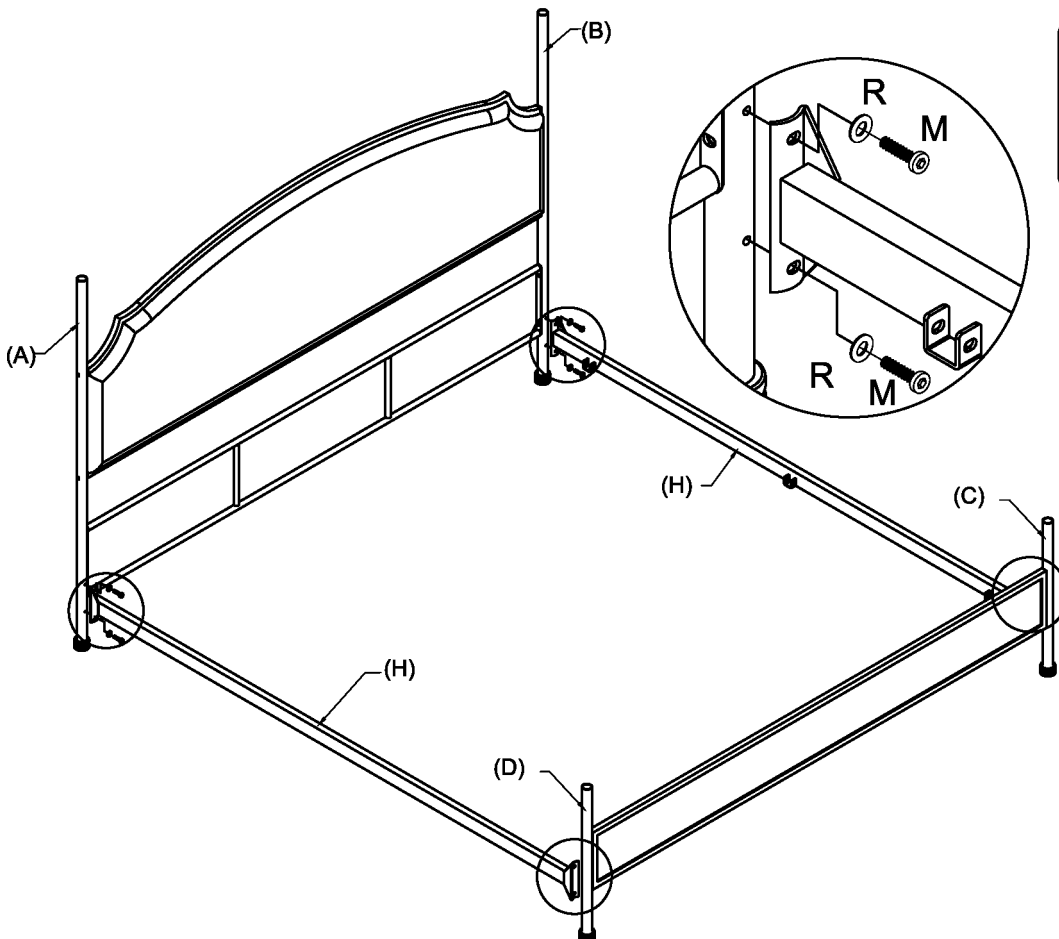

5

Assemble the support leg (J) to the slats (I) with 6pcs bolt (O) and 6pcs wrench (R) then fastened using allen wrench (U).

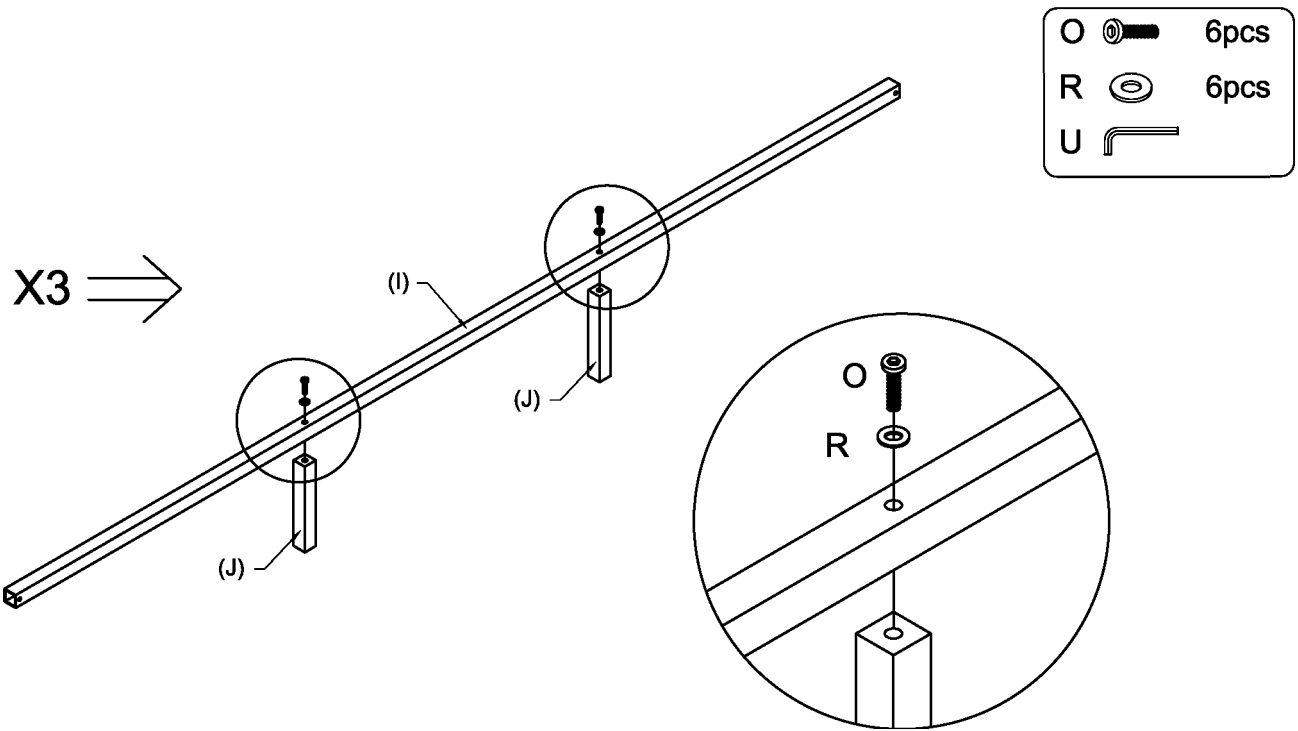

6

Assemble the slats (I) to the side rails (H) with 6pcs bolt (O), 12pcs washer (R), 6pcs nuts (T), then fastened using allen wrench (U) and wrench (V).

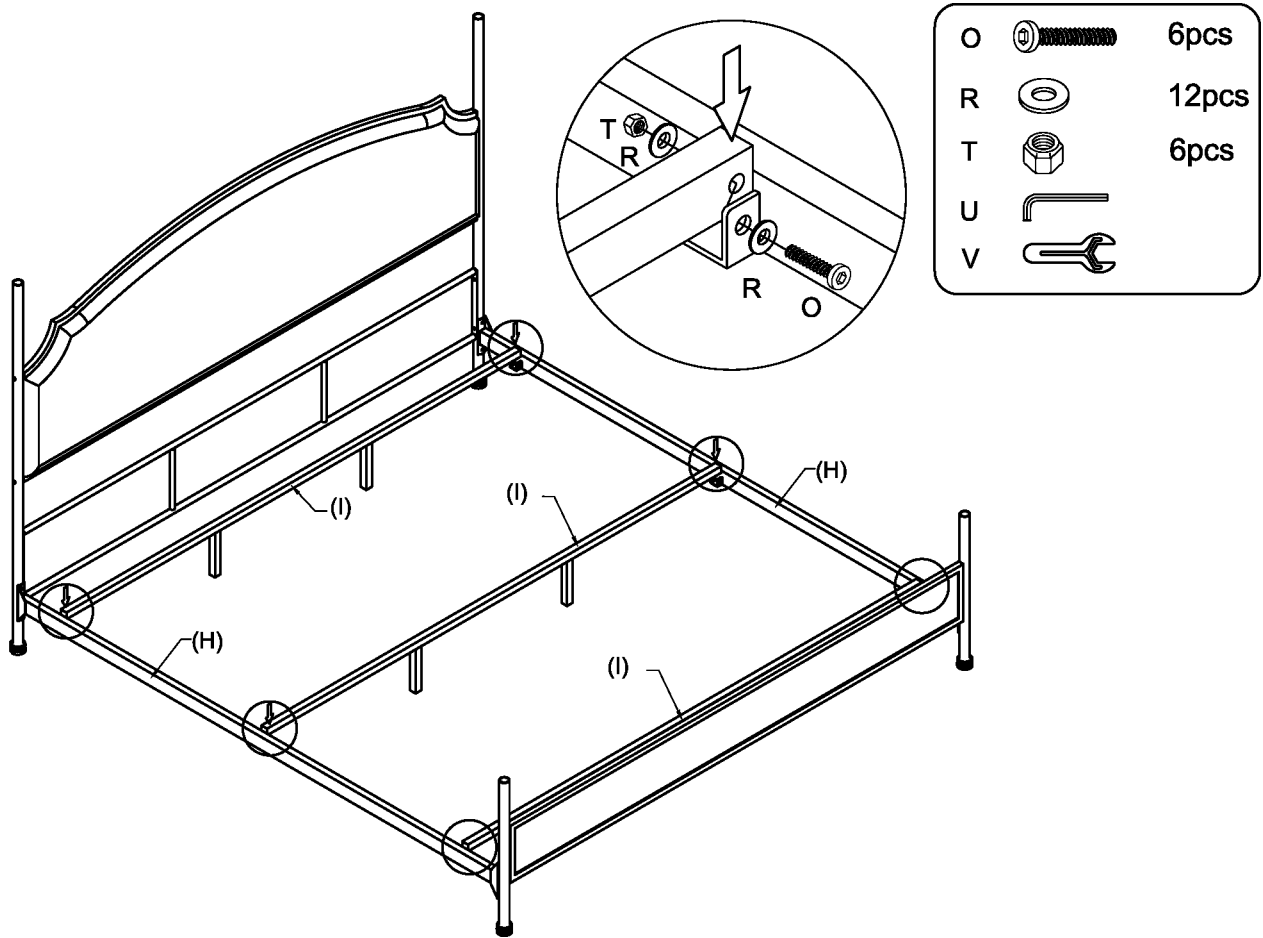

7

Assemble the finial (K) to the upper posts left lower posts (A), right lower posts (B), left extension leg (C) and right extension leg (D).

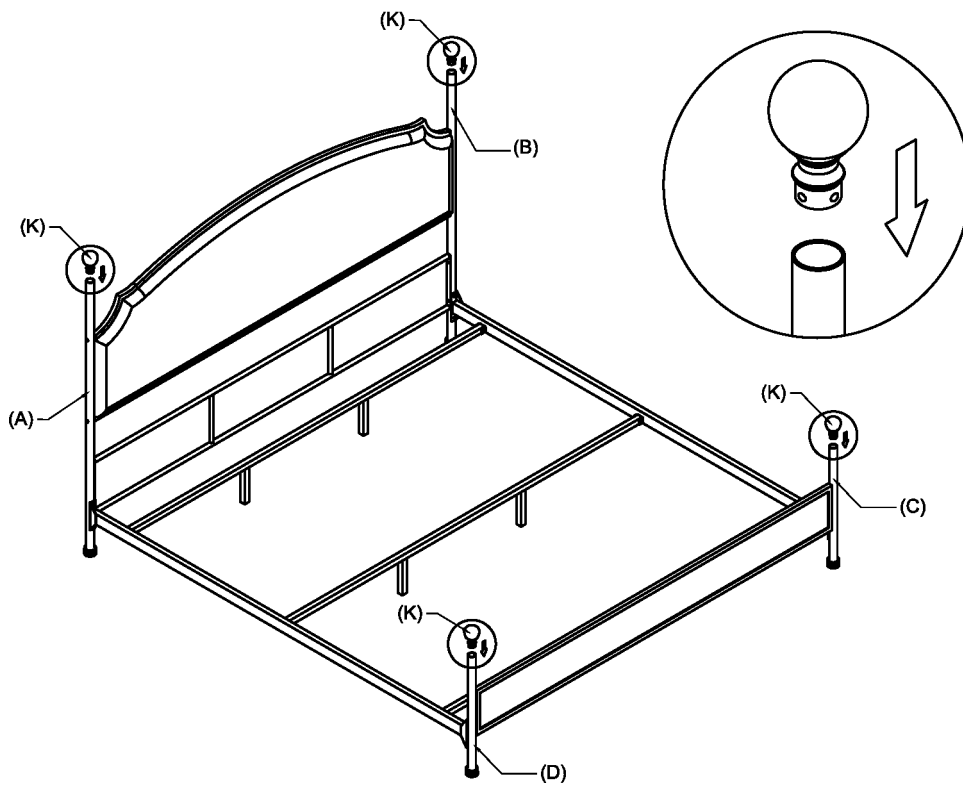
**8**

Completed.

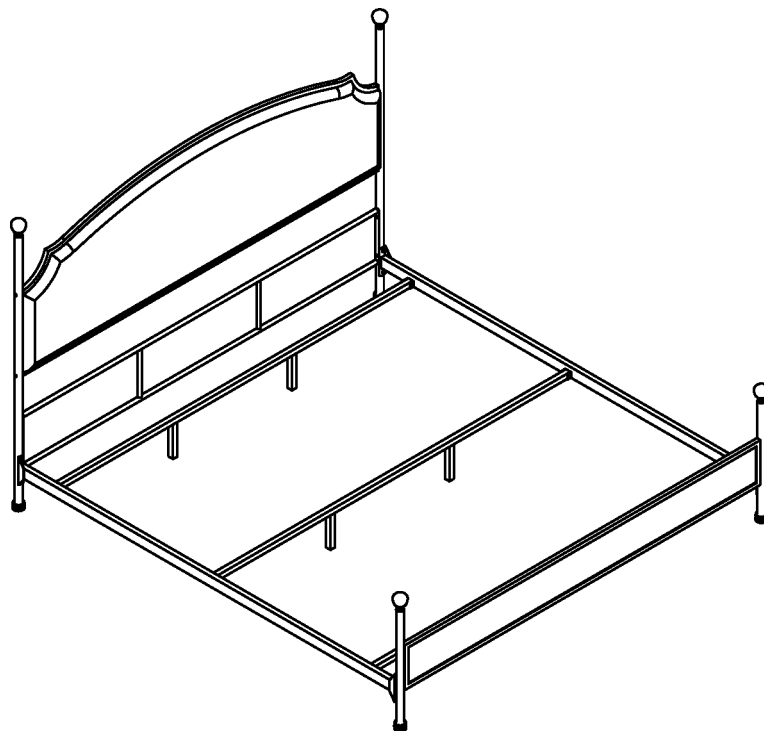

Cleaning & Care

Treat surface with care. Surface is resistant to scratches but is not scratch resistant. Clean surfaces with a dry or damp soft cloth. Do not use abrasive cleaners. Hardware may loosen over time. Periodically check that all connections are tight.