

ASSEMBLY INSTRUCTIONS

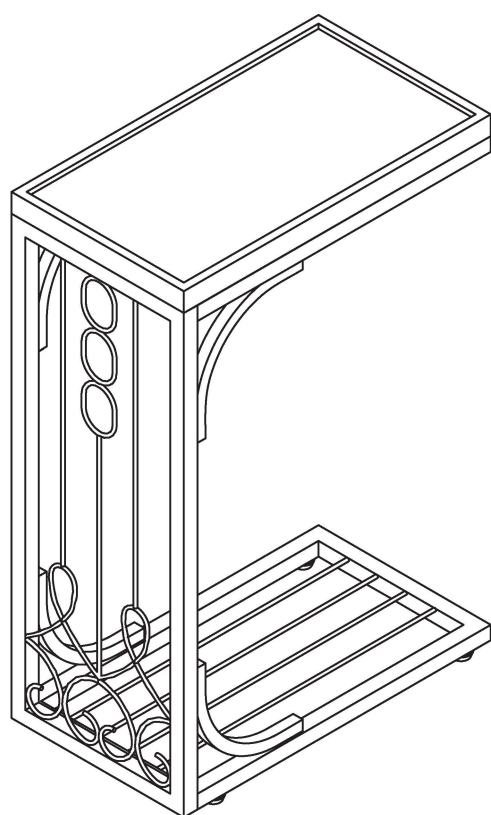

ASSEMBLY INSTRUCTIONS

ASSEMBLY TIPS:

1. Remove hardware from box and sort by size.
2. Please check to see that all hardware and parts are present prior to start of assembly.
3. Please follow attached instructions in the same sequence as numbered to assure fast & easy assembly.



WARNING!

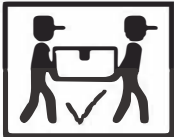

1. Don't attempt to repair or modify parts that are broken or defective. Please contact the store immediately.
2. This product is for home use only and not intended for commercial establishments.



ASSEMBLY TIME

30 MINUTES

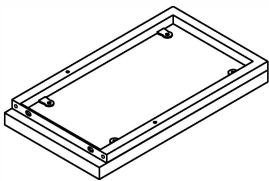
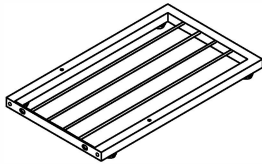
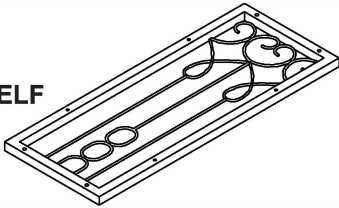
PARTS IDENTIFICATION

A	WOOD TOP		1PC
B	BOTTOM SHELF		1PC
C	SIDE SHELF		1PC
D	STRETCHER BAR		4PCS

NOTE:

Phillips head screw driver is required in the assembly process; however, manufacturer does not provide this item.

HARDWARE IDENTIFICATION

1 **BOLT**
 ($\Phi 1/4"$ x $1/2"$)  **4PCS**

2 **BOLT**
 ($\Phi 1/4"$ x $1"$)  **8PCS**

3 **ALLEN KEY**
 (4.0mm)  **1PC**

NOTE:
Phillips head screw driver is required in the assembly process; however, manufacturer does not provide this item.

ASSEMBLY INSTRUCTIONS STEP 1

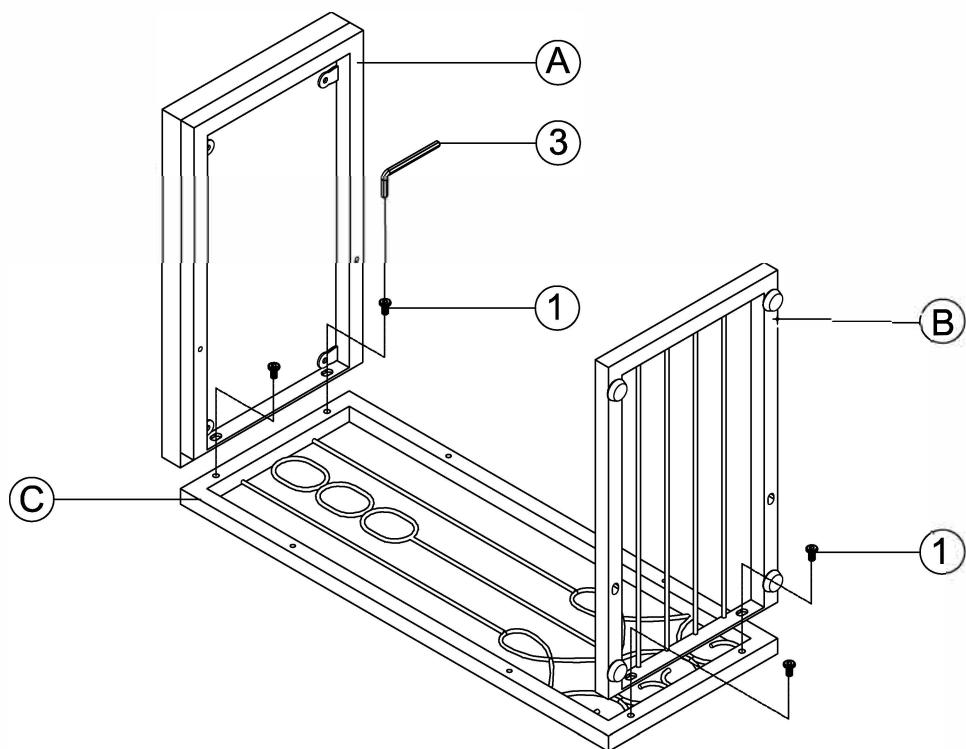

STEP 2

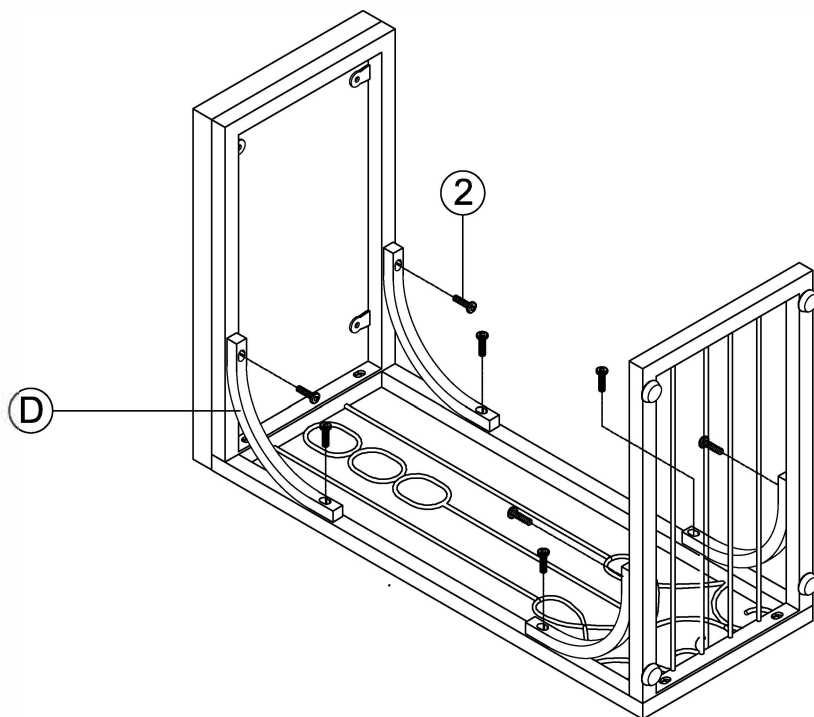

Product size:406WX229DX610H(mm)

Product size:16"WX9"D X24"H

