

# END TABLE-CHARGING STATION

## ASSEMBLY INSTRUCTIONS

Before assembling your End Table, please read through these instructions carefully. Familiarize yourself with the different parts.

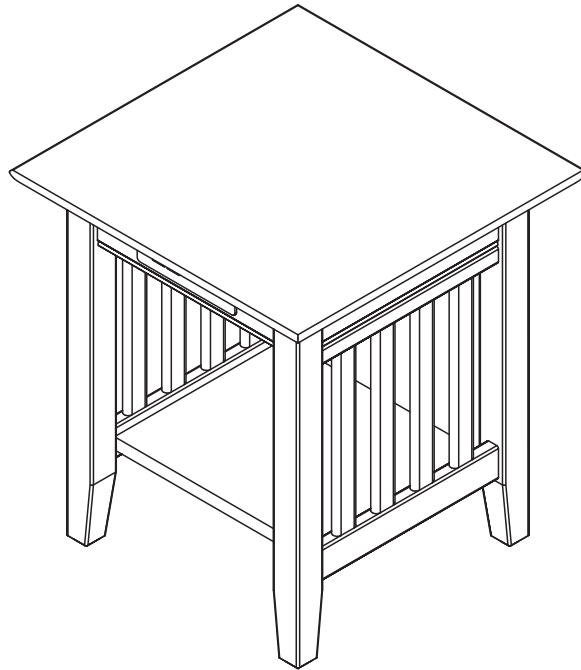

NOTE: WE INCLUDE SPARE HARDWARE IN CASE THE JCB, WOODEN DOWEL OR WOOD SCREW ARE DAMAGED DURING ASSEMBLY.

**A** Flat washer - 8 pcs  
Spare - 2 pcs

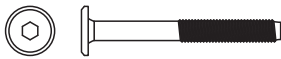

**B** JCB M8 - 4 pcs  
Spare - 1 pc

**C** Allen wrench - 1 pc



**D** Wooden Dowel 1/4" X 1 1/4" - 4 pcs  
Spare - 1 pc

**E** Wooden Dowel 3/8 X 1 1/4" - 4 pcs  
Spare - 1 pc

**F** Wood Screw - 8 pcs  
Spare - 2 pcs

## PARTS LIST

- 01** TOP PANEL 1 PC
- 02** LEG 4 PCS
- 03** SIDE PANEL 2 PCS
- 04** LOWER SHELF 1 PC

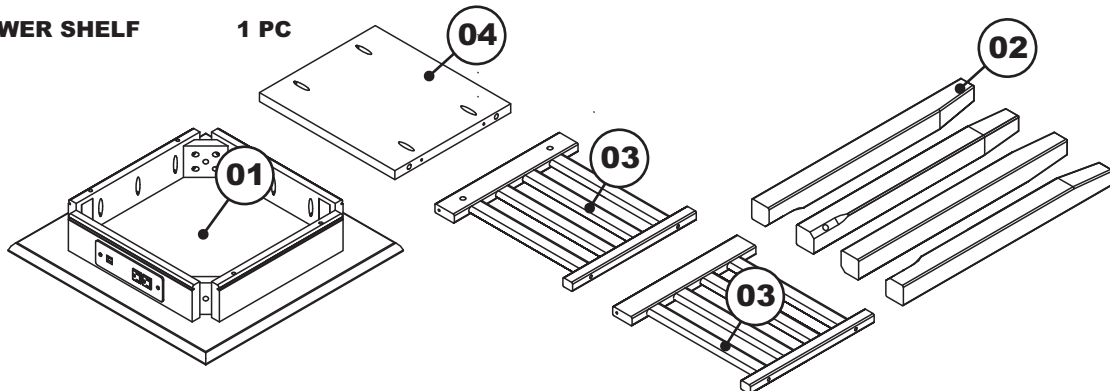

**STEP 1**

Attach the legs (02) to the top panel (01) as shown below using flat washers (A) and JCB (B), tighten with Allen wrench (C).

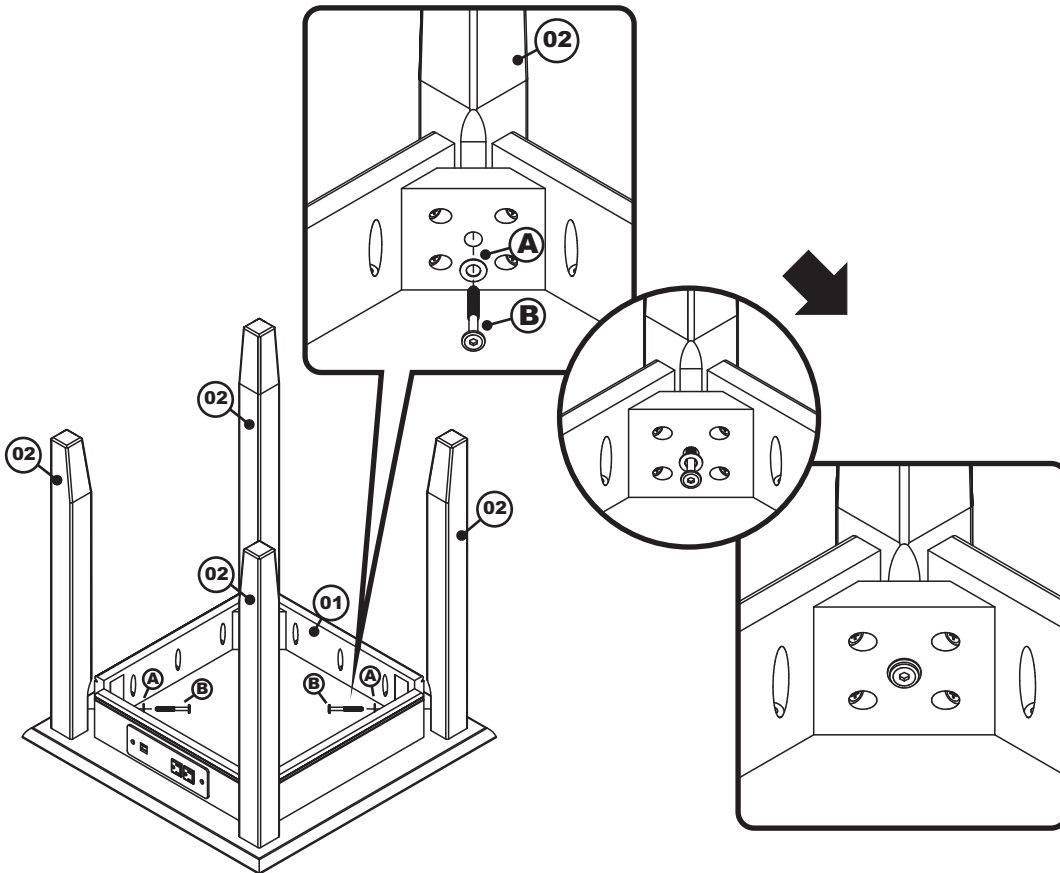
**STEP 2**

Install wooden dowels (D)(E) into the locator holes on (03)(04) as shown below.

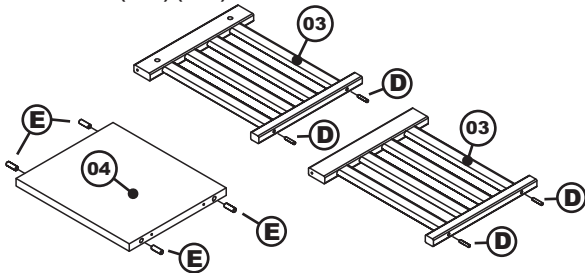
**STEP 3**

Attach first side panel (03) to end table aligning the dowels with the holes in the apron. Be sure the panel is centered before tightening the wood screw (F).

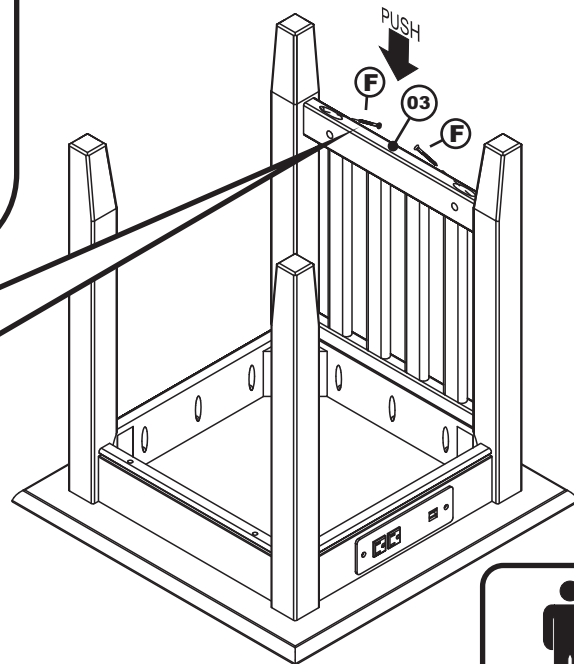

note : panel in center

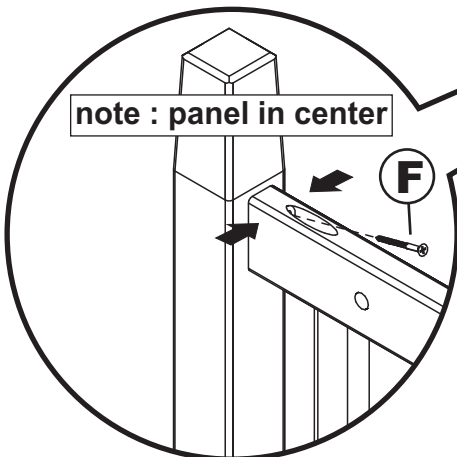

**STEP 4**

Attach second side panel (03) the same as the first but place the lower shelf (04) in position by aligning the wooden dowels with the holes in the side panel.

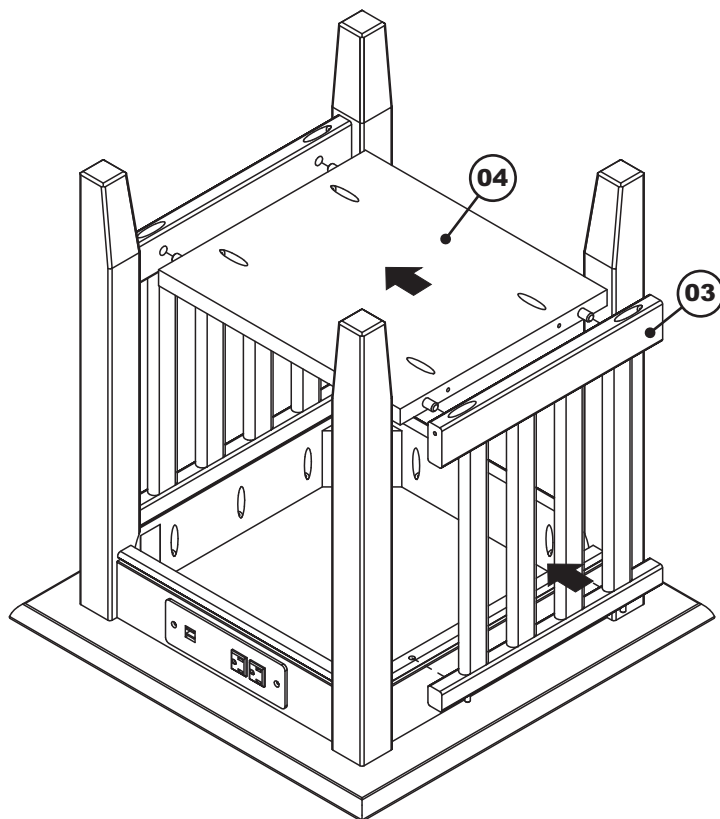
**STEP 5**

Apply pressure to eliminate any gap between the lower shelf and the side panel and fix in place using wood screw (F).

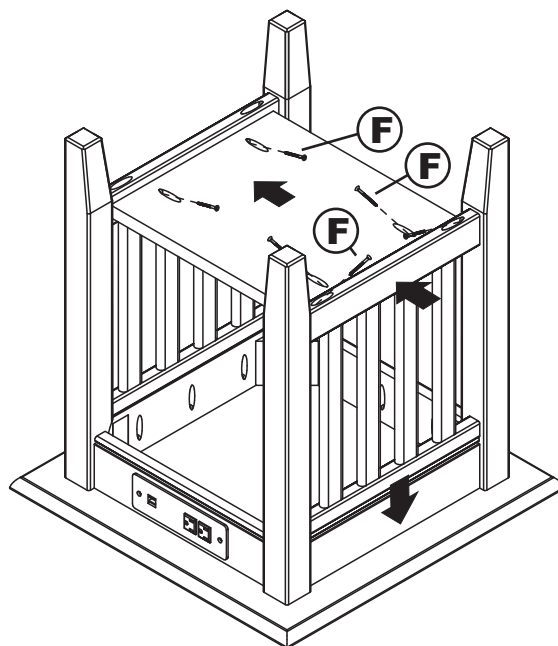

**Congratulations !**

Your end table charging station is now ready for use.

We recommend that you recheck that all screws are tight, and that all parts are secure before use and periodically to ensure lasting Safety.