

Assembly | Asambla | Assemblage

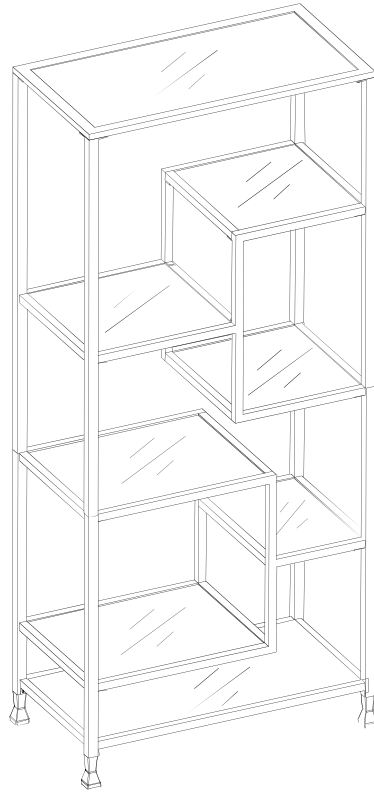

Assembly | Asambla | Assemblage

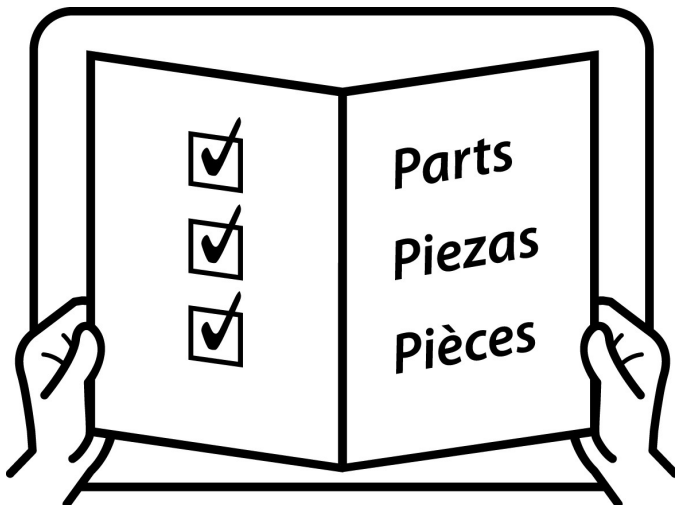
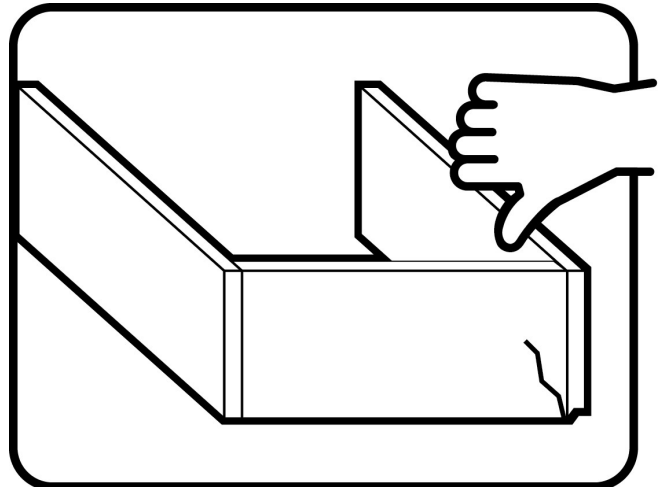
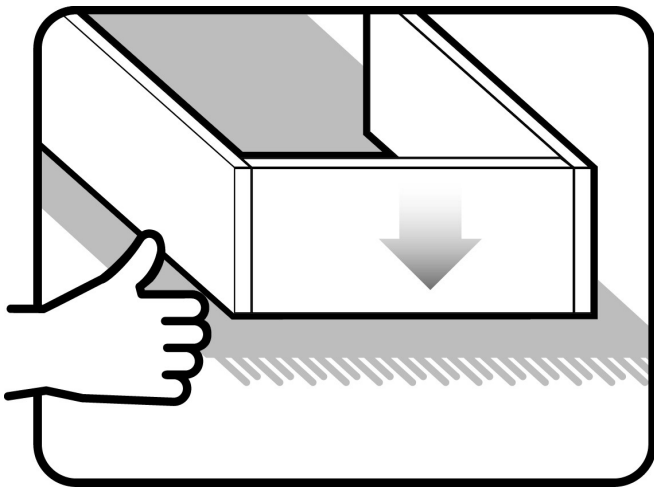
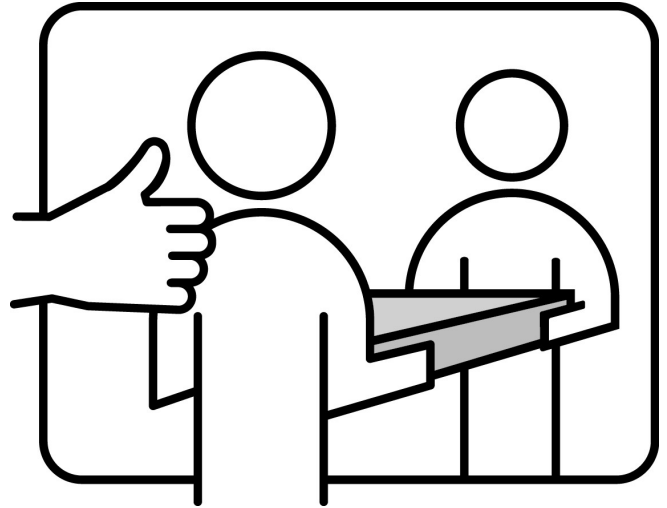
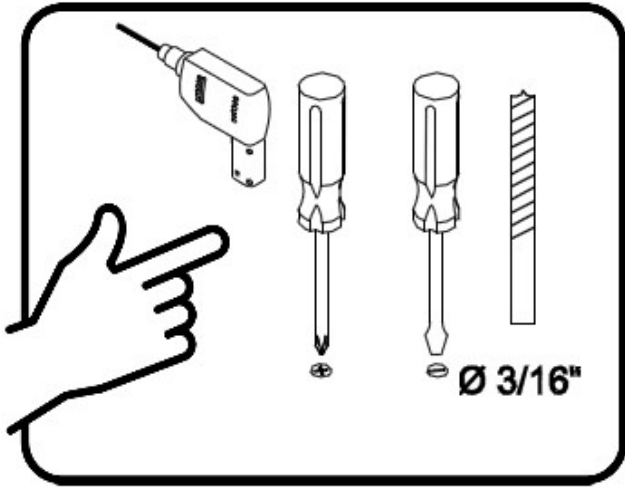

Assembly | Asamblea | Assemblage

Techniques | Técnicas | Techniques

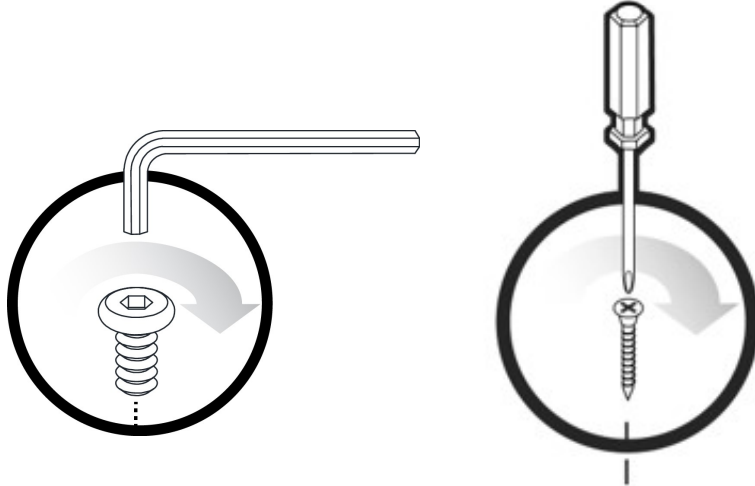

Care | Cuidado | Entretien

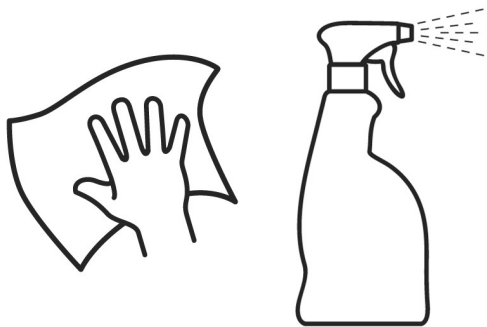

Safety | Seguridad | Sécurité



Note! | ¡Nota! | Remarque!





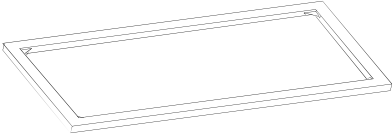
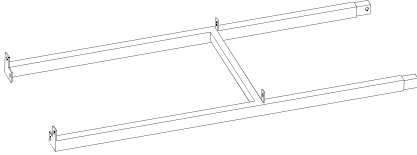
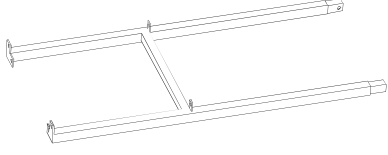
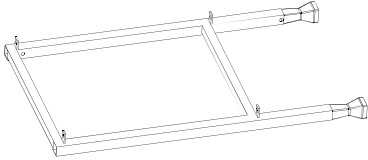
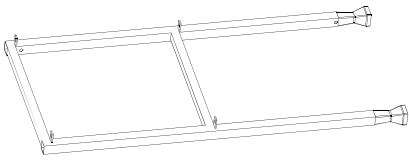
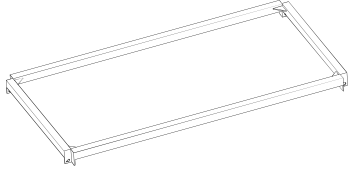
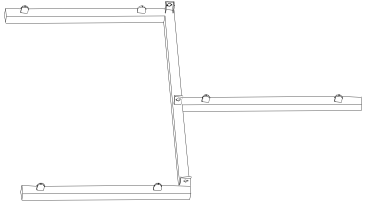
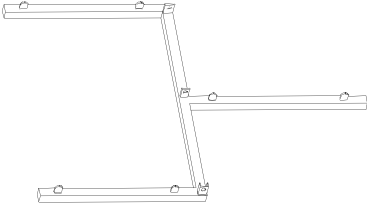
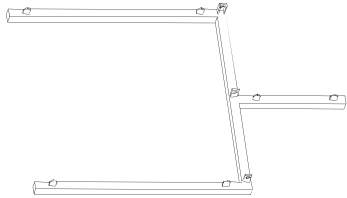
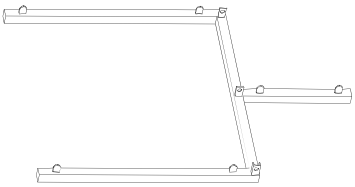
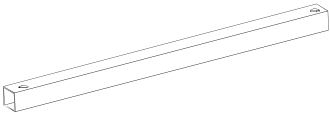
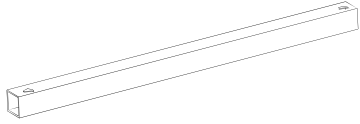

Assembly | Asambla | Assemblage

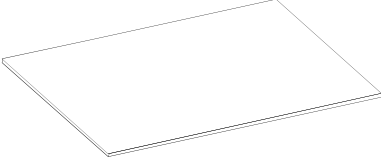
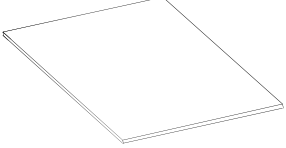
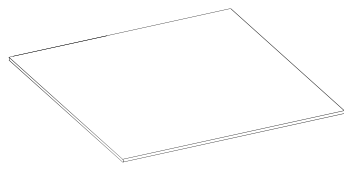
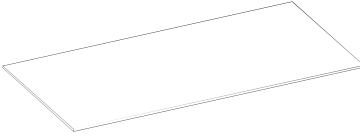
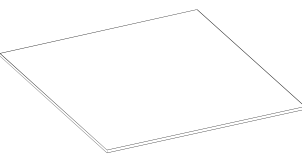
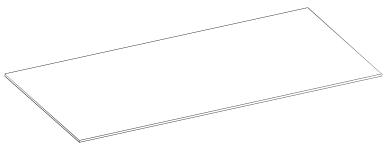
1 x1  Top Frame	2 x1  Side Panel 2	3 x1  Side Panel 3
4 x1  Side Panel 4	5 x1  Side Panel 5	6 x1  Shelf Frame
7 x1  Stretcher 7	8 x1  Stretcher 8	9 x1  Stretcher 9
10 x1  Stretcher 10	11 x2  Stretcher 11	12 x4  Stretcher 12

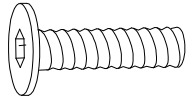
Assembly | Asambla | Assemblage

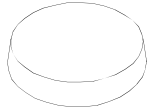
13  Glass Top	x1	14  Glass Shelf	x2	15  Glass Shelf	x1
16  Glass Shelf	x2	17  Glass Shelf	x1	18  Glass Shelf	x1

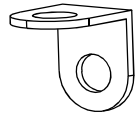
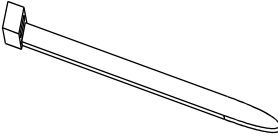
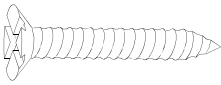
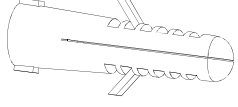

A  Bolt 1/4" x 1/2"	x40	B  Flat Washer	x40	C  Pad	x32	D  Allen Wrench	x1
E  L Bracket	x2	F  Plastic Strap	x2	G  Screw 5x38mm	x2	H  Wall Anchor	x2

Box A: 1,2,3,4,5,6,7,8,9,10,11,12, hardware
 Box B: 13,14,15,16,17,18

Assembly | Asamblea | Assemblage

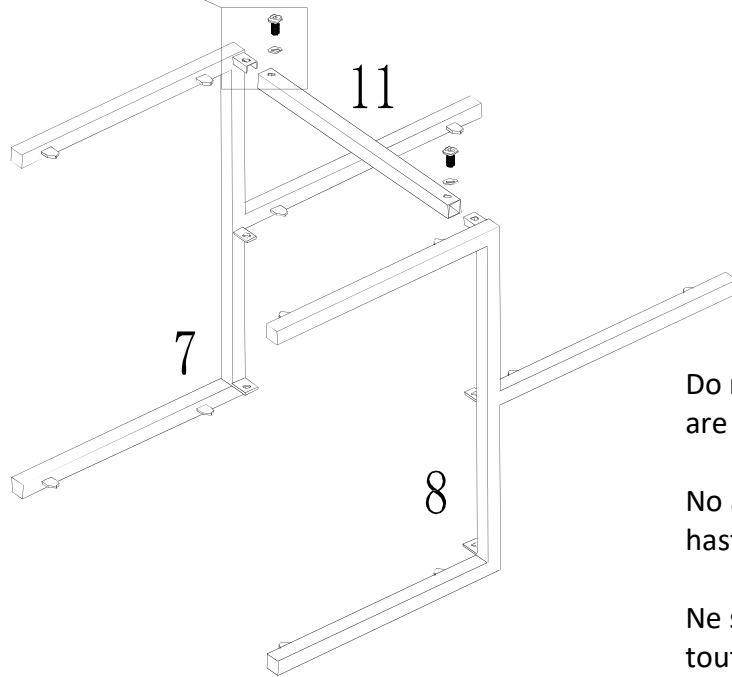
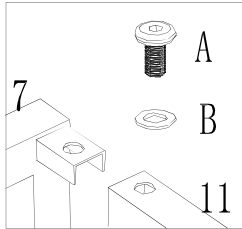
1

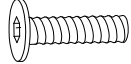

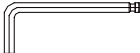
A		X 6
B		X 6
D		X 1

Do not fully tighten screws until all screws are in position.

No apriete completamente los tornillos hasta que estén en su posición.

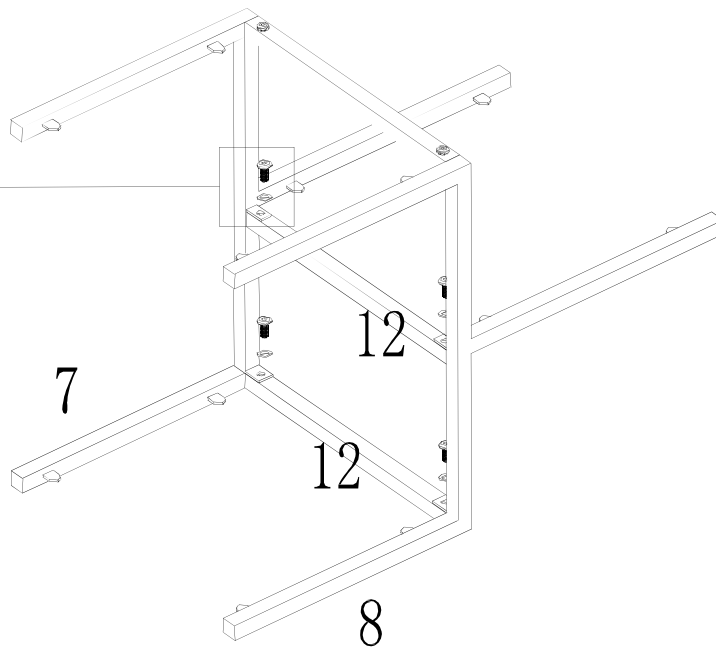
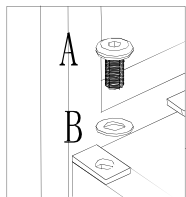

Ne serrez pas complètement les vis tant que toutes les vis ne sont pas en place.

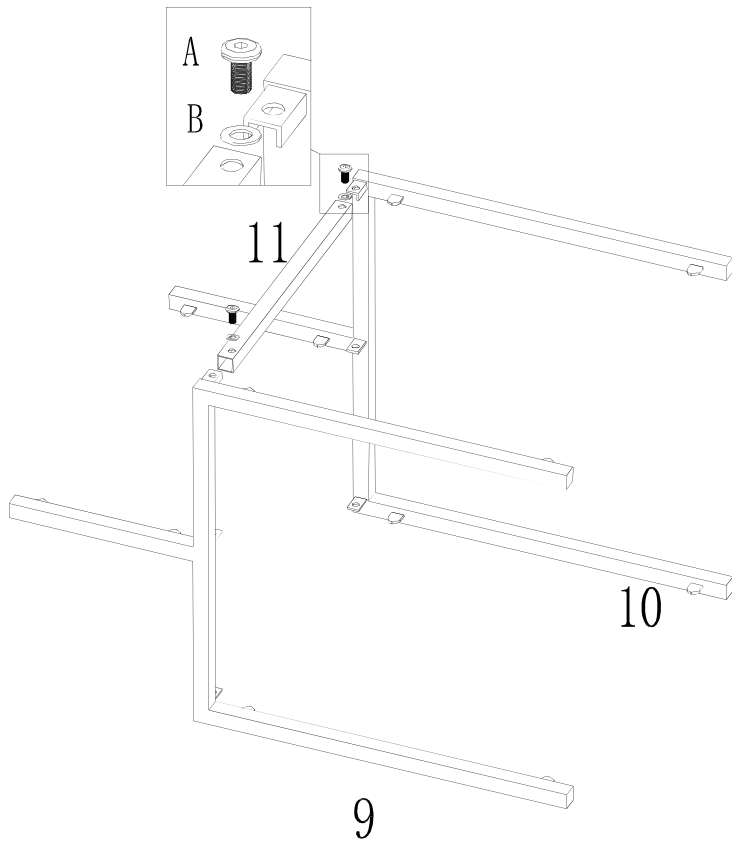

Assembly | Asambla | Assemblage

2

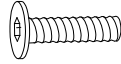

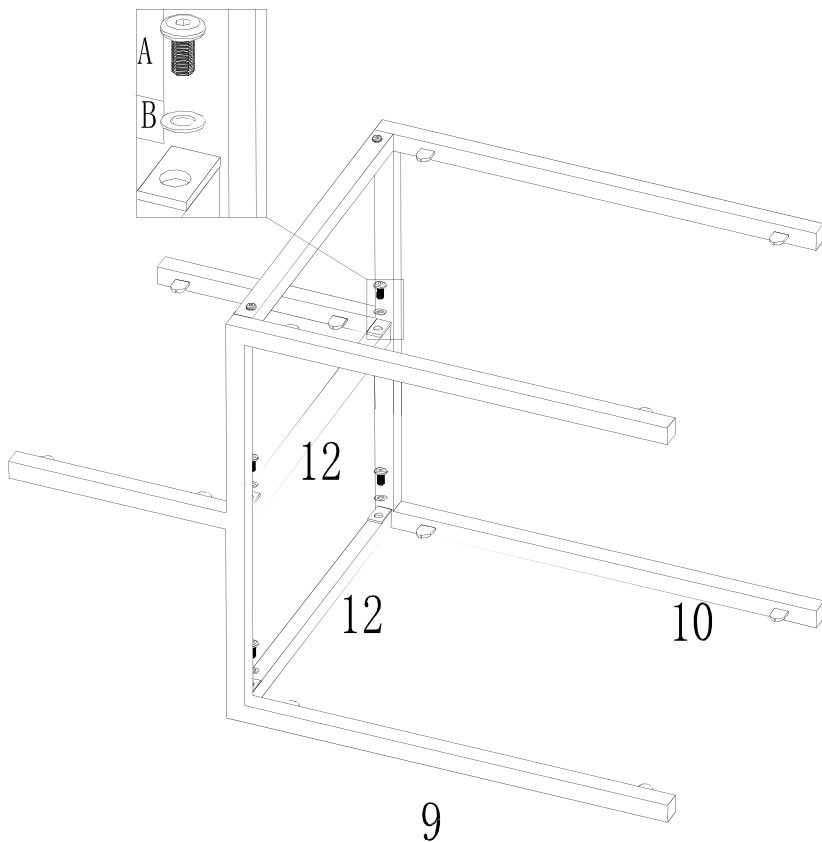

A		X 6
B		X 6
D		X 1

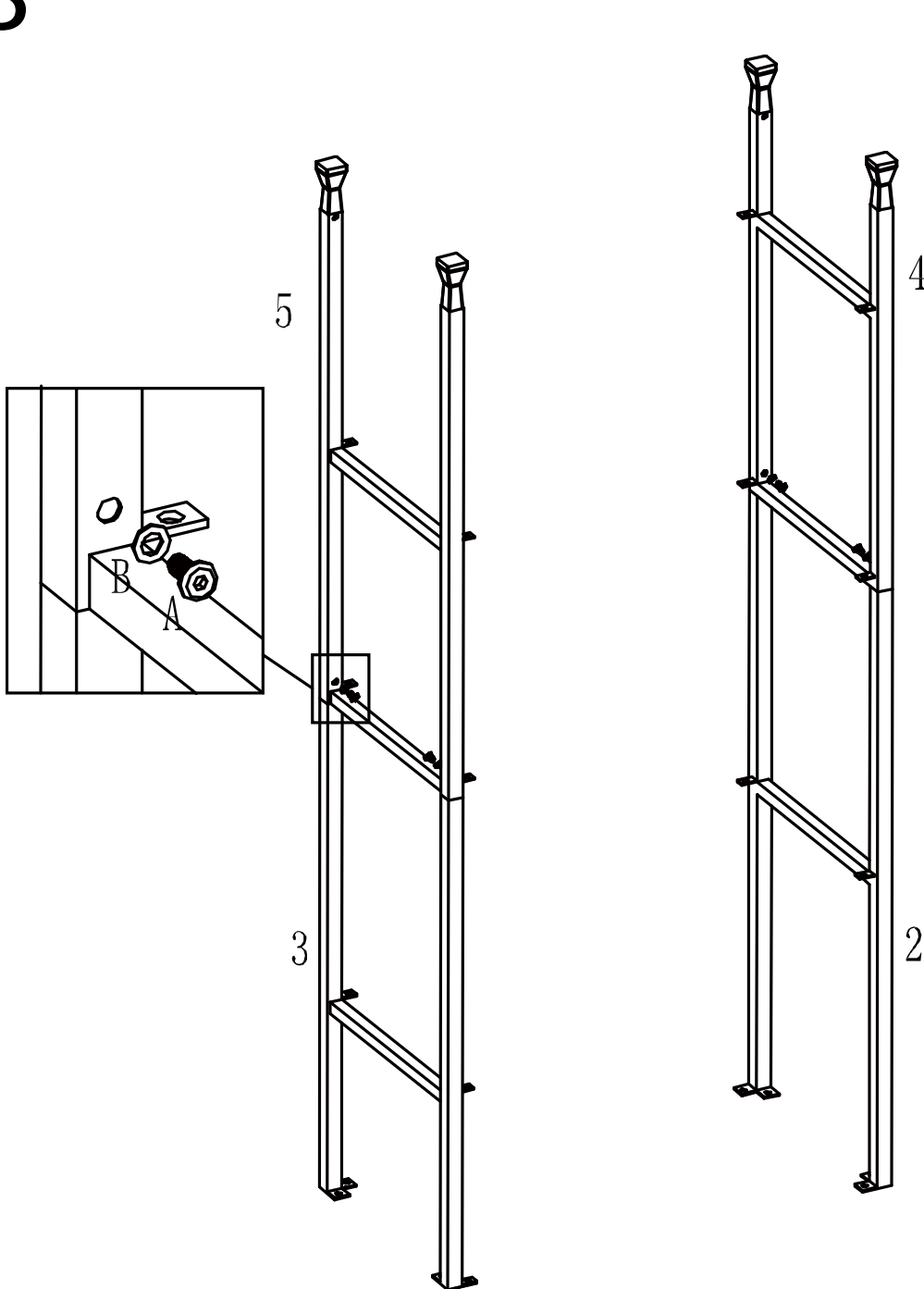

Assembly | Asambla | Assemblage

3

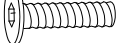



A		X 4
B		X 4
D		X 1

Assembly | Asambla | Assemblage

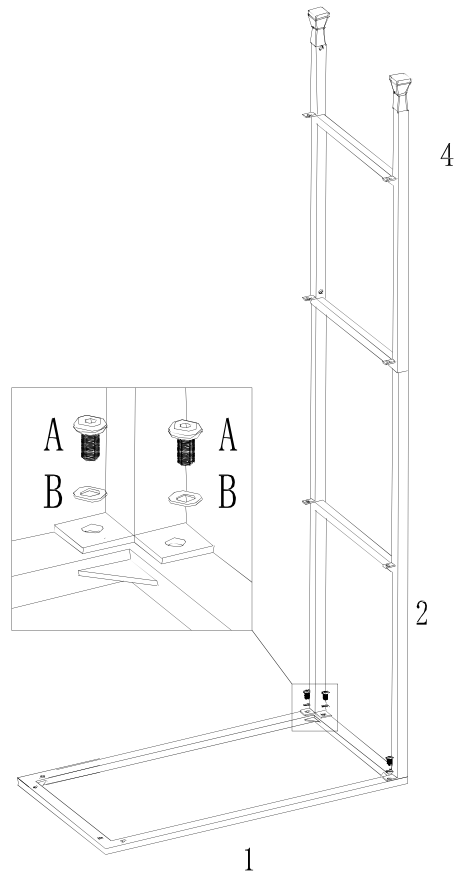

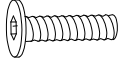
4

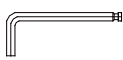

A		X 4
B		X 4
D		X 1

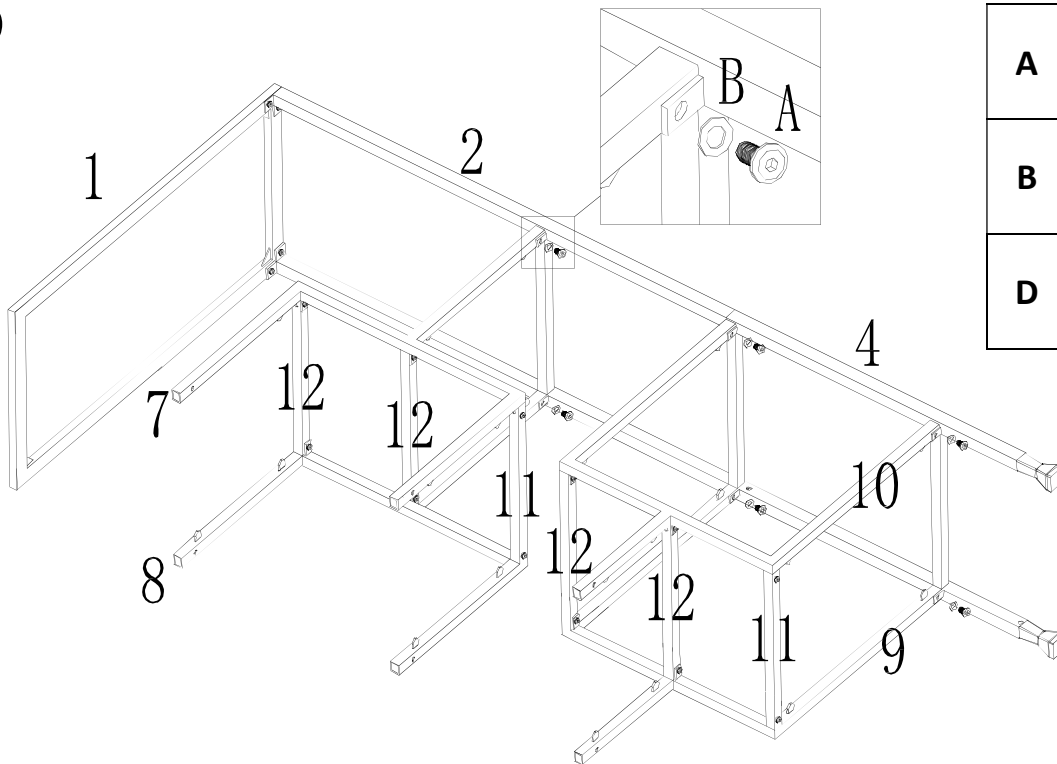
5

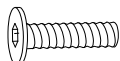



A		X 6
B		X 6
D		X 1

Assembly | Asamblea | Assemblage

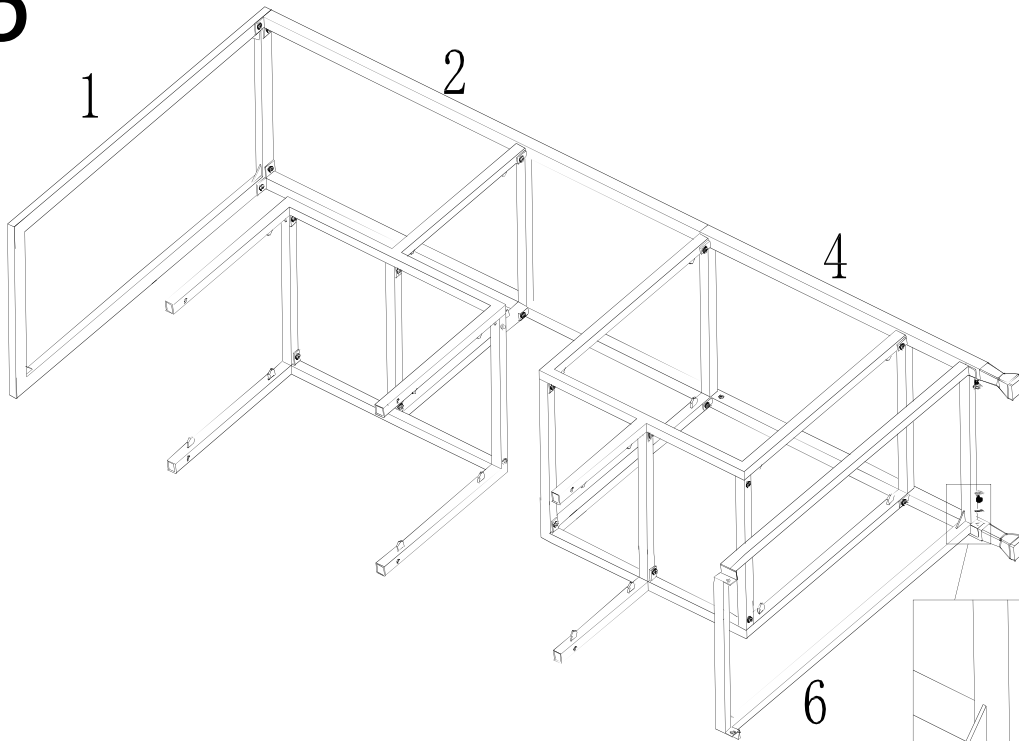
6

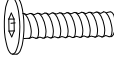



A		X 2
B		X 2
D		X 1

Tighten all screws
Apretar todos los tornillos
Serrez toutes les vis

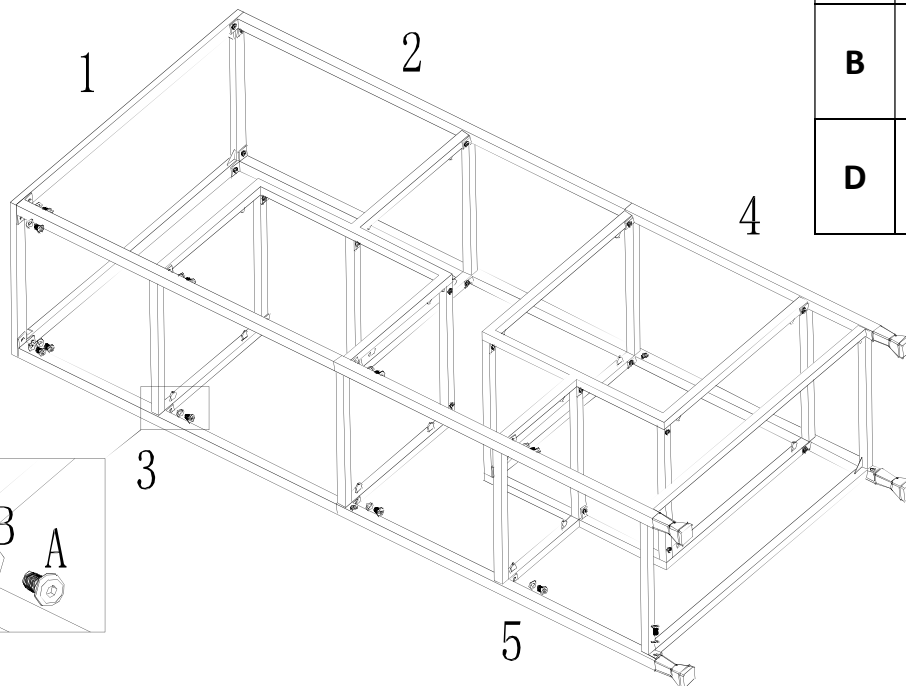

7

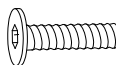

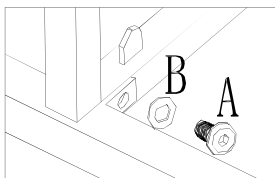

A		X 12
B		X 12
D		X 1

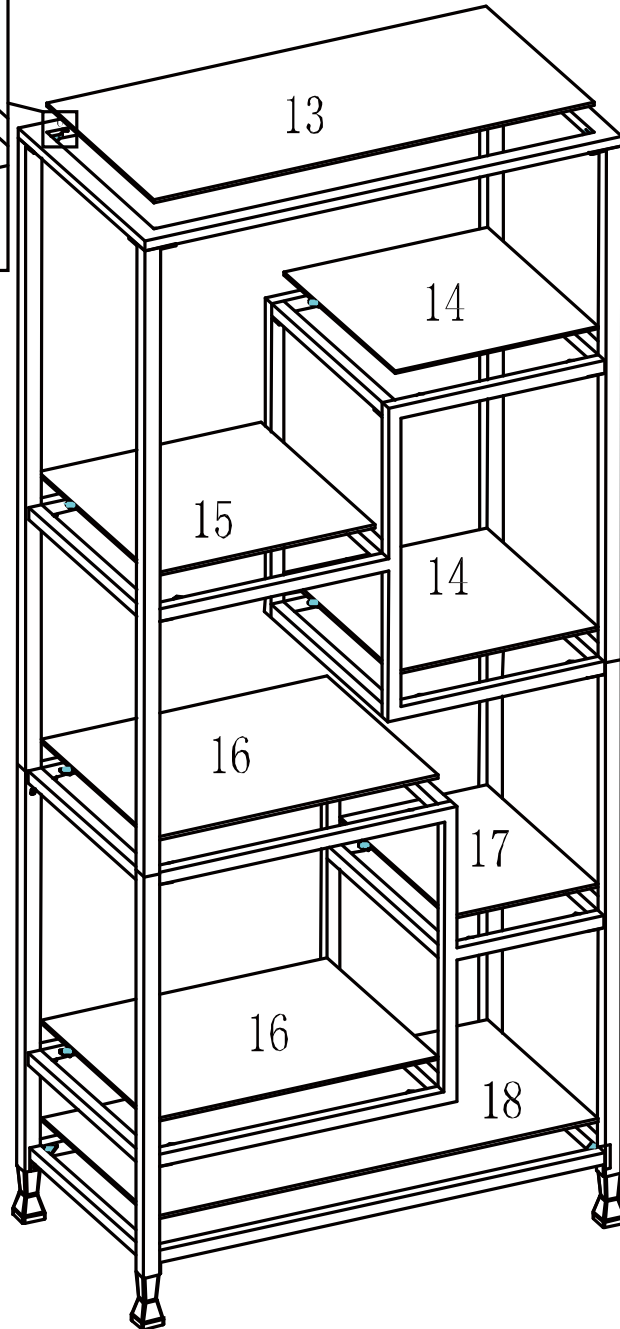
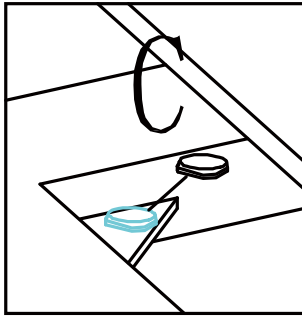

Assembly | Asambla | Assemblage

8



c		X 32
---	---	------

Assembly | Asambla | Assemblage

9

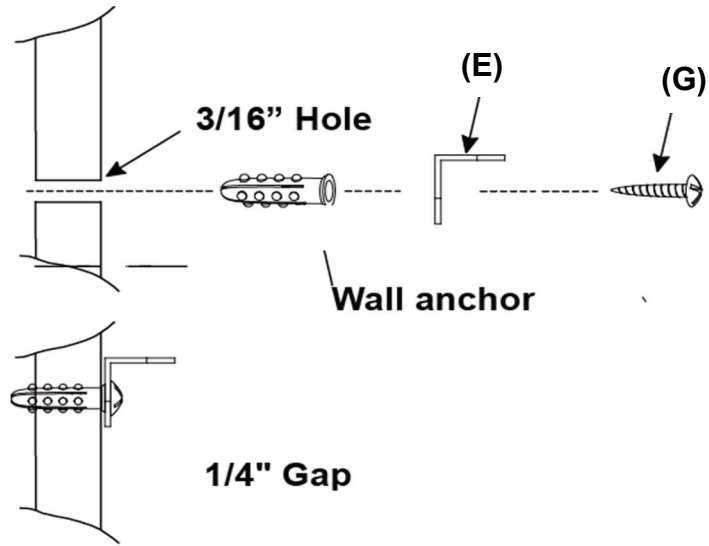

E		X 2
F		X 2
G		X 2
H		X 2

