

THKFVBV017

# INSTALLATION INSTRUCTIONS

# DIMENSIONS

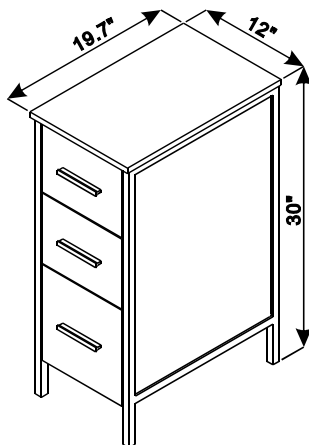





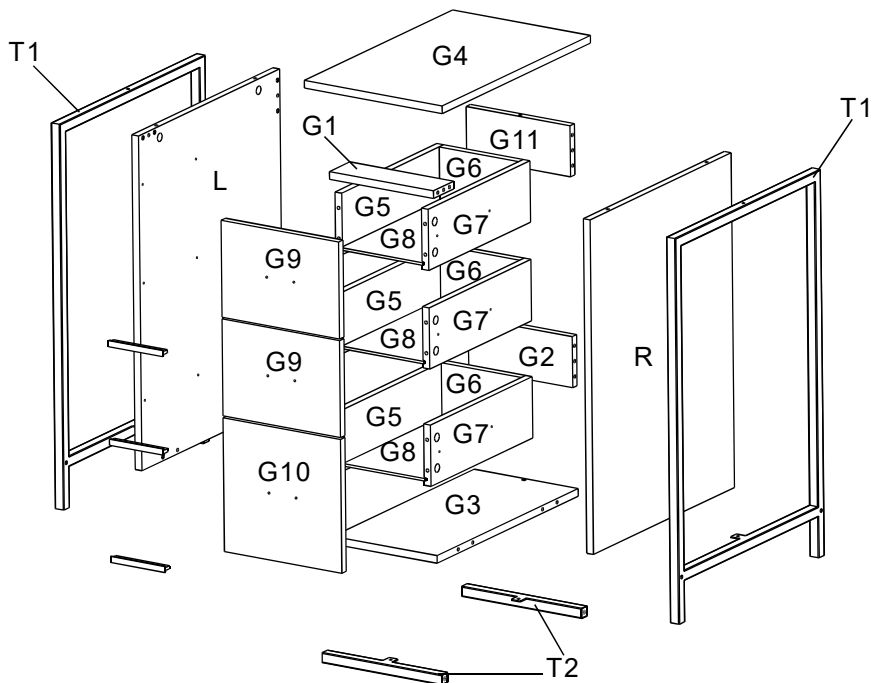











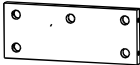
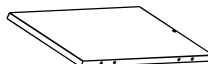

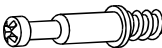
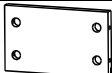

Unit:inch

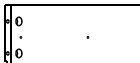
# ASSEMBLY DIAGRAM



# PARTS LIST

PARTS LIST			PARTS LIST		
NO.	DESCRIPTION	QTY			
T1		2	G8		3
T2		2	G9		2
L		1	G10		1
R		1	G11		1
G1		1	<b>HARDWARE LIST</b>		
G2		1	NO.	DESCRIPTION	QTY
G3		1	A		10
G4		1	B		45
G5		3	C		45
G6		3	D		45
G7		3	E	 ST4.2X16	28
			F	 M4X18	6
			G		3
			H	 ST4.2X30	4
			I	 M6X30	4
			J		6

CAUTION: Please confirm the parts list before installtion.

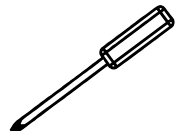

# PARTS LIST

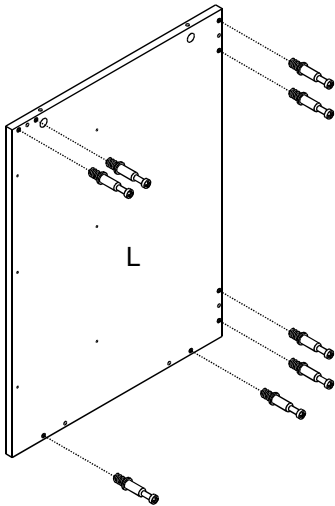

# INSTALLATIONS

## STEP 1





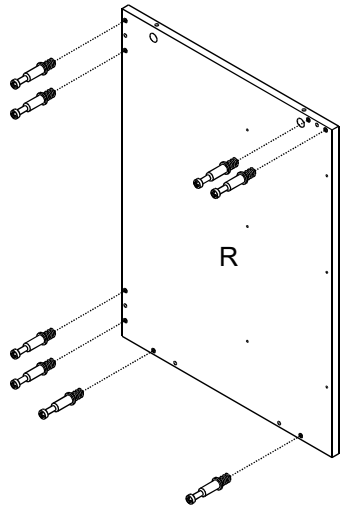



HARDWARE LIST	
C  16PCS	

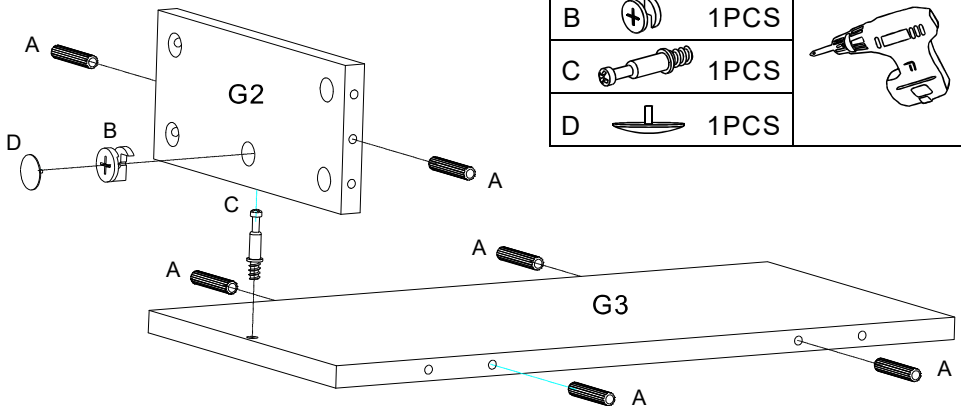

- Insert the cam screw into the shelves above.

## STEP 2



HARDWARE LIST	
A  6PCS	
B  1PCS	
C  1PCS	
D  1PCS	

- Insert the wooden dowel pins and cam screw into the shelves above. then tighten the cam lock.

## STEP 3

### HARDWARE LIST

A  4PCS

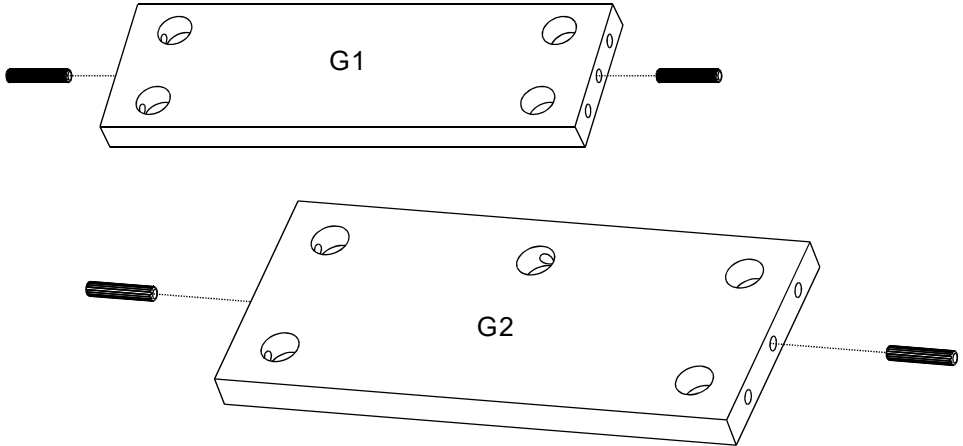

- Insert the wooden dowel pins into the shelves above.

## STEP 4

### HARDWARE LIST

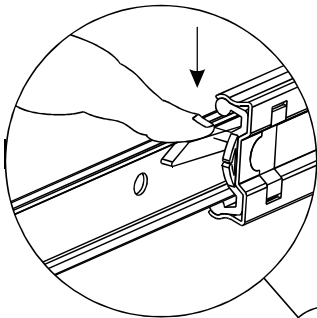

J  6PCS

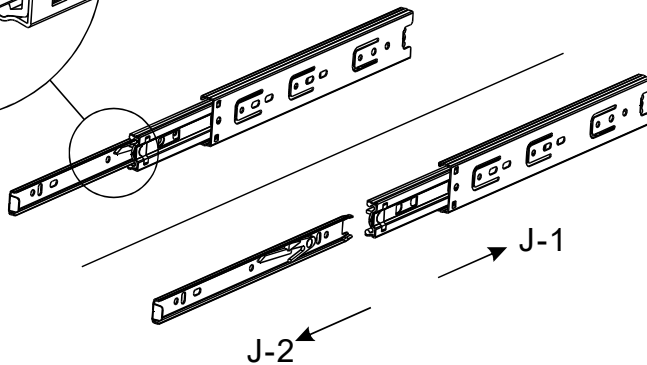

- Press the button and extend the slide slowly. Then separate it with the release latch. Repeat these steps for the other slides.



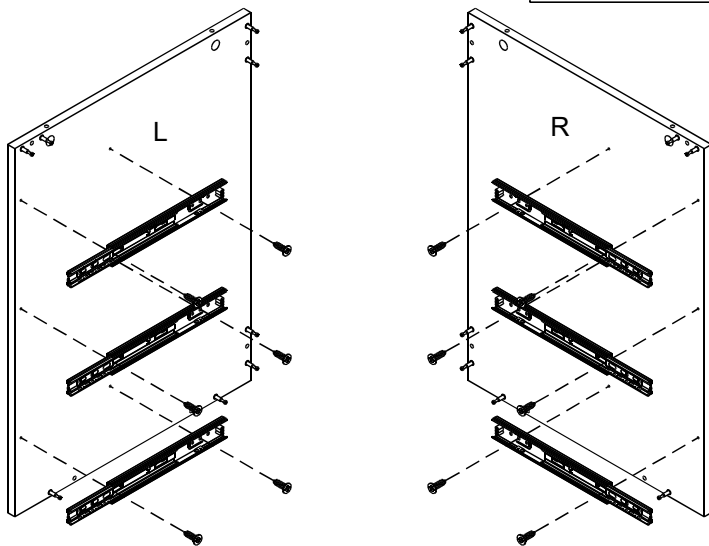

# STEP 5

HARDWARE LIST		
E	 12PCS	
J-1	 6PCS	





- Insert the screws to connect the slides (J-1) to the shelves.

# STEP 6

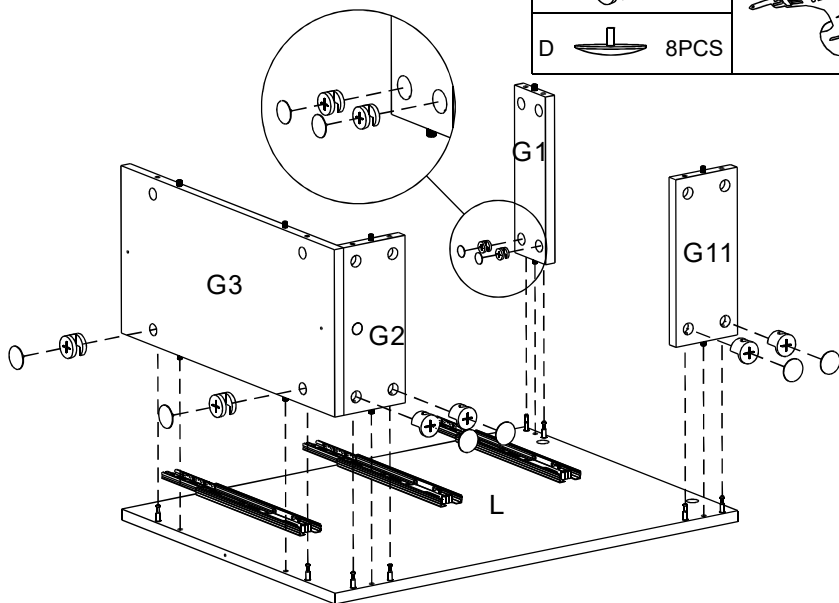
HARDWARE LIST		
B	 8PCS	
D	 8PCS	



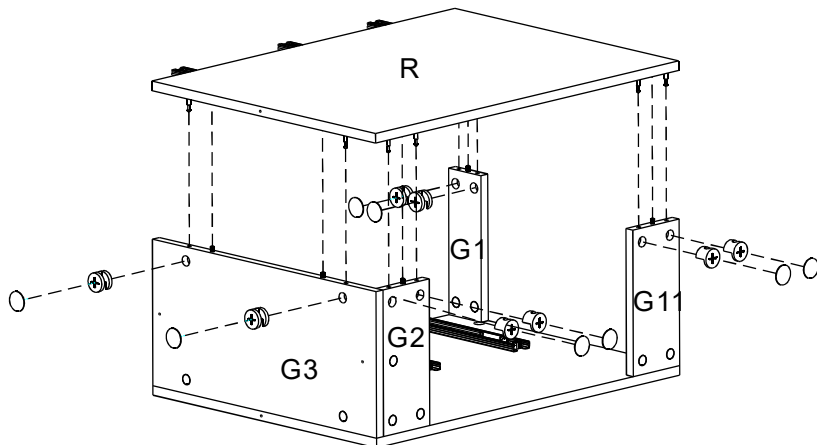

## STEP 7

HARDWARE LIST			
B		8PCS	
D		8PCS	



- Insert shelves G1,G2 and G3 downwards to their corresponding positions, then tighten the cam lock.



## STEP 8

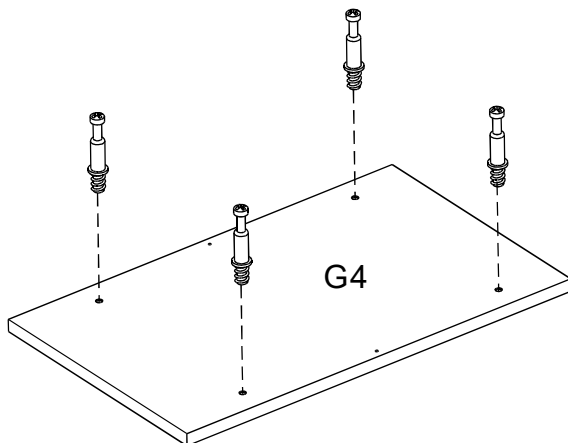

HARDWARE LIST			
C		4PCS	



- Insert the cam screw into the shelves above.

# STEP 9

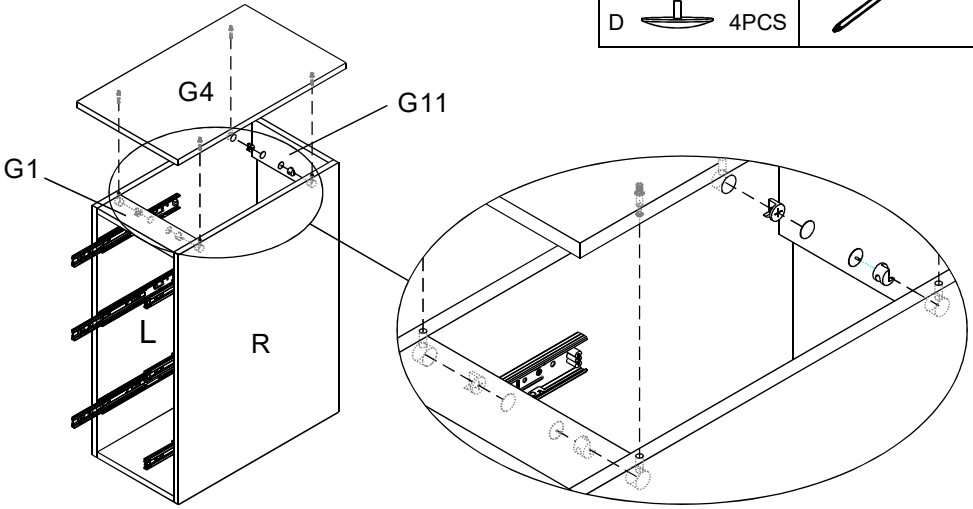

HARDWARE LIST		
B		4PCS
D		4PCS





- Insert shelves G4 to their corresponding positions and tighten the cam lock.

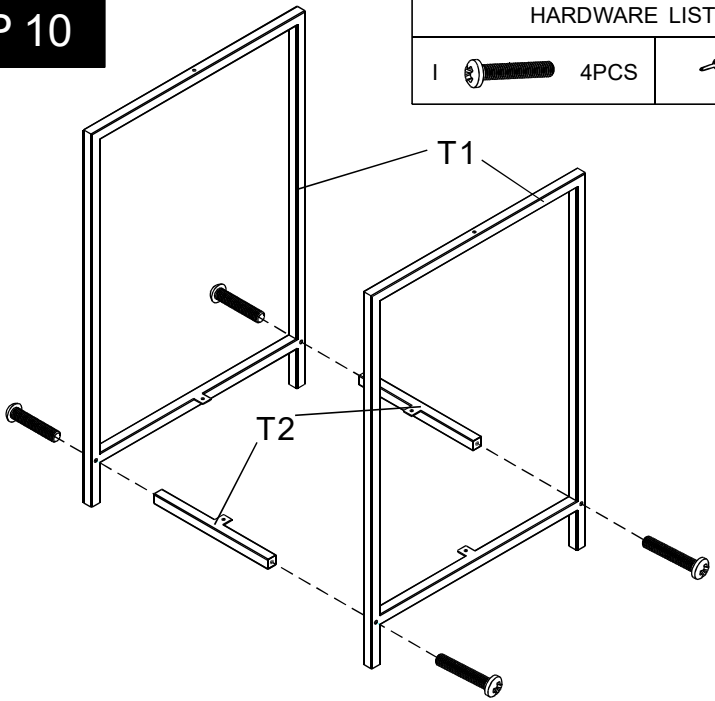

# STEP 10

HARDWARE LIST		
I		4PCS





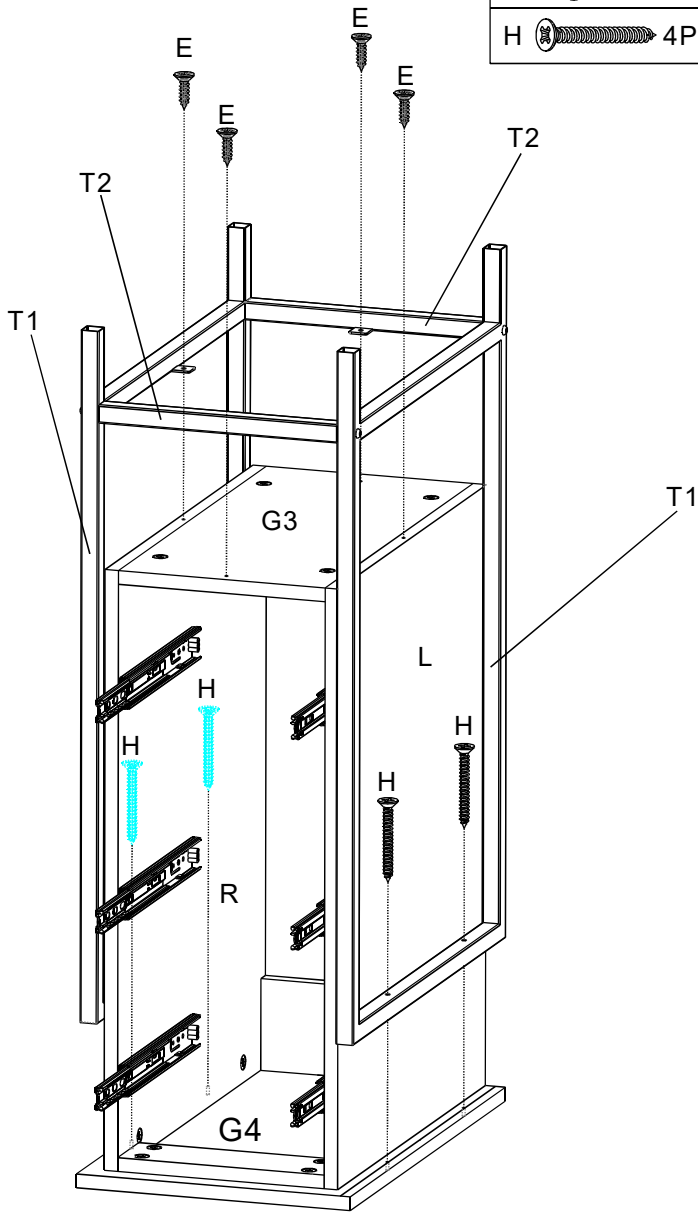

# STEP 11

HARDWARE LIST		
E		4PCS
H		4PCS

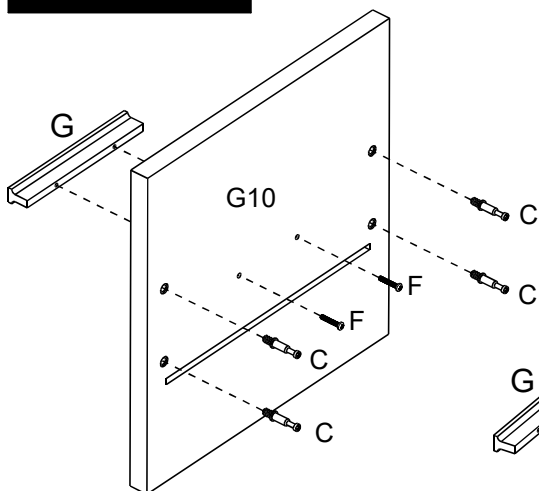

## STEP 12



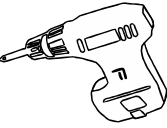
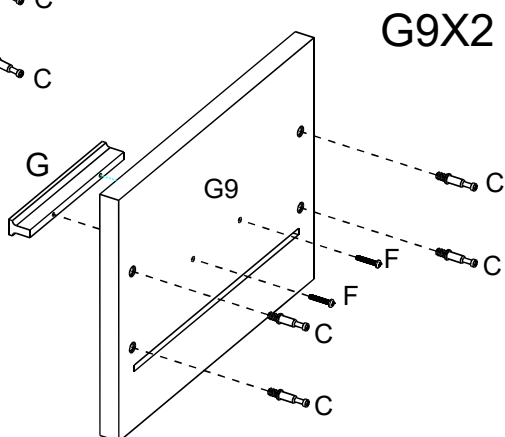

HARDWARE LIST	
C	 12PCS
F	 6PCS
G	 3PCS



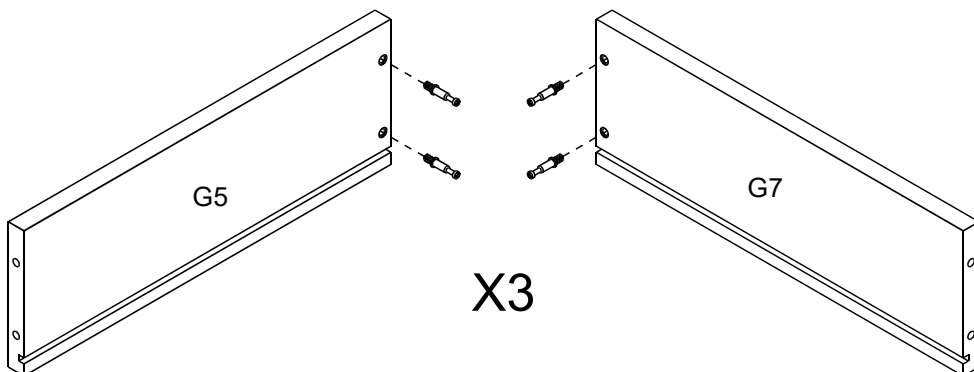

- Insert the cam screw and into the shelves above, and secure the handle and drawer plate G1 or G2 with hascrews.

## STEP 13



HARDWARE LIST	
C	 12PCS



- Insert the cam screw into the shelves above.

## STEP 14

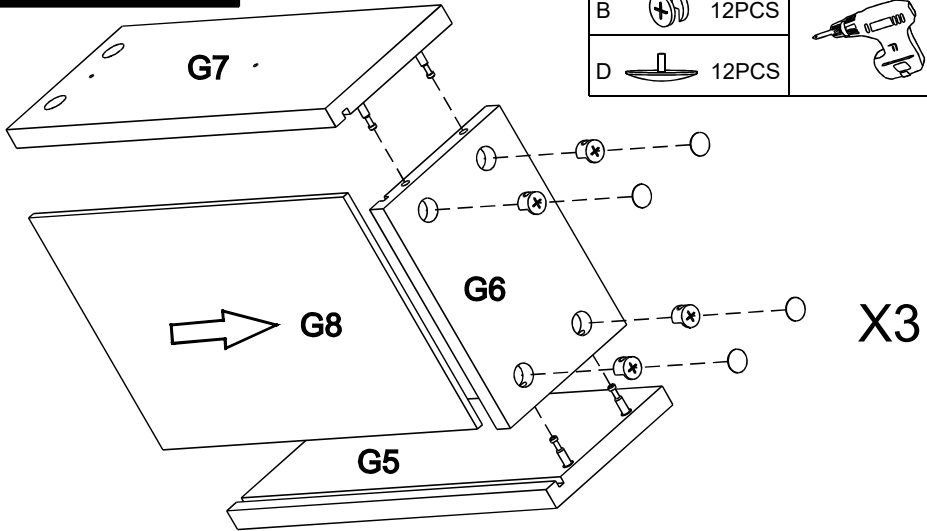

- Insert shelves G5,G6 and G7 to their corresponding positions and tighten the cam lock. Then insert the drawer bottom G8 along the groove.

## STEP 15

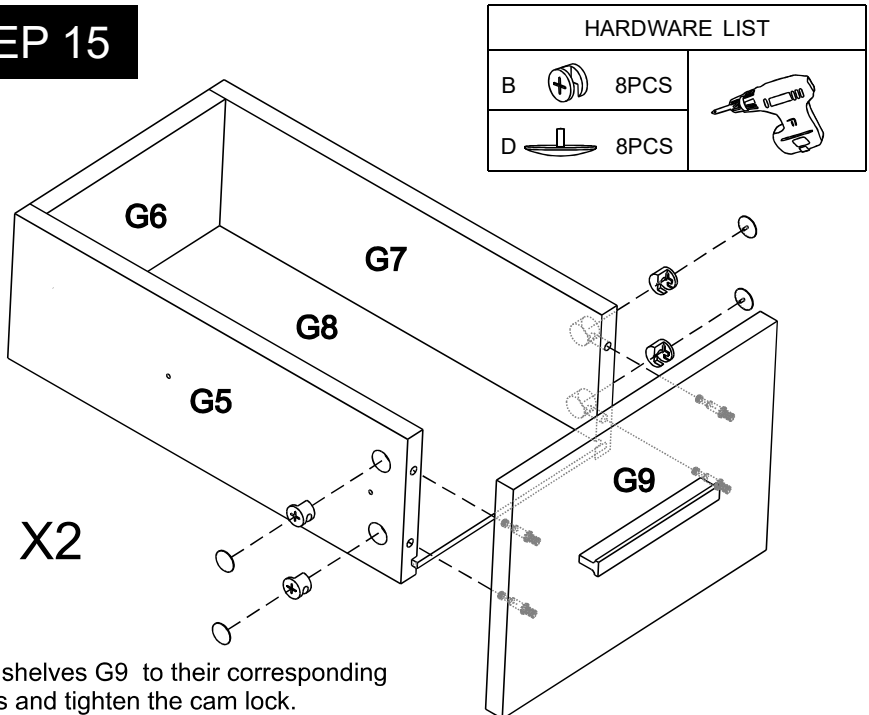

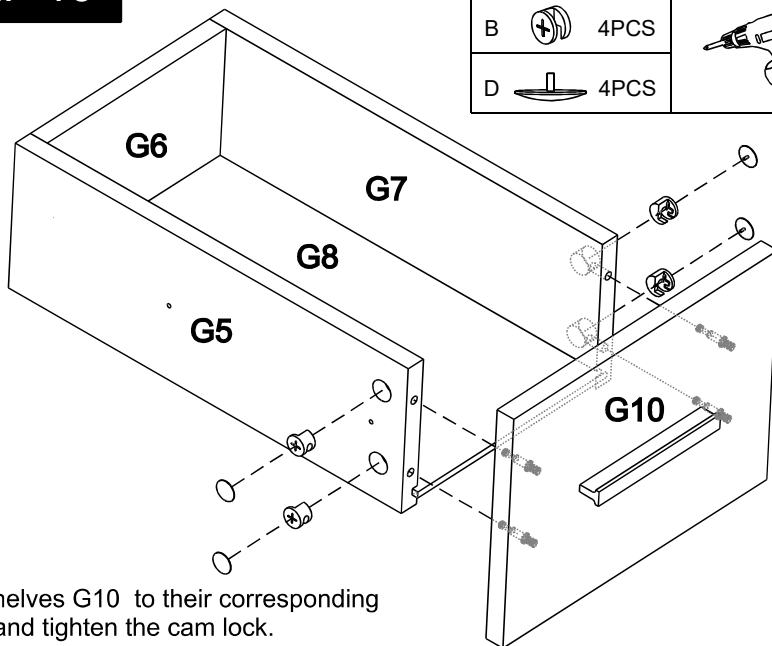

- Insert shelves G9 to their corresponding positions and tighten the cam lock.

## STEP 16



- Insert shelves G10 to their corresponding positions and tighten the cam lock.

## STEP 17

HARDWARE LIST		
E		12PCS
J-2		6PCS

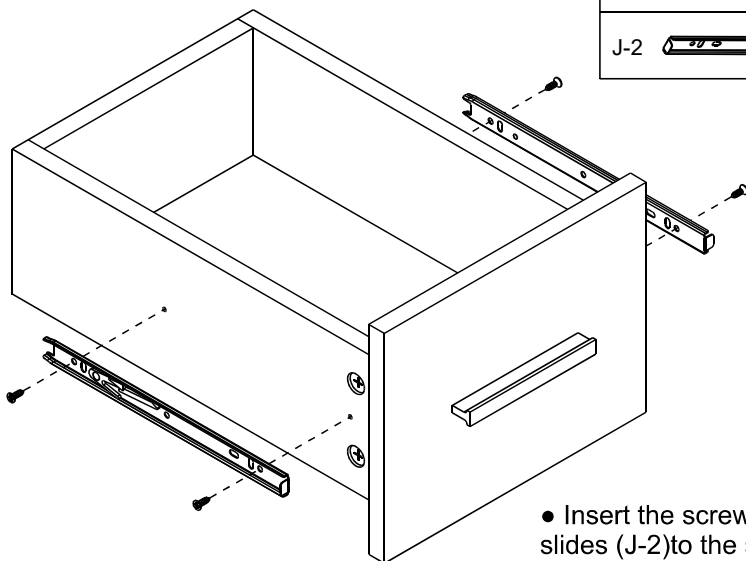

- Insert the screws to connect the slides (J-2) to the shelves.

## STEP 18

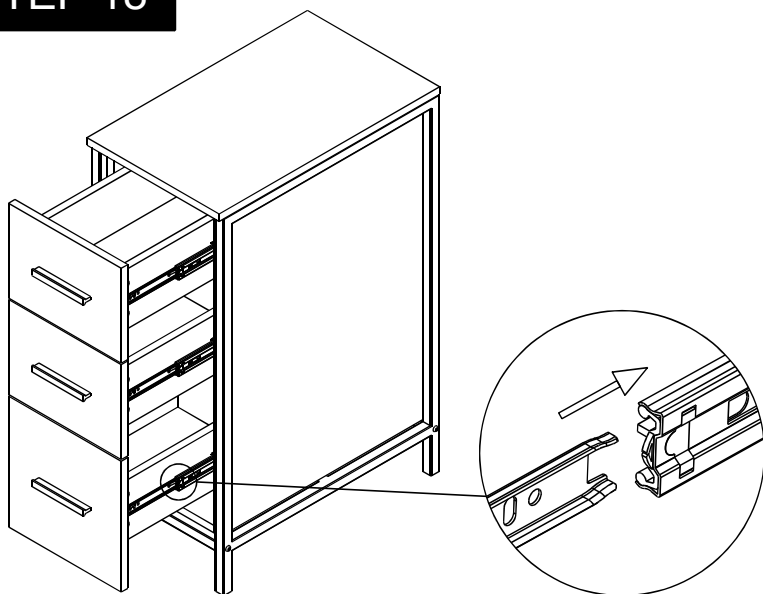

## STEP 19

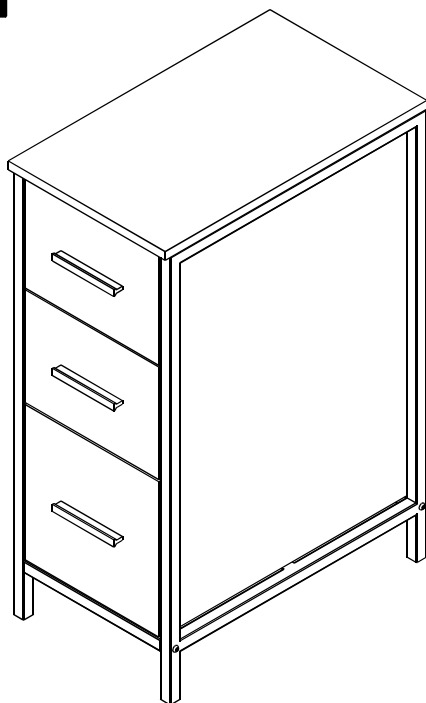



## FEEDBACK ★★★★★

Thank you very much for purchasing from us.

We have always been trying to provide the best service and reliable products for every customer.

We sincerely hope you will be satisfied with our products and leave us FIVE STARS and POSITIVE feedback/review in our page.

However, accident may happen sometimes, please contact us to resolve any issue before leaving a negative feedback.

Many thanks and welcome to our shop again!

Contact number: (323) 393-8260

E-mail: [service@eclifeusa.com](mailto:service@eclifeusa.com)