

## STEP 2

Tighten Top Cap (2) to Panel (A), as shown.

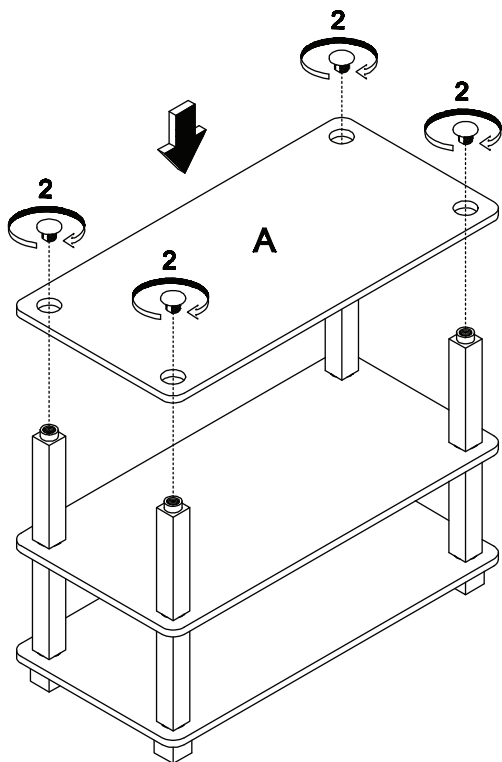

## Recommended Maximum Weight

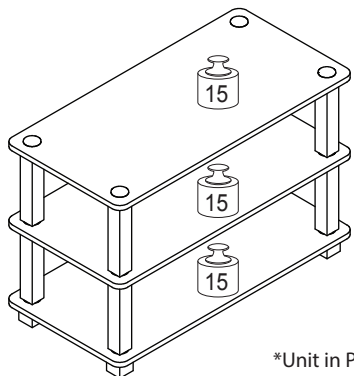

\*Unit in Pound(lbs)

### **WARNING:**

>This unit has been designed to support the maximum loads shown. Exceeding these load limits could cause sagging, instability, product collapse, and/or serious injury.

>DO NOT allow children to climb on unit.

>Put heavier items on lower shelves.

## **Assembly Instruction**

Turn-S-Tube 3-Tier Shoe Rack

00:10

Approx. 10 minutes





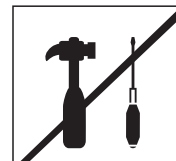

Recomm. 1 Person

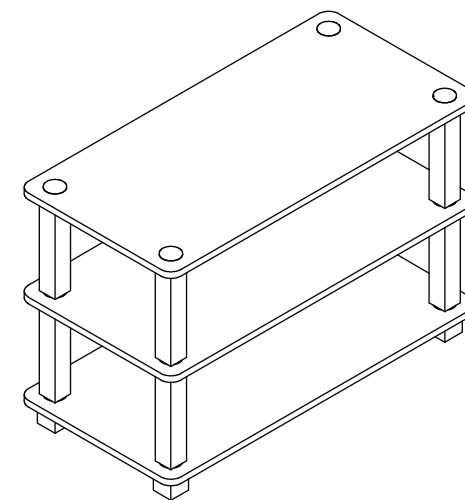

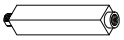
No Tools Required



No	Hardware List	Qty
1	Square Pole 	8pcs
2	Top Cap 	4pcs
3	Square Leg 	4pcs

No	Parts List	Qty
A	Shelf Panel 	3pcs

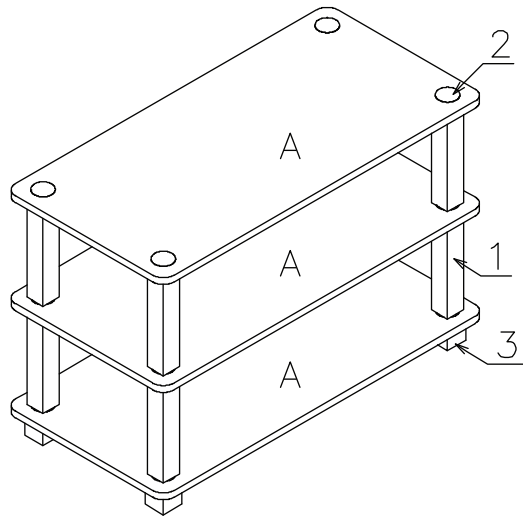

**USEFUL HINTS BEFORE YOU START:**

1. Read each step carefully before starting.
2. It is important that each step is performed in correct order to avoid difficulties.
3. Identify, sort and count the parts before assembly.
4. Assemble your furniture on packaging cardboard to prevent scratch or damage.
5. Clean the product with mild cleanser using soft damped cloth. Do not use harsh or abrasive cleanser.
6. Using incompatible hardware might cause damage to product.

**STEP 1**

Tighten Square Pole(1) & Square Leg(3) to Panel (A), as shown.

