

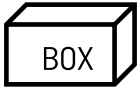

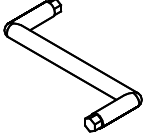





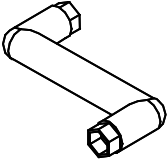
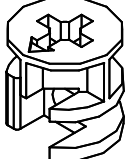
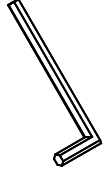
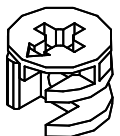
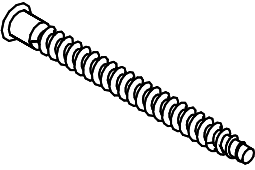
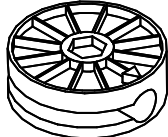
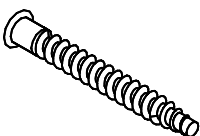
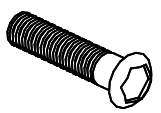
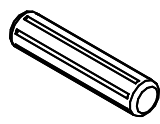
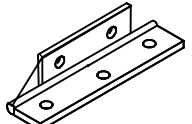
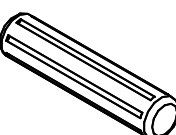
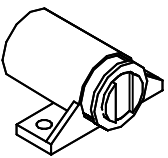

NR ELEMENTU ITEM NUMER ARTIKELNUMMER ПУНКТ НОМЕРА		IND 4010784 / 4015207	ILOŚĆ QUANTITY ANZAHL НОМЕРА	WYMIARY [mm] DIMENSIONS [mm] ABMESSUNGEN [mm] РАЗМЕРЫ [mm]		
7	1/10	2103387 / 2153576	2	315	150	38
16	1/10	2103301 / 2153534	5	316	240	22
5	1/10	2103402 / 2153598	1	1315	181	38
8	1/10	2103377 / 2153570	2	250	150	22
24	1/10	2103380 / 2153572	1	1315	181	38
13	2/10	2103572 / 2153054	2	1760	676	3
23	2/10	2206937 / 2206939	1	1596	460	16
22	2/10	2206936 / 2206938	1	1601	590	22
25	3/10	2103385 / 2153574	1	1315	157	38
9	3/10	2103393 / 2153582	1	120	1315	38
11	3/10	2109872 / 2153058	1	1315	350	22
10	3/10	2103422 / 2153612	1	1315	350	22
17	4/10	2103429 / 2153622	1	1601	300	22
20	4/10	2103412 / 2153608	1	1601	283	22
19	4/10	2103410 / 2153606	1	1601	300	22
18	4/10	2103416 / 2153610	1	1601	300	22
21	5/10	2103428 / 2153620	1	1601	262	16
14	5/10	2103427 / 2153618	1	1601	1022	16
6	6/10	2103399 / 2153592	2	120	2042	38
4A	6/10	2109960 / 2153064	1	350	2042	22
2A	7/10	2103400 / 2153594	1	181	2042	38
4B	7/10	2109964 / 2153066	1	350	2042	22
3A/3B	8/10	2103403 / 2153600	2	157	2042	38
2B	8/10	2103401 / 2153596	1	181	2042	38
1B	9/10	2109874 / 2153060	1	2058	181	38
15B	9/10	2103397 / 2153588	1	2058	300	38
1A	10/10	2109876 / 2153062	1	2058	181	38
15A	10/10	2103396 / 2153586	1	2058	300	38
X	2/10	1101429 / 1101429	1	1717	22	-

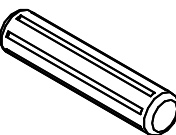
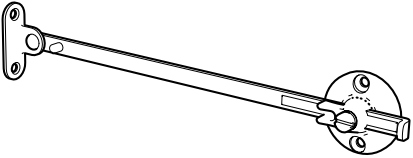
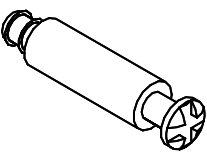
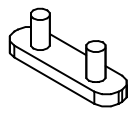
1000806	4 "Z" x 3		1006091	C16 x 45	
1000252	5 "Z" x 1		1005990	D4 x 27 (15x22)	
1000244	6 "L" x 1		1005735	D3 x 18 (15x16)	
1005962	A2 x 40 (7x70)		1103992	D12 x 16	
1005876	A3 x 14 (7x50)		1005395	E4 x 8 (M6x36)	
1005857	B14 x 9 (8x36)		1124582	F62 x 3	
1005863	B17 x 12 (10x36)		1004817	I91 x 2	 
1005669	B18 x 4 (10x55)		1128380	K5 x 2	
1103994	C1 x 16		1000868 1003272	M x 4	

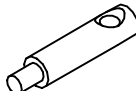
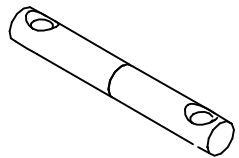
1005368	R18 x 15 (3x30)		1109473	R52 x 22	
1008908	R19 x 42 (3x20)		1107571	R53 x 6	
1006024	R20 x 8 (4x35)		1109475	R54 x 8	
1006012	R21 x 4 (3x16)		1000192	T10 x 1	
1005681	R24 x 8 (4x16)		1100795	Z x 2	
1109474	R50 x 22		1006103	T3x 8	

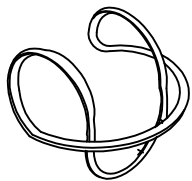
Elementy do dokupienia / Zusätzlich bestellen
Additional elements in sale / Элементы для докупки

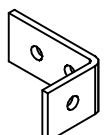
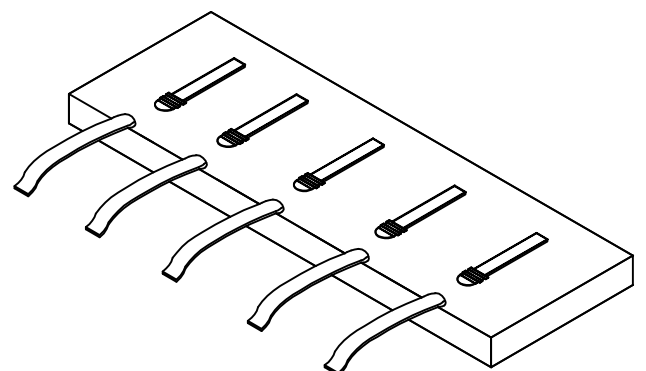
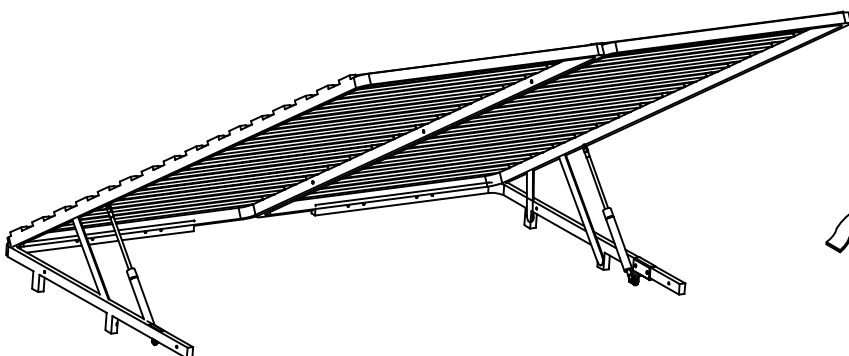

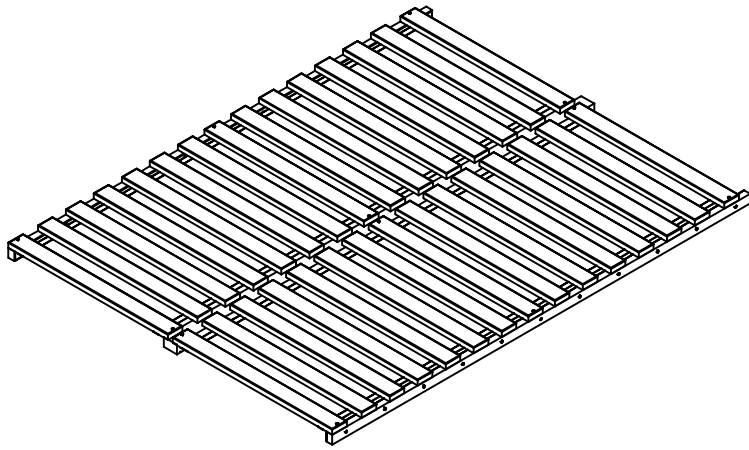

1

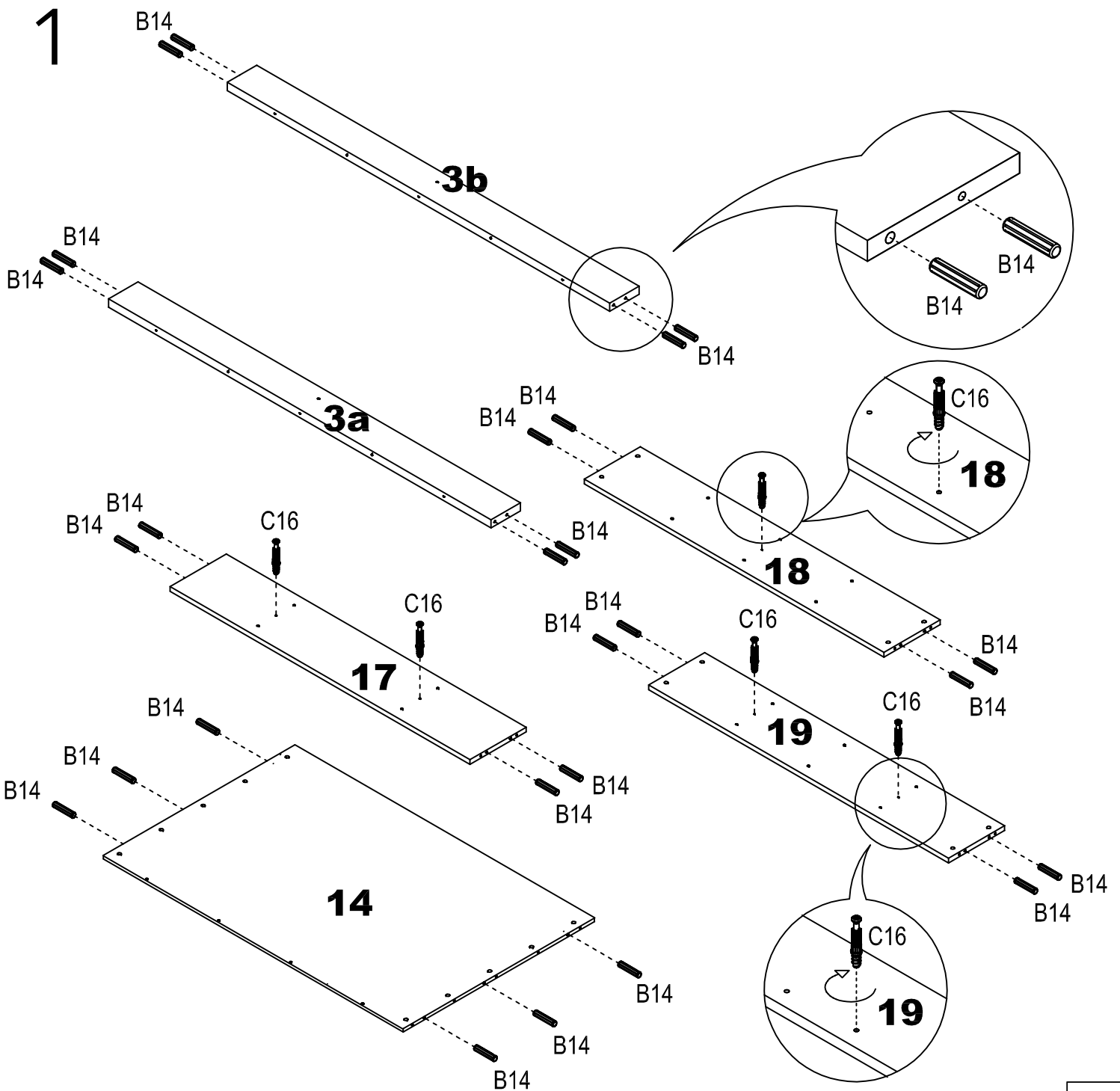

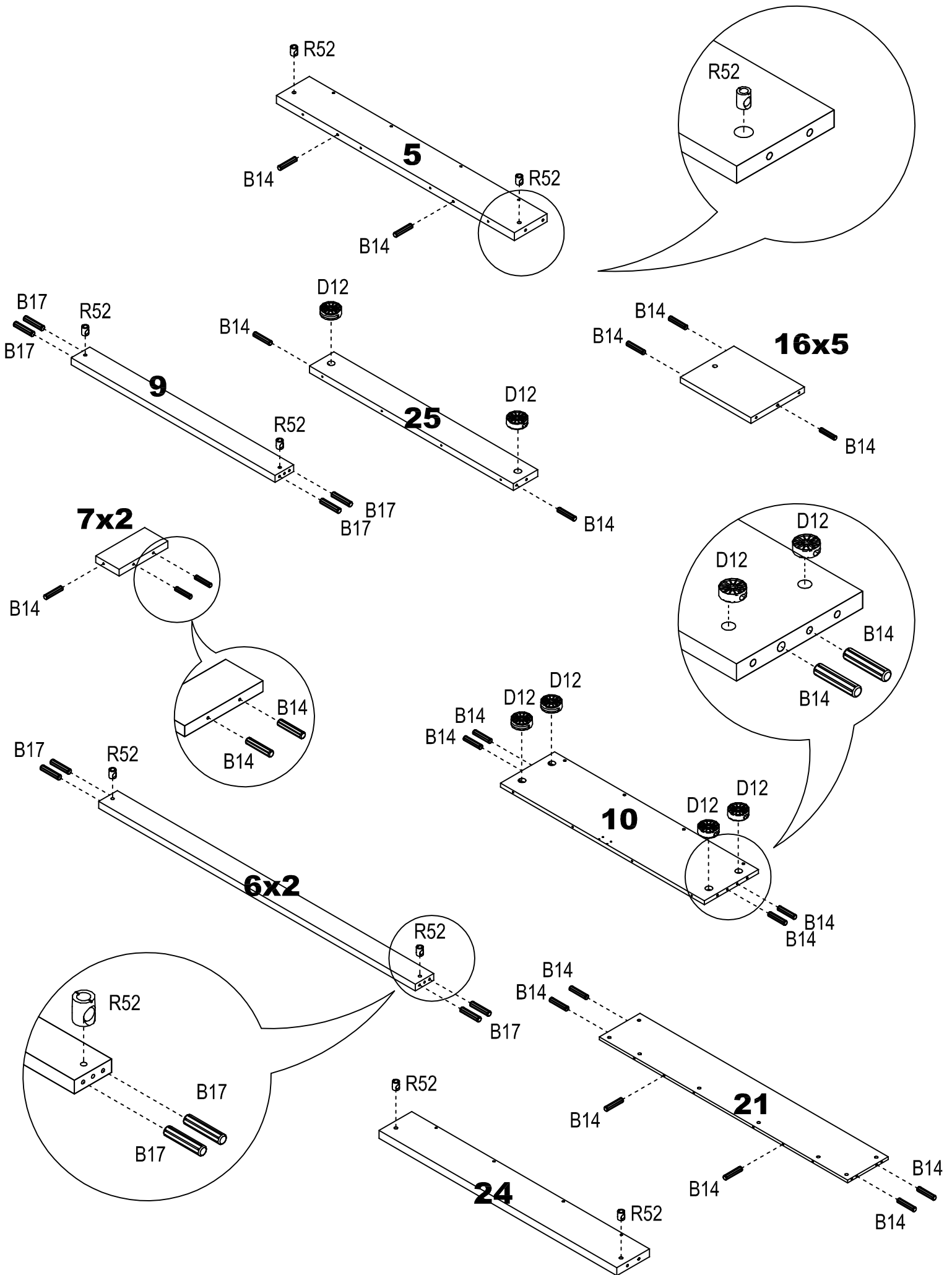

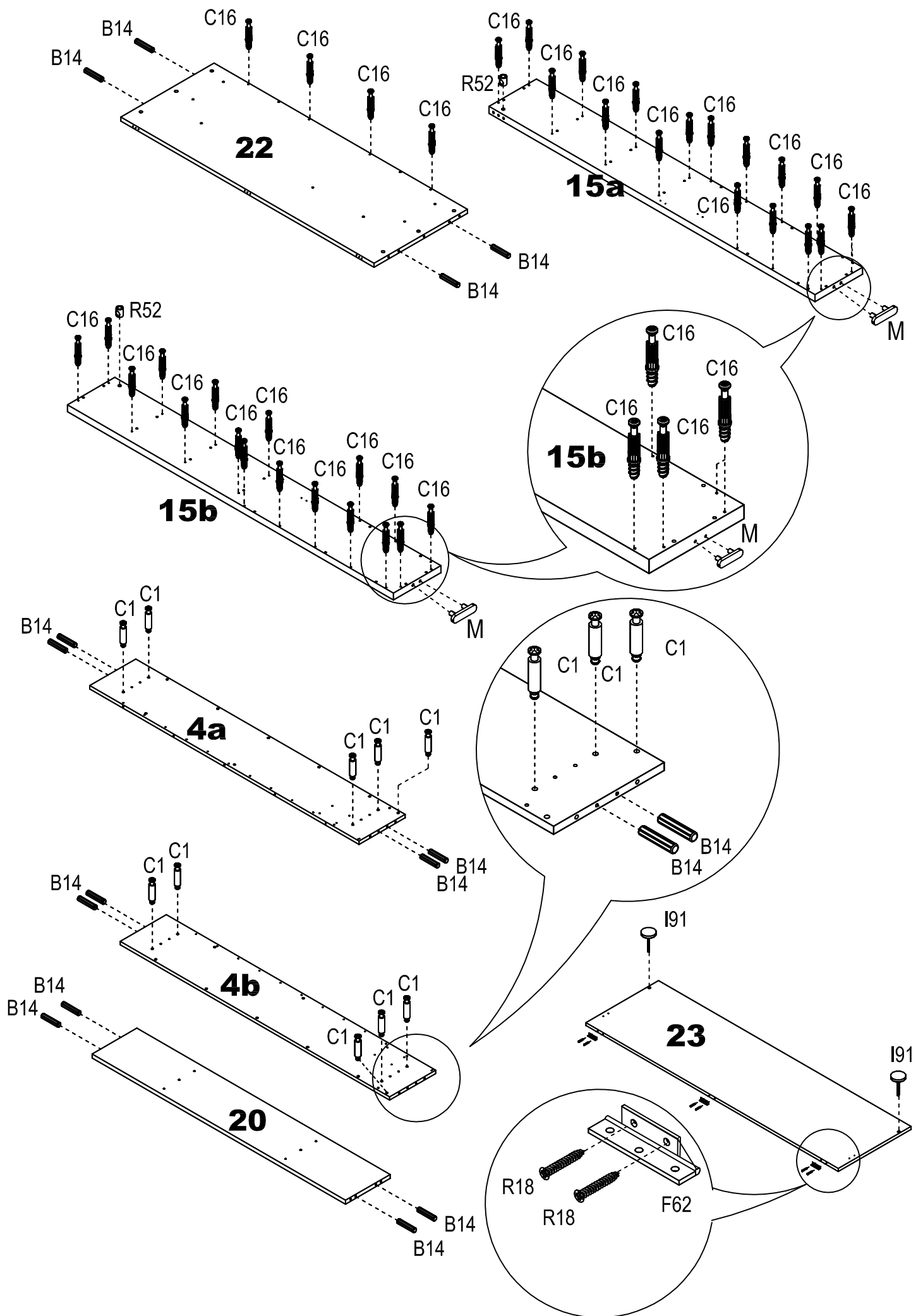

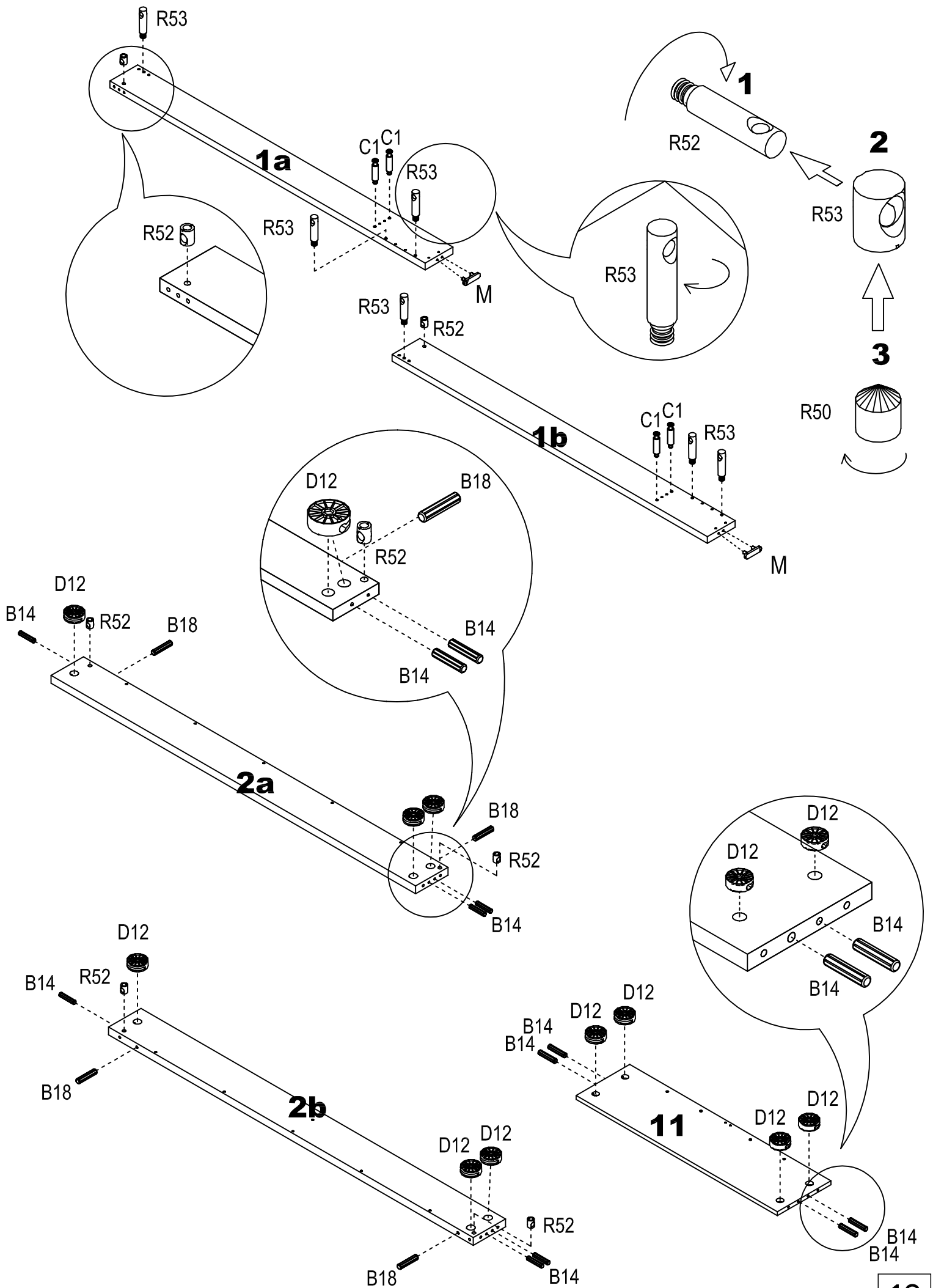

2

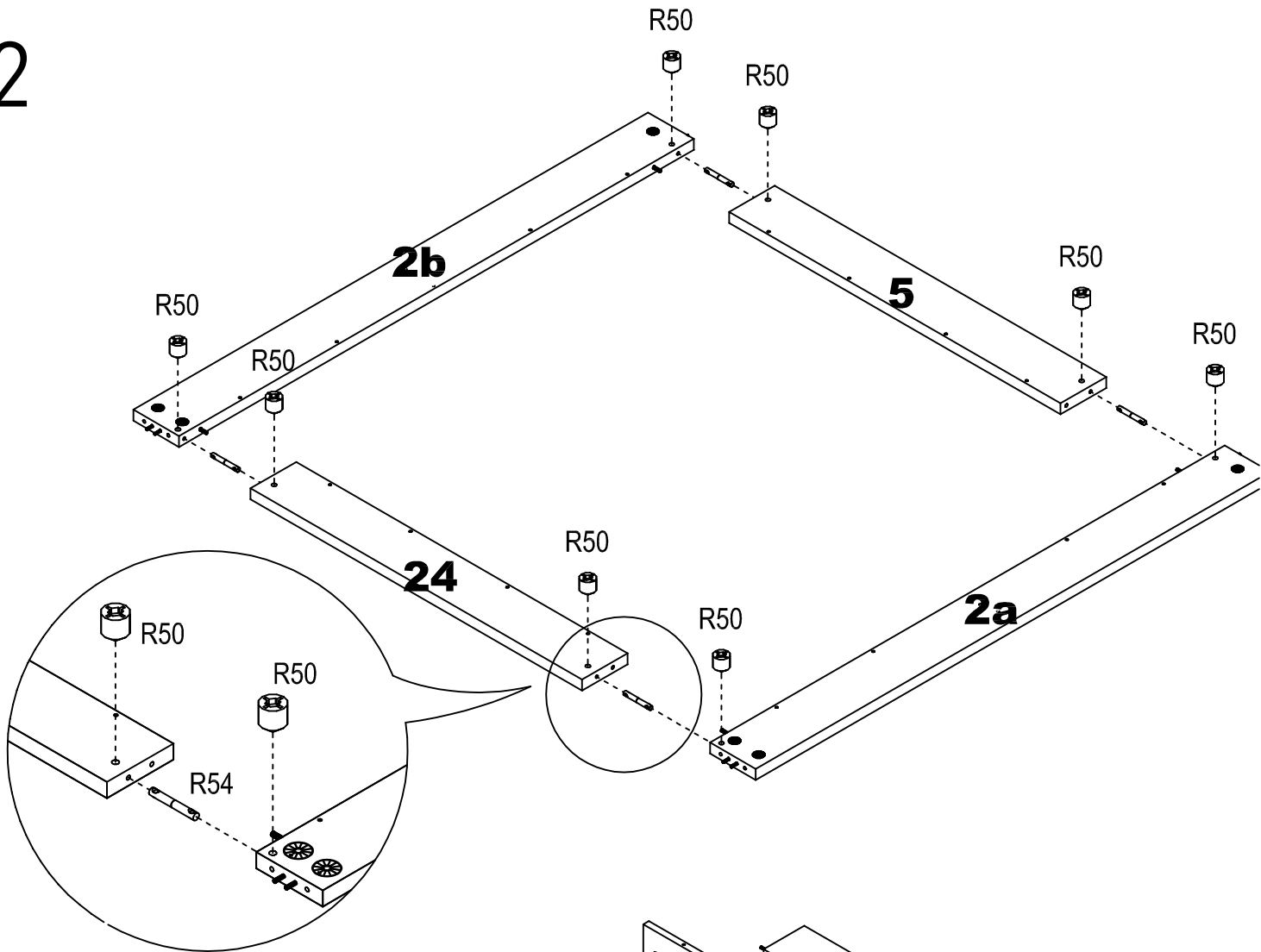

3

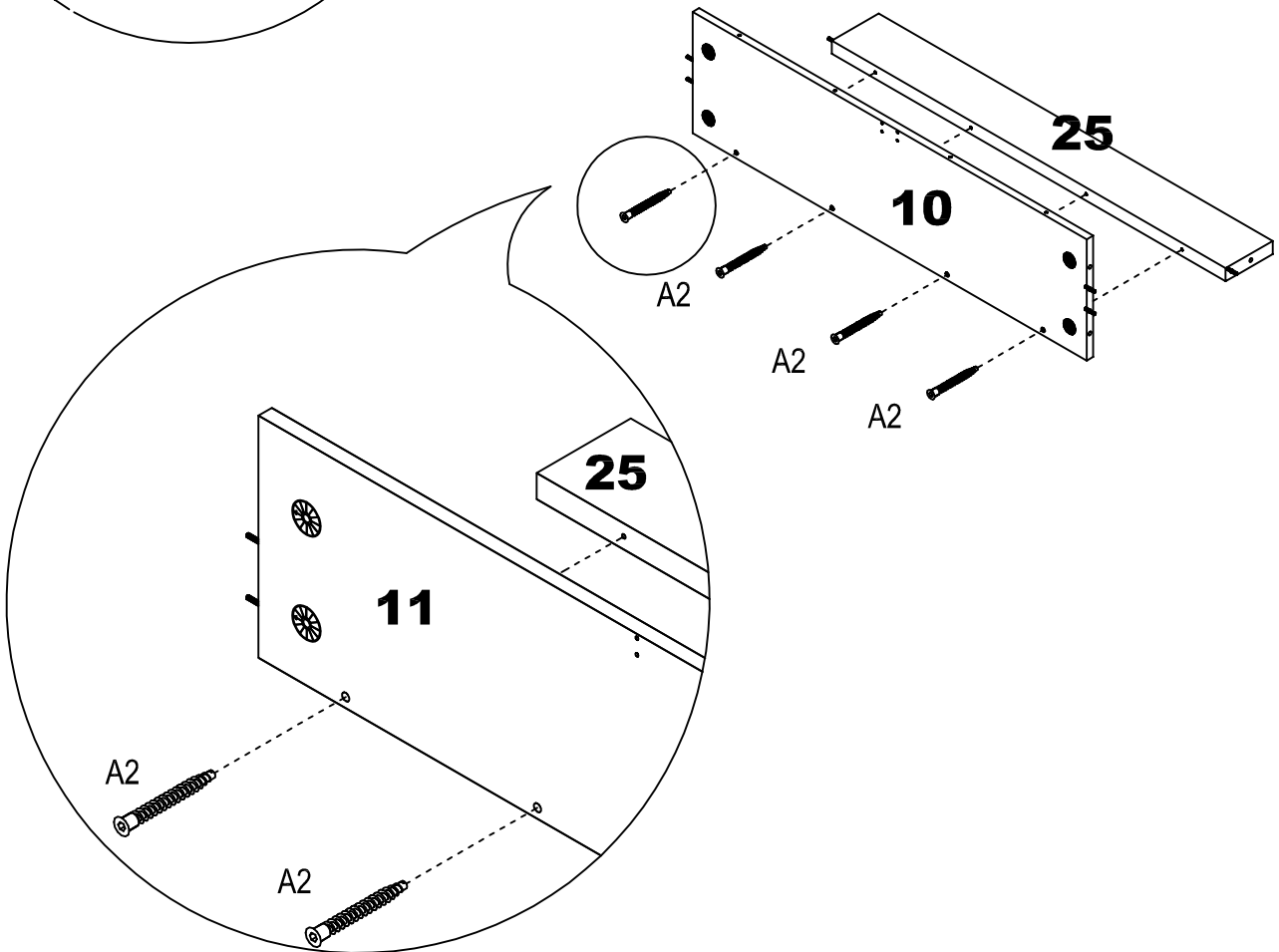

4

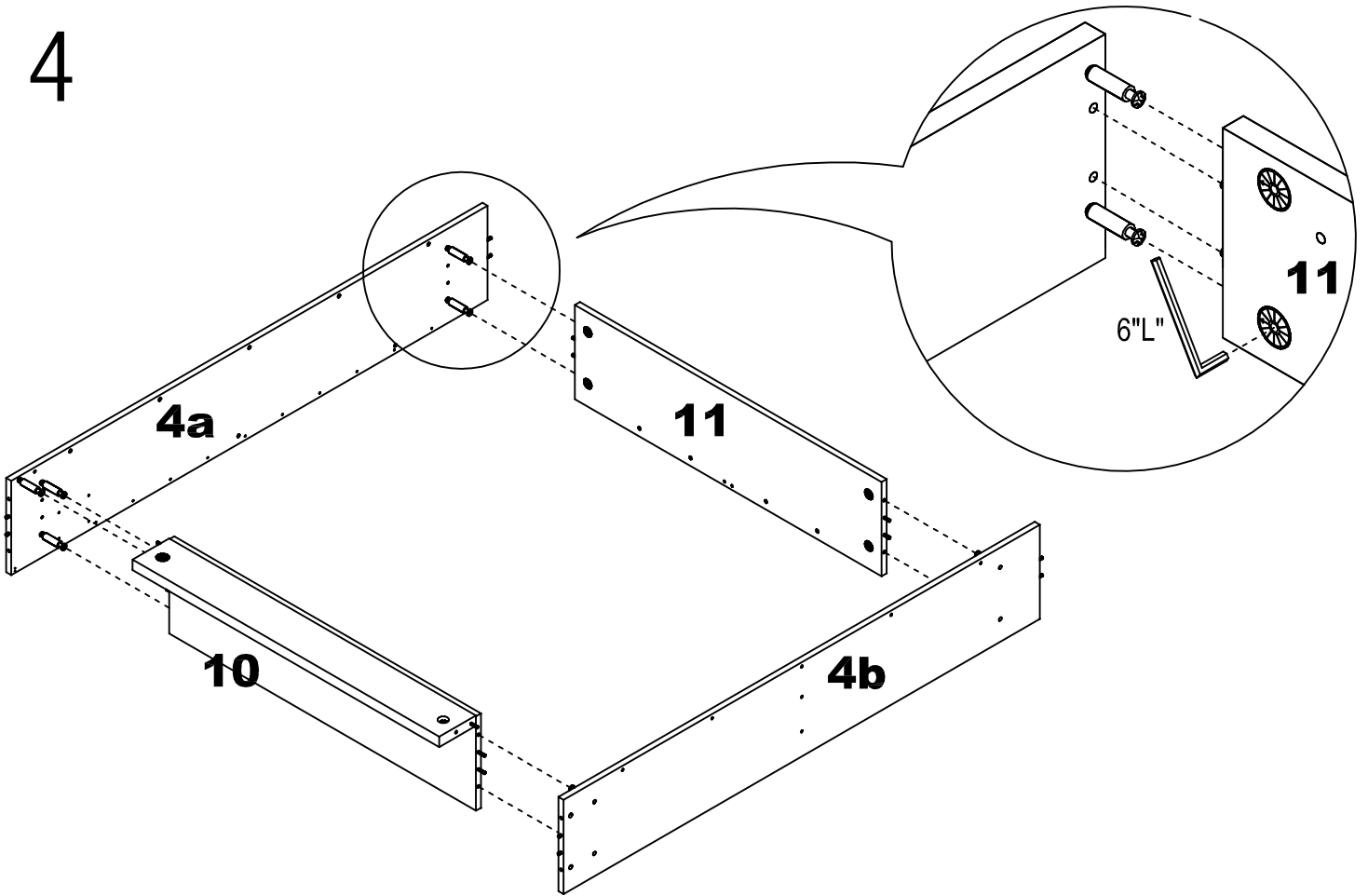

5

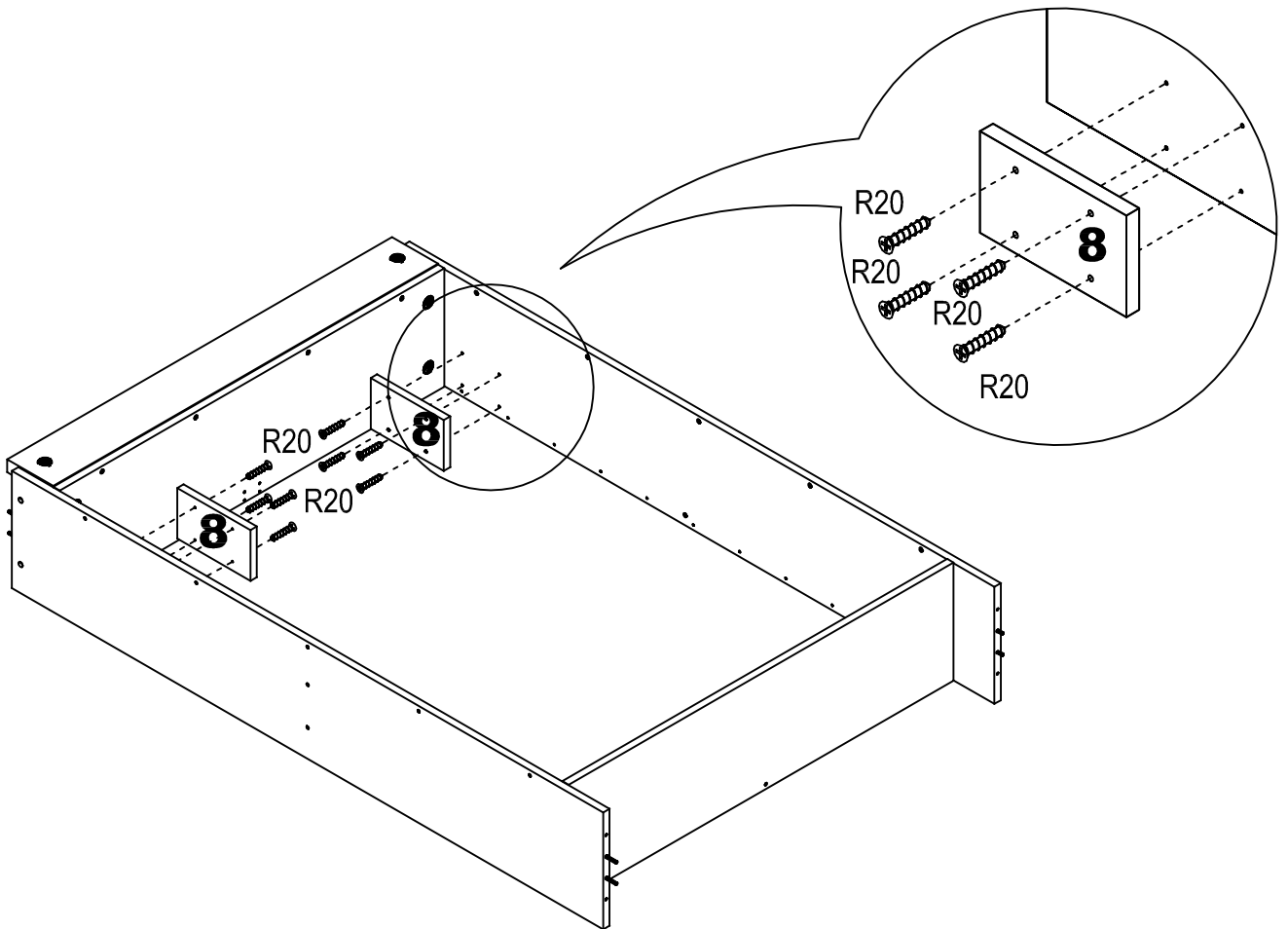

6

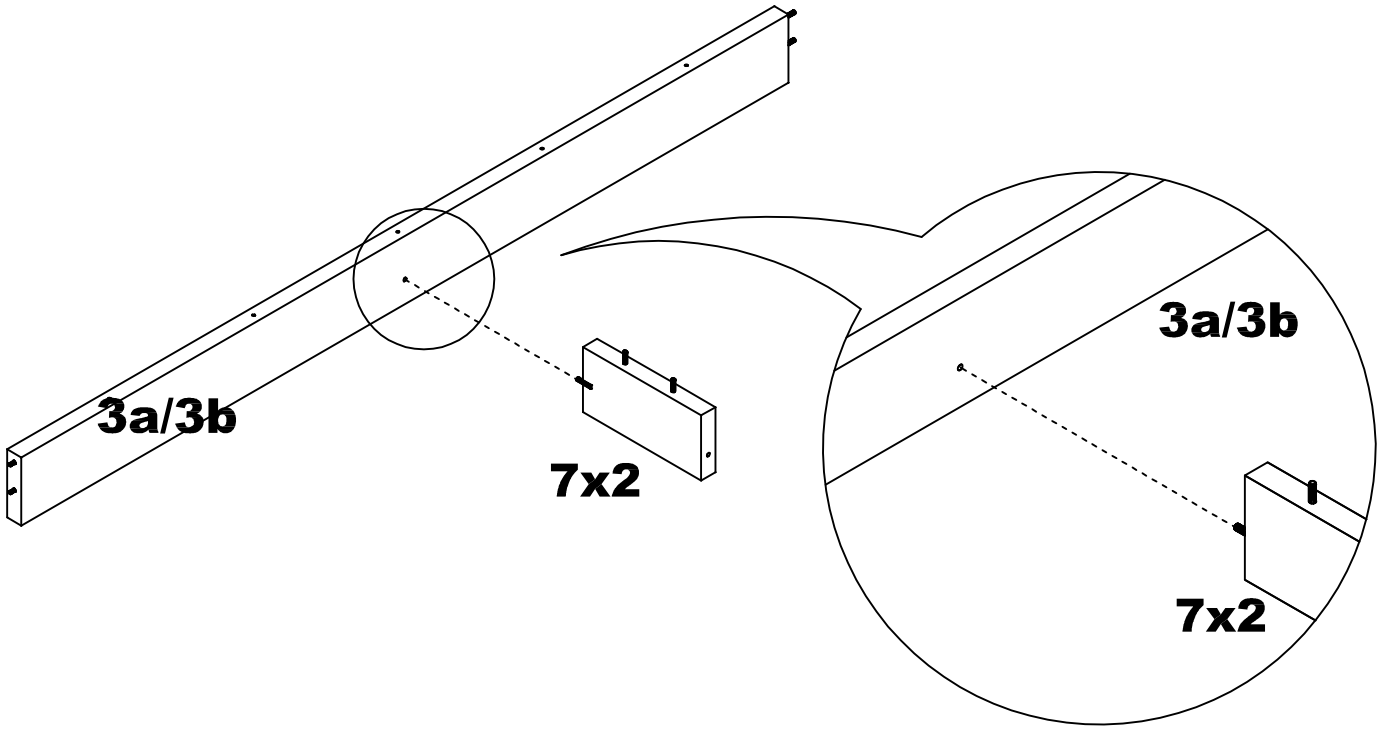

7

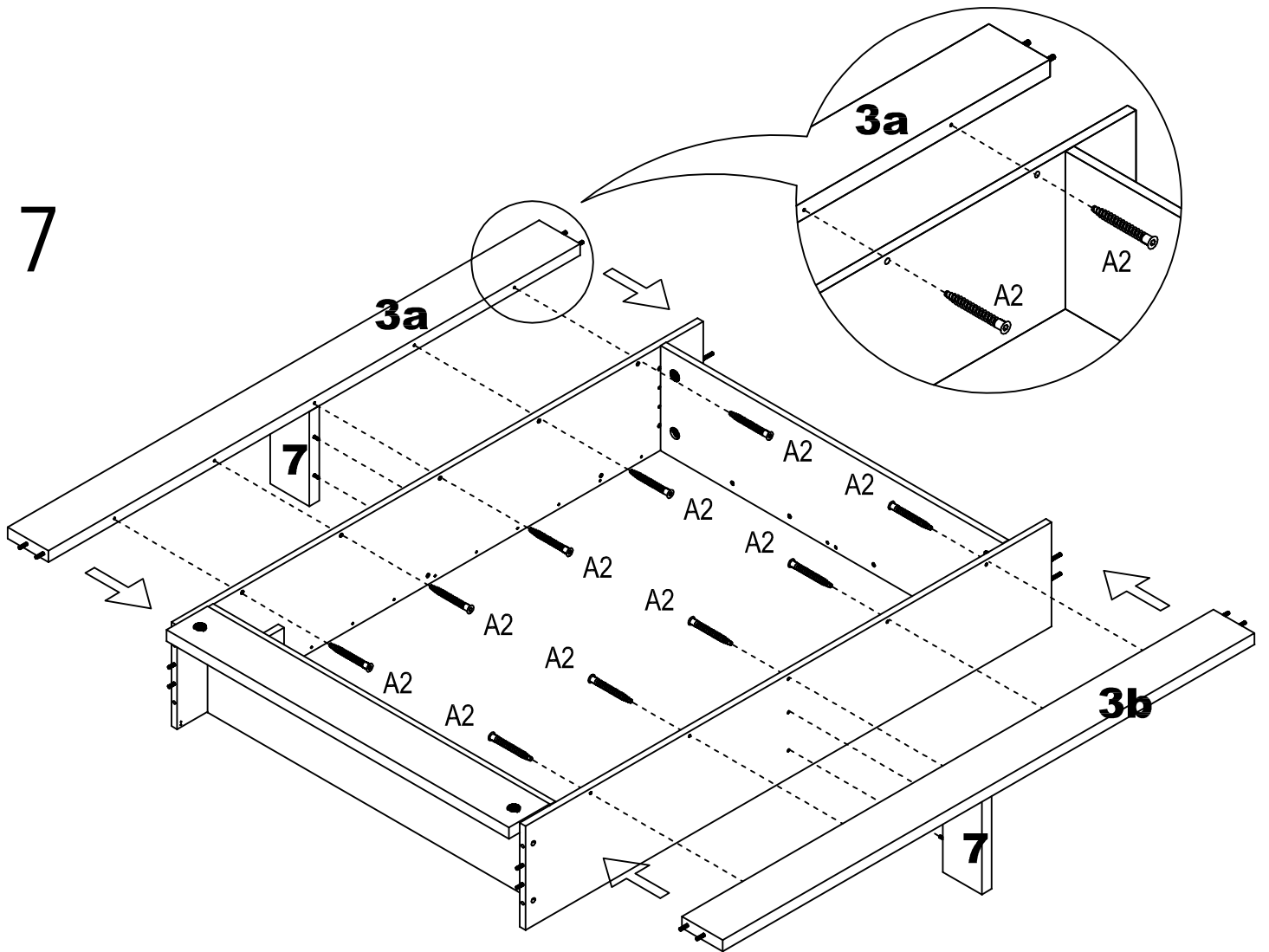

8

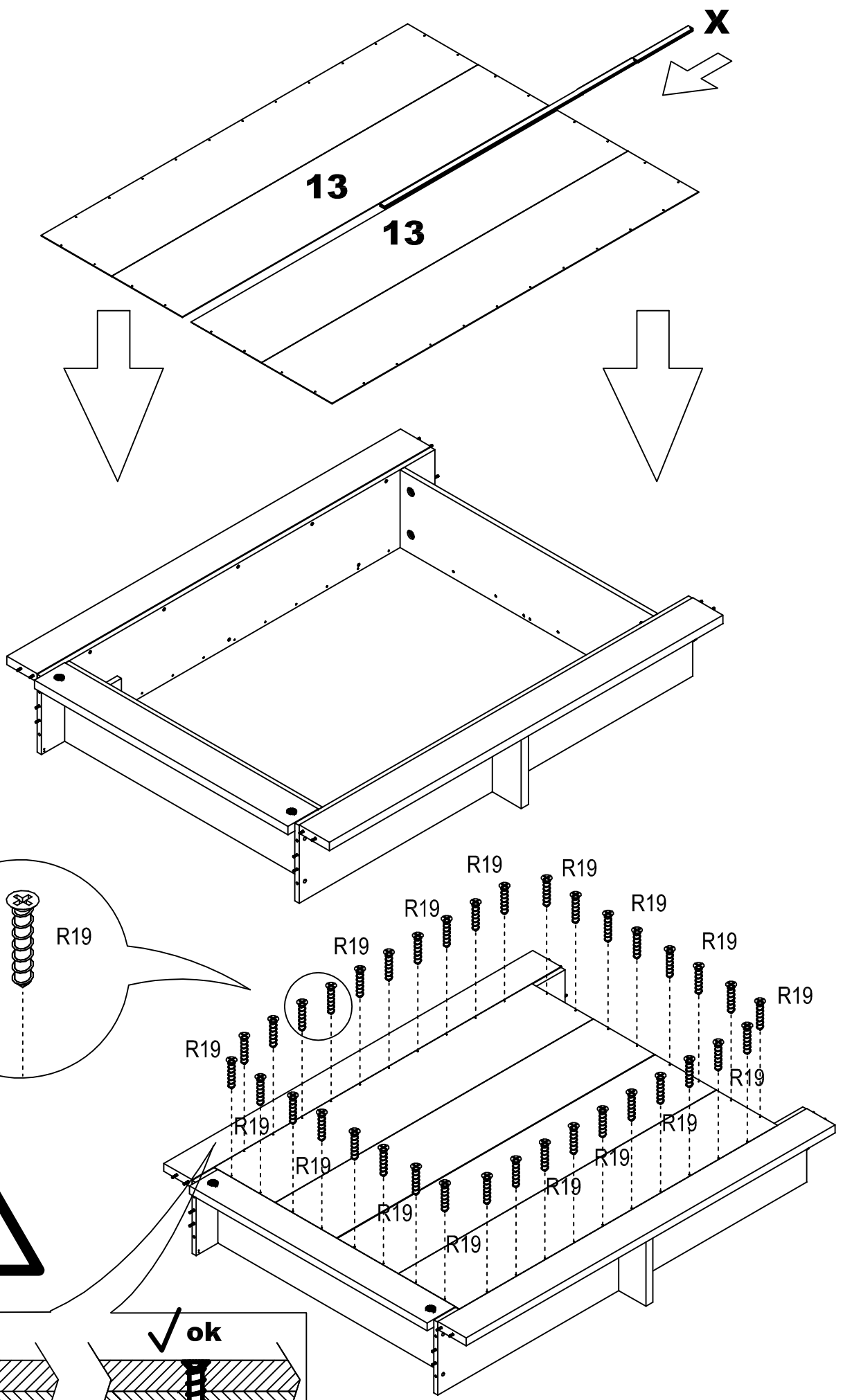

9

180°

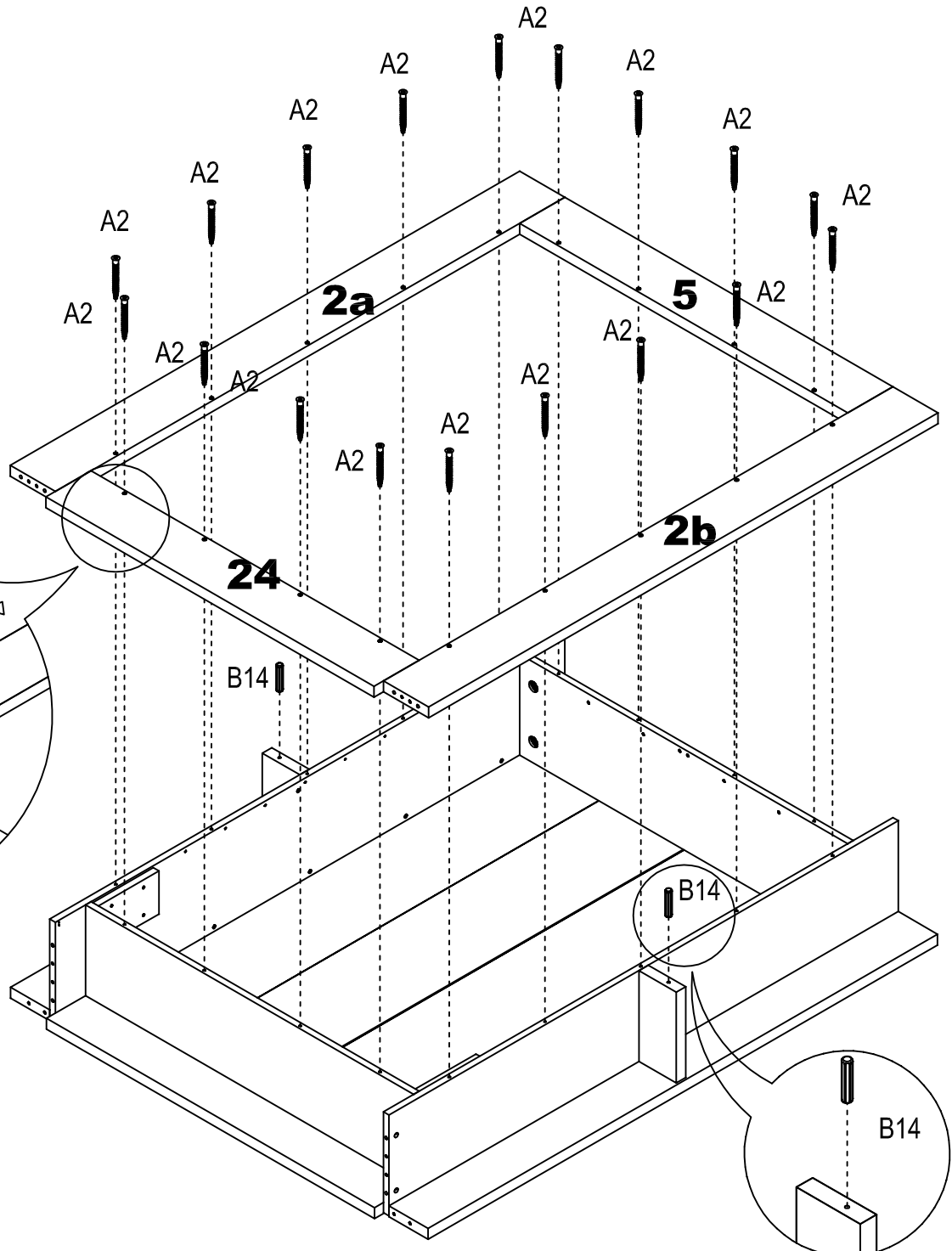
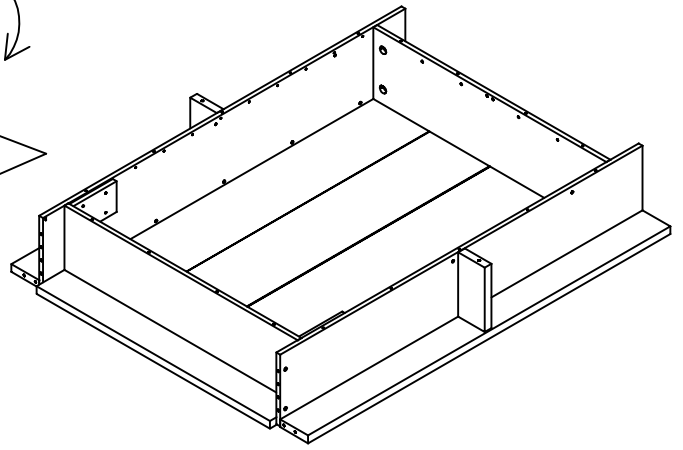
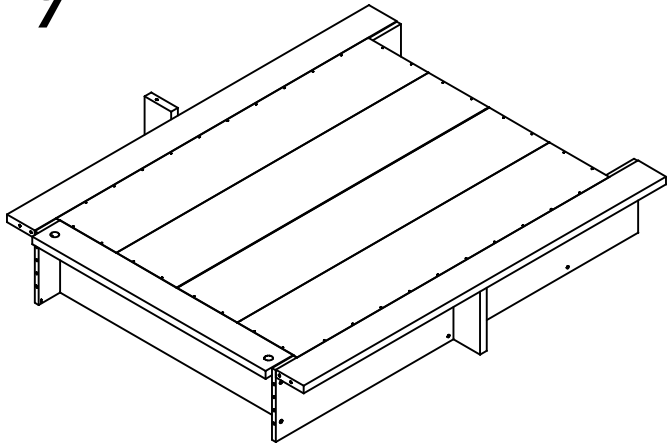
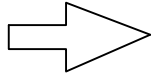

10

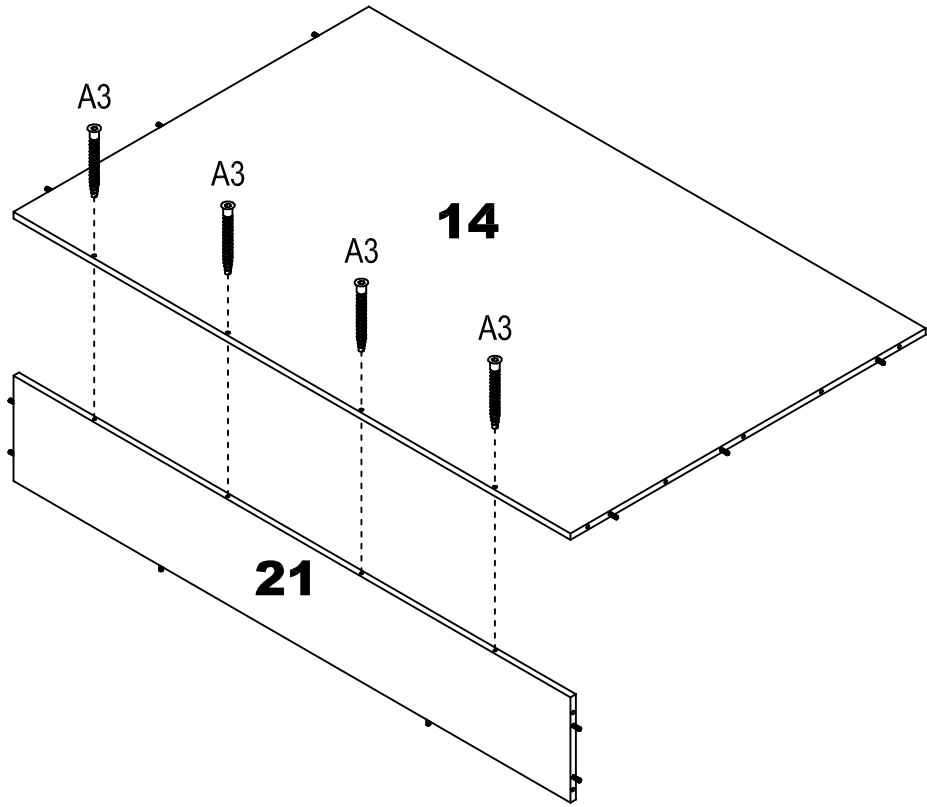

11

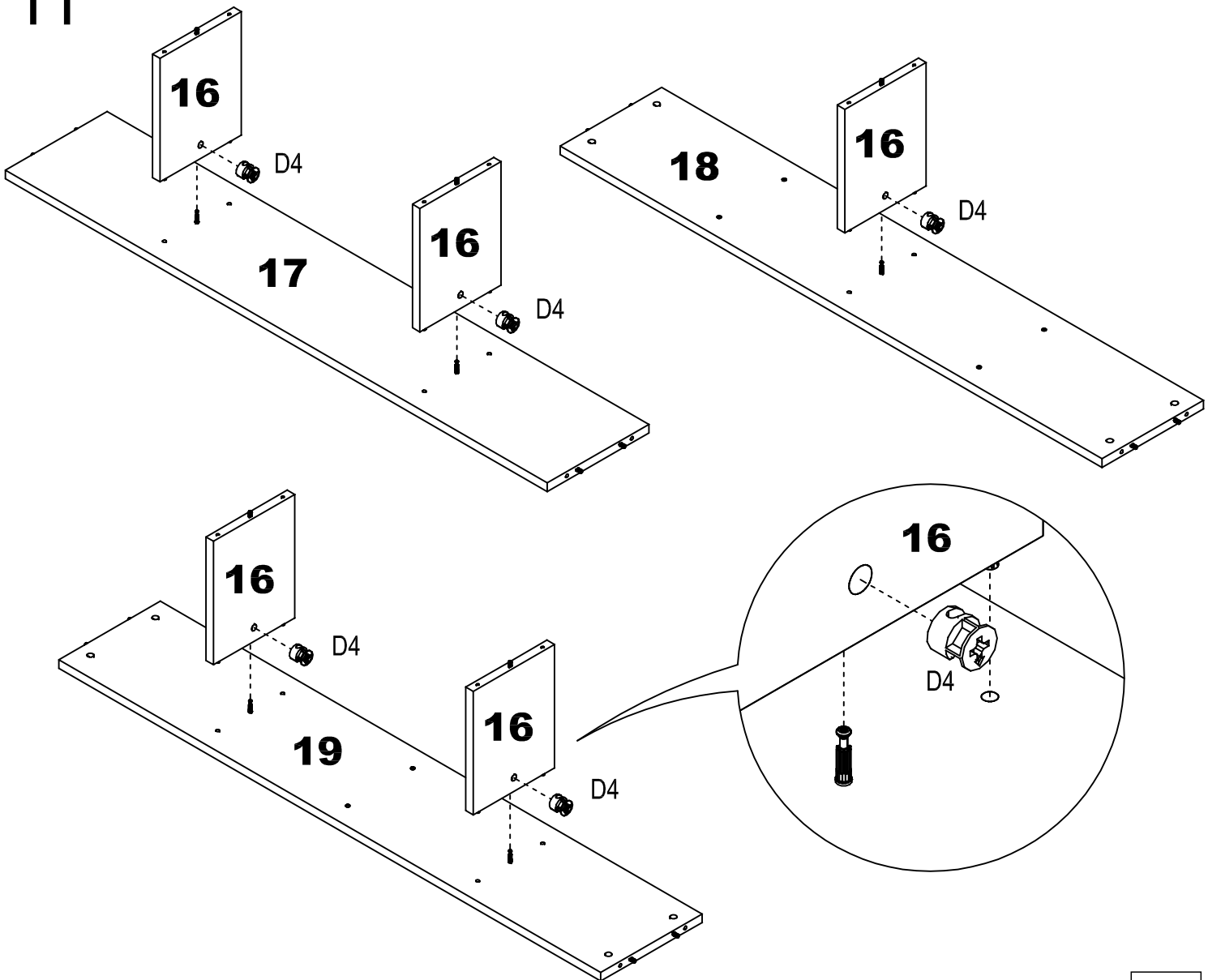

12

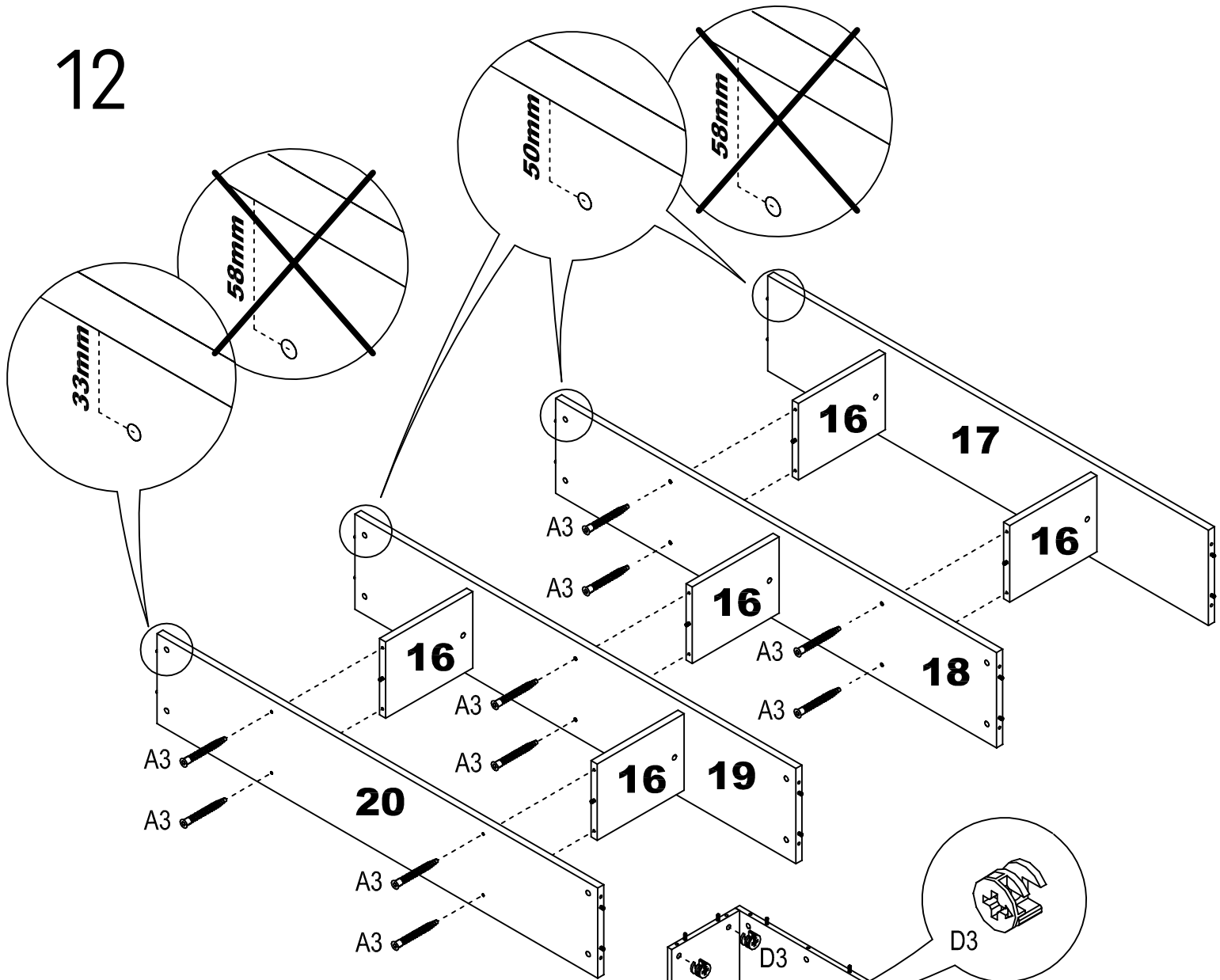

13

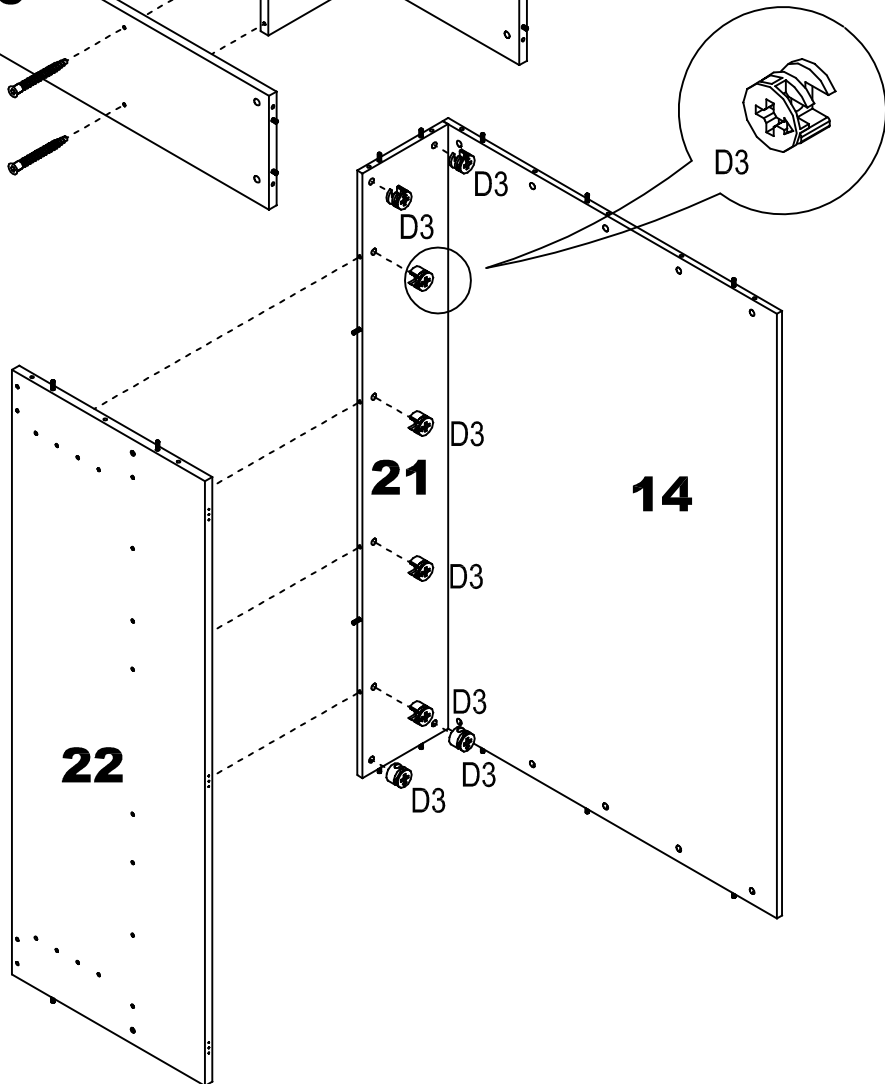

14

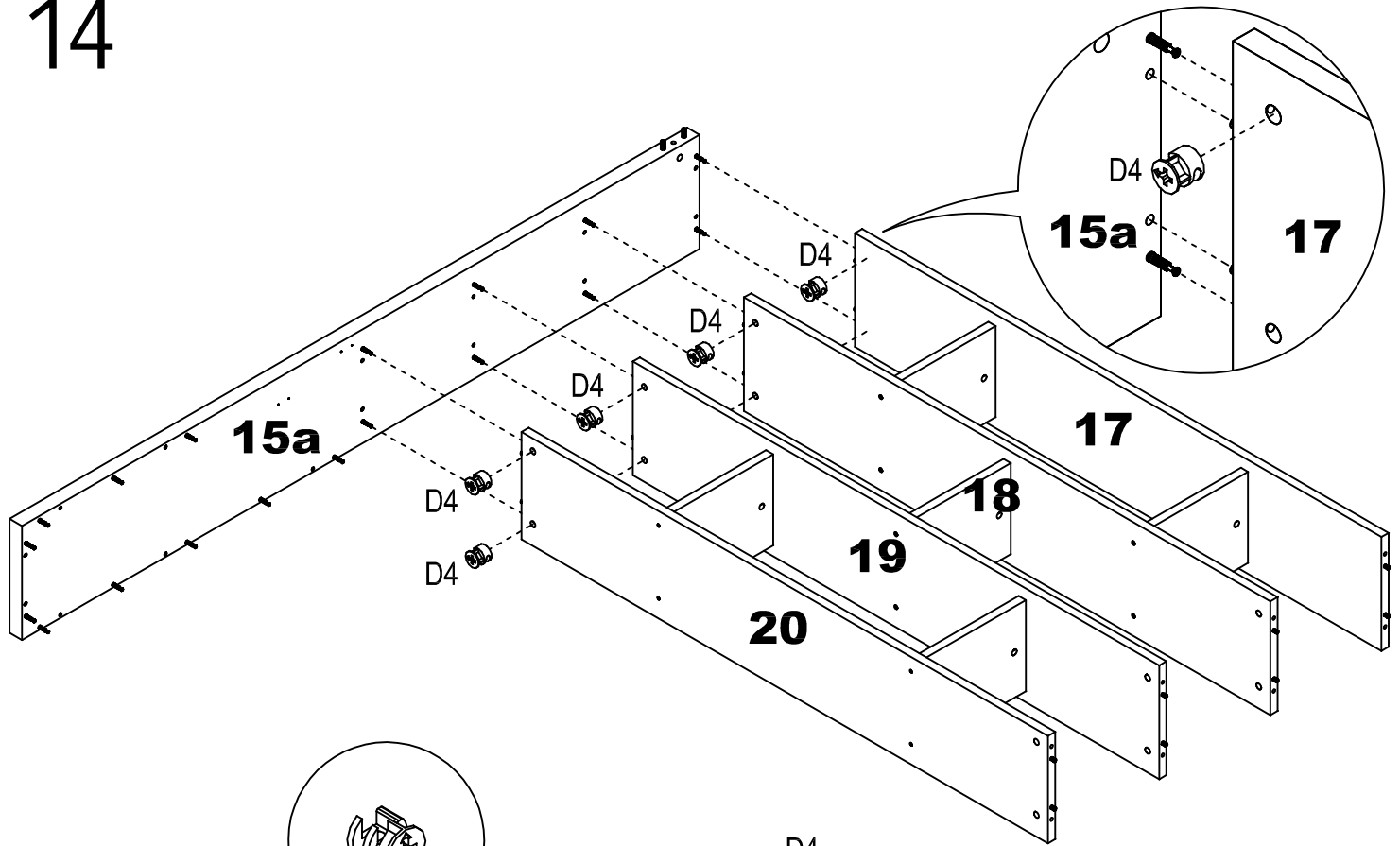

15

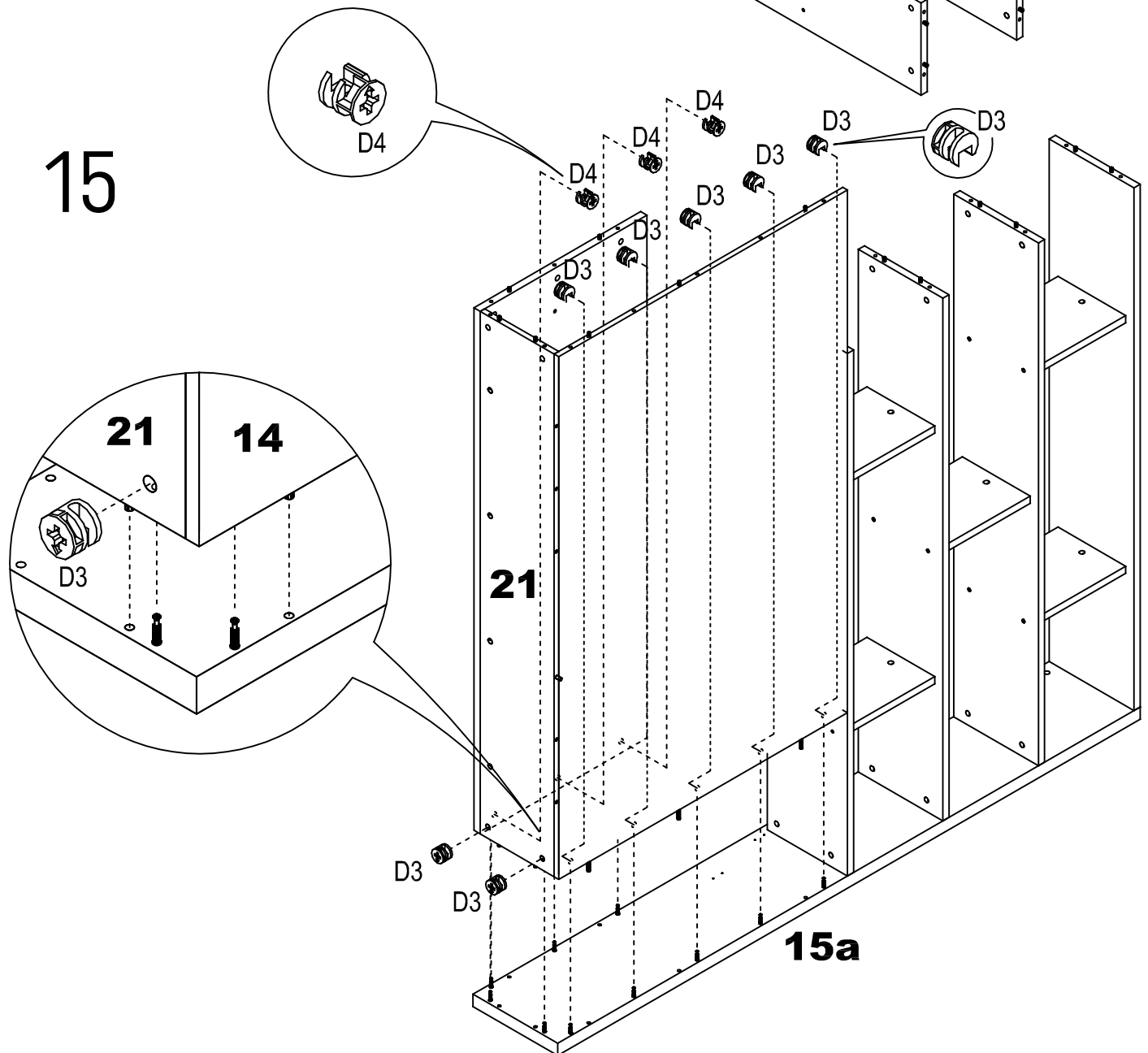

16

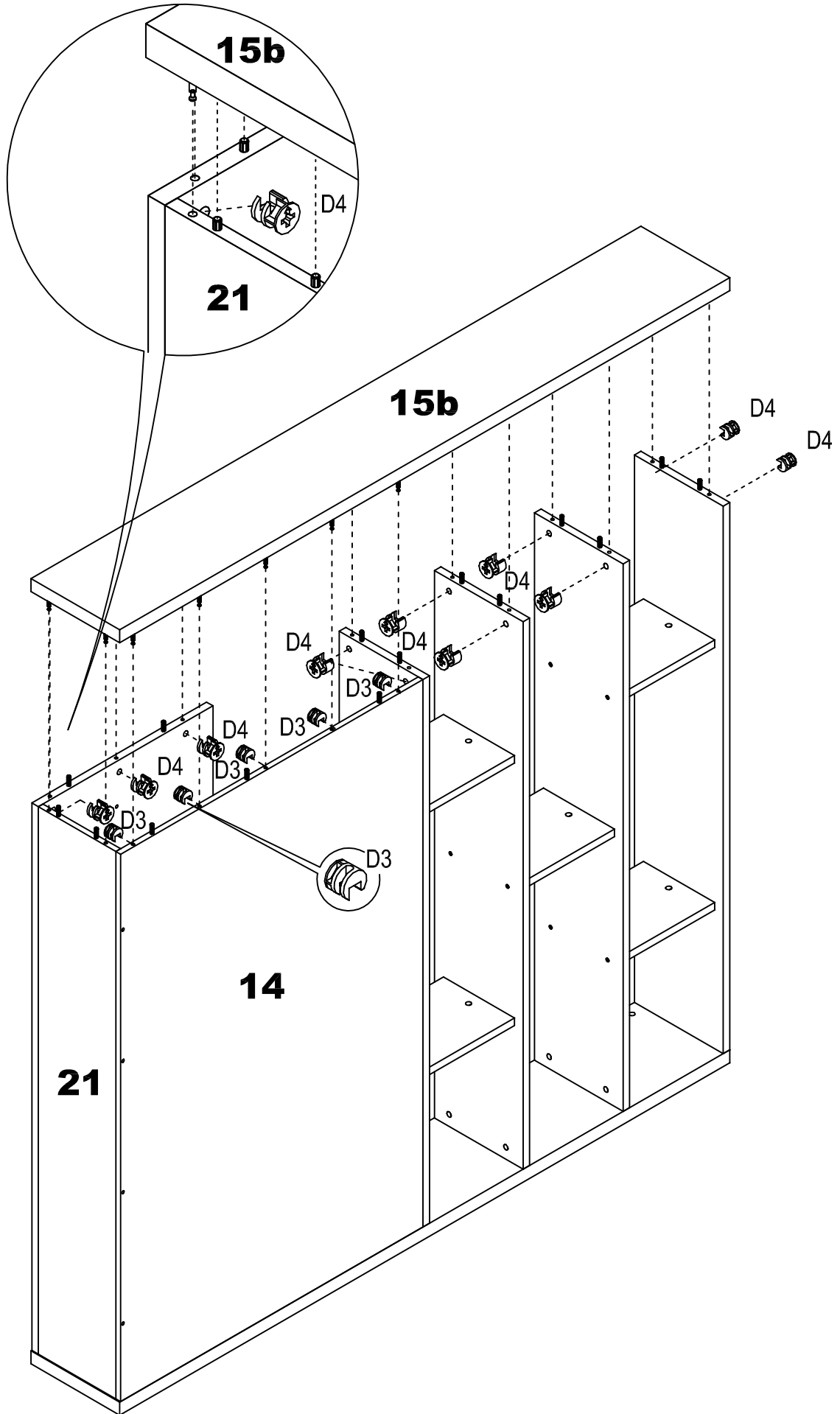

17

Przed przejściem do następnego kroku należy wybrać rodzaj stosowanej podłogi. W przypadku wyboru podłogi drewnianej prosimy zamontować ją w tym kroku według instrukcji montażu do niej załączonej.

Before going to the next stage you have to choose what kind of mattress base you're going to use. If you decide for wooden base, please install it at this stage according to the assembly instruction attached.

Bevor Sie zum nächsten Schritte gehen, müssen Sie sich entscheiden, welche Art von Lattenrost Sie benutzen werden. Bei Lattenrost aus Holz ist der in diesem Schritt nach den beigefügten Aufbauanleitungen zu montieren.

Перед следующим шагом надо выбрать тип применяемого основания. В случае выбора деревянного основания просим ее установить в данном моменте согласно прикрепленной инструкции сборки.

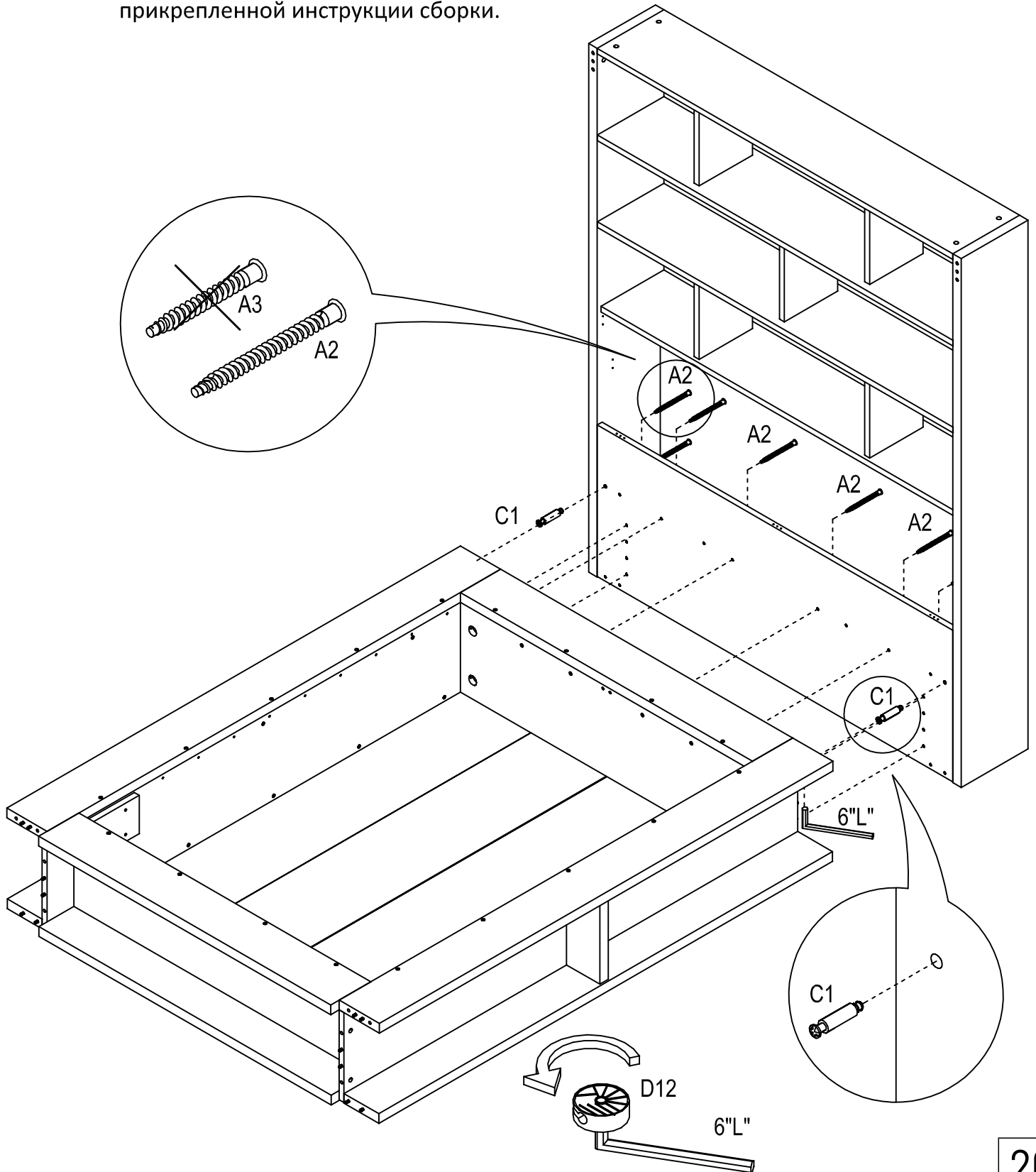

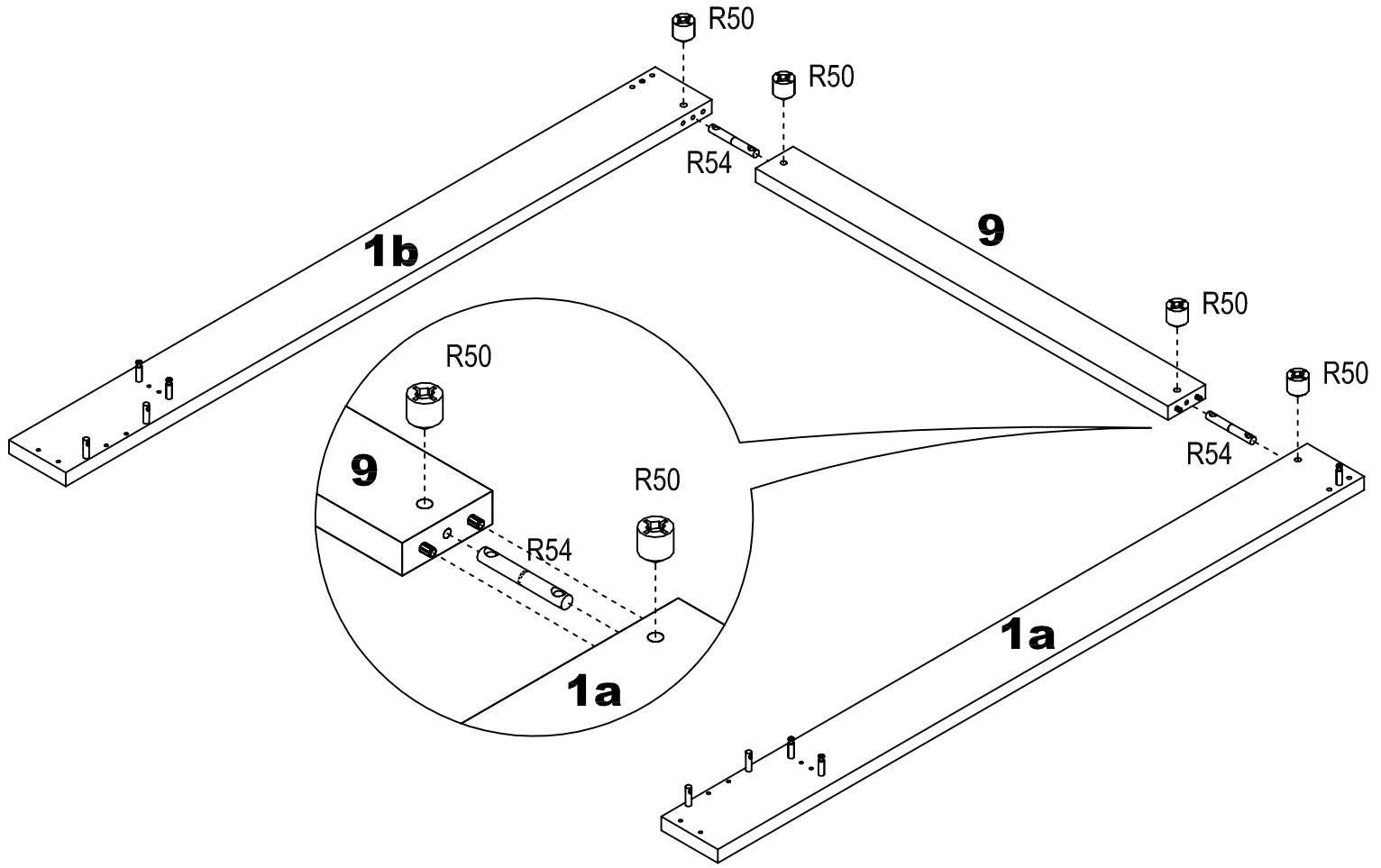

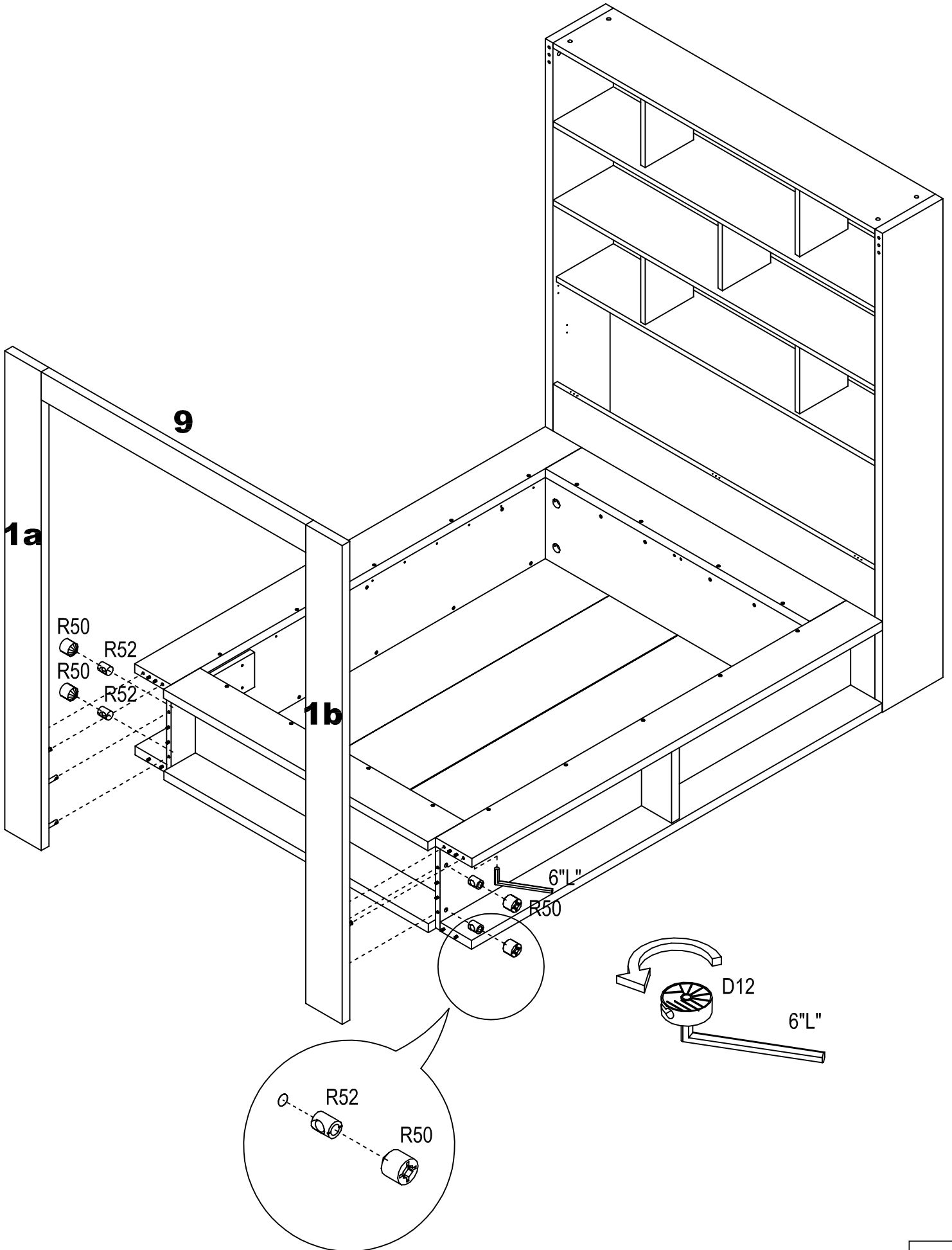

20

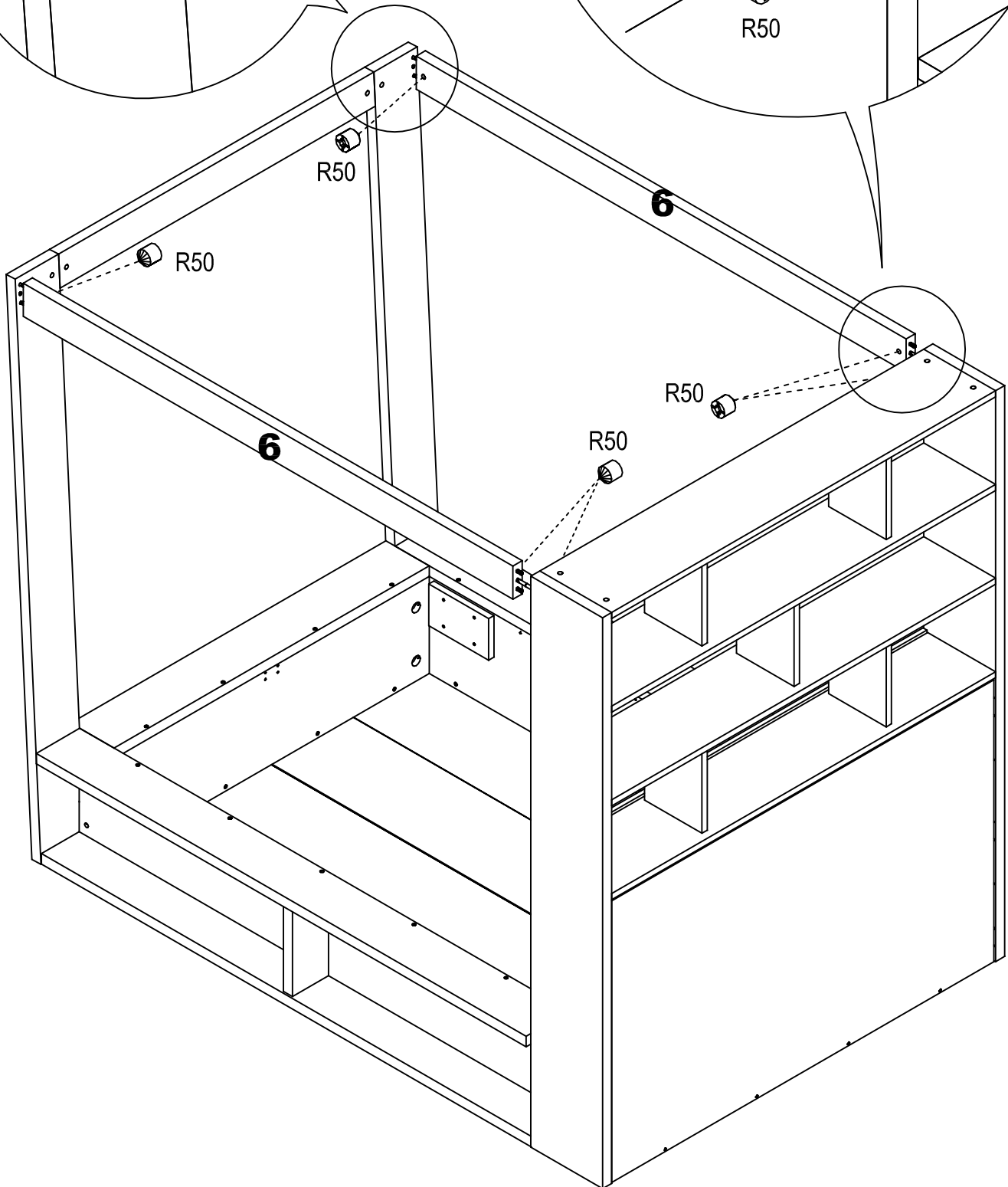
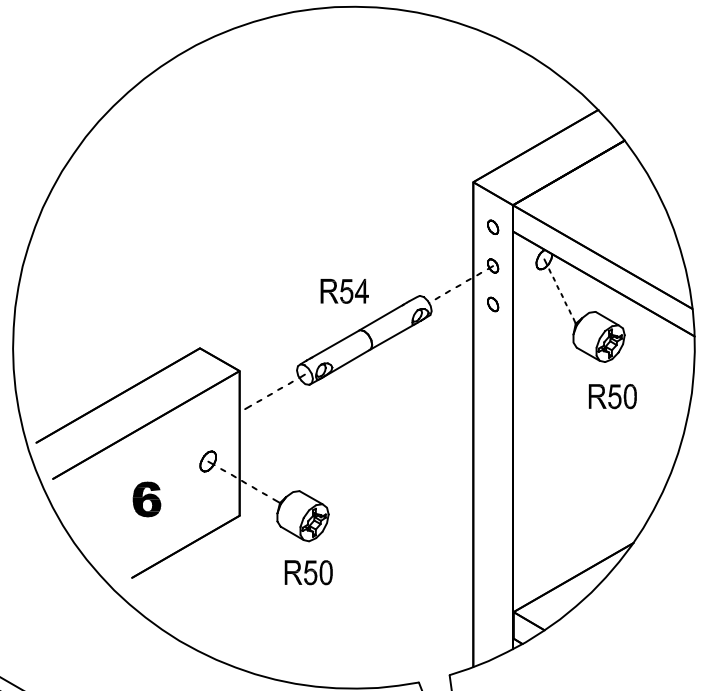
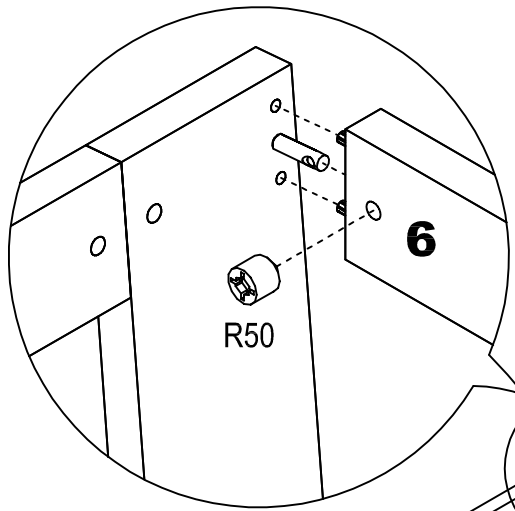

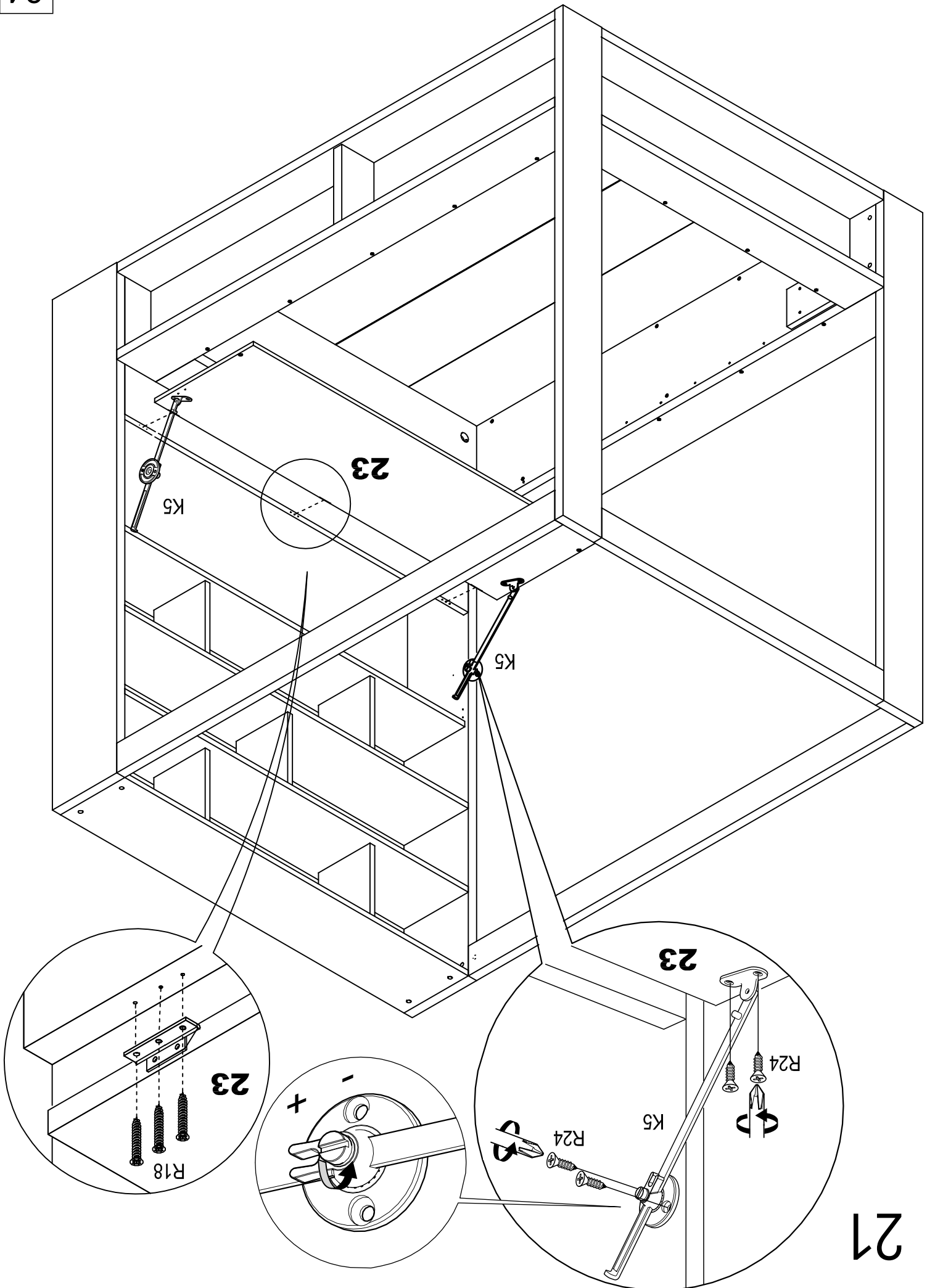

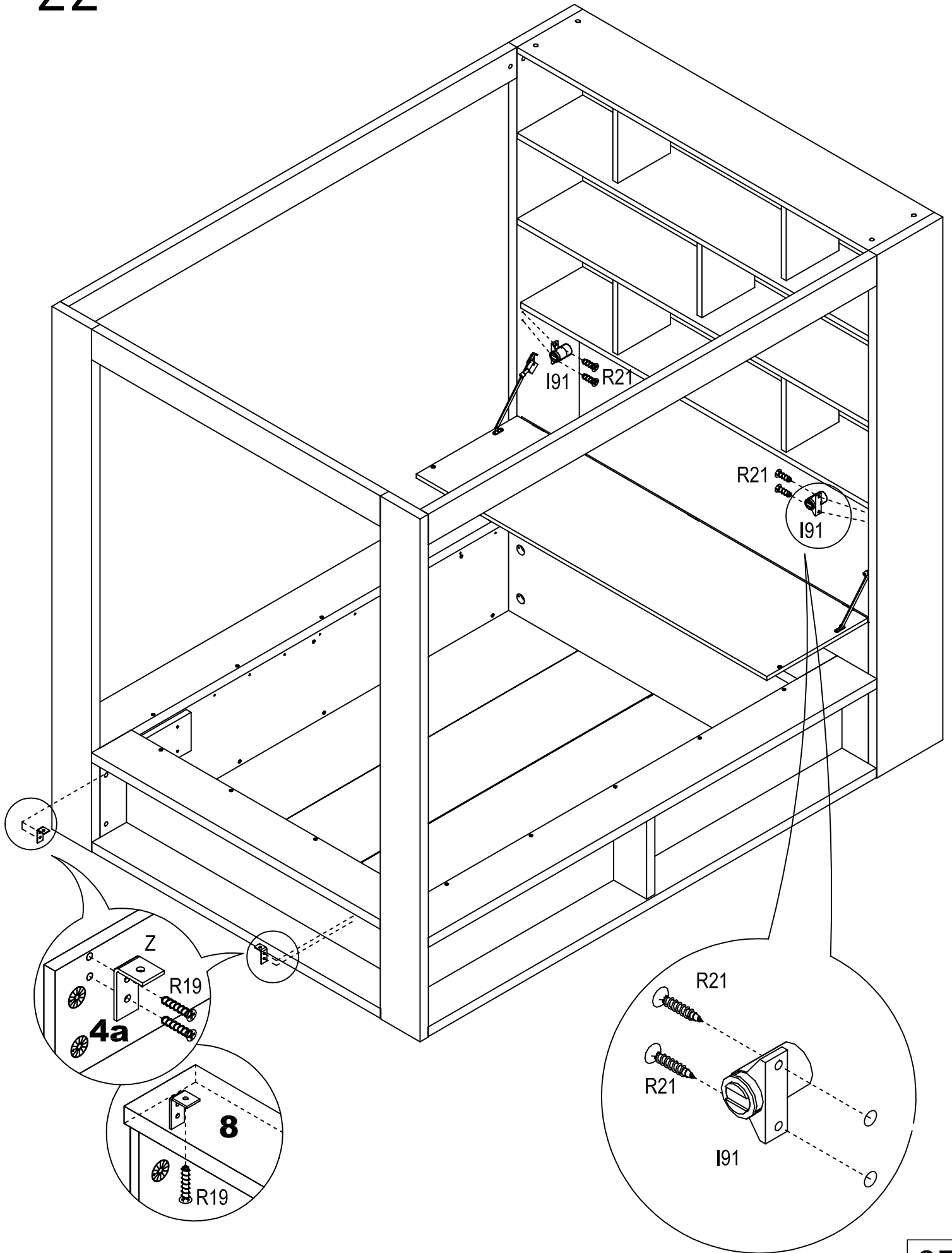

UWAGA! Montaż elementu do dokupienia!

ACHTUNG! Die Montage des Zukaufelementes!

ATTENTION! Assembling of the element to be bought in addition!

ВНИМАНИЕ! Монтаж элемента для докупки

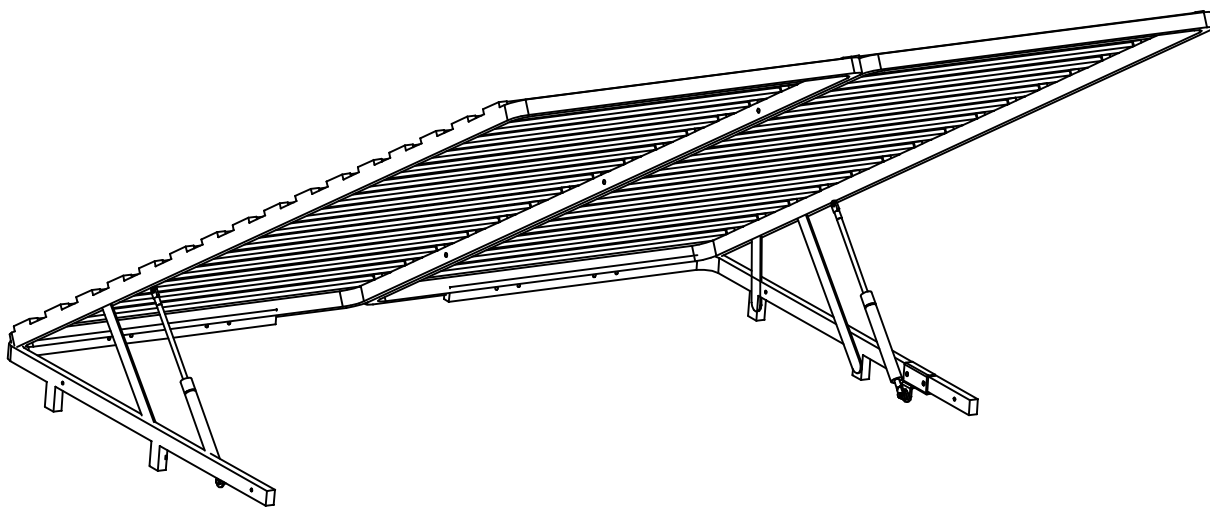

23

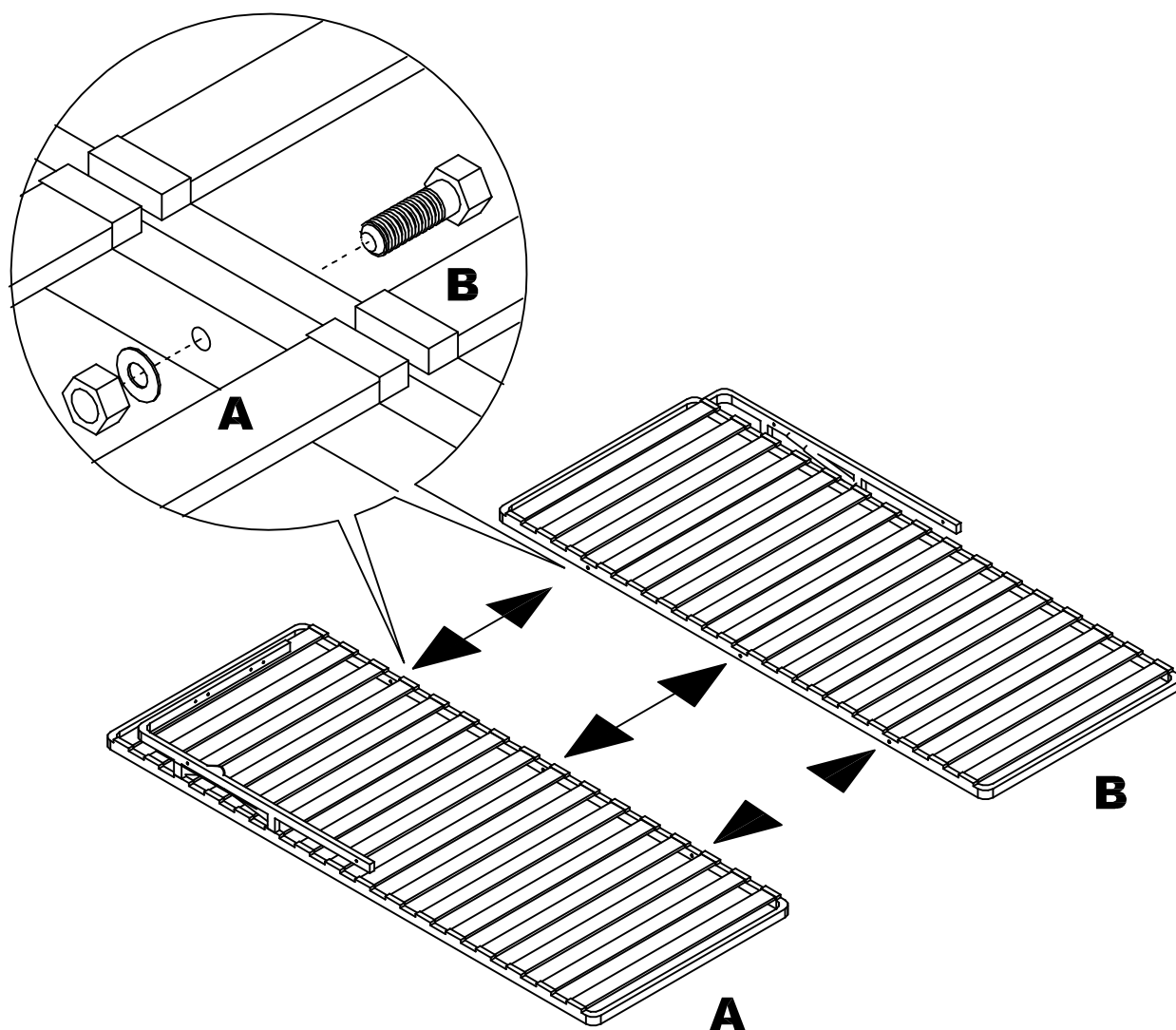

24

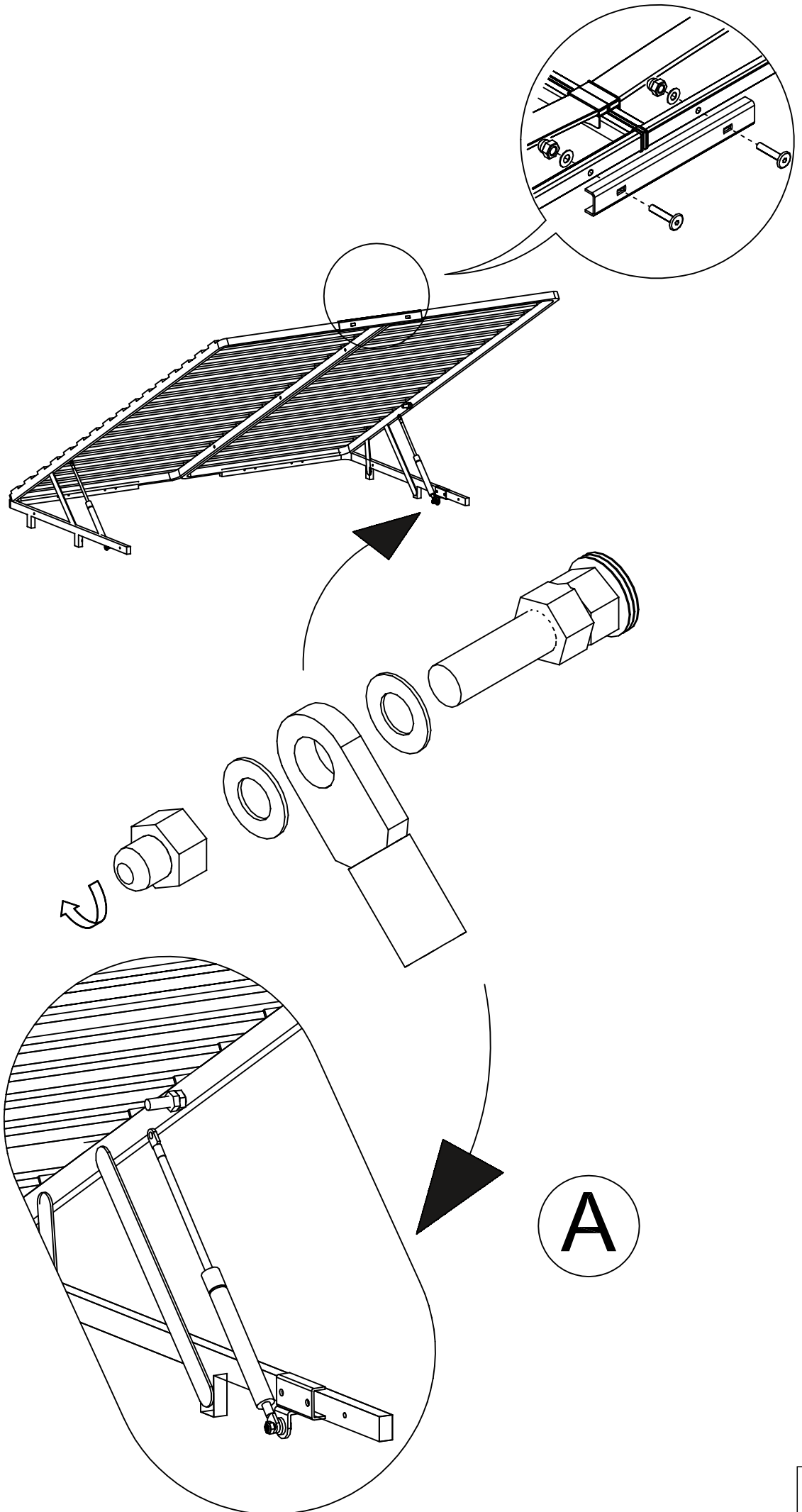

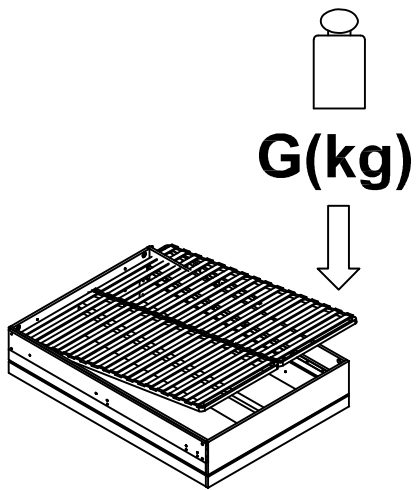

(A) 1 - 1 G - MAX 40 kg

(B) 2 - 2 G - MAX 50 kg

(C) 3 - 3 G - MAX 60 kg

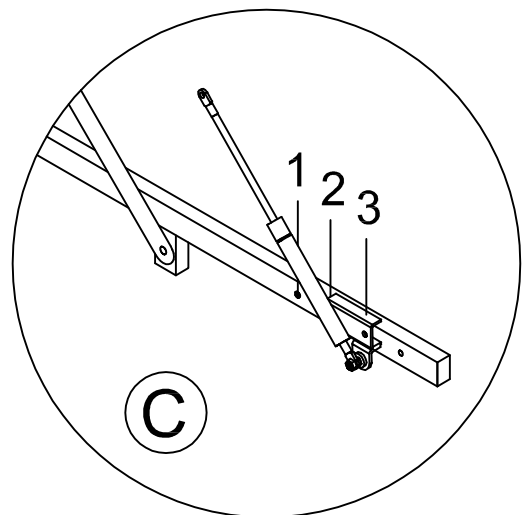
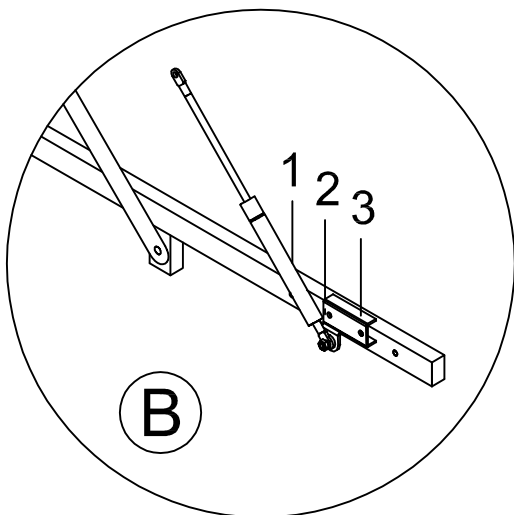
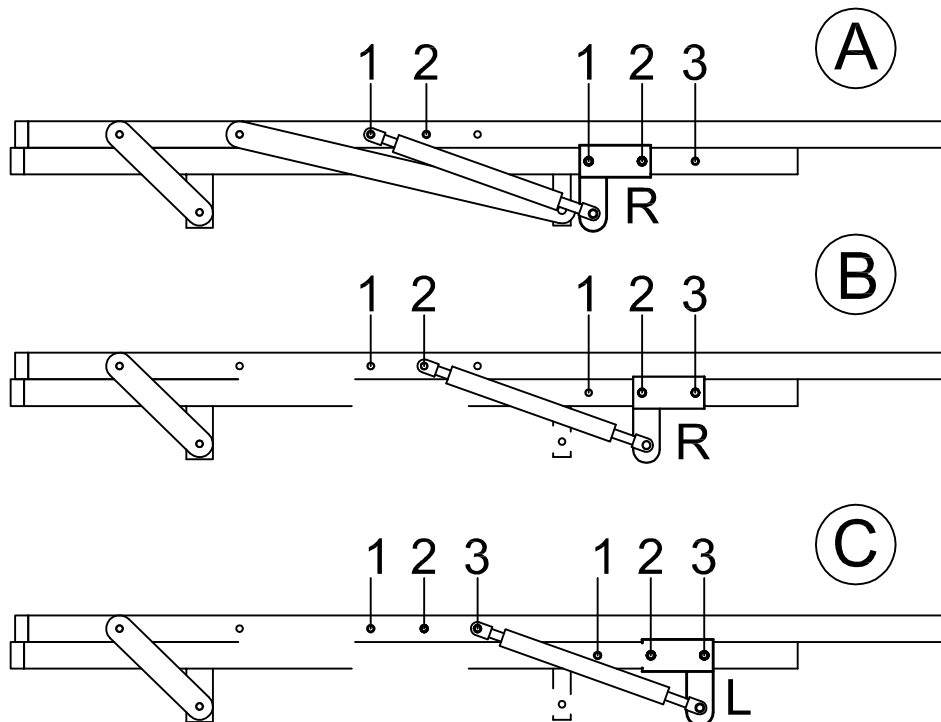

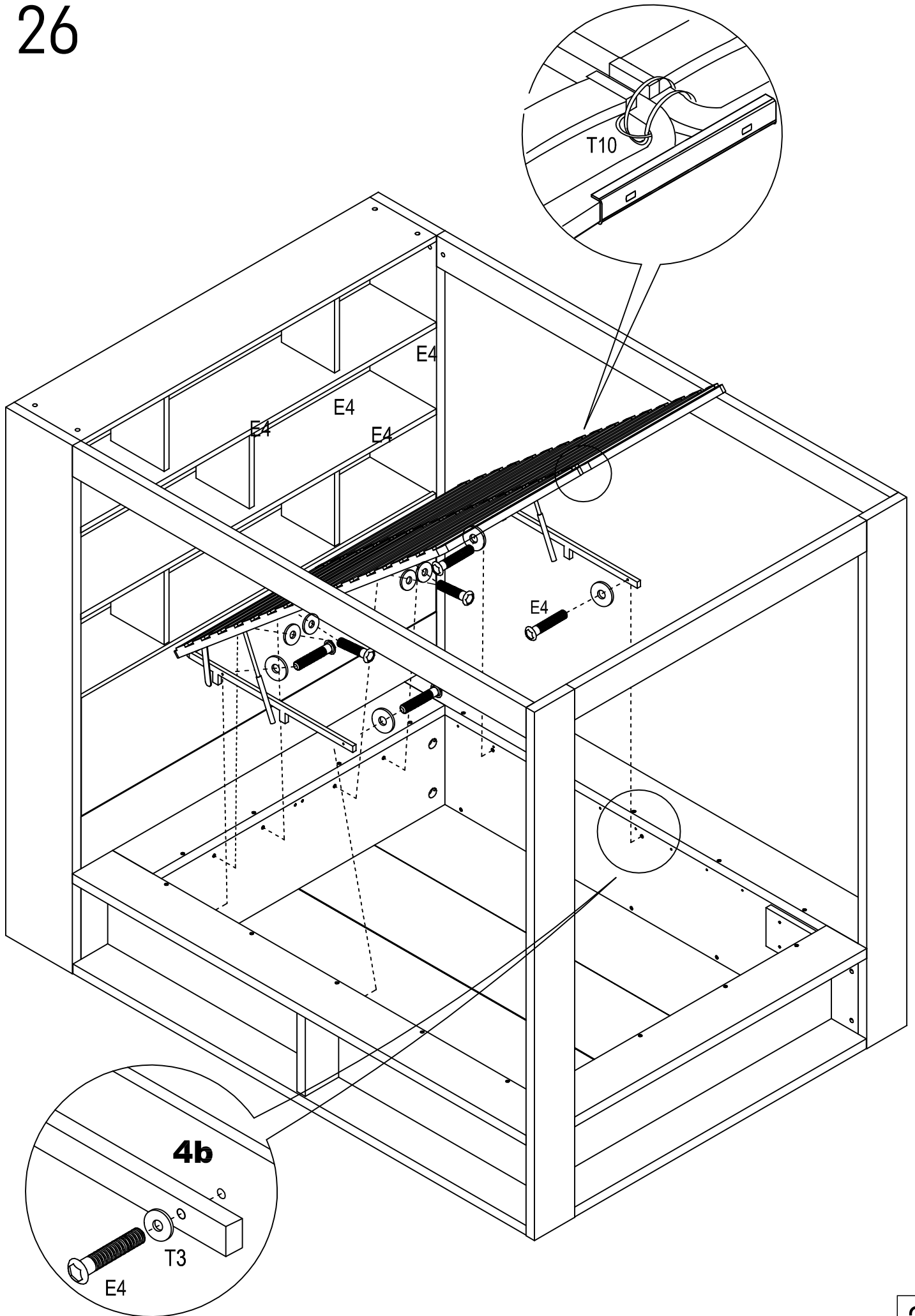

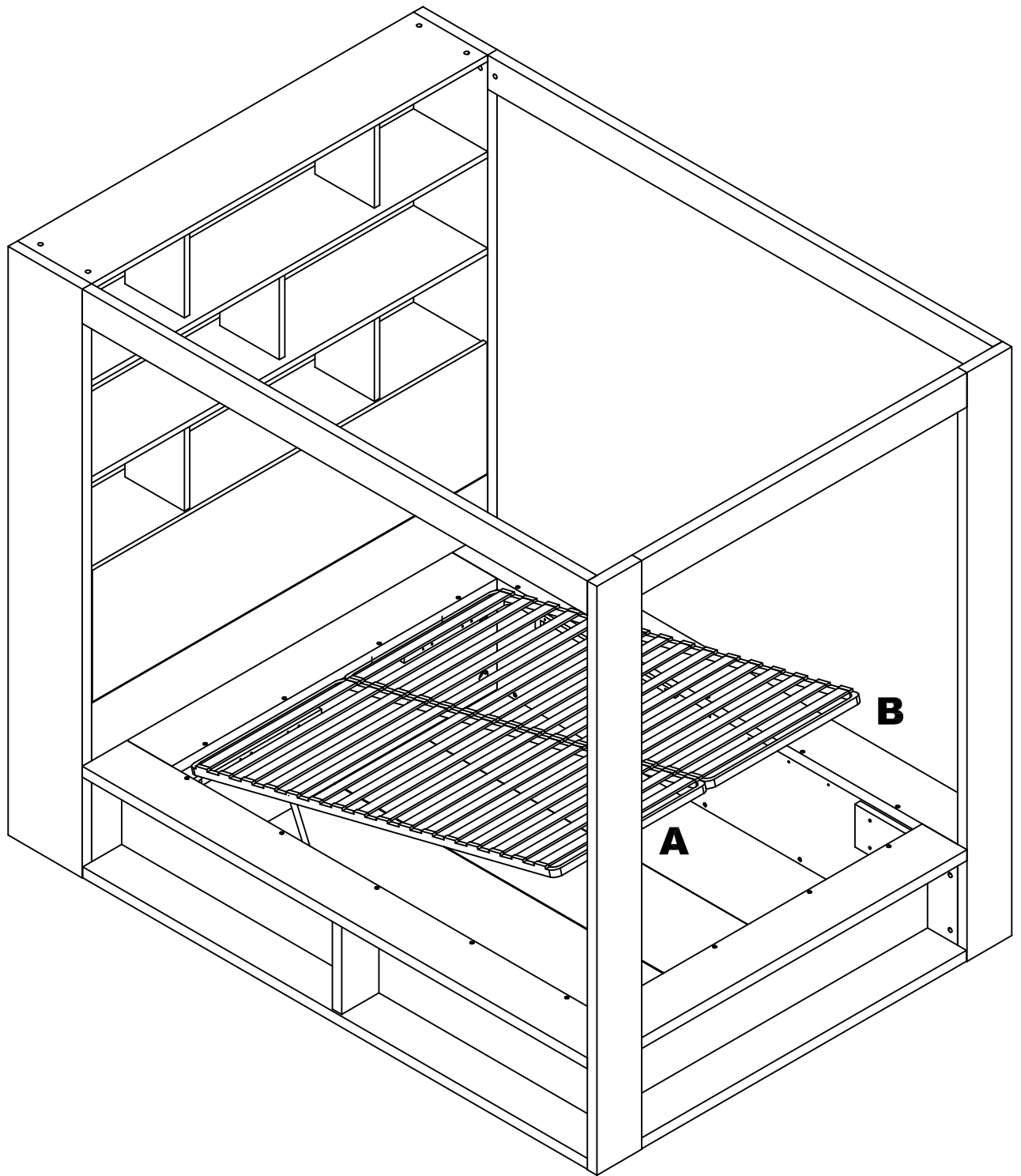

Uwaga! Nieobciążona materacem metalowa rama łóżka wymaga użycia dużej siły, aby ją zamknąć.

Zamknięcie ramy bez materaca grozi samoczynnym jej otwarciem.

Attention! In order to close a metal bed's frame with no mattress inside you need to use appropriate force.

Closing a bed's frame with no mattress inside menaces that it opens automatically.

Achtung! Metallrahmen des Bettes darf nur mit Matratze zugemacht werden.

Внимание! Ненагруженна матрасом металлическая рама требует использования большой силой, чтобы ее закрыть.

Закрытие рамы без матраса грозит ее самодействующим открытием.

28

UWAGA! Montaż elementu do dokupienia!

ACHTUNG! Die Montages des Zukaufelementes!

ATTENTION! Assembling of the element to be bought in addition!

ВНИМАНИЕ! Монтаж элемента для докупки

