

# ASSEMBLY INSTRUCTION

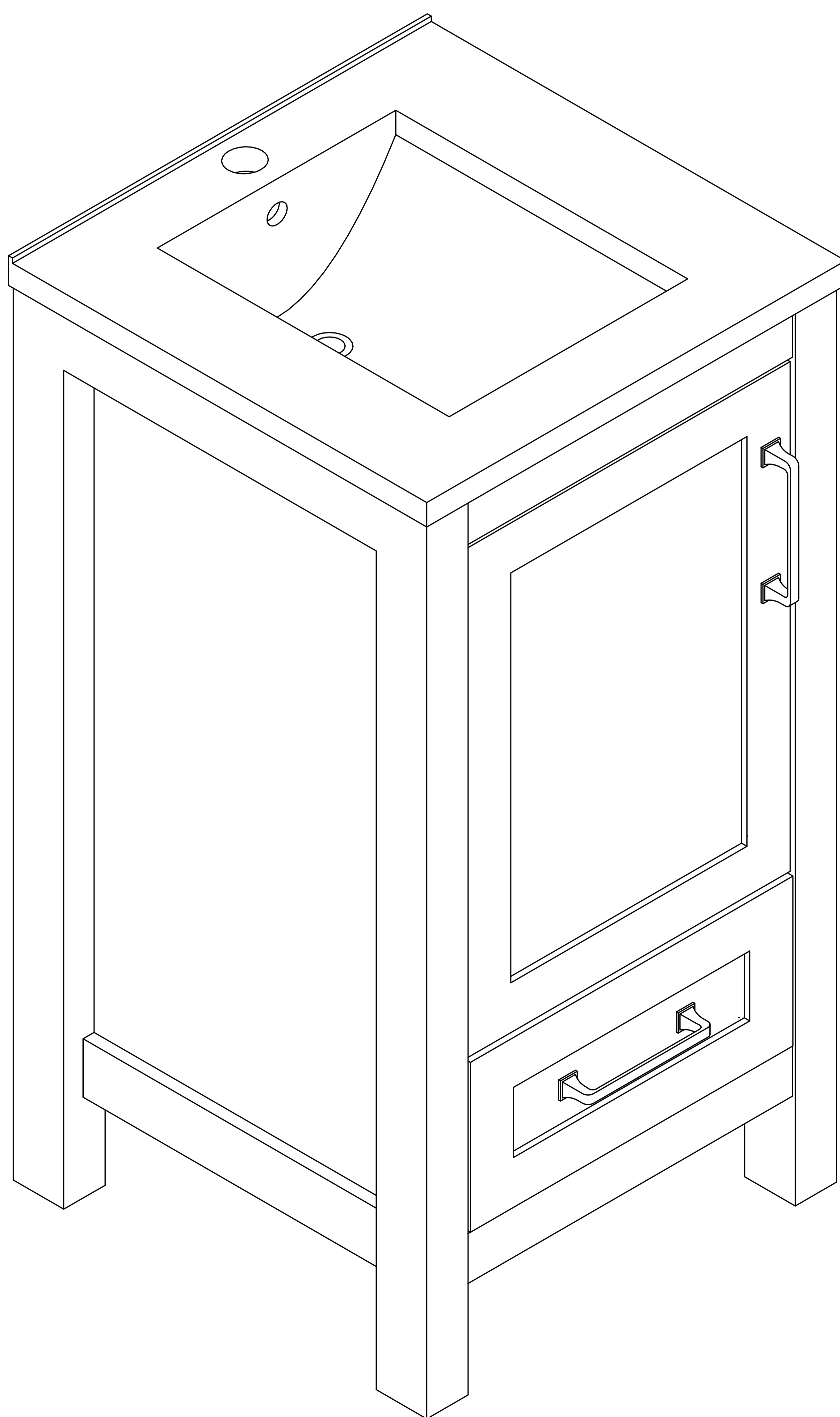

# IMPORTANT NOTICE

## **Workspace Safety**

Keep the workspace clear of clutter and ensure it's well-lit. A clean, flat surface is essential.

## **Read Instructions**

Read the entire assembly guide before starting. Skipping steps can compromise safety.

## **Use Proper Tools**

Use the tools provided or recommended. Avoid overtightening screws.

## **Secure Furniture**

Use the tools provided or recommended. Avoid overtightening screws.

## **Handle Small Parts**

Keep small parts away from children and pets to avoid choking hazards.

## **Get Help**

Don't hesitate to ask for help with heavy or complex pieces.

## **Inspect Regularly**

Periodically check for loose screws or wobbly parts and tighten as needed.

Follow these tips for a safe assembly process.

# CARE AND CLEANING

Many cleaners contain abrasive and chemical substance which is not suitable for cleaning stainless steel, enamel, plating or plastic products. You may use mild cleansers or soaps to clean the surfaces. Wipe any splashes of cleaner solutions from the surface with a clean soft cloth.

Maintain ventilation in the bathroom and separate the dry area from the damp one if conditions permit. Try to open the door and windows of the bathroom to maintain adequate ventilation.

This cabinet is built to withstand normal bathroom humidity. For best results, keep this vanity dry and take necessary steps to minimize bathroom humidity by opening windows and doors and using the exhaust fan (if available).

To maintain the cabinet door, clean and wipe the door regularly with a soft cloth. Wipe condensation with a dry, soft cloth. Keep away from high temperatures.

Please do not sit, lean or step on the basin cabinet.

# ASSEMBLY DIAGRAM

1. Refer to the exploded view below for the approximate location of each component.
2. Each part is labeled for easy identification.
3. Follow the assembly instructions carefully to ensure proper installation.

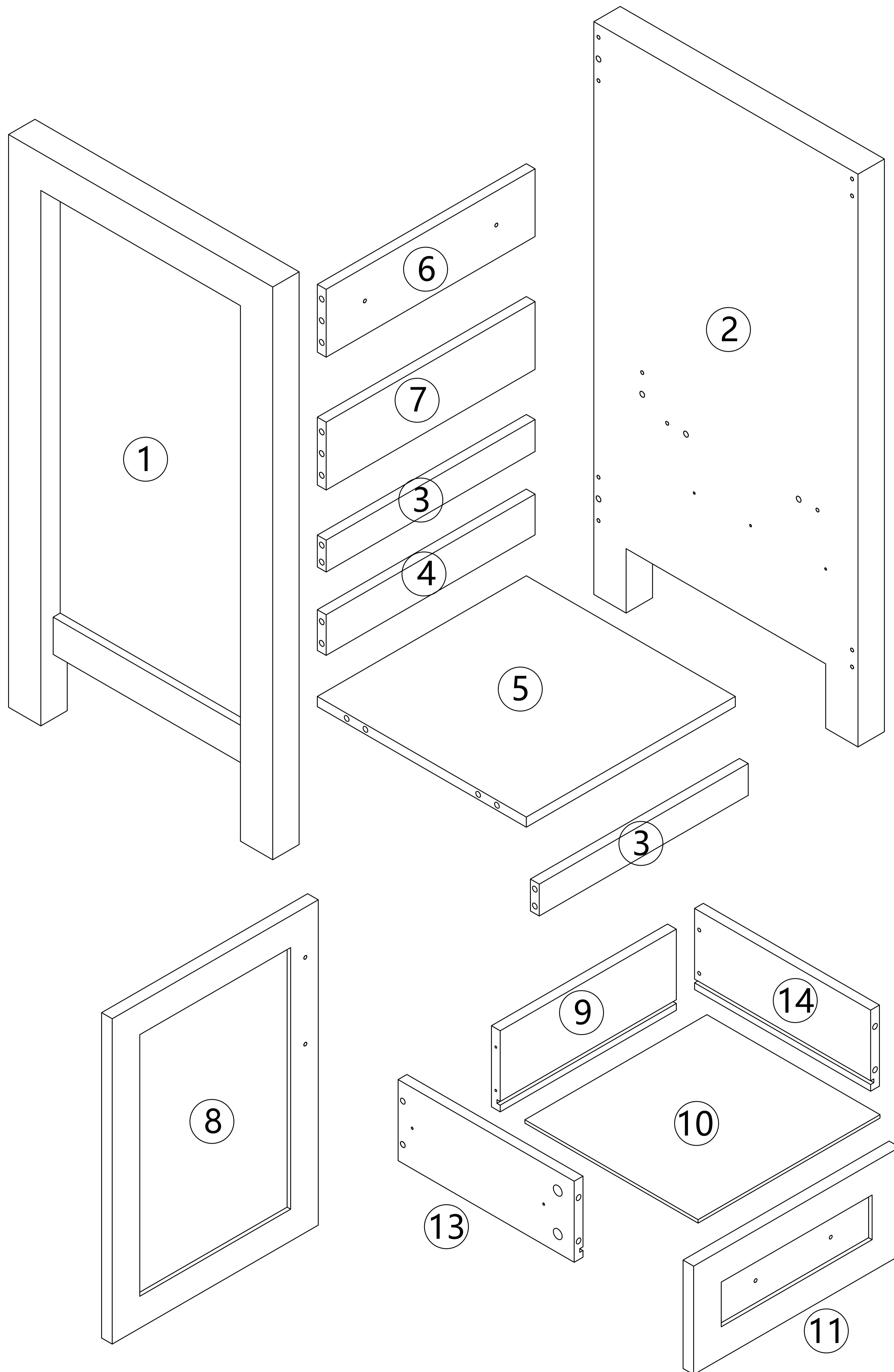



# PRE-ASSEMBLY PREPARATION

Before assembly, place all furniture parts on a soft surface, such as a blanket or the original packaging cardboard, to prevent damage to the floor or components from accidental drops and to avoid scratching the surfaces.

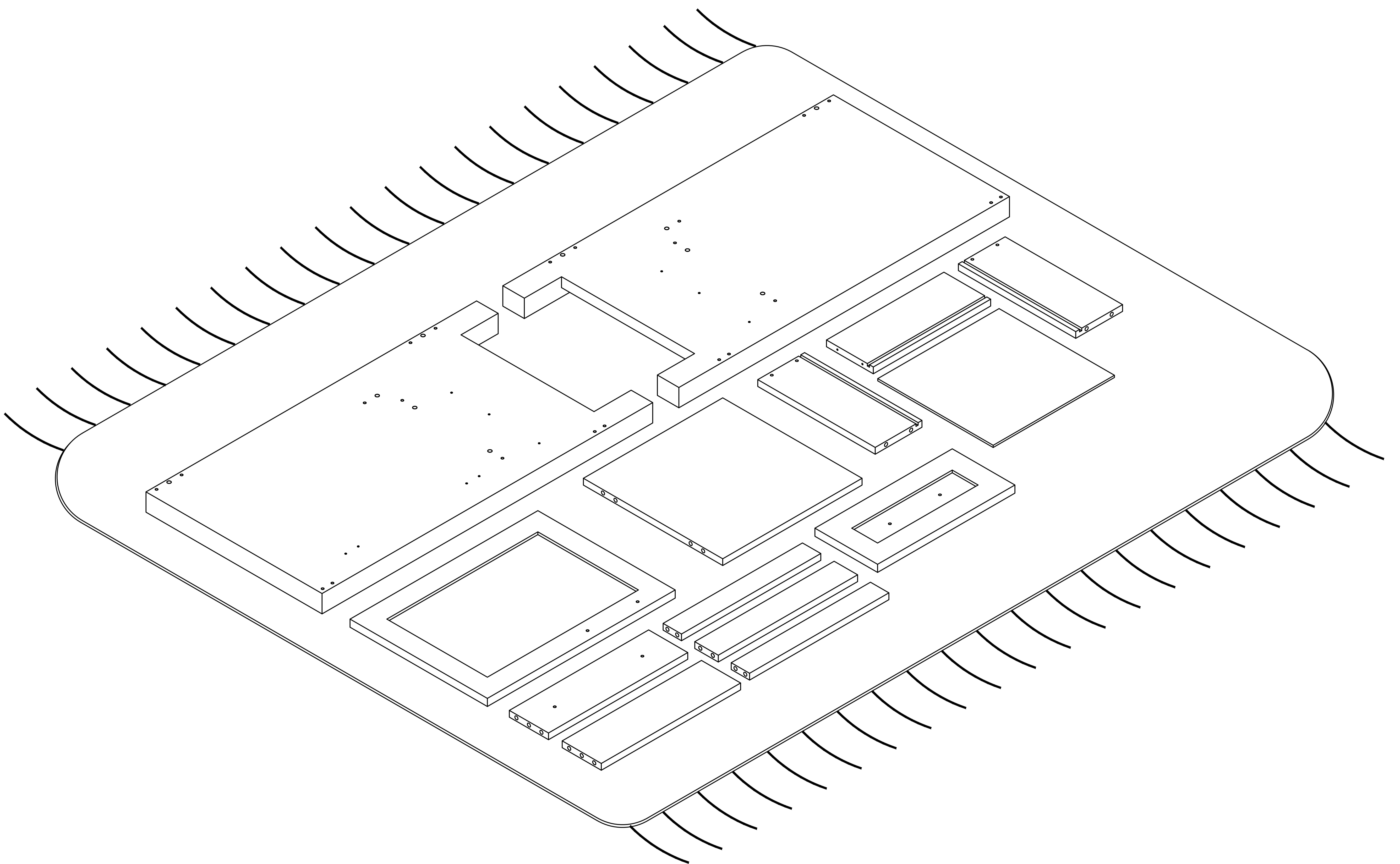

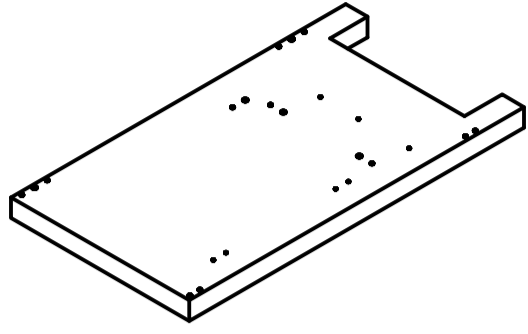
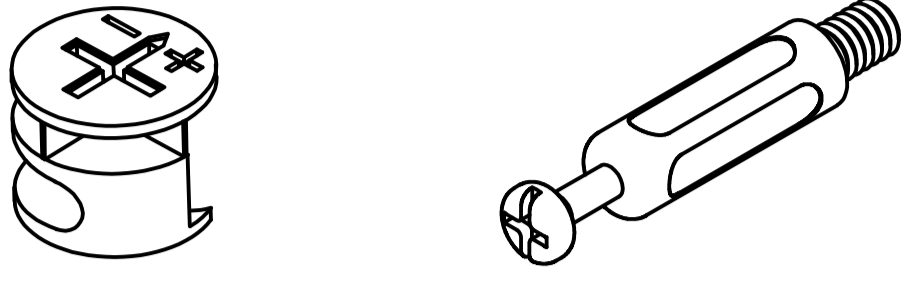
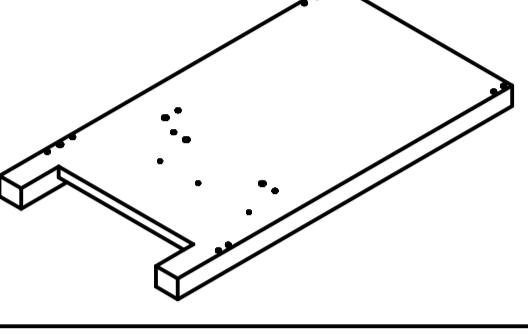
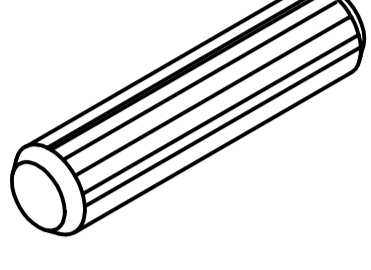
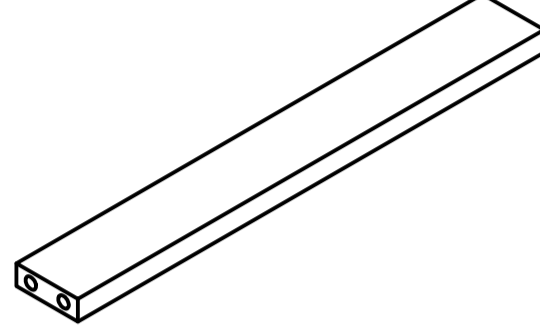
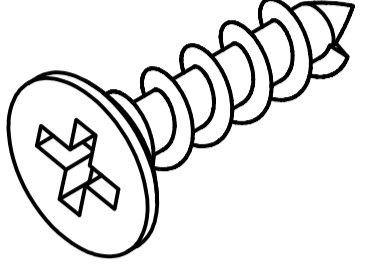
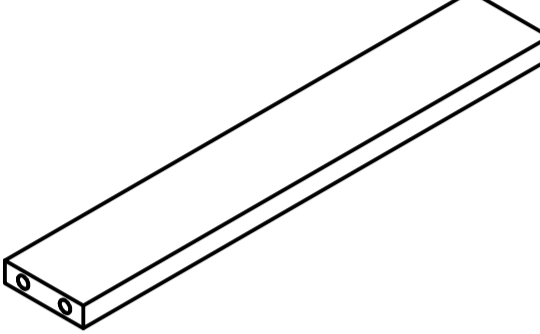
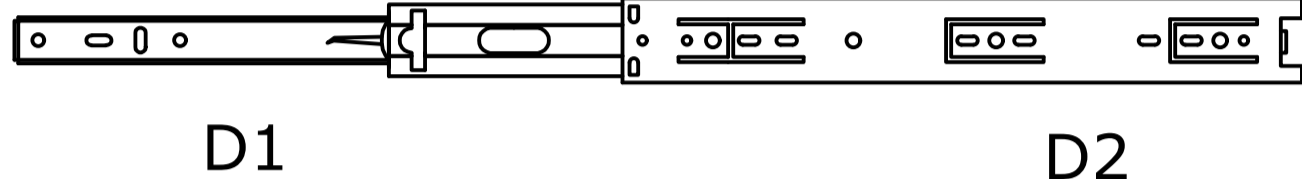
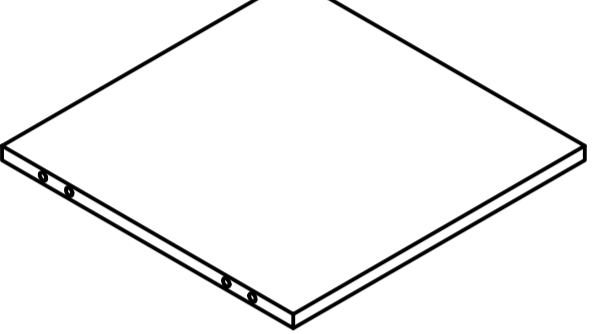
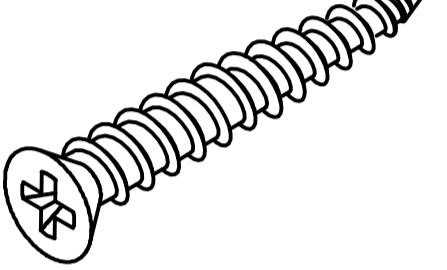
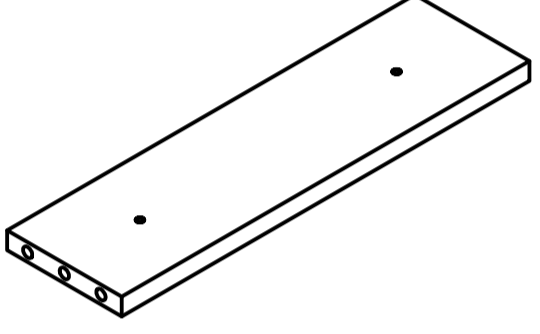
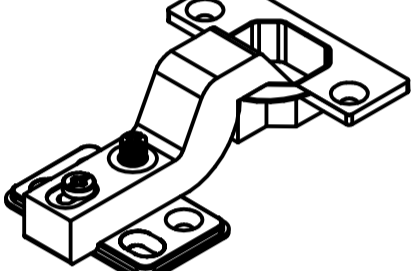
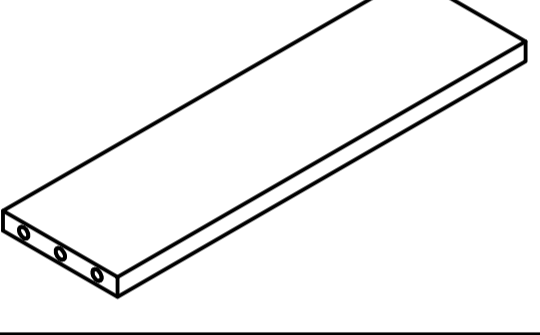
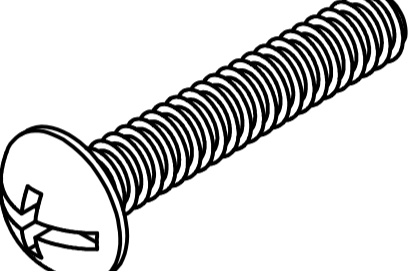
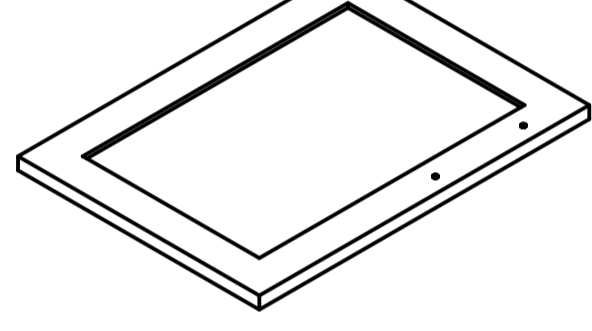
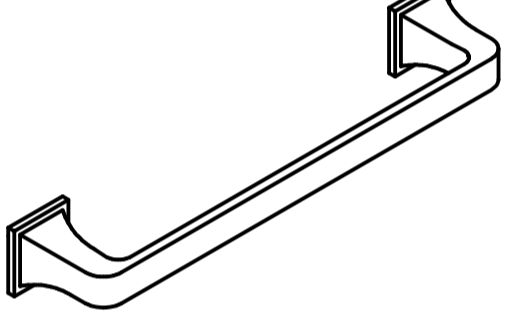
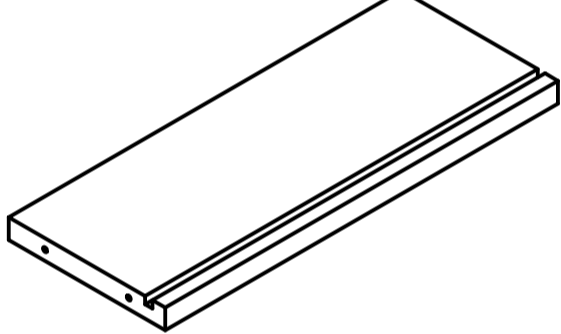
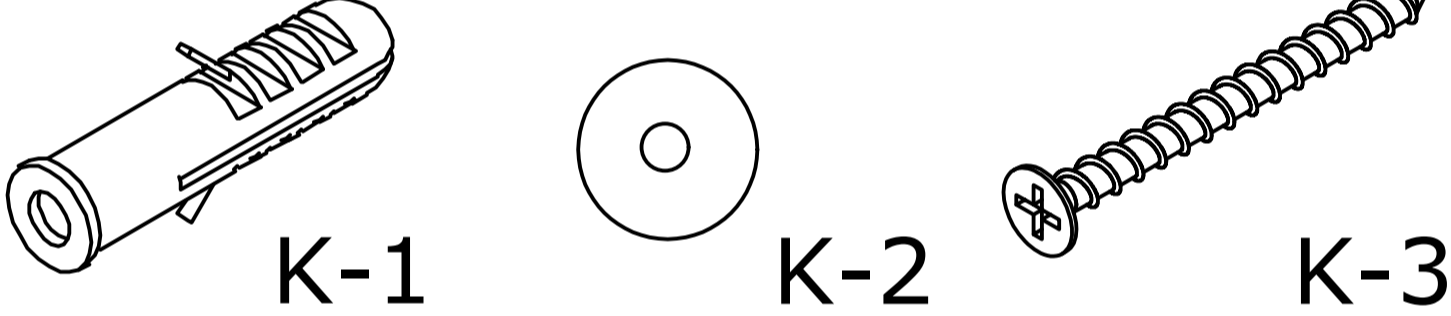
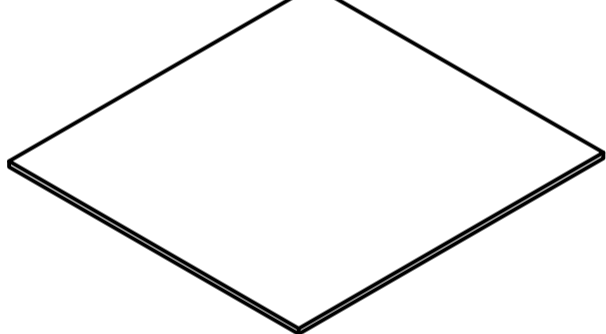
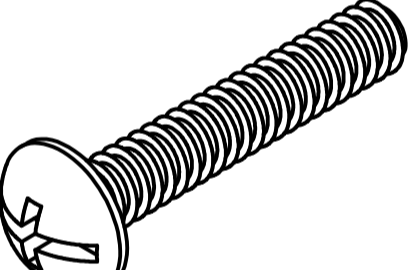
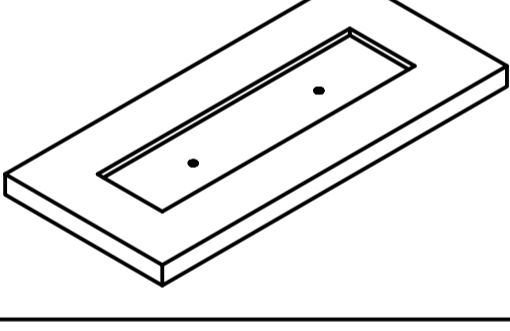
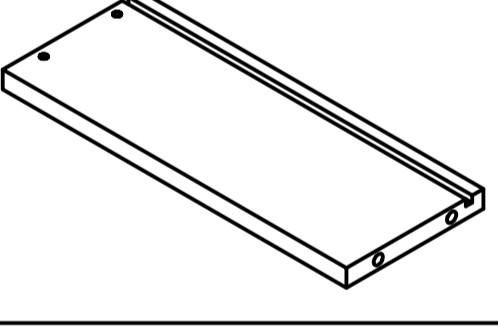
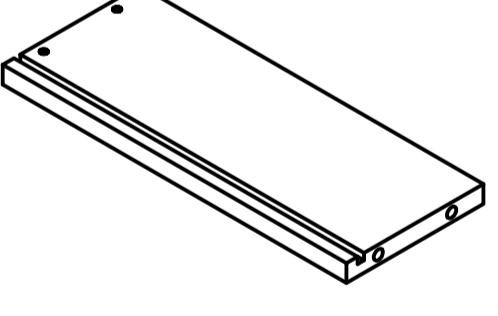
PARTS LIST			HARDWARE LIST		
NO.	Description	QTY	NO.	Description	QTY
1		1	A		26
2		1	B	 Ø 8 x 30 mm	10
3		2	C	 Ø 4 x 14 mm	22
4		1	D	 D1 D2	2
5		1	F	 Ø 4 x 30 mm	4
6		1	G		2
7		1	H	 Ø 4 x 22 mm	2
8		1	J		2
9		1	K	 K-1 K-2 K-3	2
10		1	L	 Ø 4 x 18 mm	2
11		1			
13		1			
14		1			

**CAUTION:** Please confirm the parts list before installtion

## YOU MAY NEED (NOT SUPPLIED)

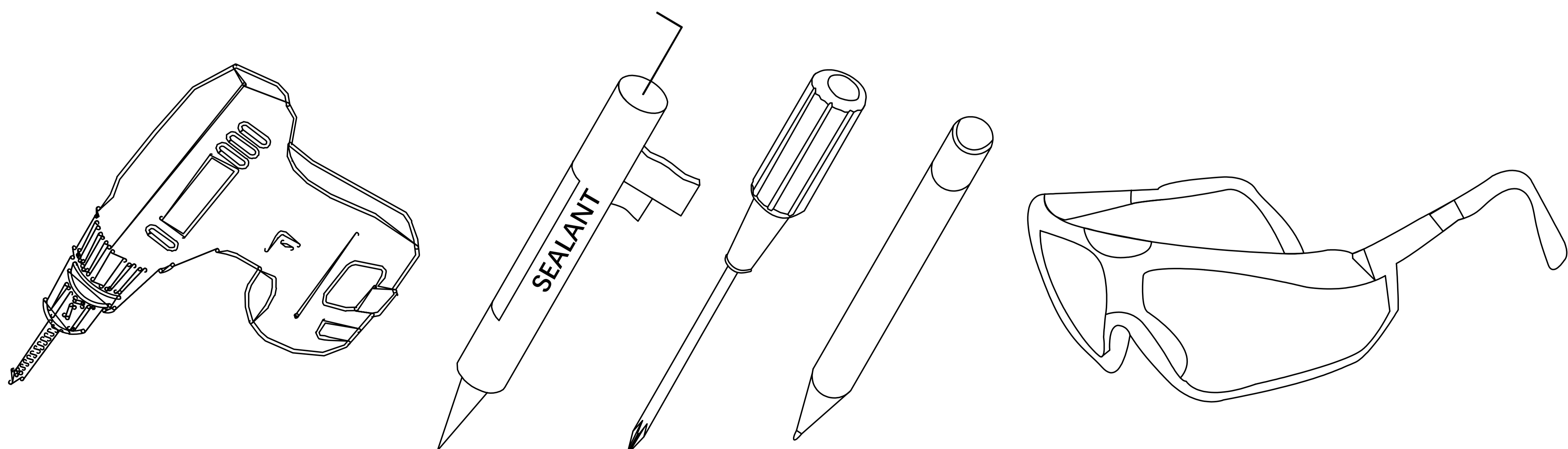

# 1

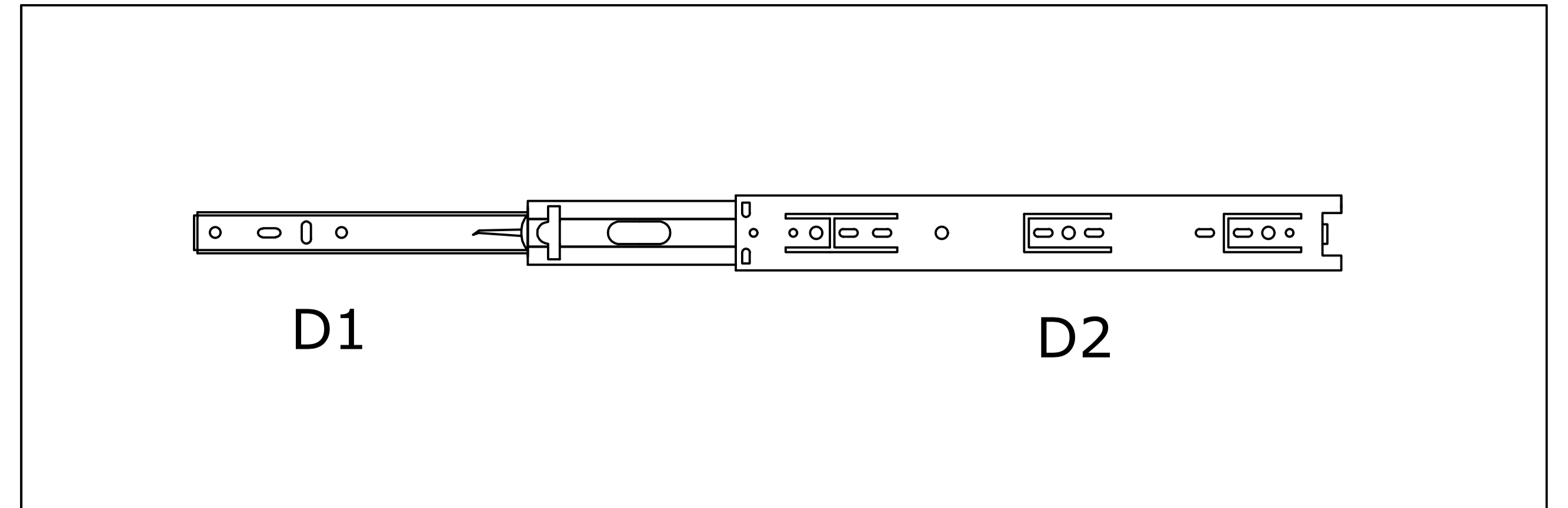

## TIPS

### How To Separate A Ball Bearing Slider

1) Pull toward arrow to open the slider until it's stops and then flip it over

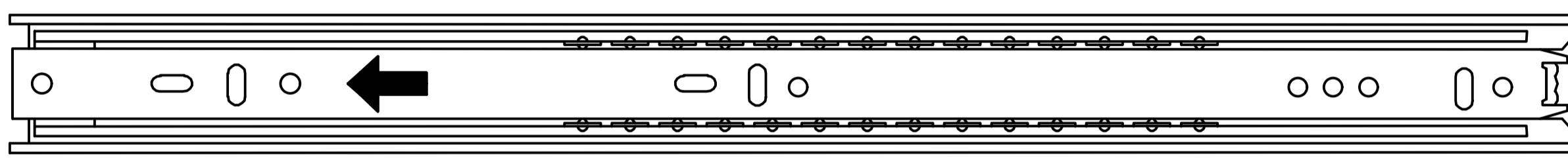

2) Push plastic lever down and pull apart the slider at the same time

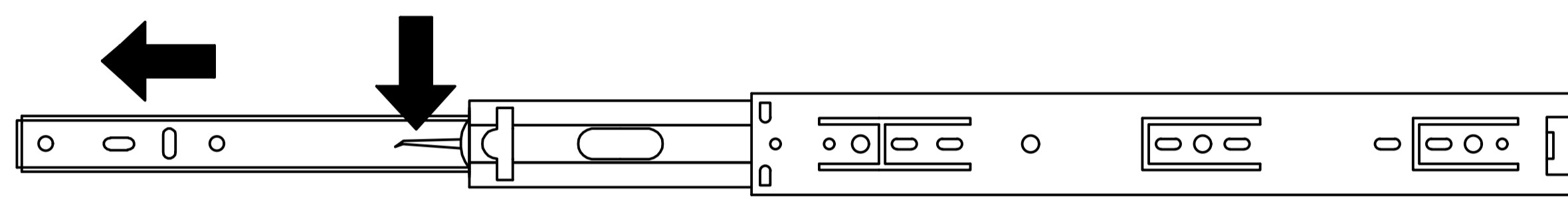

3) After disassembly

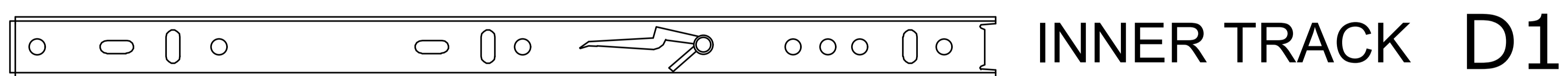
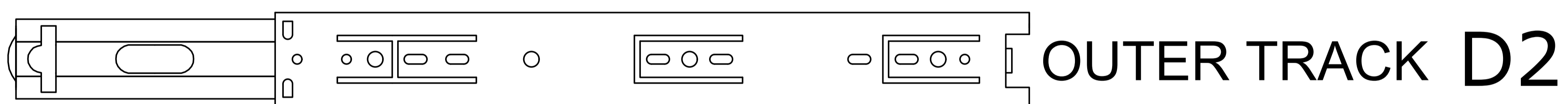

### How to Assemble the Slider

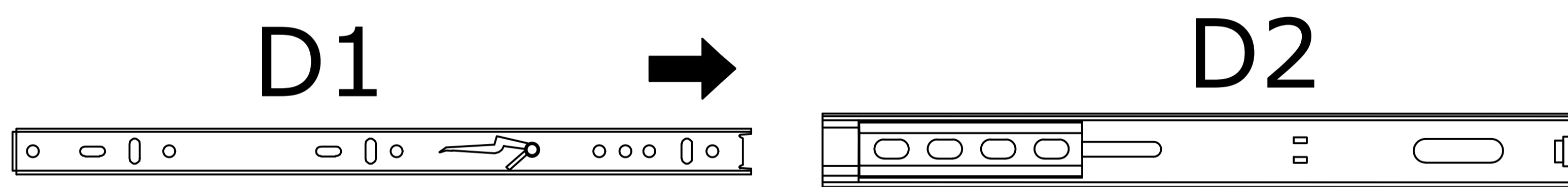

Align the outer track(L2) with the center of the inner track(L1) and push in.

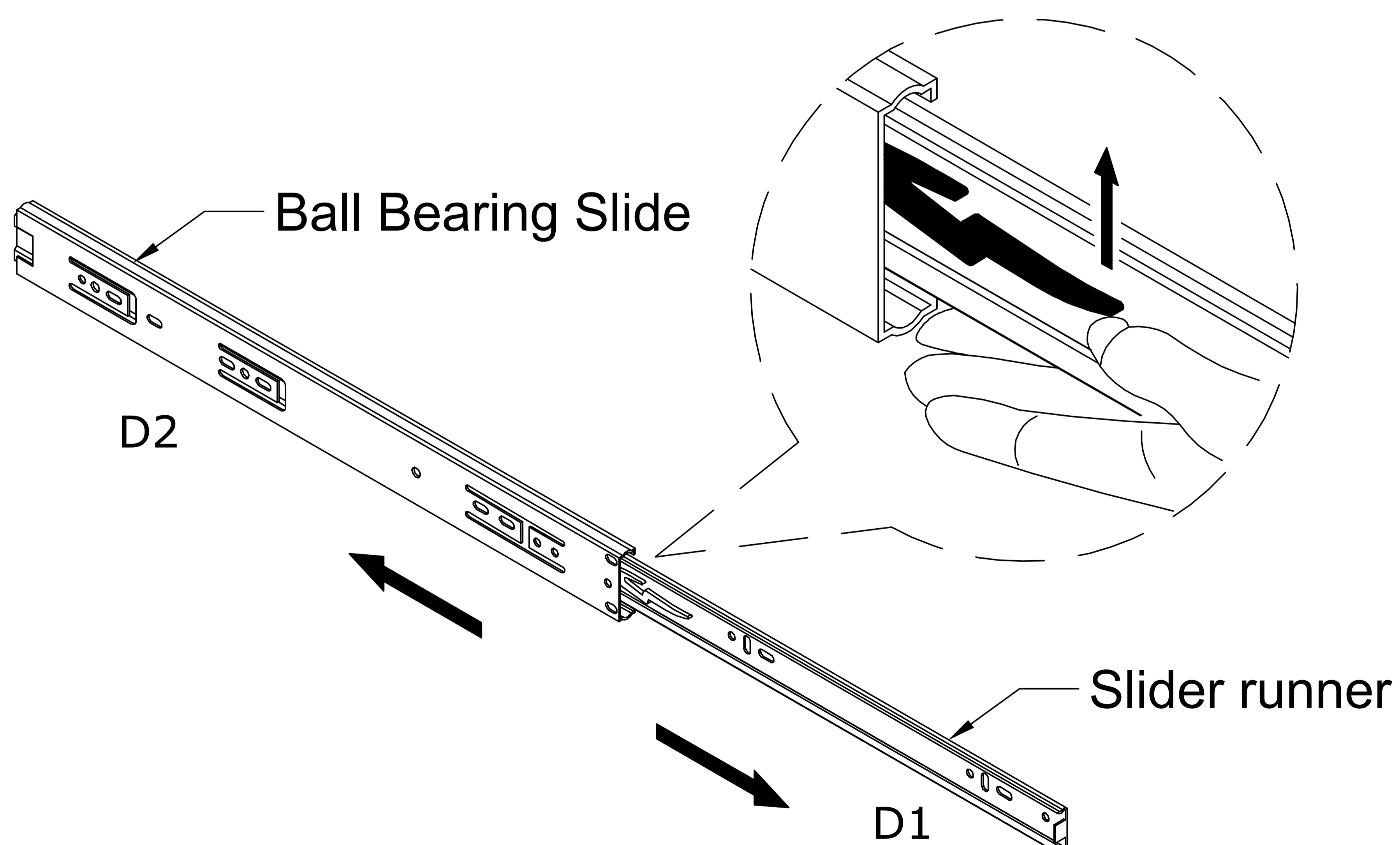

# 2

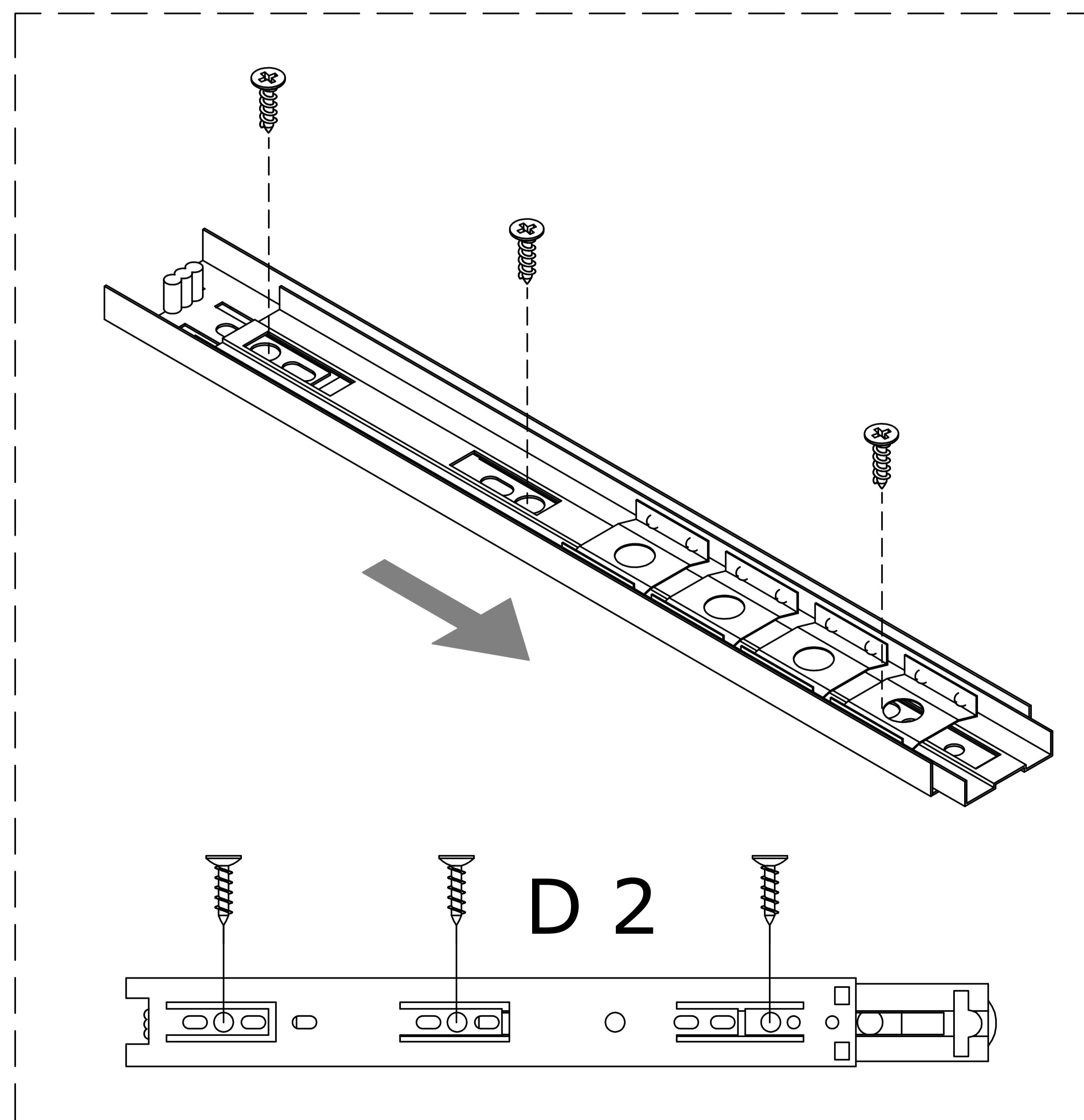
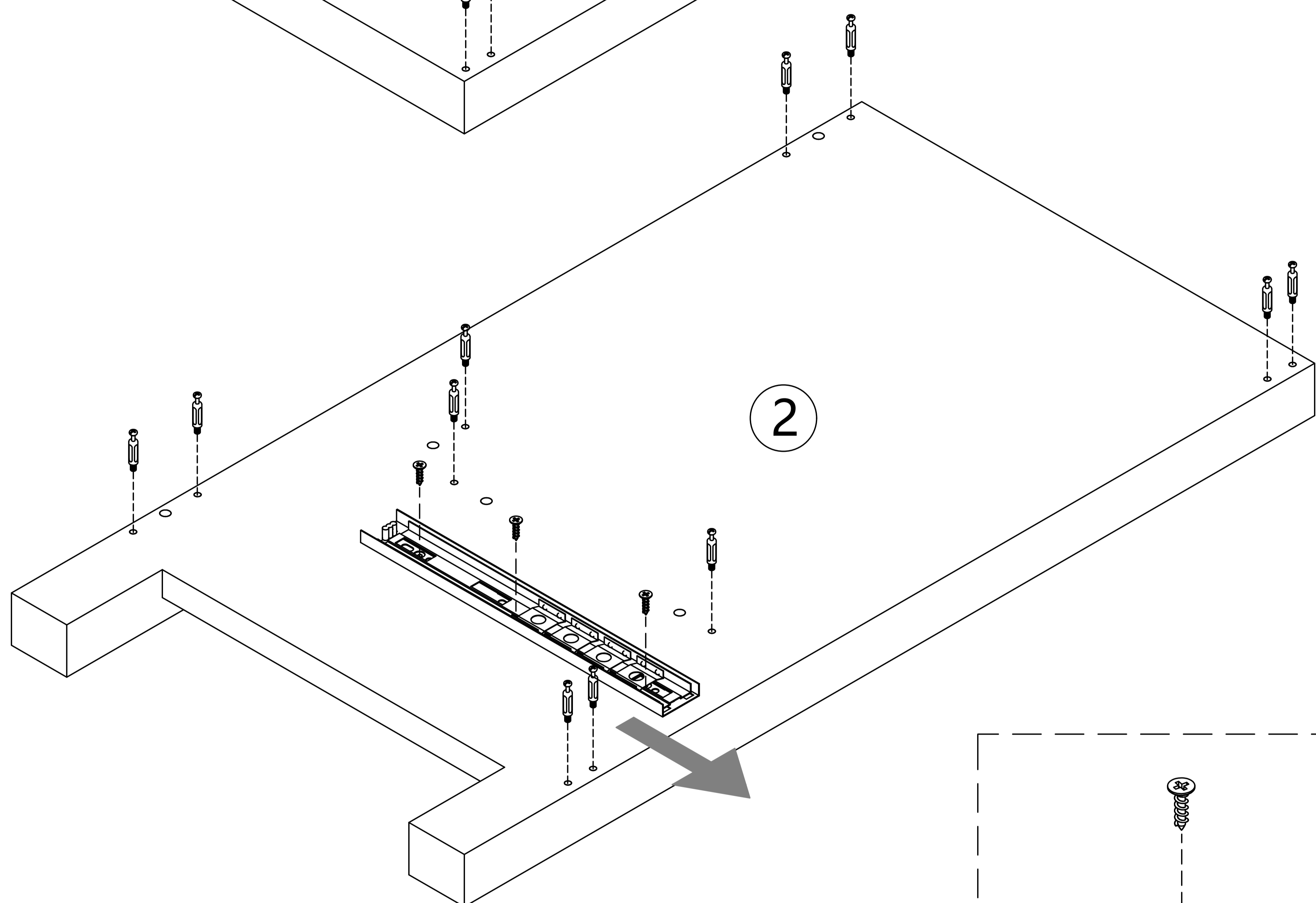
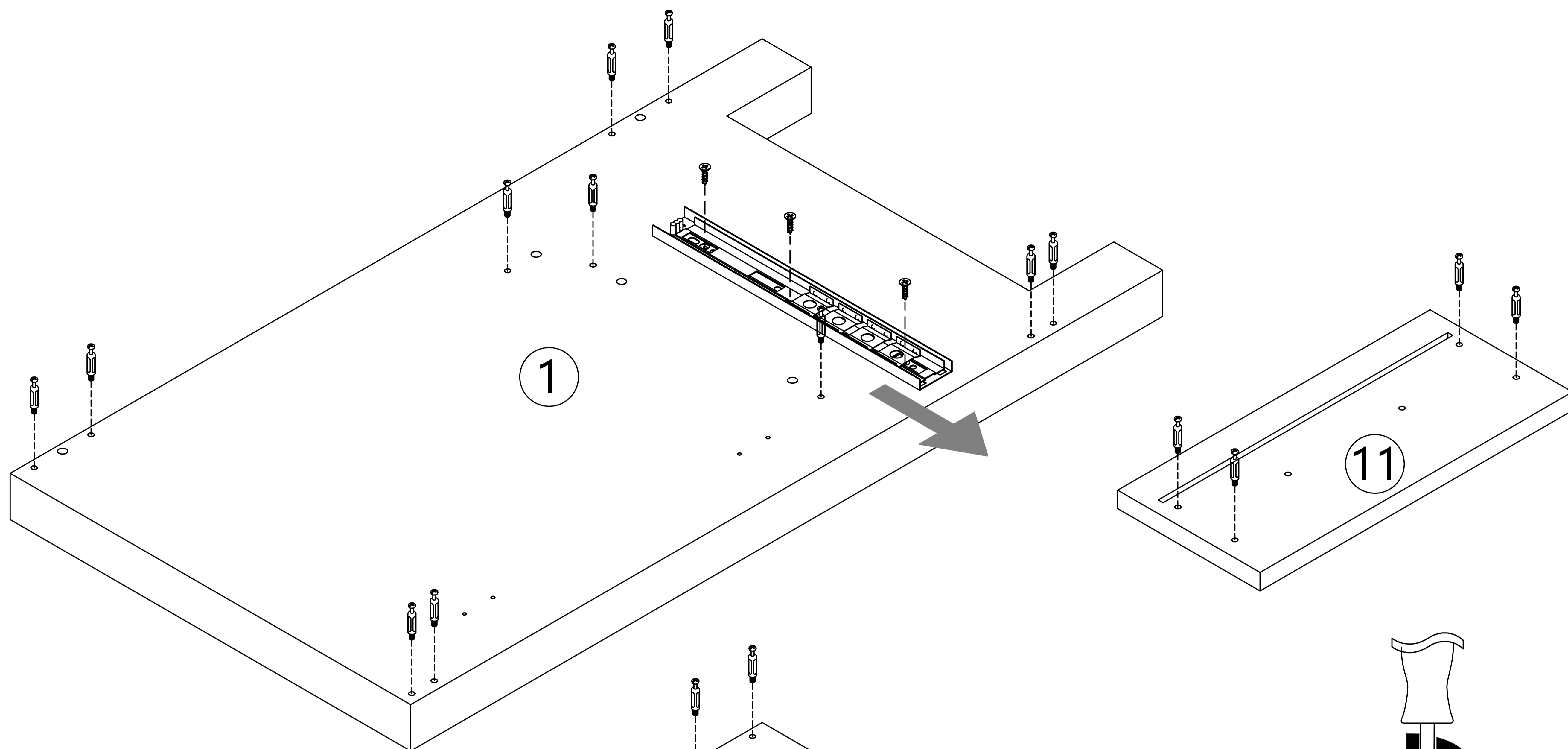
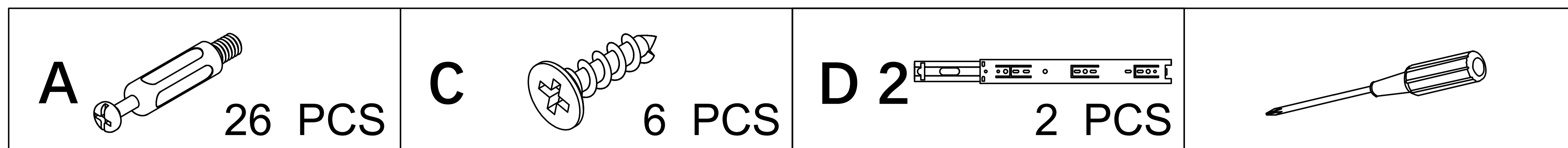

First, secure the first hole position with a screw, then move the slide rail to fasten the second and third hole positions.

- Install screw rod (A) and secure slide rail (D2) with screw (C).

# 3

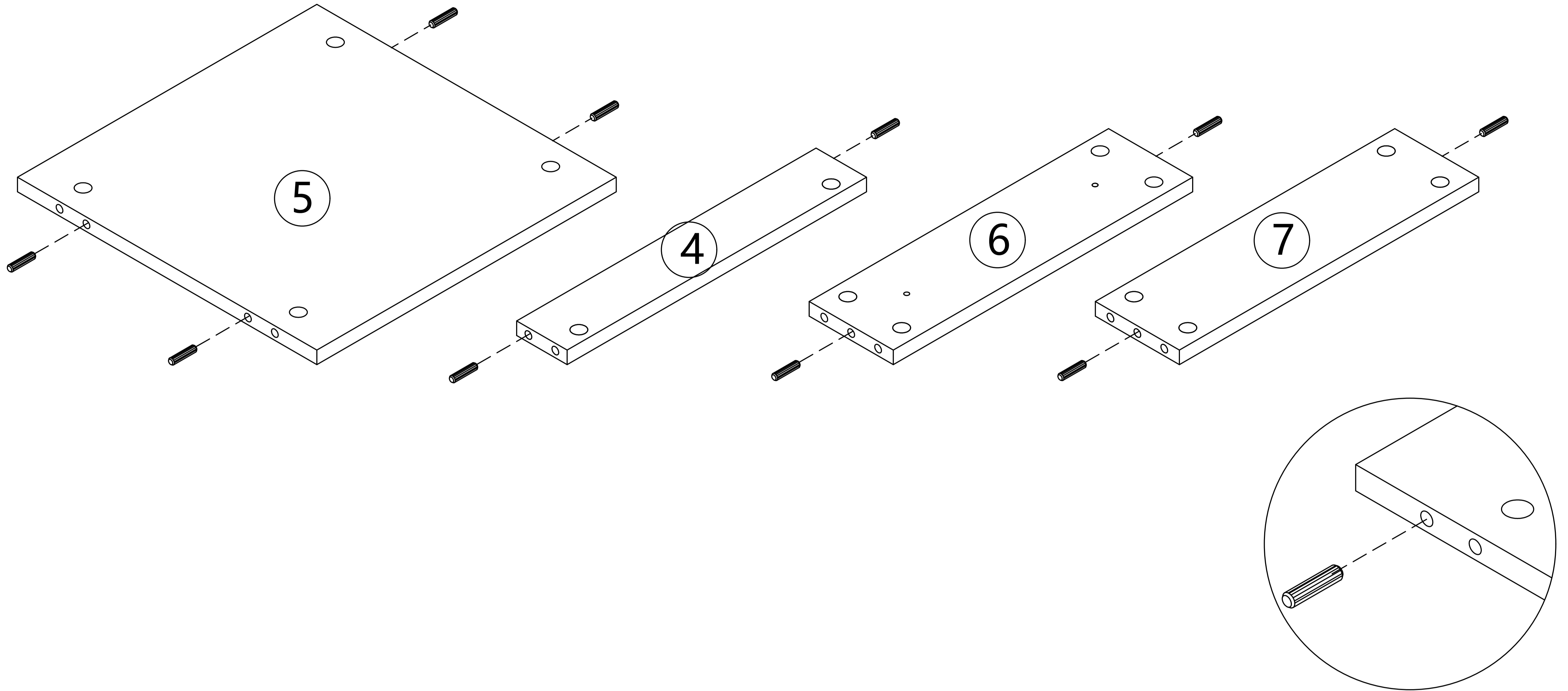

- Insert wooden rod (B).

# 4

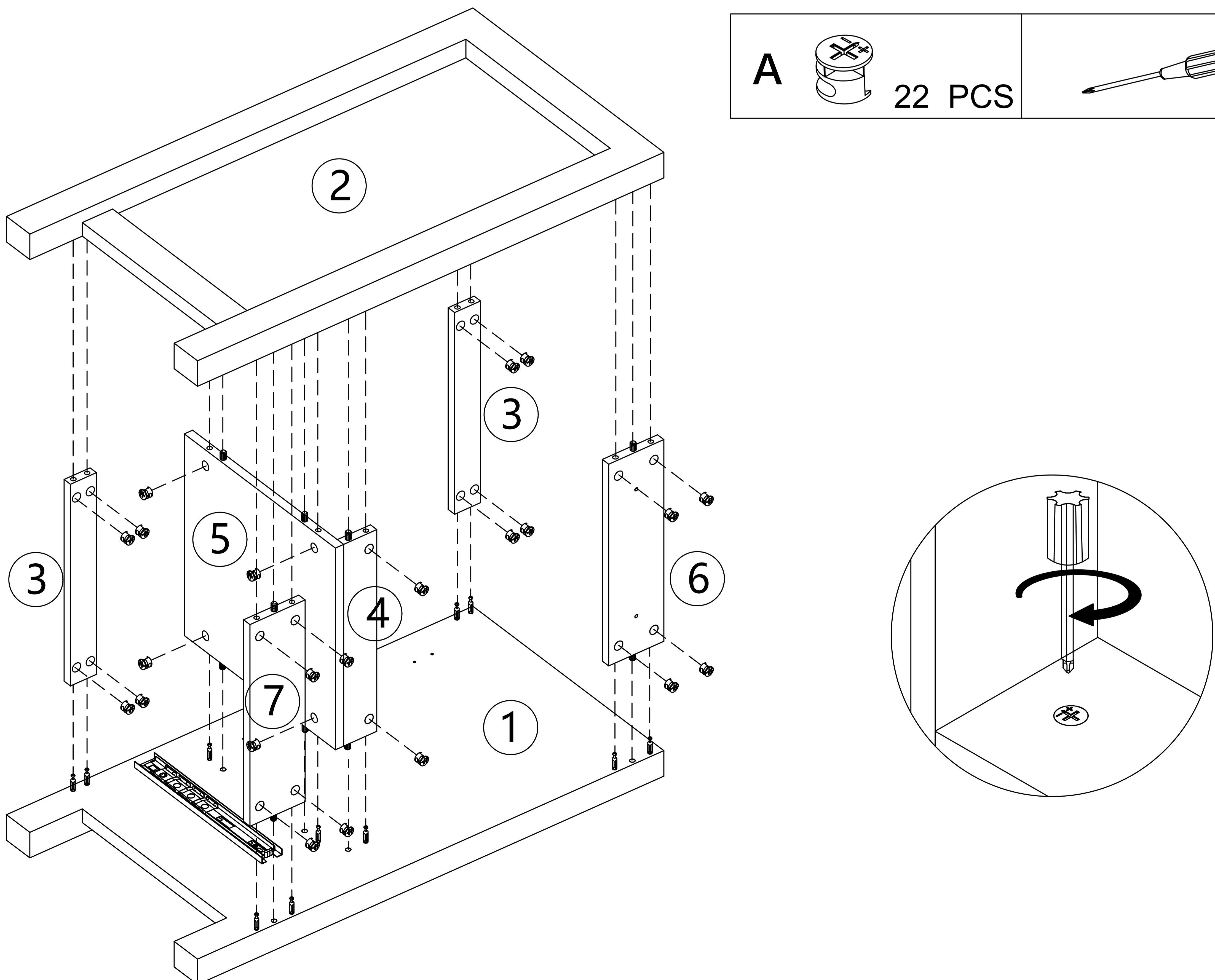
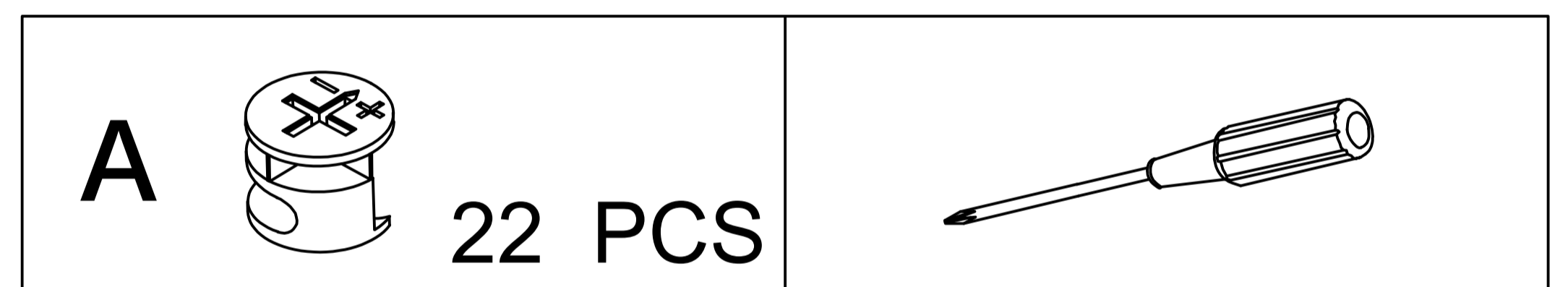

- Refer to the illustration to butt-joint the plates and fasten them securely with cam lock (A).

# 5

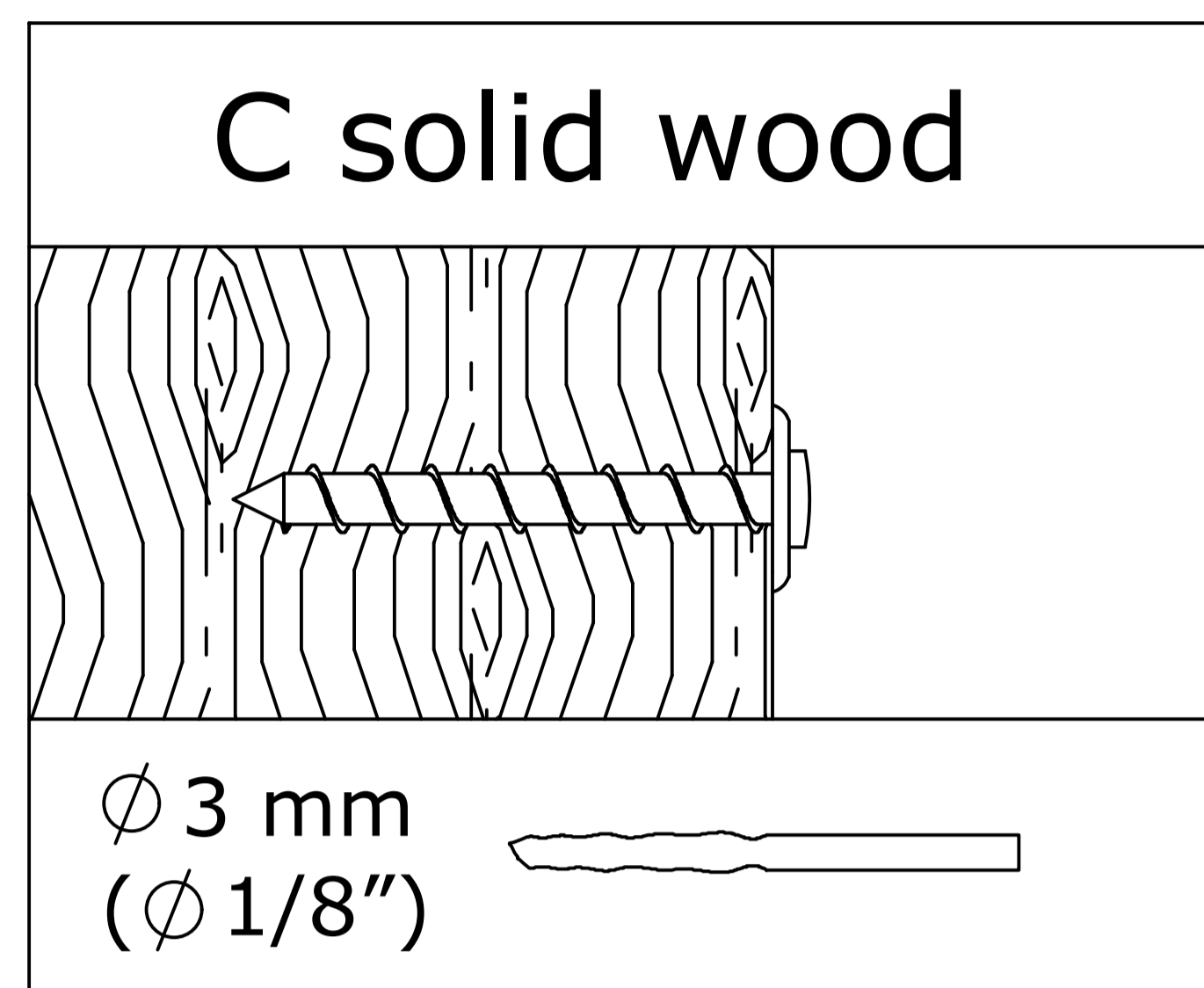
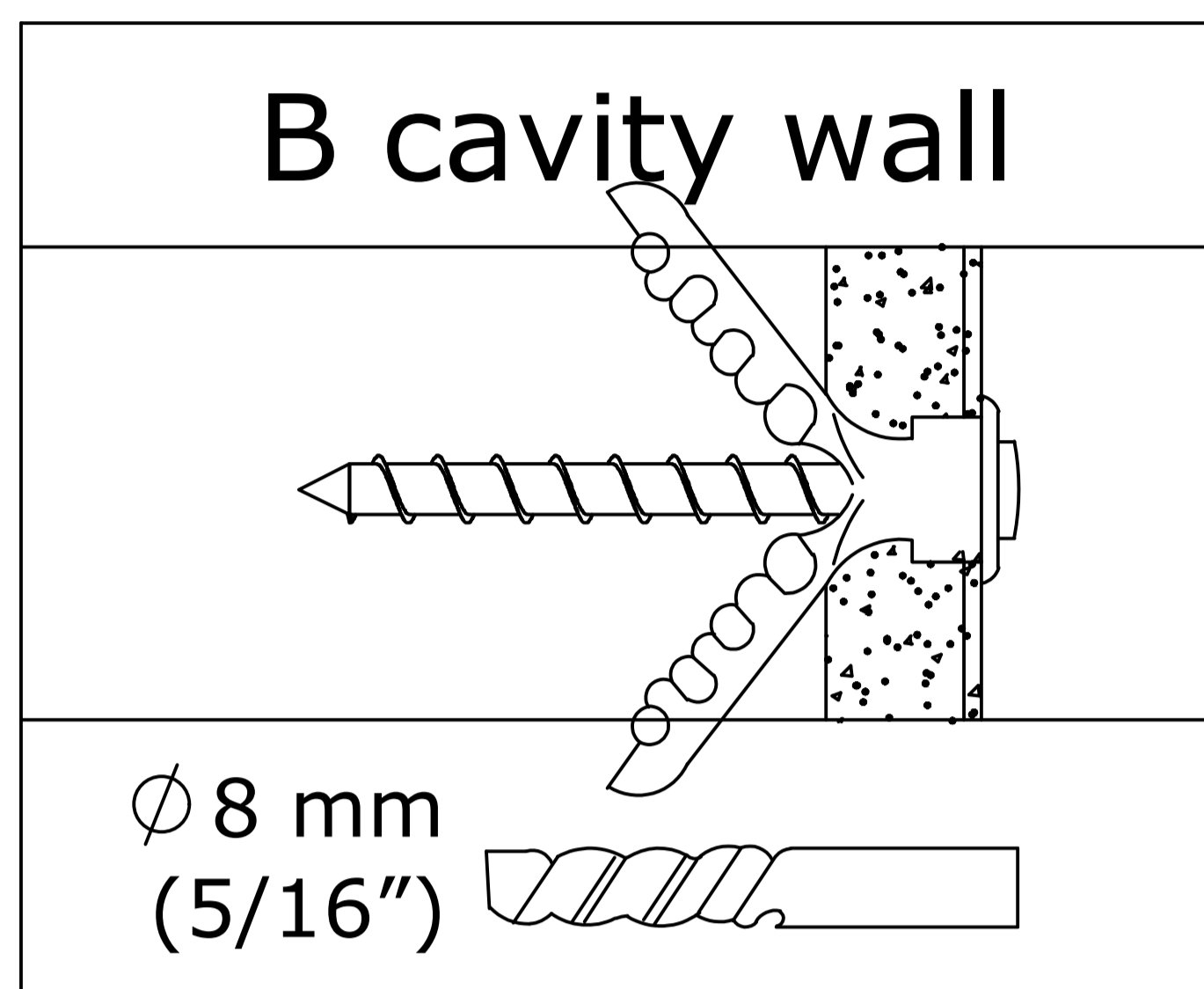
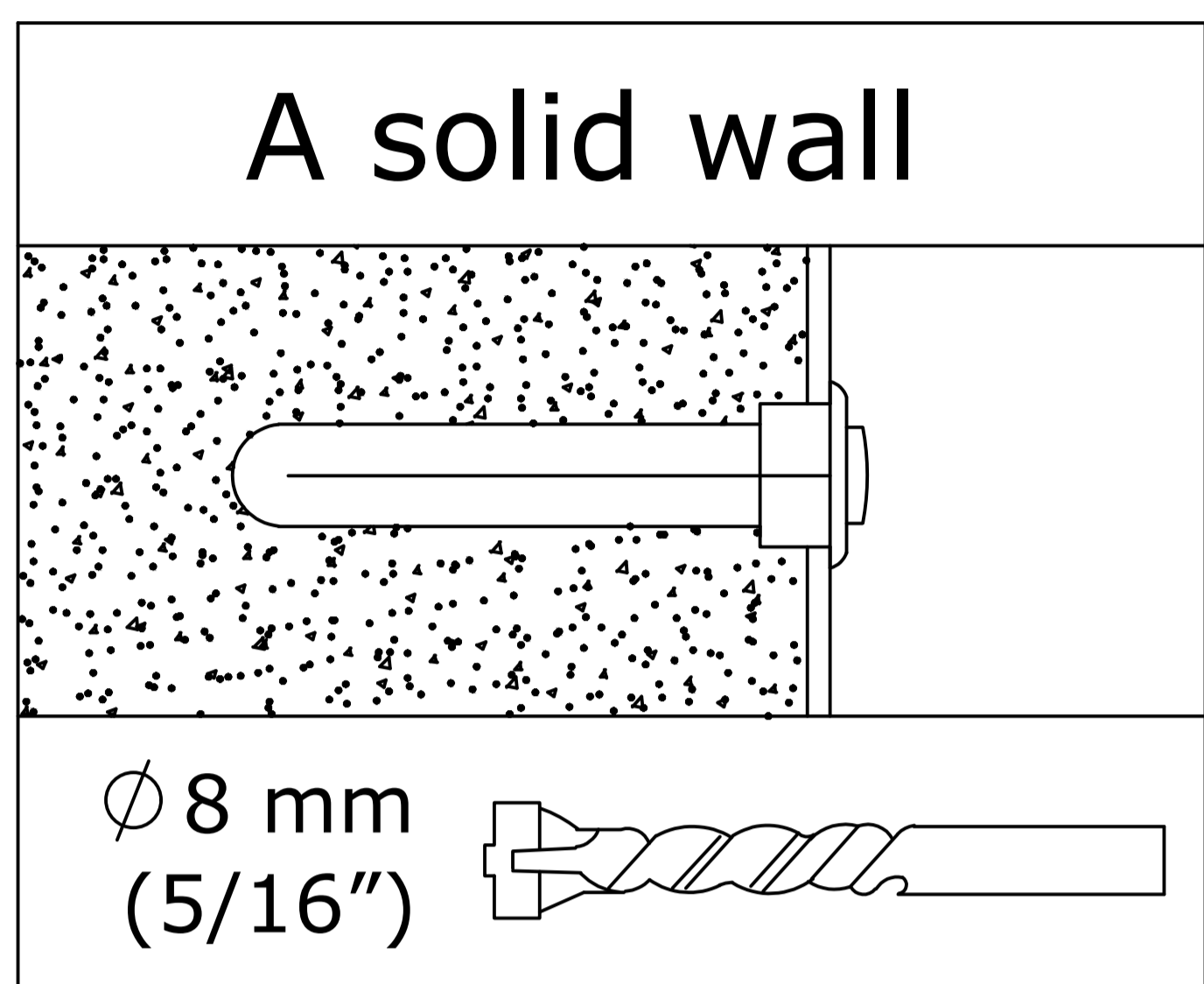
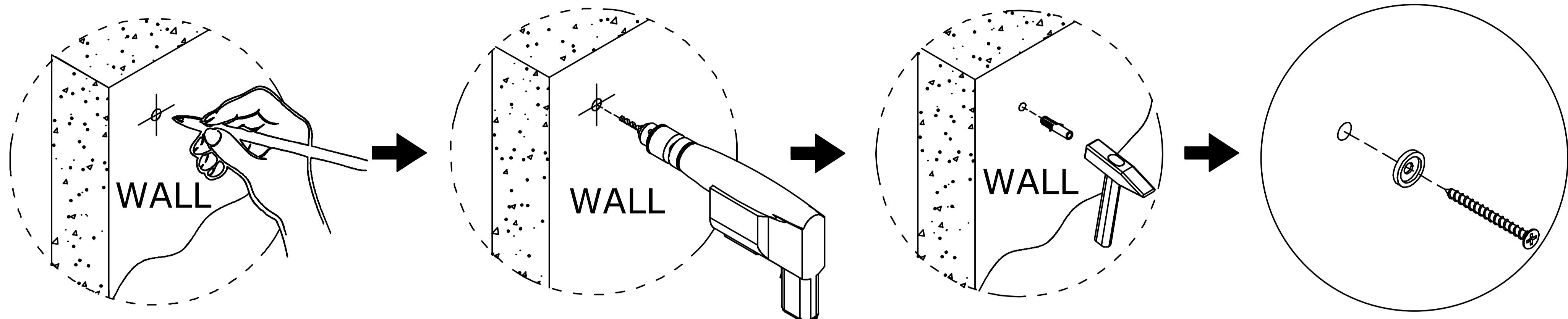
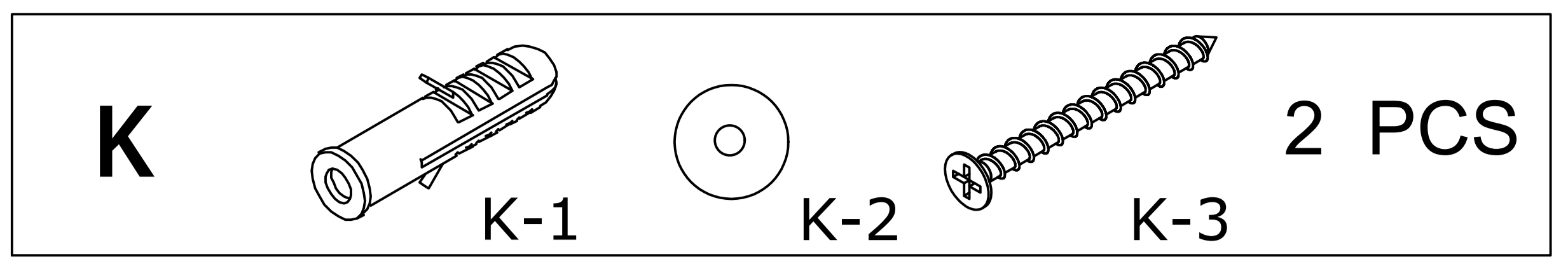

**Warning:** If you overturn the furniture, it may cause serious or fatal crushing injuries. We have a wall connection device attached, please use it to hold the furniture following these instructions.

1. Mark the corresponding hole positions where you want to place the furniture;
2. Use a impact drill to drill holes and pay attention to avoid wires and water pipes;
3. Knock the expansion pipes in to the wall holes;
4. Place the furniture in the corresponding position and tighten the wall connection device with screws.

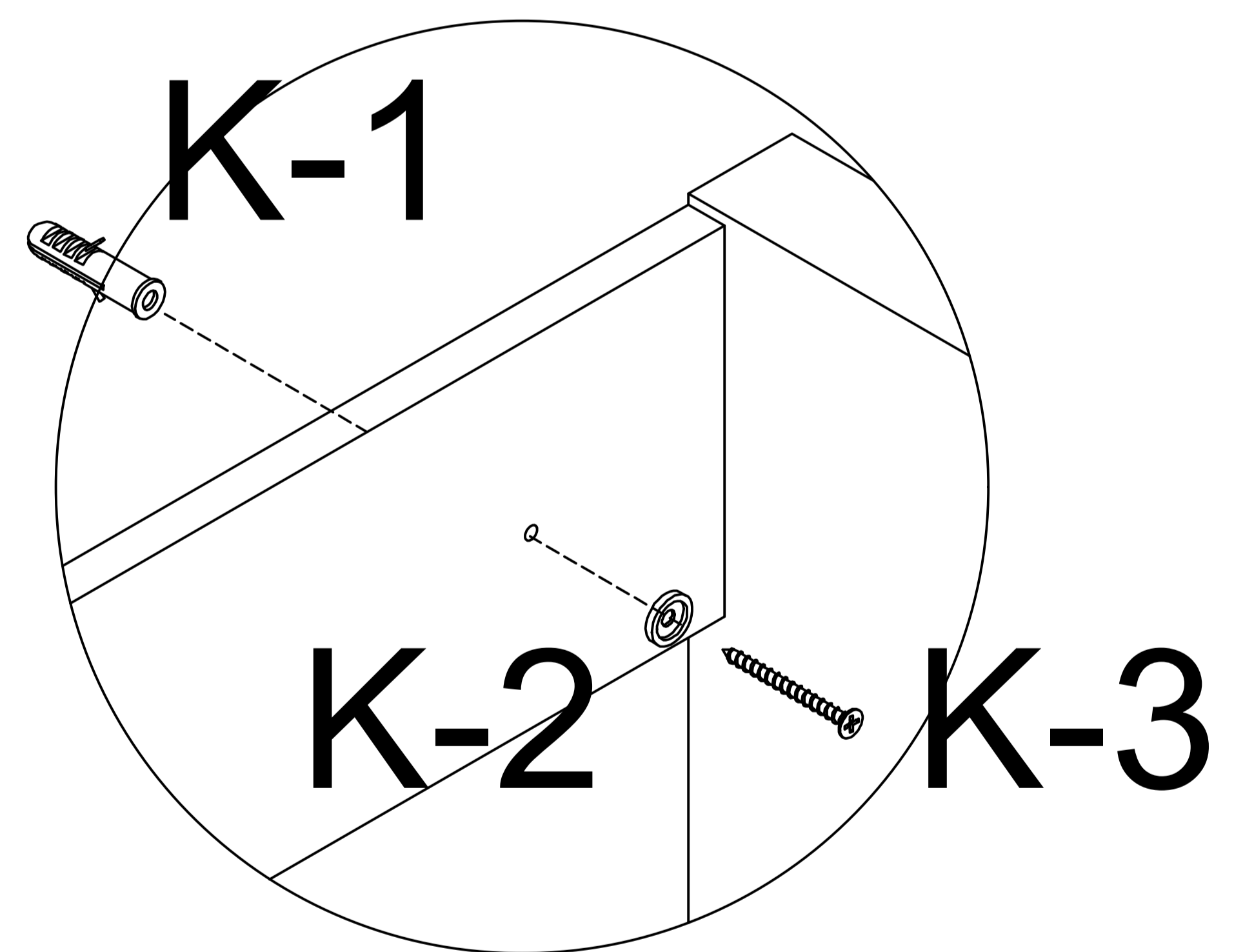
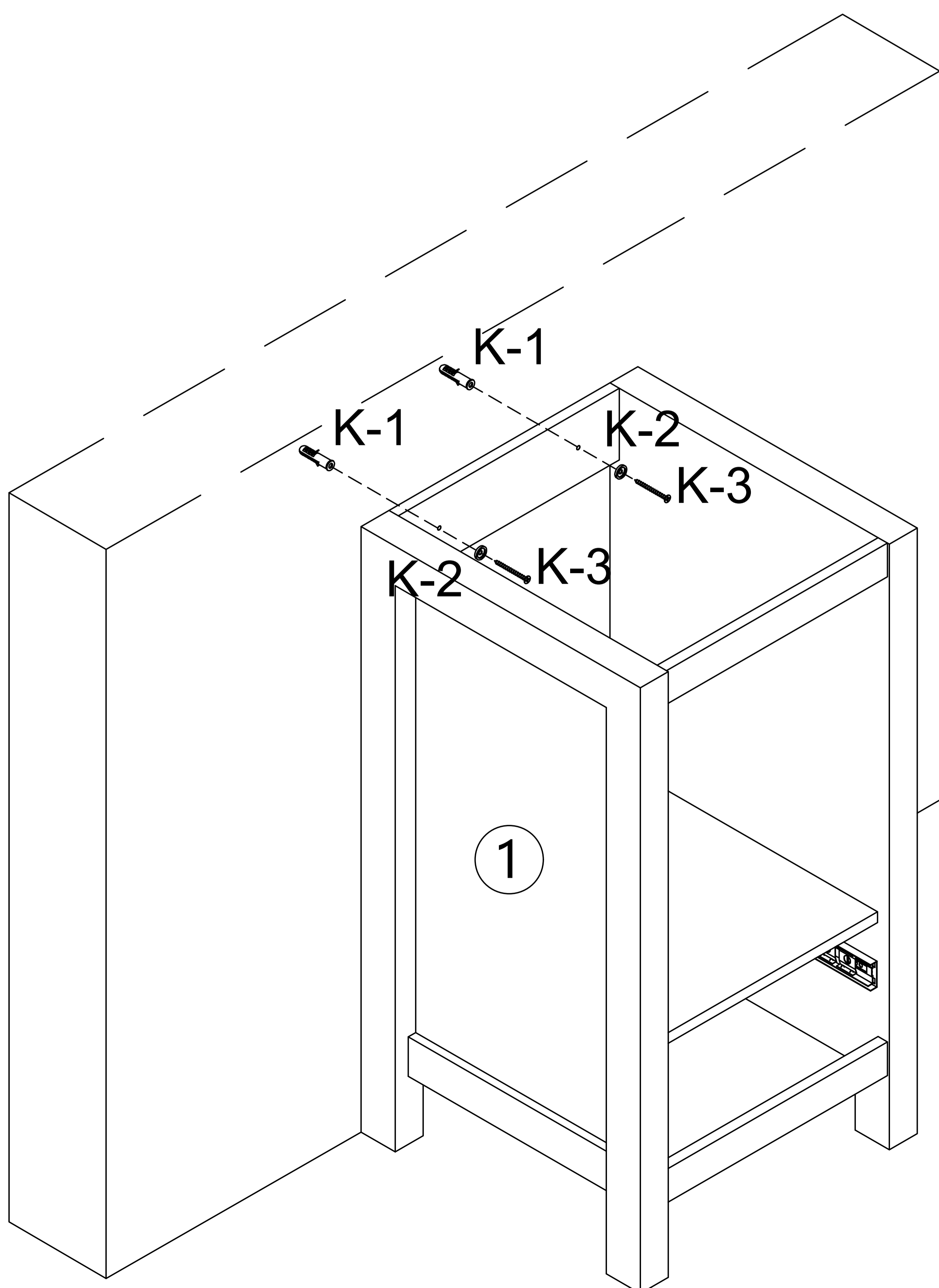

# 6

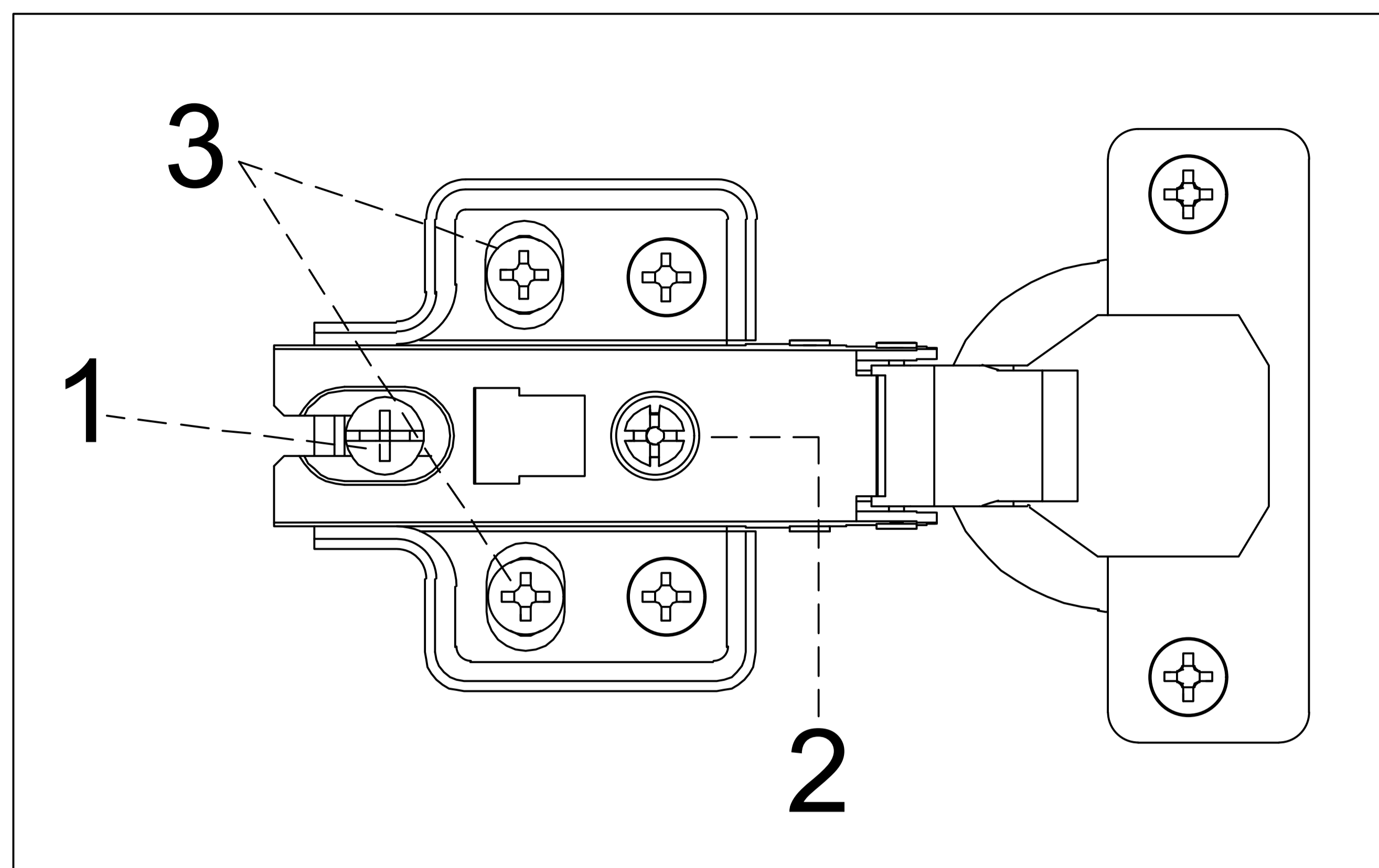

## Hinge Adjustment Guide

Three-way adjustable hinge for perfectly aligned doors

### Sideways/Gap Adjustment

Turning the screw "2" on the hinges of each door allows you to adjust the door to the left or right by a few millimeters.

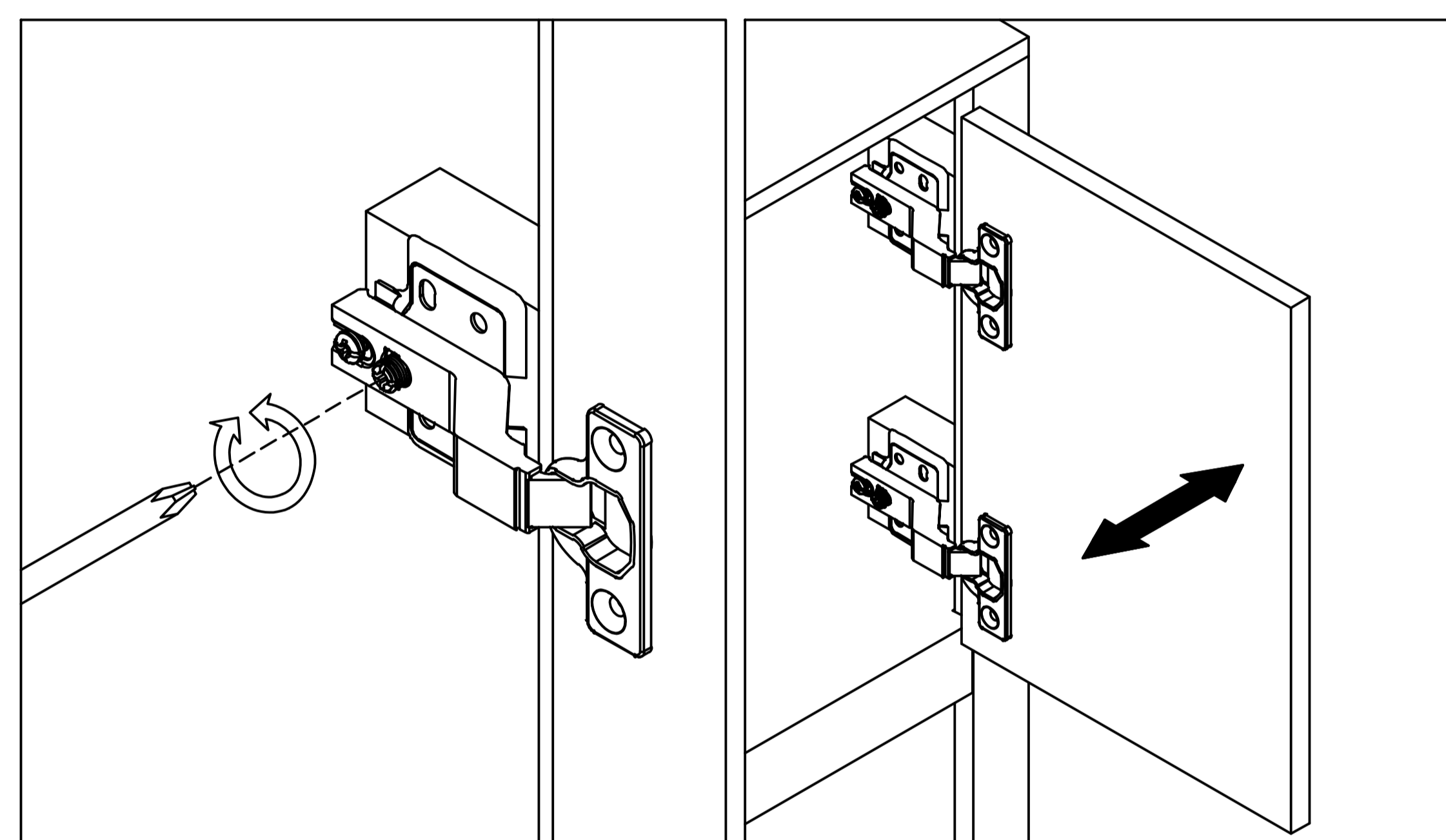

### Forward/Backward Alignment

Loosen screw "1" to adjust the door forward or backward. After adjustment, Tighten screw "1".

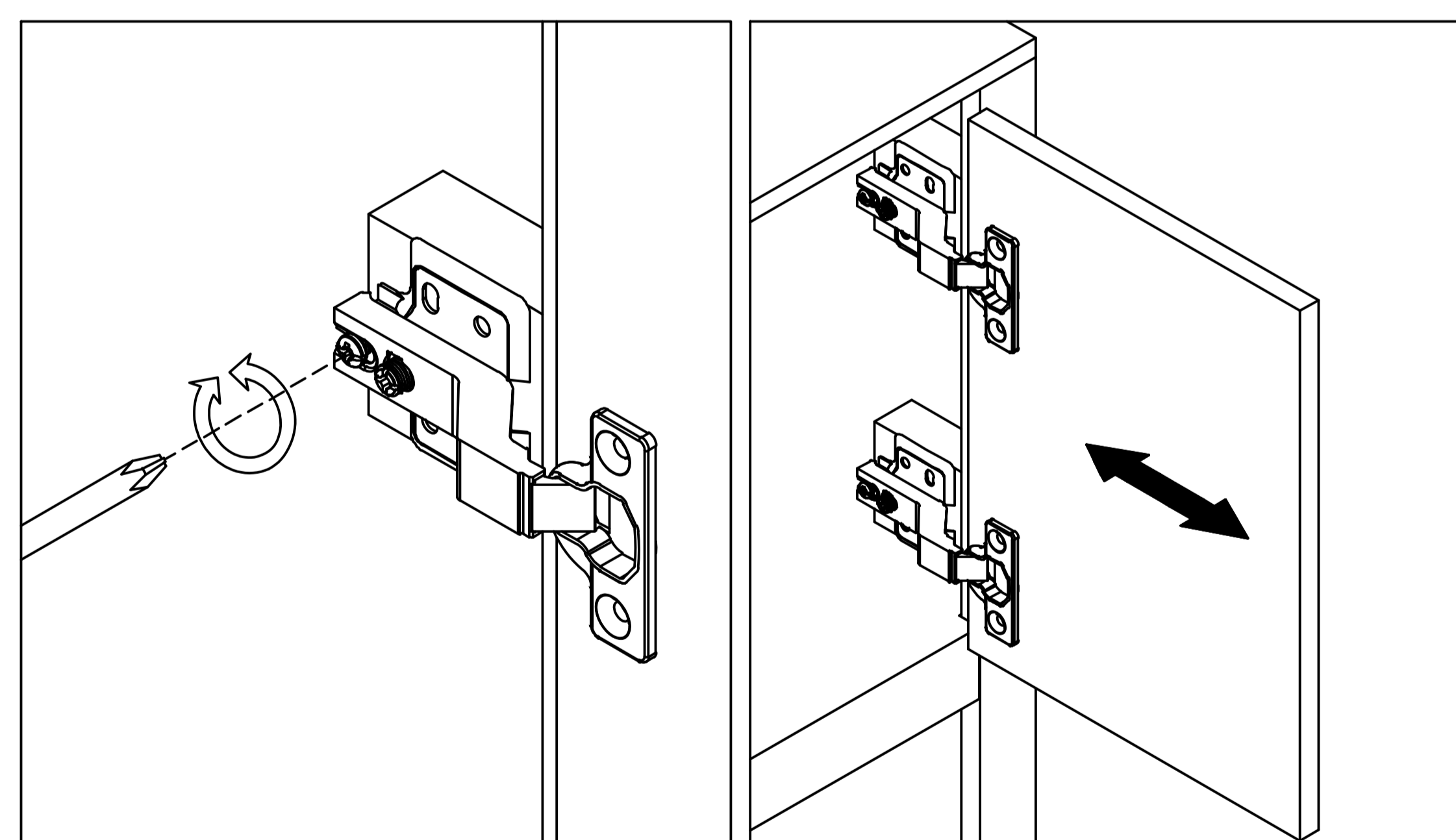

### Vertical Height Adjustment

Loosen screw "3" to adjust the door up or down. After adjustment, hold the door panel and tighten screw "3".

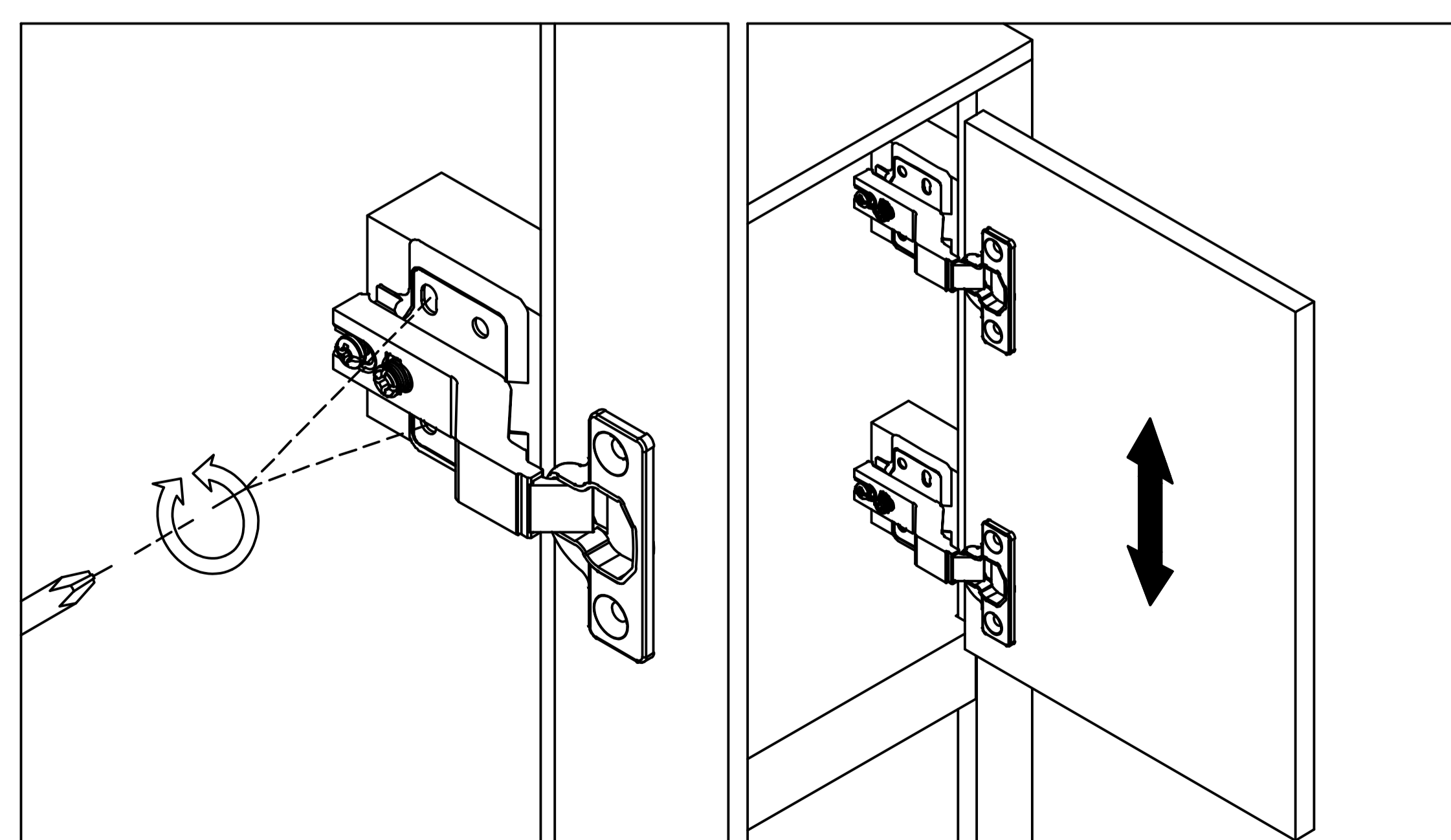

# 7

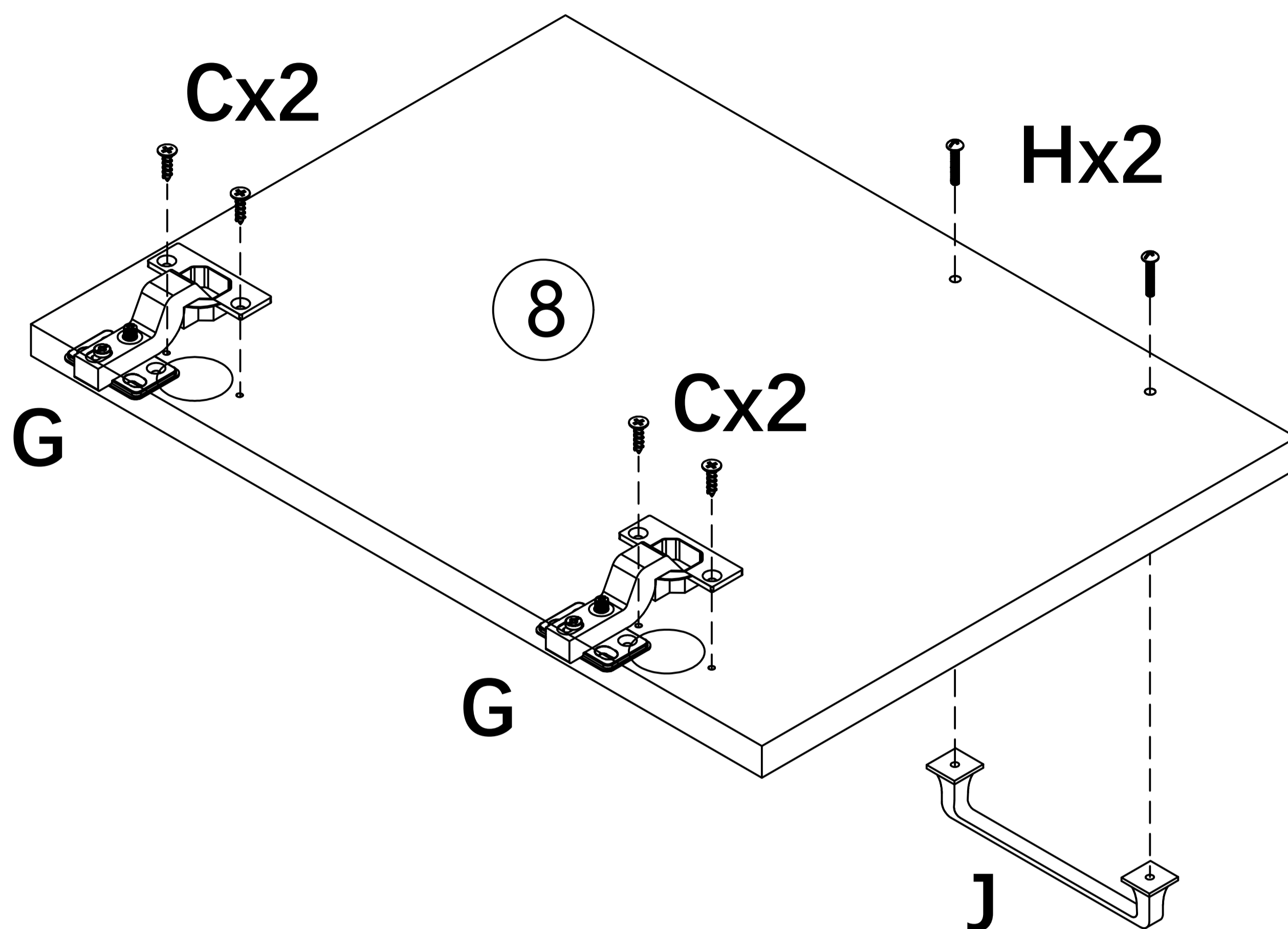
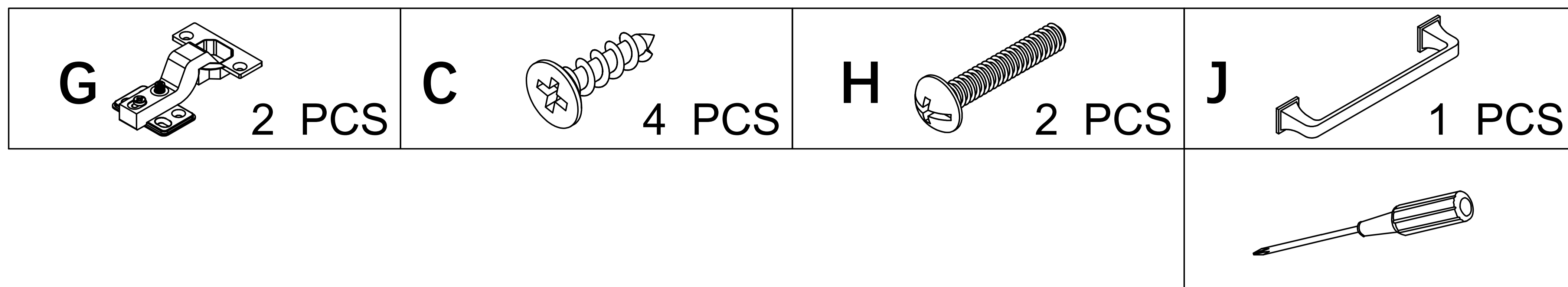

- Secure hinge (G) with screw (C), and fasten part (J) with screw (H).

# 8

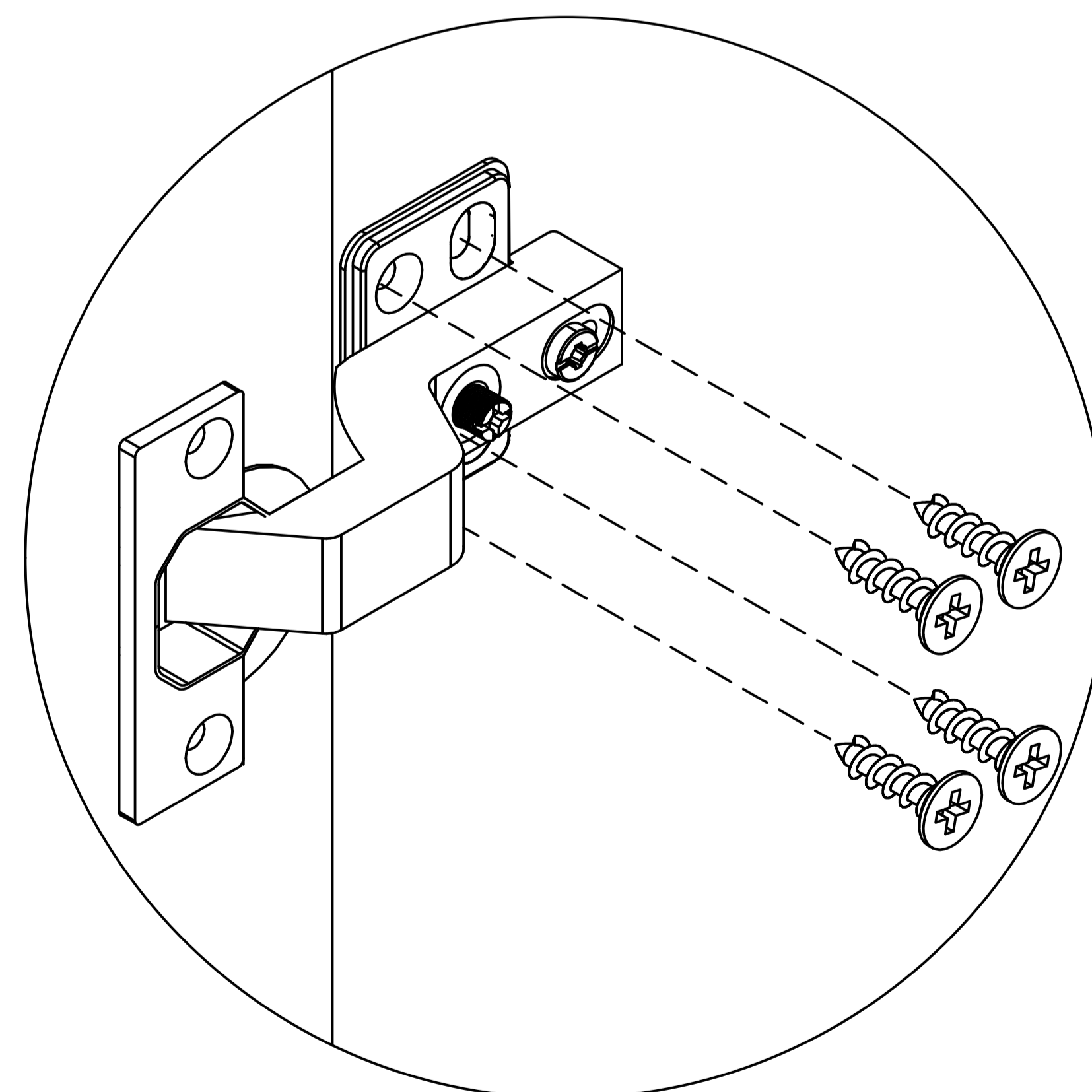
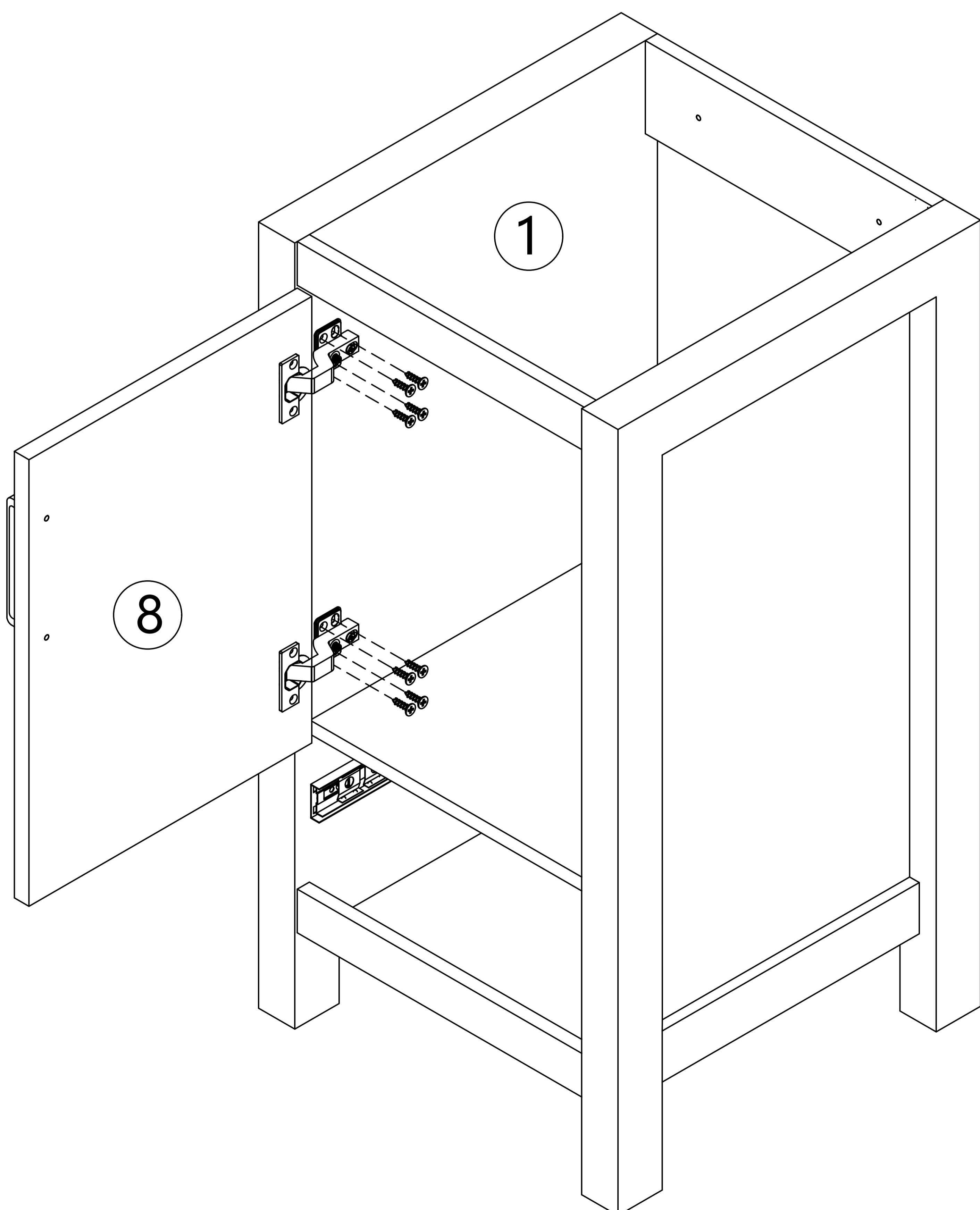
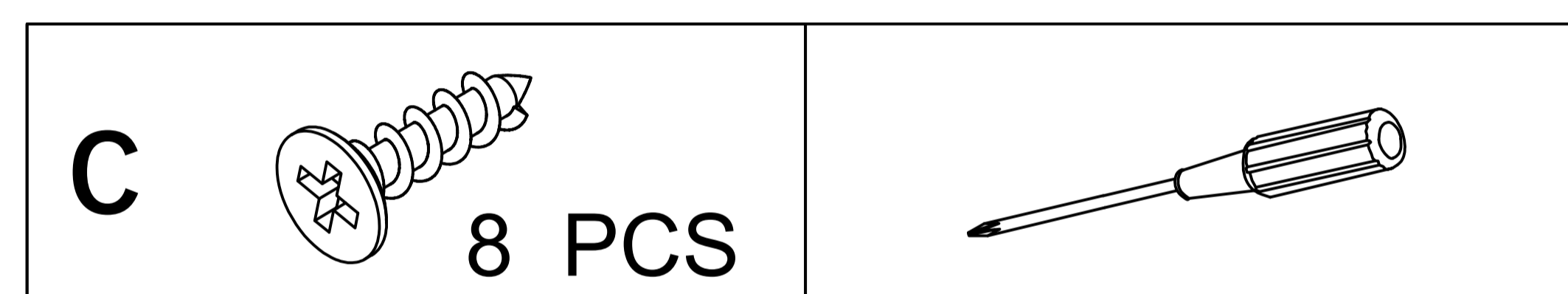

- Secure door panel (8) with screw (C).

# 9

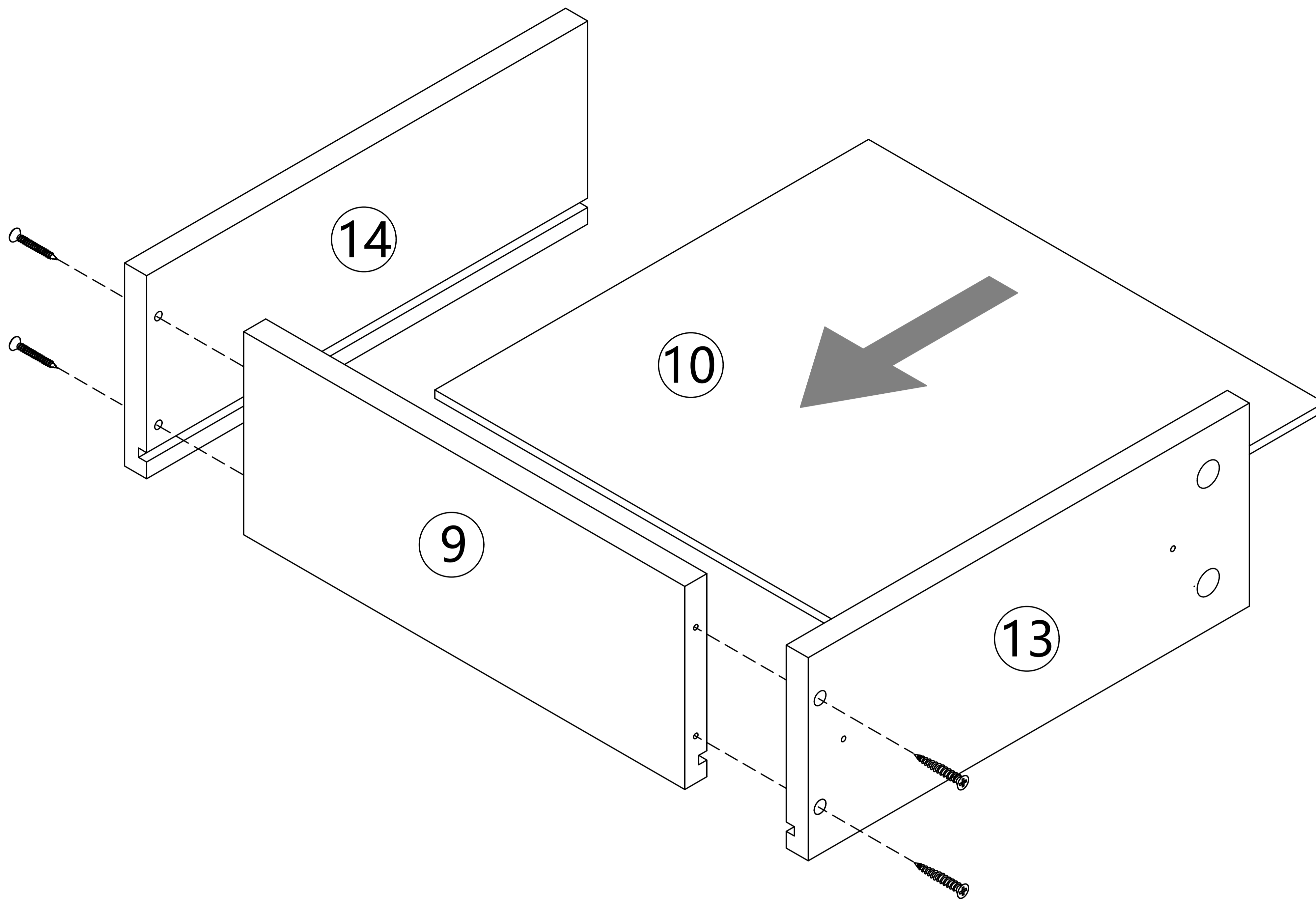
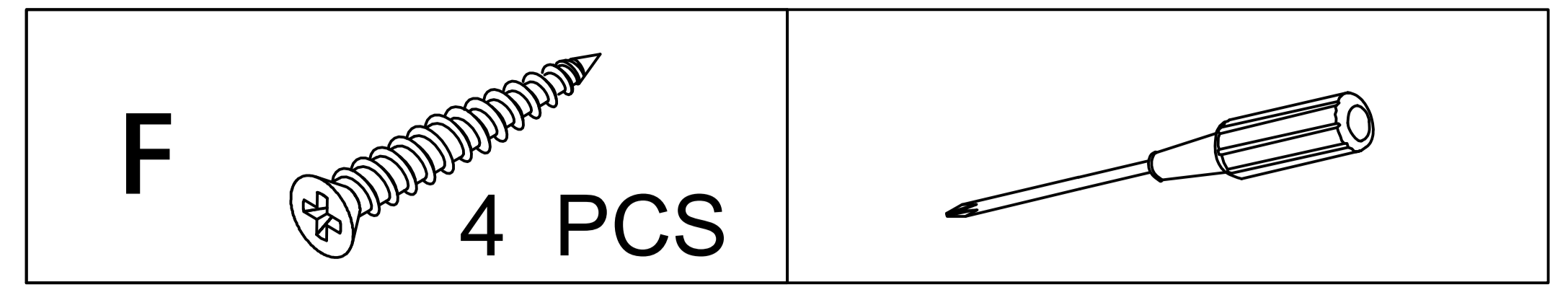

- Join the panels and secure them with screws (F).

# 10

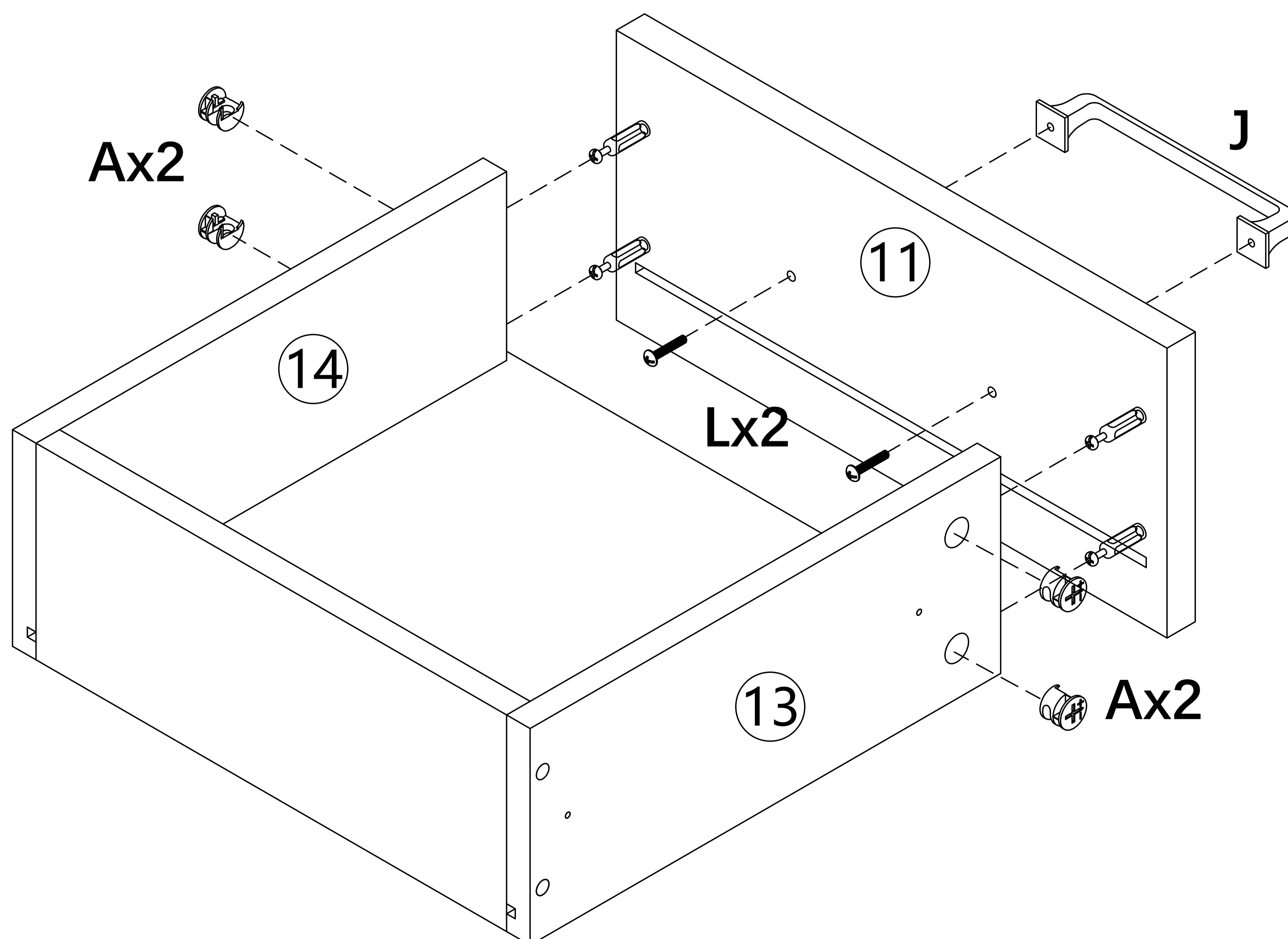
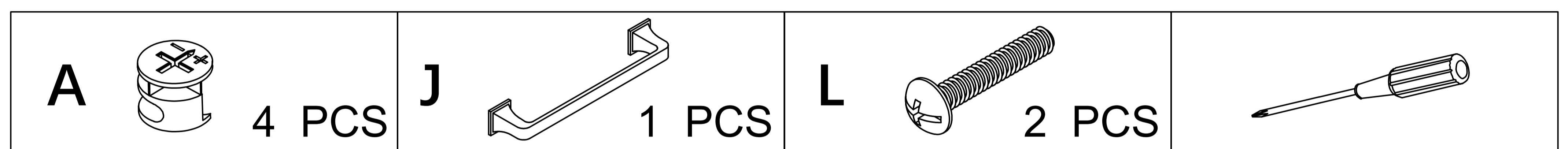

- Join the panels, fasten them with cam lock (A), and secure part (J) with screw (L).

# 11

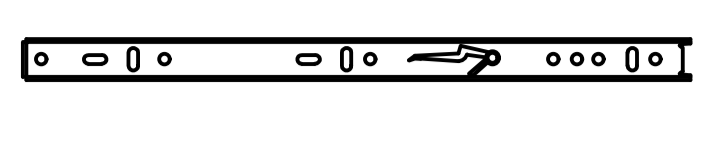
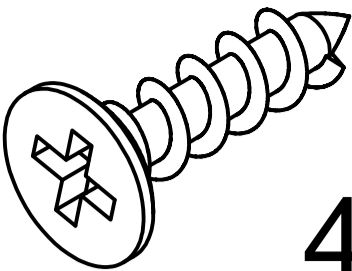
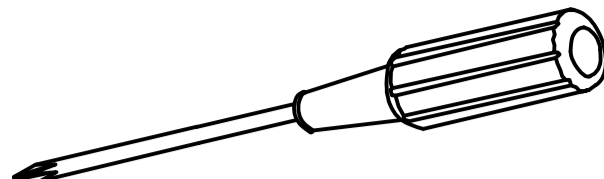
<b>D 1</b>  2 PCS	<b>C</b>  4 PCS	
--	--	---

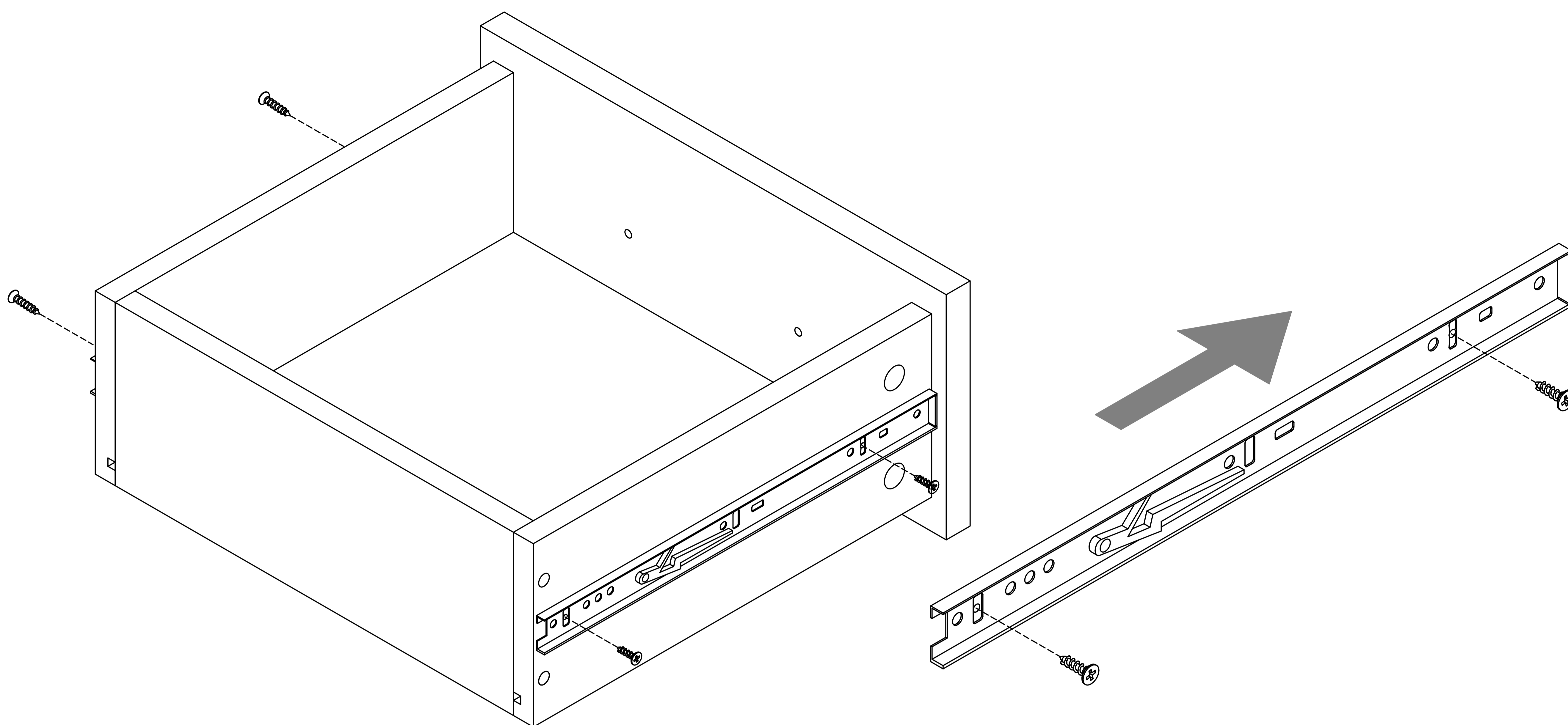

- Secure slide rail (D1) with screw (C).

# 12

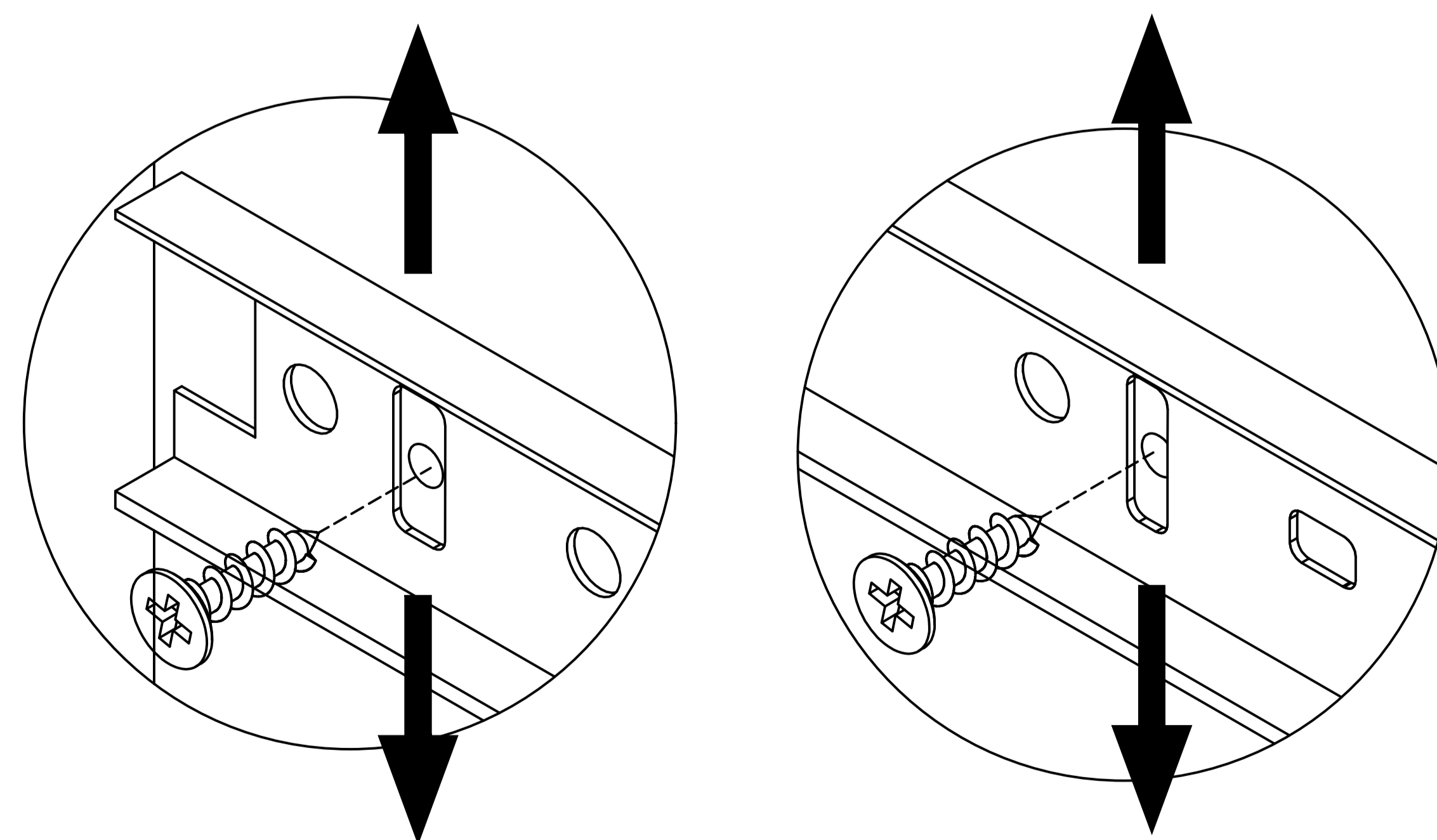
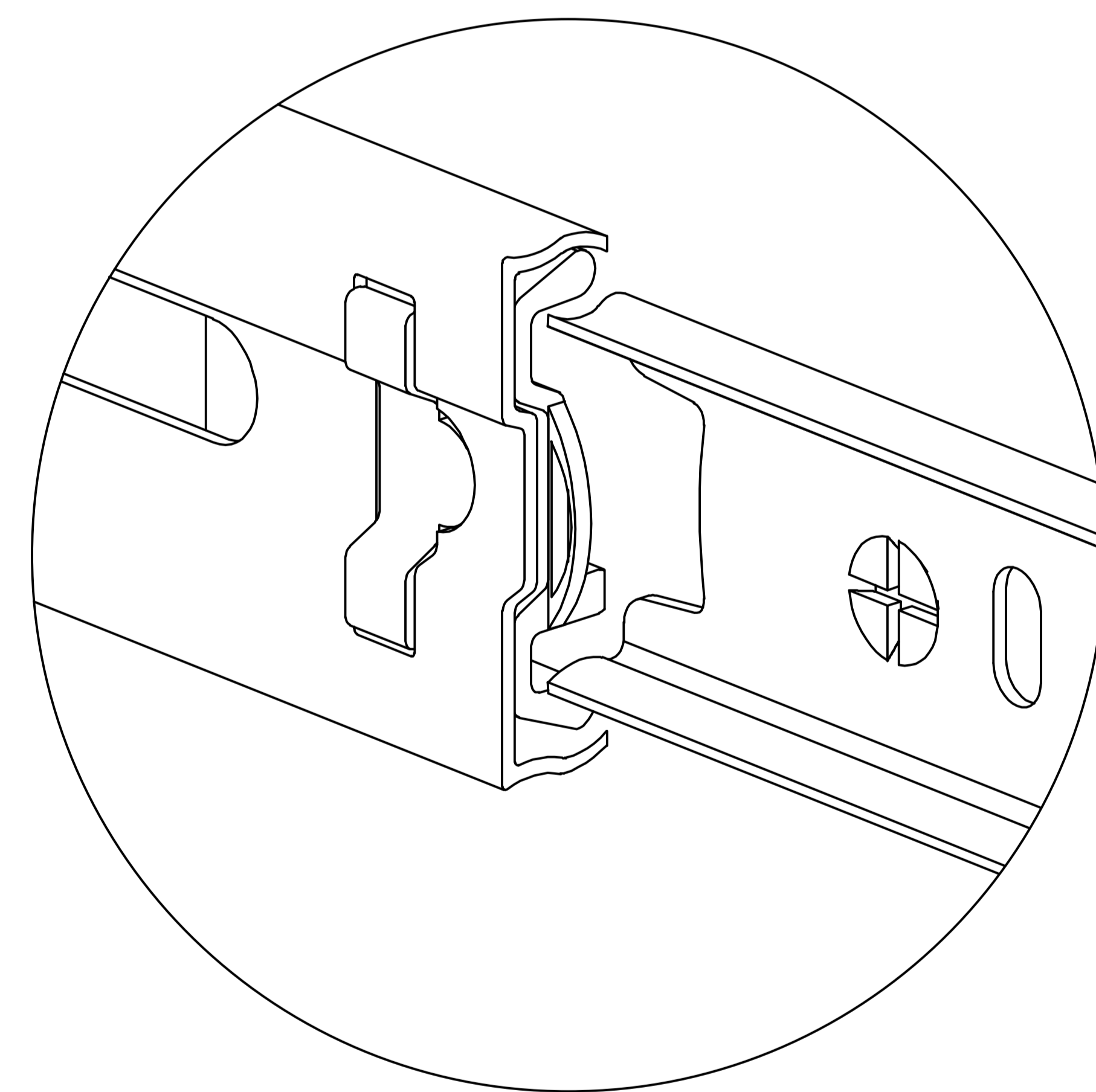
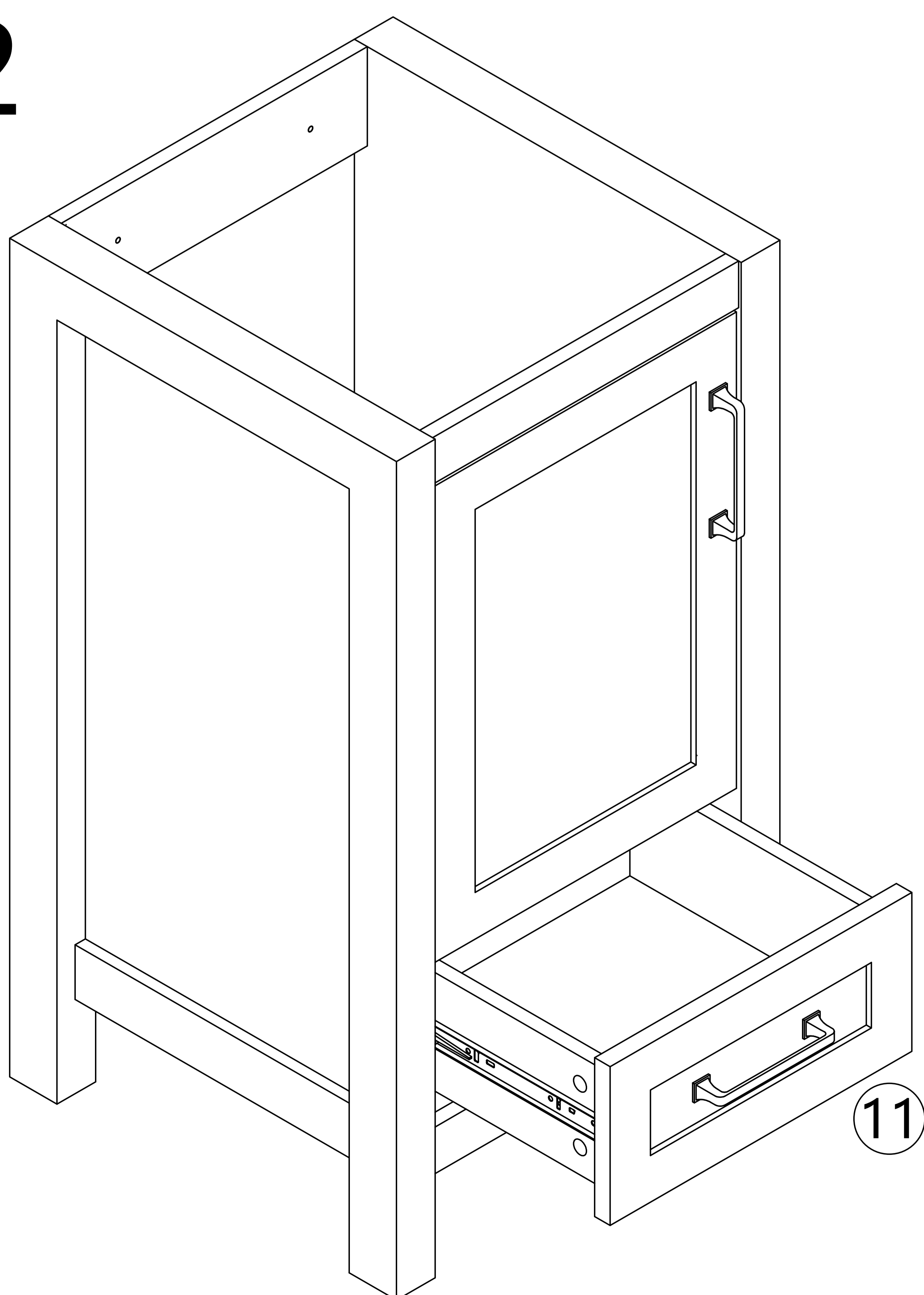

- Install the drawer.

- If the drawers are not in the same level, please adjust the screws in the drawer box.

13

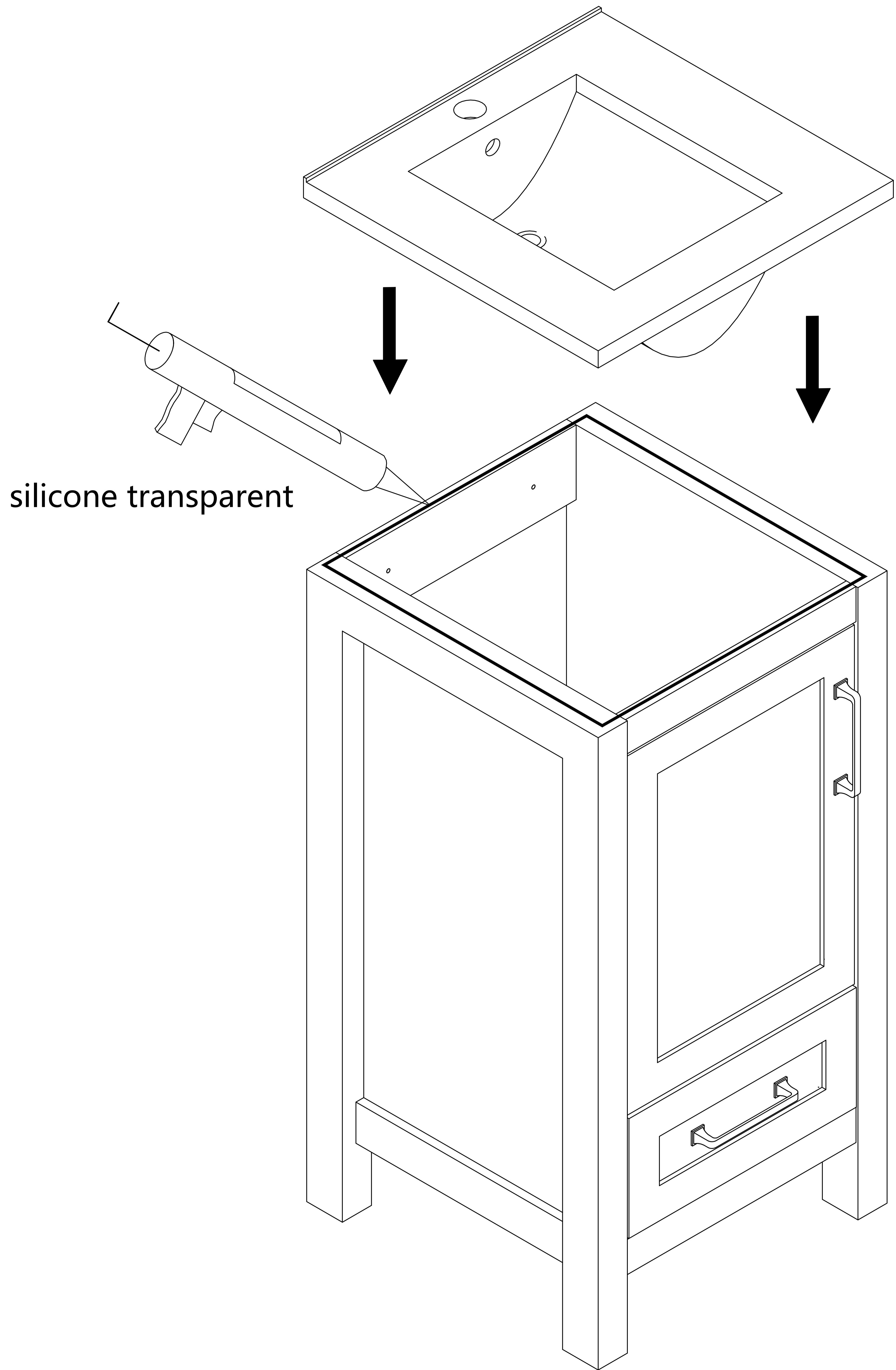

# THANK YOU

Thank you for choosing our product. We sincerely hope that the assembly process has been smooth and enjoyable for you. If you have any questions or suggestions during the use of the product, please feel free to contact us.

