

# Assembly Instructions

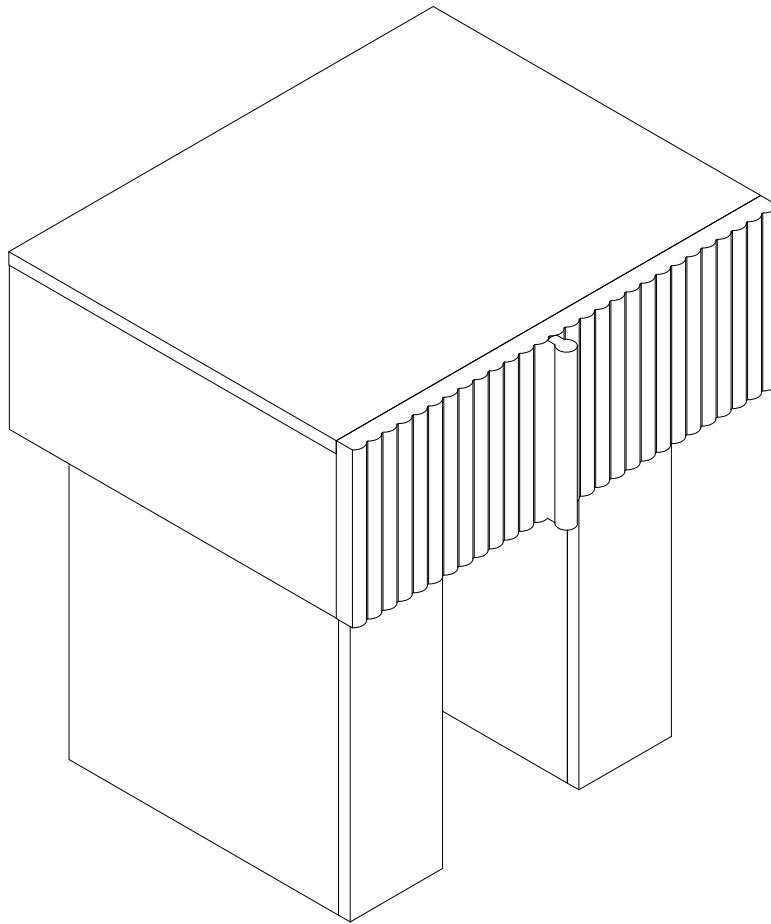

# Contact Us

## We're here to help you.

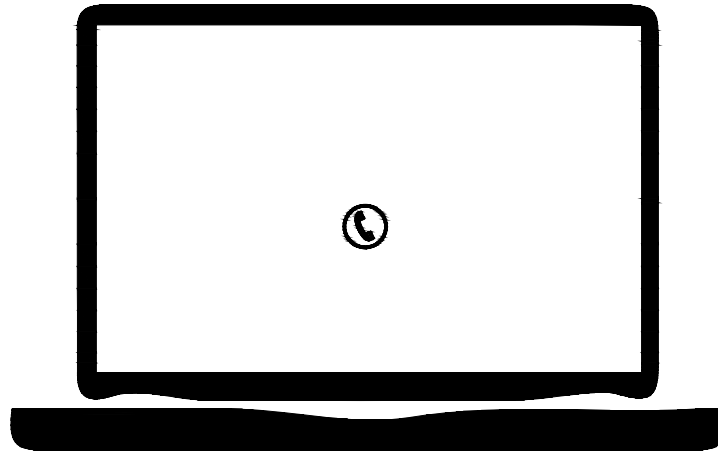

Your satisfaction is our top priority. If you encounter any issues with this product, such as missing or damaged parts, we're here to help. Please retain the original packaging and take photos of the packaging and the product, then contact us as soon as possible.

### Warm Tips

1. Carefully read these instructions and keep them for future reference.
2. Check the parts list and confirm everything's there before starting assembly.
3. When assembling, put all parts on a soft, smooth surface like a carpet to avoid scratches.
4. Don't fully tighten screws until all parts are confirmed in place to avoid misalignment.

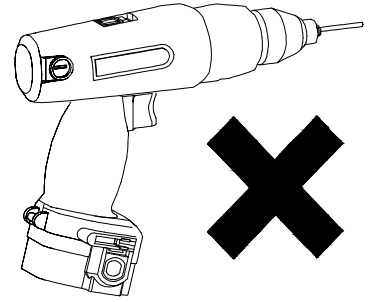
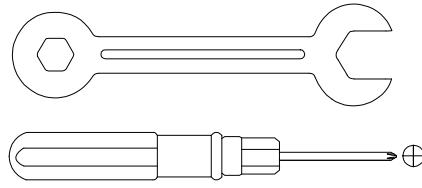
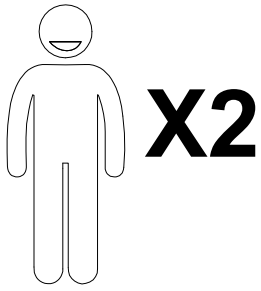

We recommend using hand tools for assembly.

If an electric screwdriver is used, reduce power and torque to avoid damage to the product.

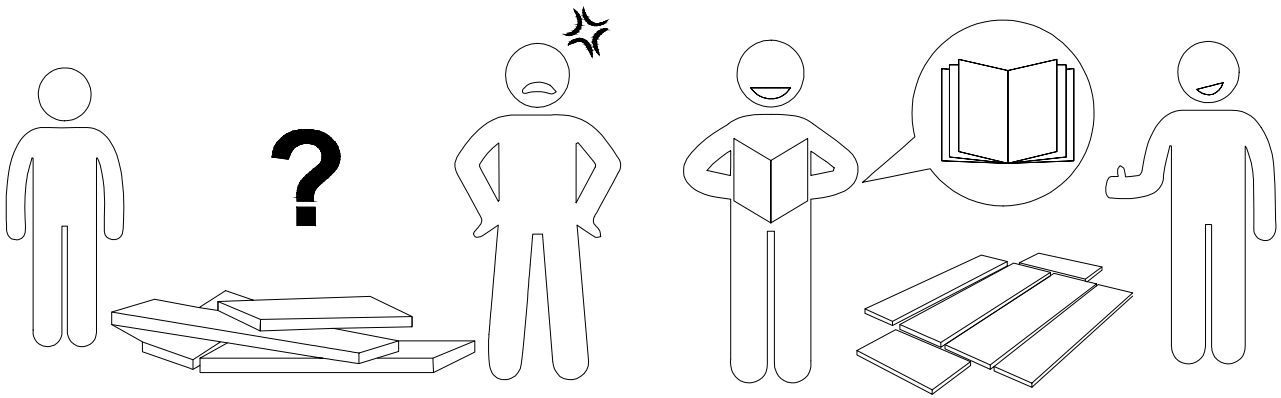

## AVOID SCRATCHES

In order to avoid scratching, this furniture should be assembled on a soft surface, such as a rug.

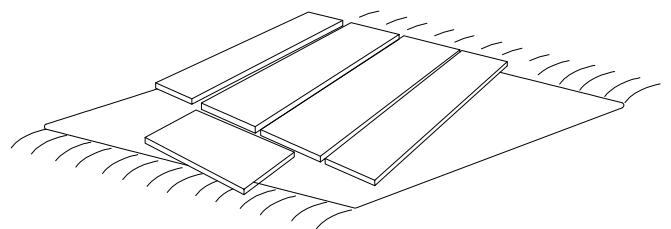
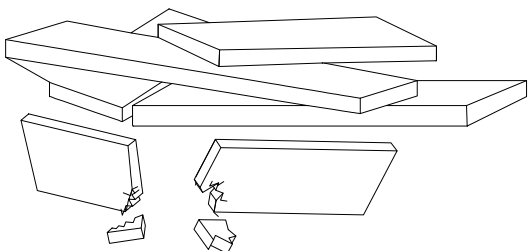

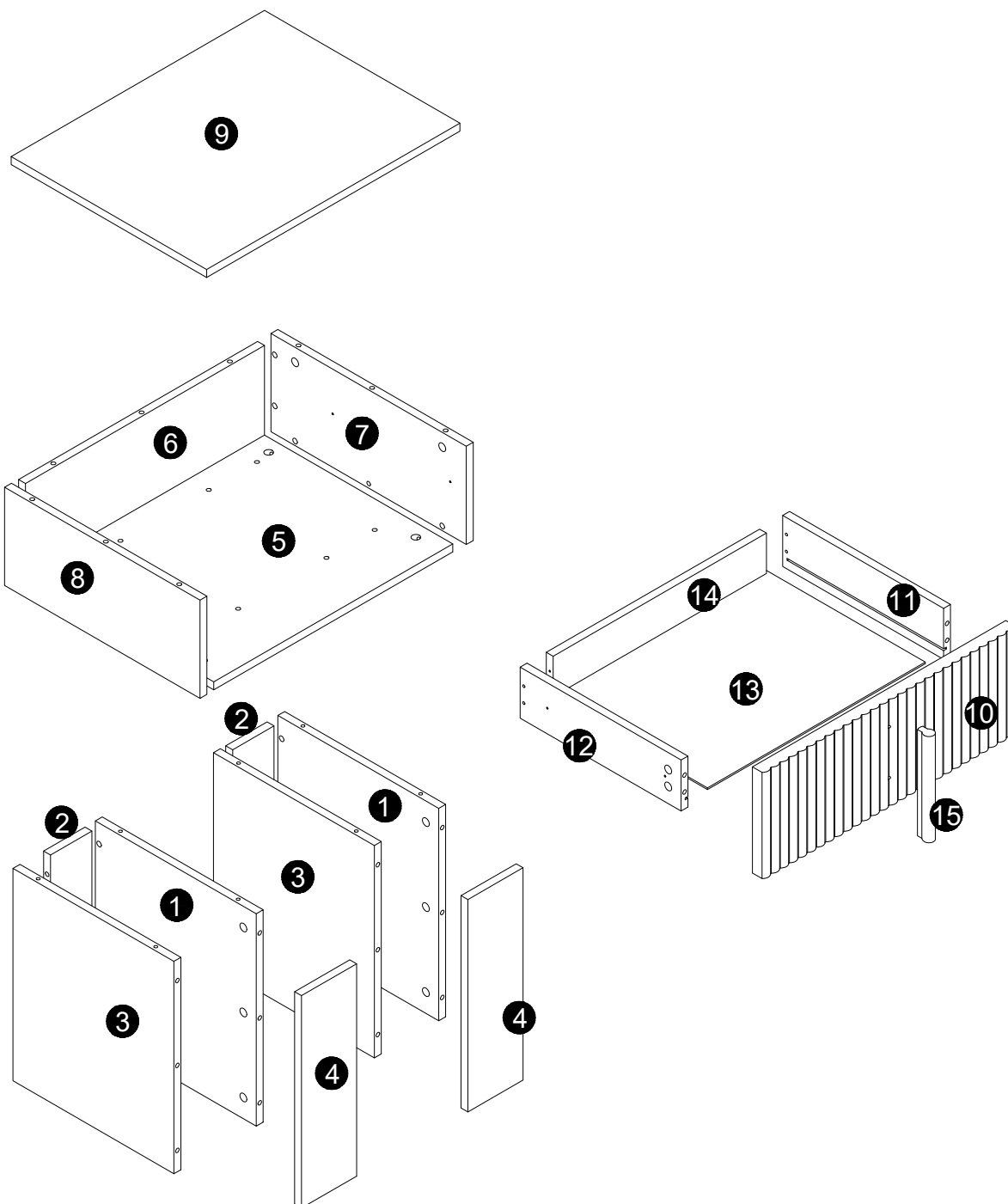





**⚠ Caution**

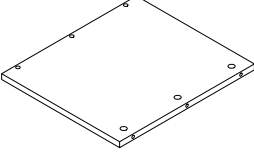
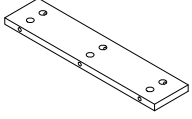
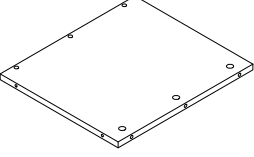
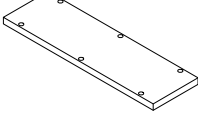
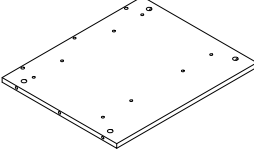
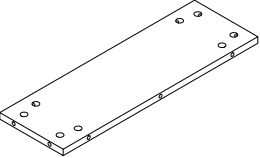
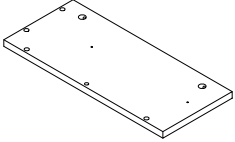
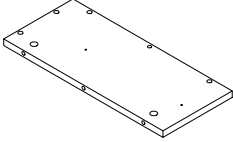
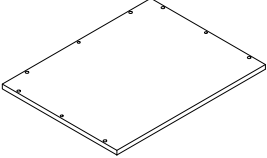
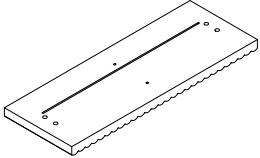
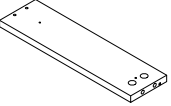
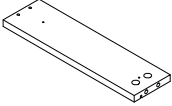
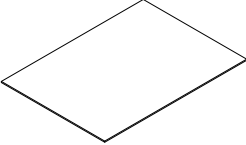
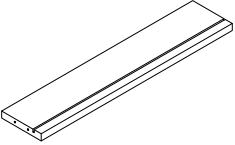
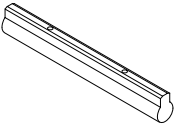

Make sure all parts are included. Most board parts are labeled or stamped on the raw edge. Contact us for a free replacement if you encounter any damaged or missing parts.

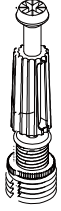
# Parts List

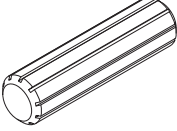
<p><b>1</b></p>  <p>2 pcs</p>	<p><b>2</b></p>  <p>2 pcs</p>	<p><b>3</b></p>  <p>2 pcs</p>	<p><b>4</b></p>  <p>2 pcs</p>	<p><b>5</b></p>  <p>1 pc</p>
<p><b>6</b></p>  <p>1 pc</p>	<p><b>7</b></p>  <p>1 pc</p>	<p><b>8</b></p>  <p>1 pc</p>	<p><b>9</b></p>  <p>1 pc</p>	<p><b>10</b></p>  <p>1 pc</p>
<p><b>11</b></p>  <p>1 pc</p>	<p><b>12</b></p>  <p>1 pc</p>	<p><b>13</b></p>  <p>1 pc</p>	<p><b>14</b></p>  <p>1 pc</p>	<p><b>15</b></p>  <p>1 pc</p>

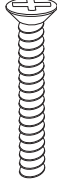
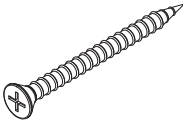
# Hardware List

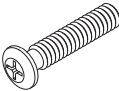
A	B	C	D	E	F
 M6x35mm	 Ø15x12mm	 Ø8x30mm	 Ø3.5x14mm	 Ø7x38mm	 Ø3.5x35mm
44 pcs	44 pcs	6 pcs	8 pcs	8 pcs	4 pcs

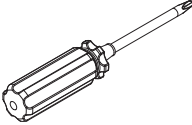
G	H	I	J		
 M4x30mm	 14"	 8 pcs	 Screwdriver		
2 pcs	1 Set	8 pcs	1 pc		

## Installation of Cams and Pins

Step 1-2: Align the plastic part with the mounting hole and press it in. If you can't press it in, loosen the screw counter clockwise or completely remove the screw from the plastic part and try again.  
Step 3-4: After pressing the plastic part into place, use a screwdriver to tighten the screw clockwise.

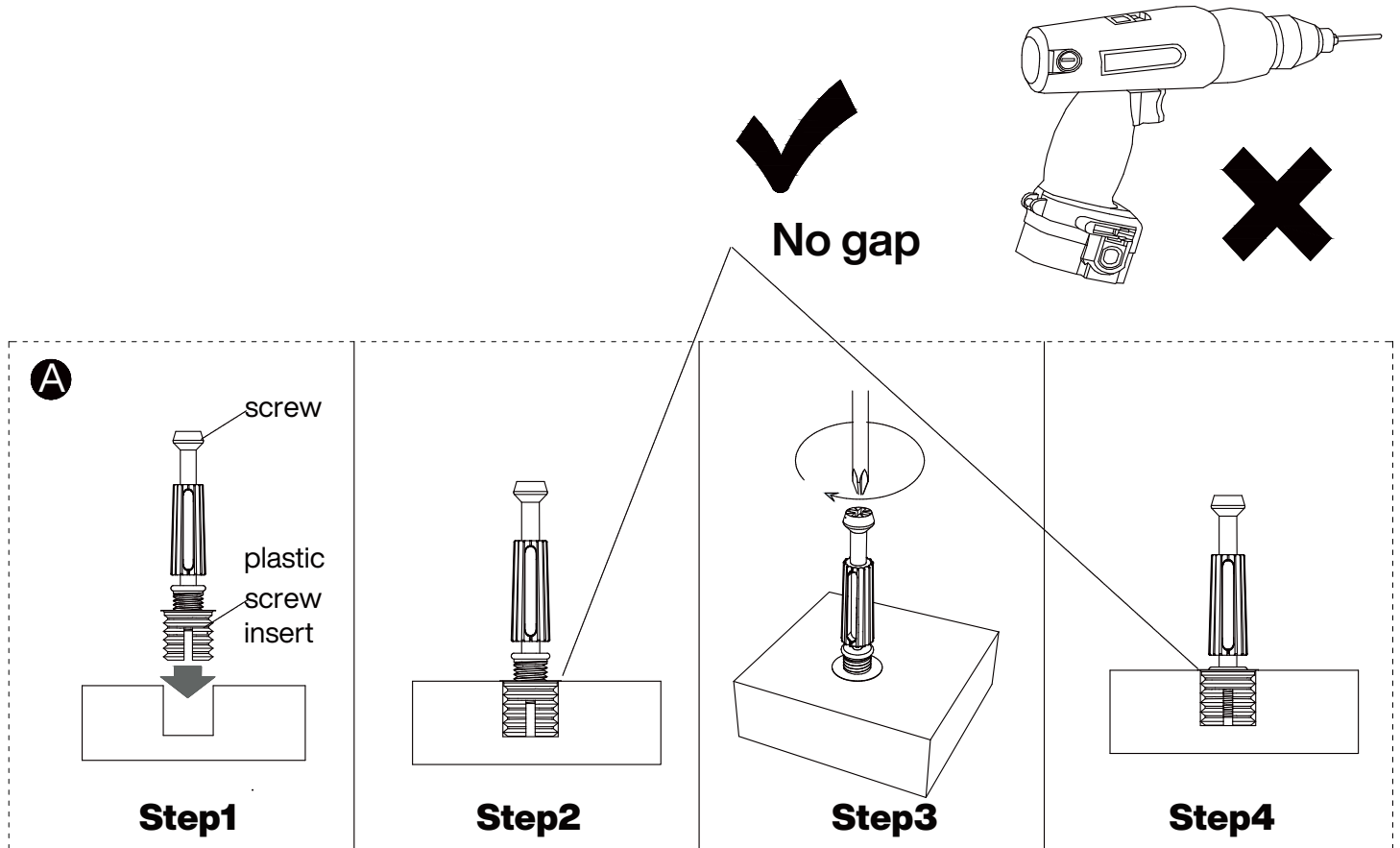

Screw the pin into the hole. Set the cams correctly by aligning the head of the cams with the lock pins. Lock the cam by turning the cam head with a screwdriver until it is tightened. Please do not use an electric screwdriver to assemble the unit.

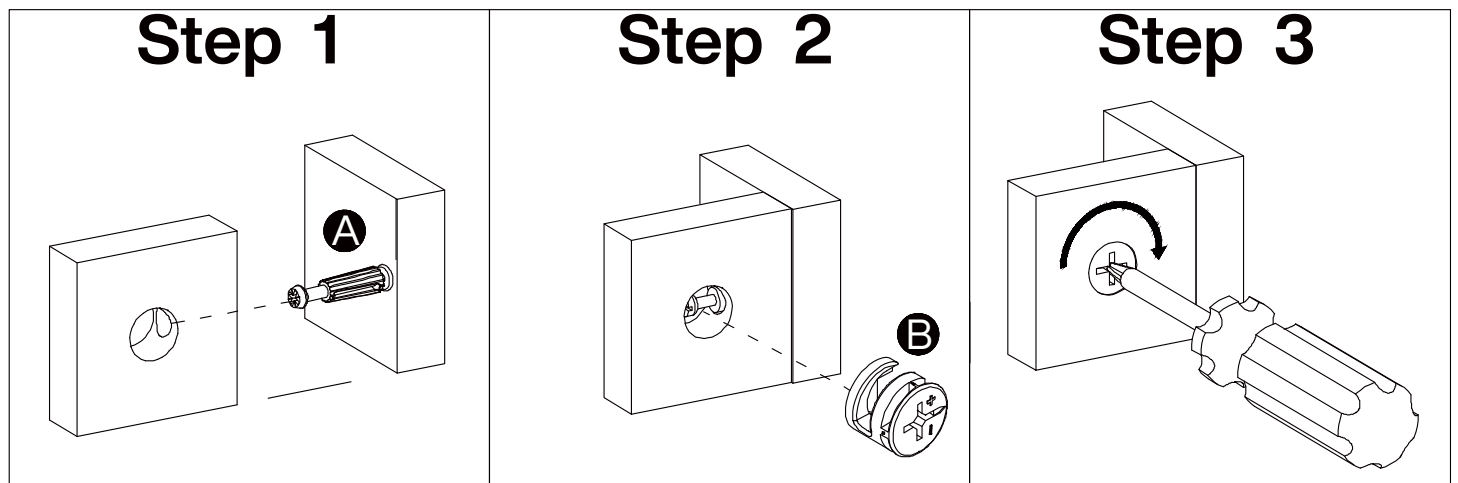

Please split component "H" into "H-1" and "H-2" before assembling the slide and then proceed to the next step of assembly

### Step 1

Pull apart component "H" to each side, and then gently push up the lever of component "H-2"

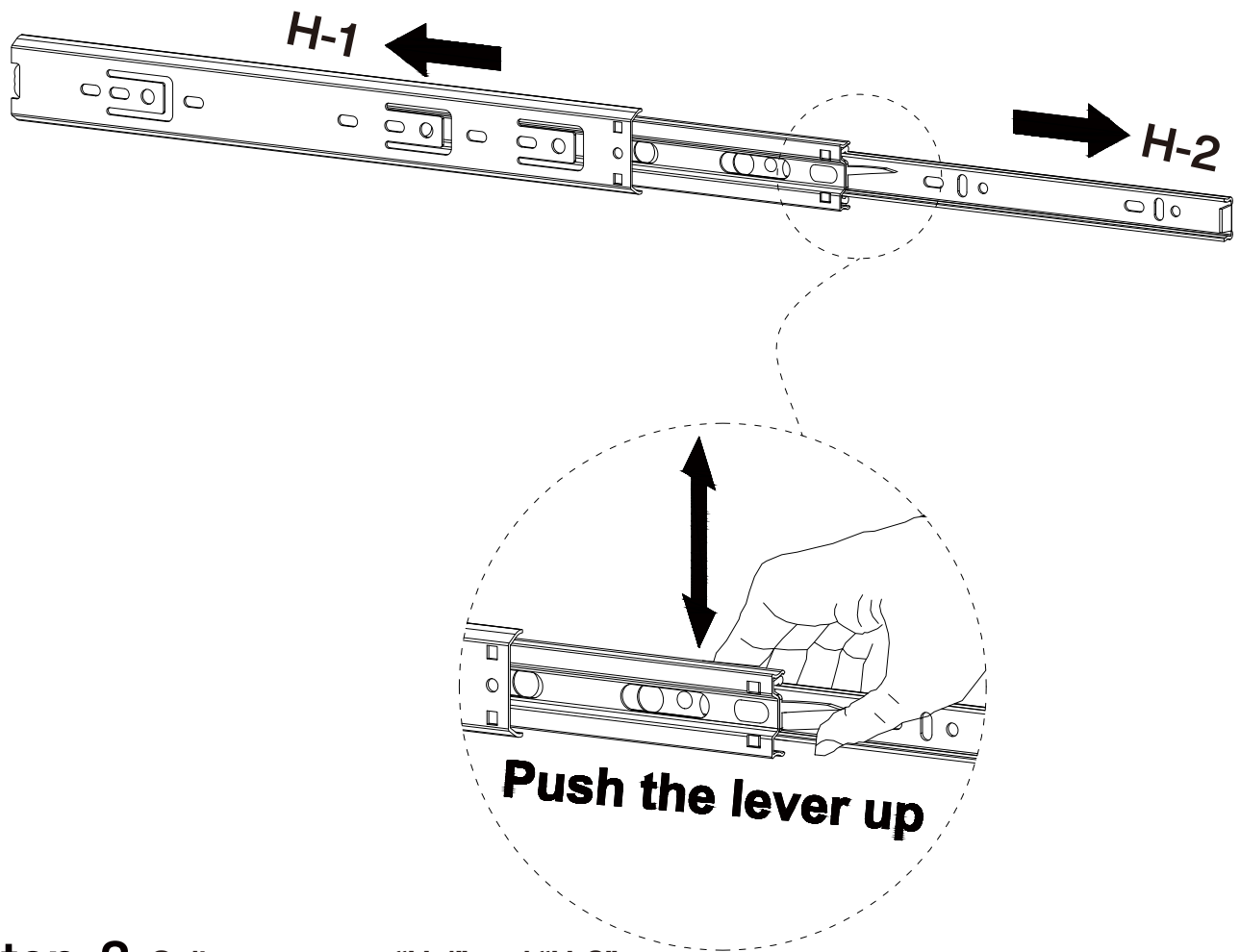

### Step 2 Split component "H-1" and "H-2"

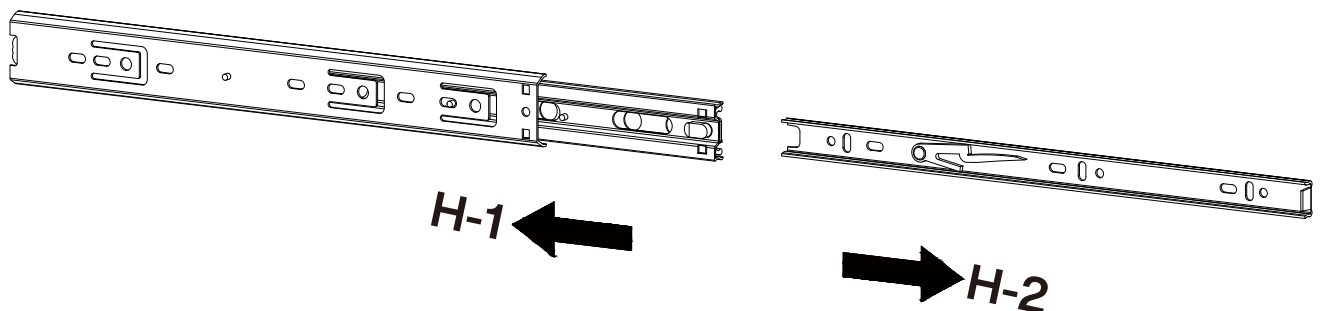

**1**

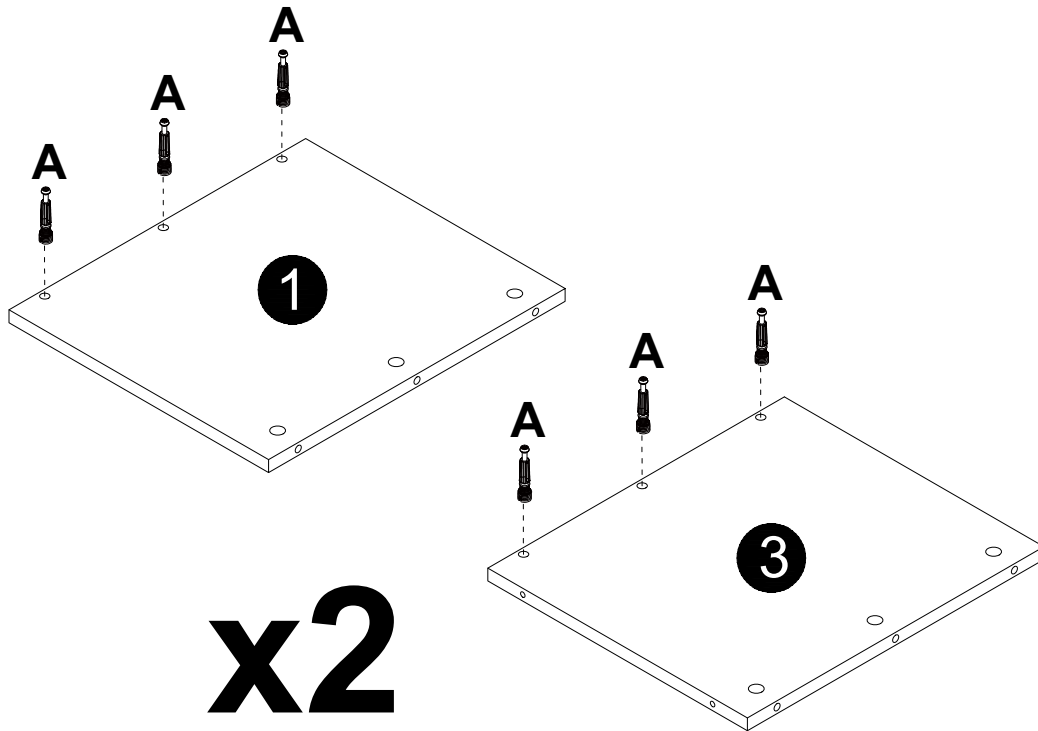

<b>A</b>

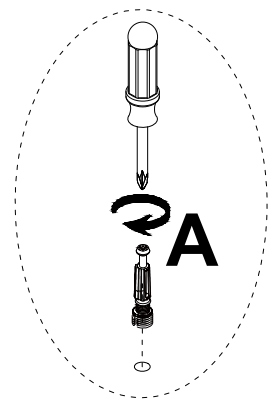
M6x35mm
12 pcs

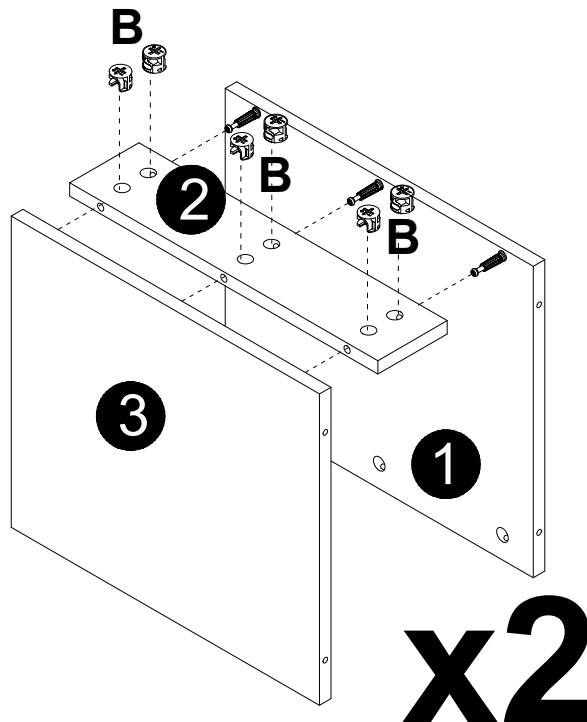
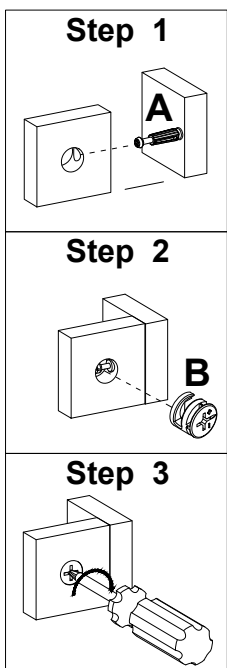

**2**



<b>B</b>

Ø15x12mm
12 pcs

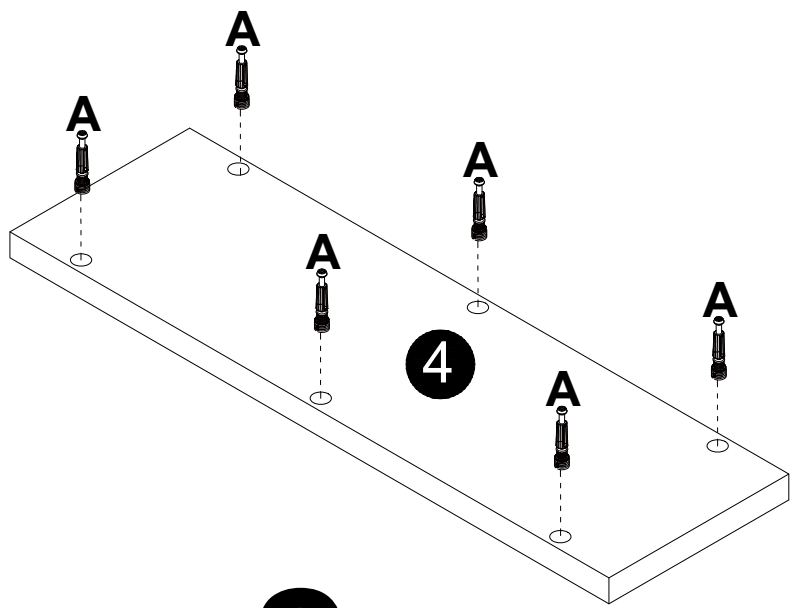
**3**

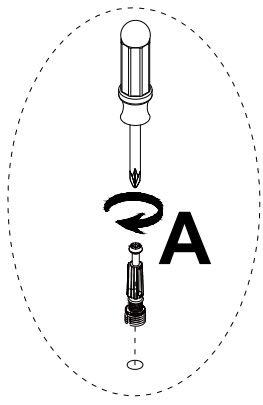

**x2**

<b>A</b>

M6x35mm
12 pcs

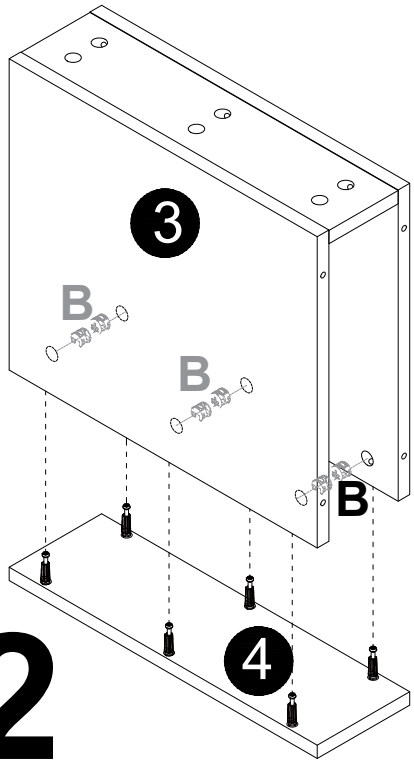
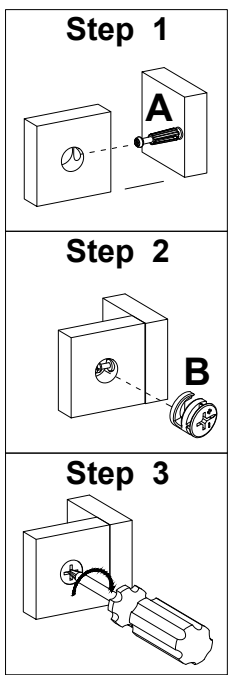

**4**



**x2**

<b>B</b>

Ø15x12mm
12 pcs

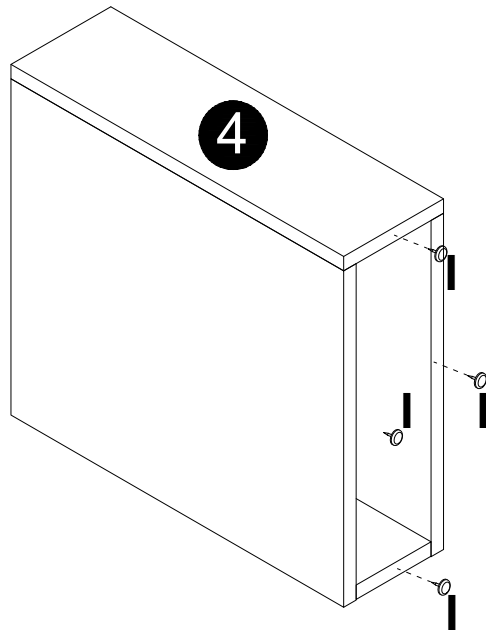
5

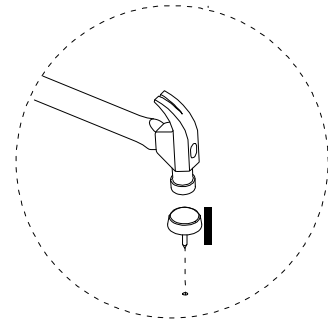

I

8 pcs



x2

**⚠ Caution! Tap lightly**

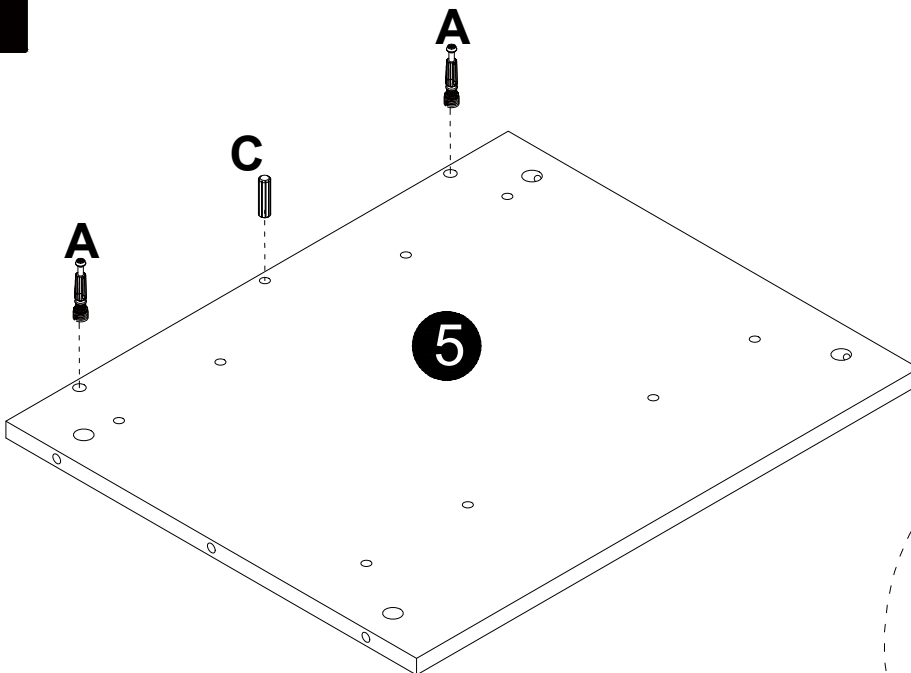
6

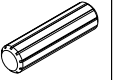

A	C
	
M6x35mm 2 pcs	Ø8x30mm 1 pcs

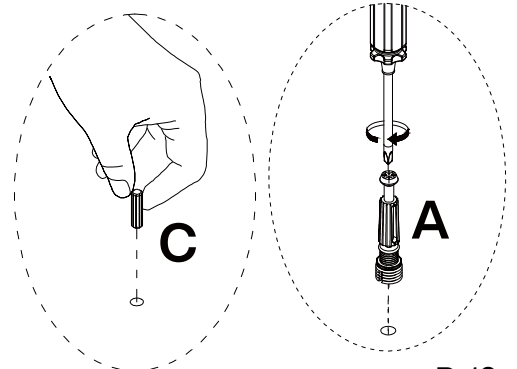

7

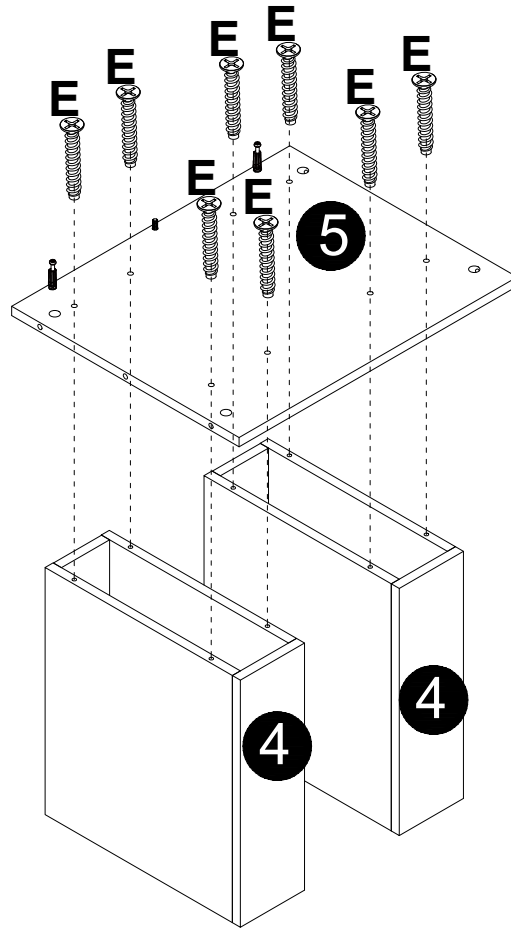

<b>E</b>

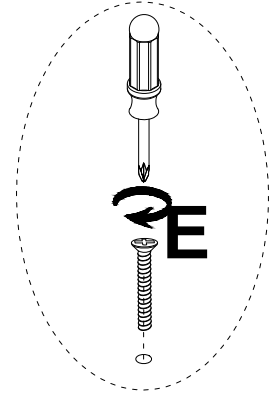
Ø7x38mm 8 pcs



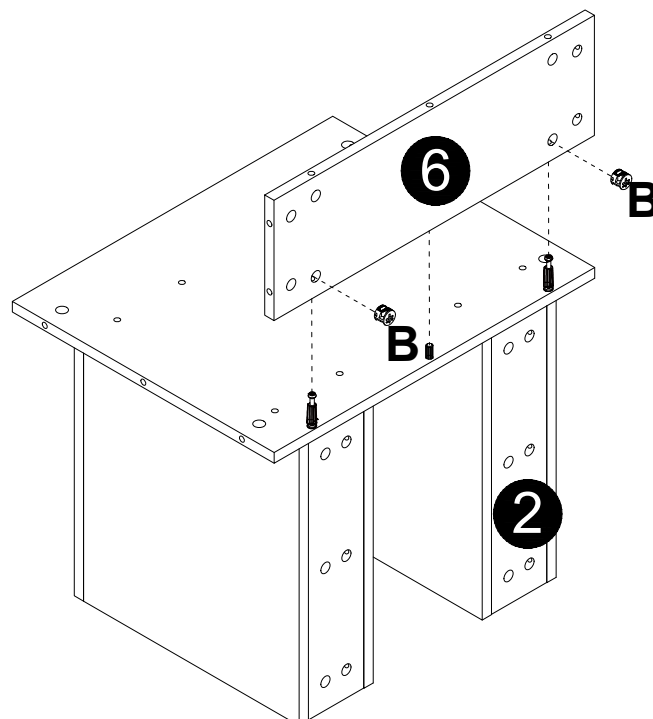
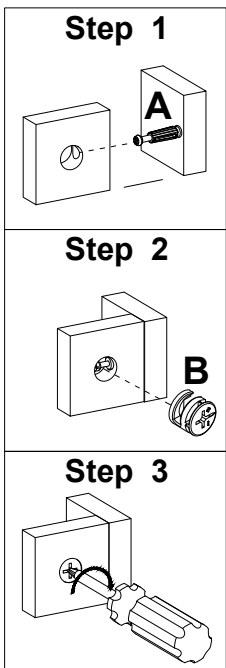



8

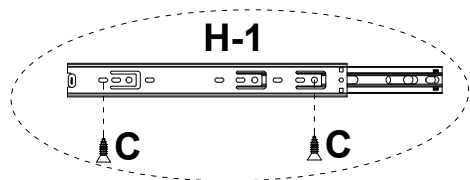

<b>B</b>

Ø15x12mm 2 pcs

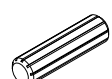
9



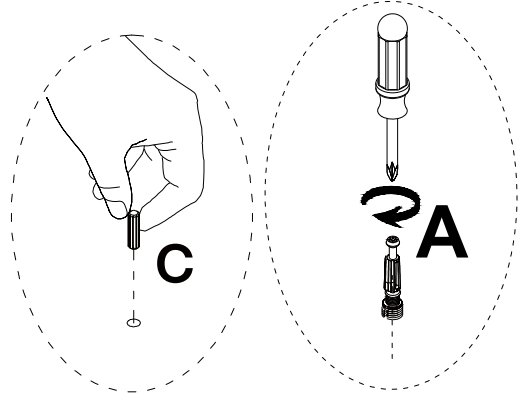
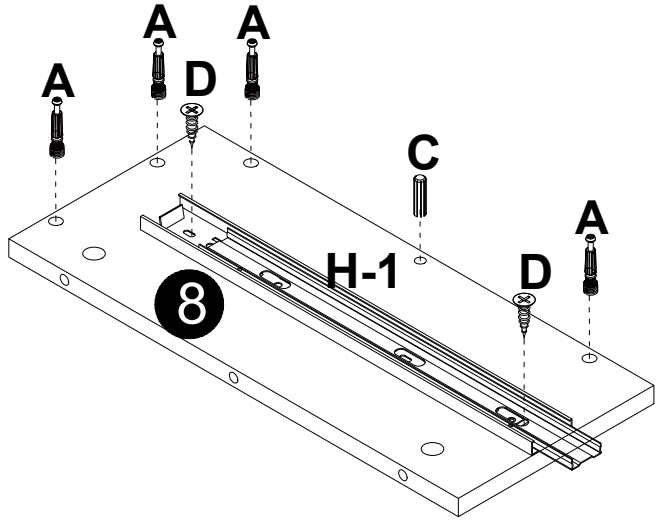

<b>A</b>	<b>C</b>
	
M6x35mm 4 pcs	Ø8x30mm 1 pcs
<b>D</b>	<b>H-1</b>
	
Ø3.5x14mm 2 pcs	1 pcs

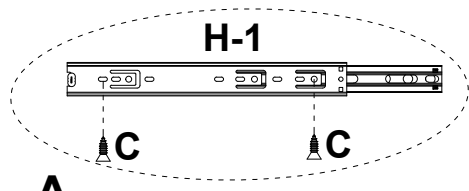

10

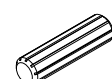

<b>A</b>	<b>C</b>
	
M6x35mm 4 pcs	Ø8x30mm 1 pcs
<b>D</b>	<b>H-1</b>
	
Ø3.5x14mm 2 pcs	1 pcs

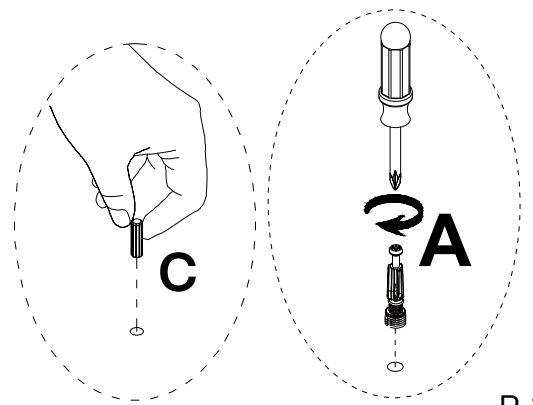
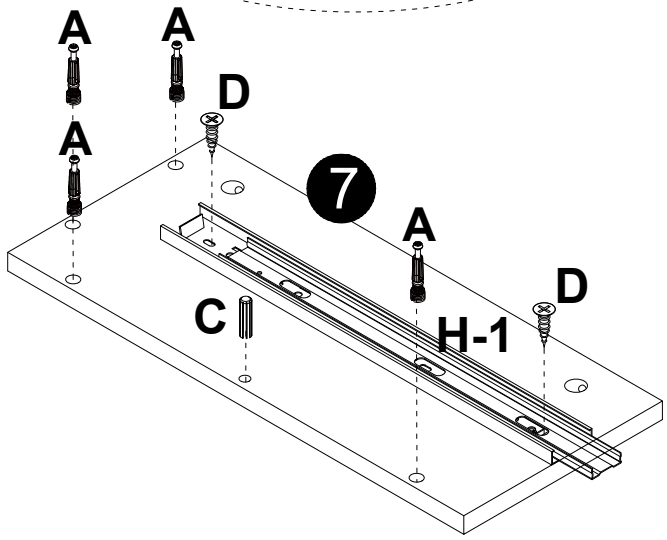

# 11

<b>B</b>

Ø15x12mm
8 pcs

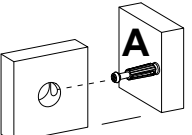
**Step 1**



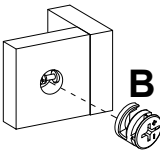

**Step 2**

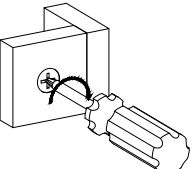
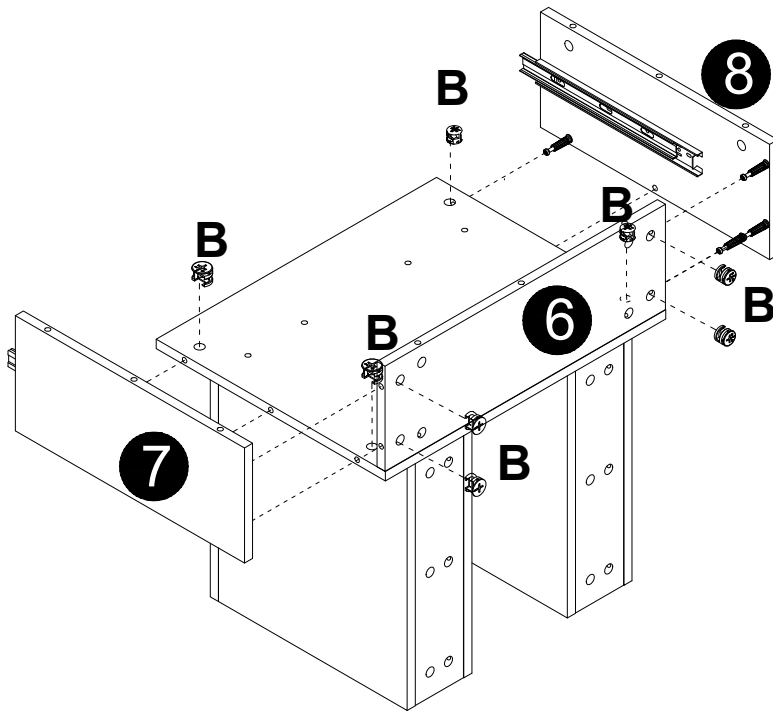

**Step 3**



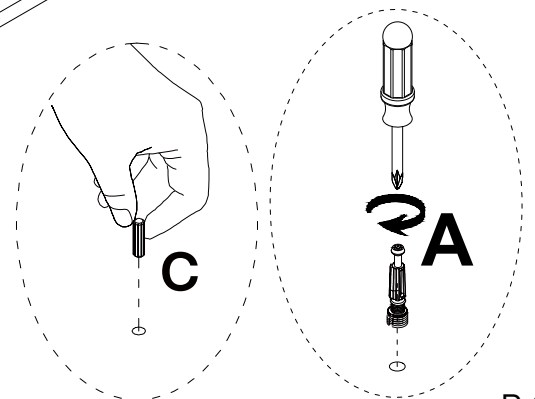
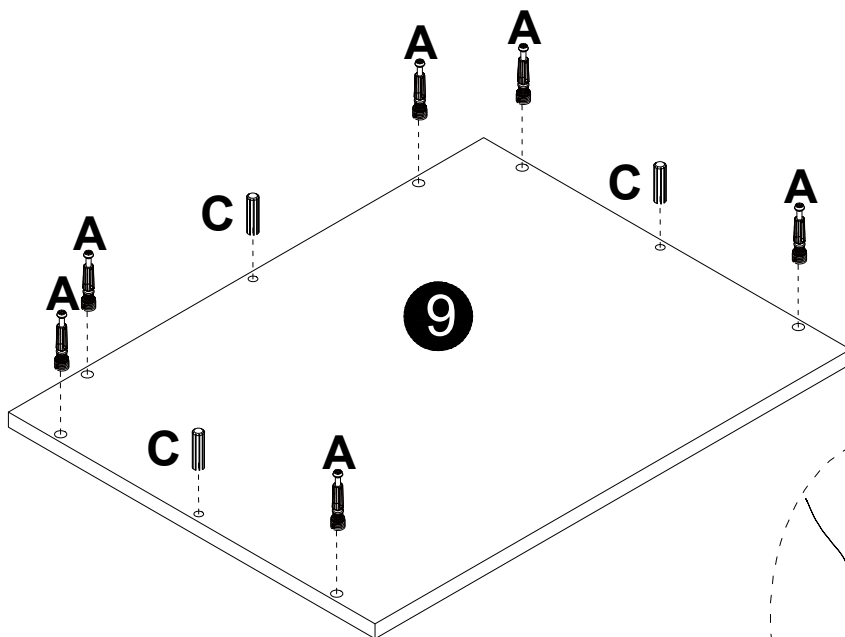

# 12

<b>A</b>	<b>C</b>
	
M6x35mm	Ø8x30mm
6 pcs	3 pcs



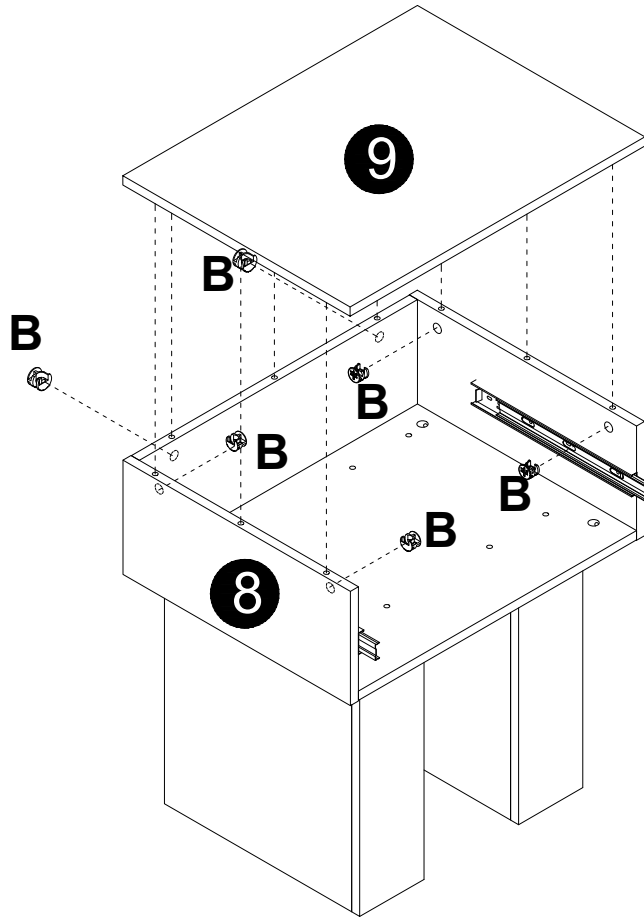
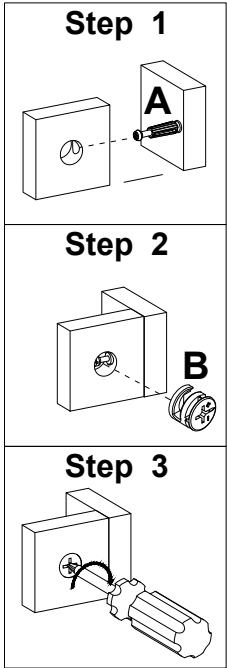

# 13

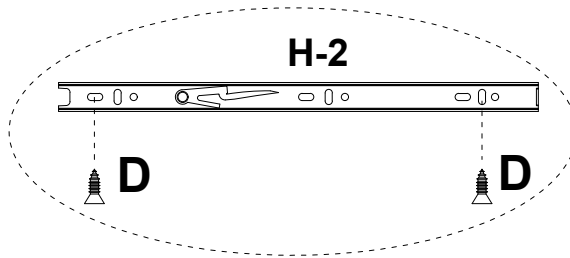

<b>B</b>

Ø15x12mm
6 pcs

# 14

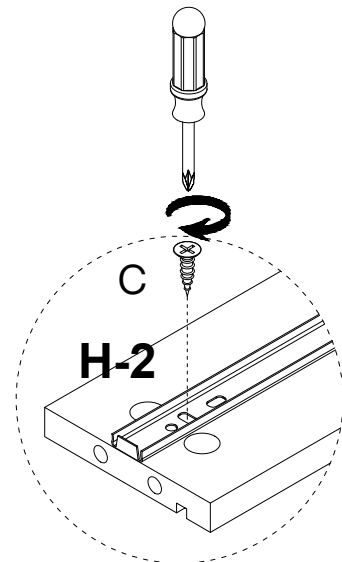
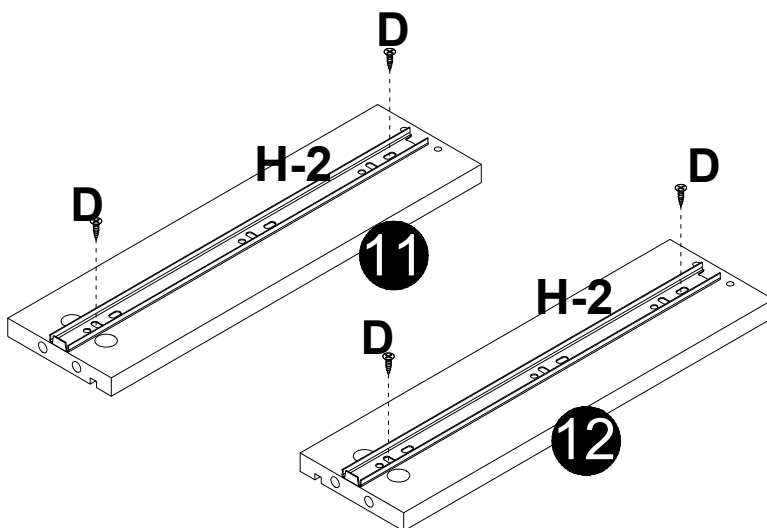

<b>H-2</b>	<b>D</b>
	
2 pcs	Ø3.5x14mm
2 pcs	4 pcs



15

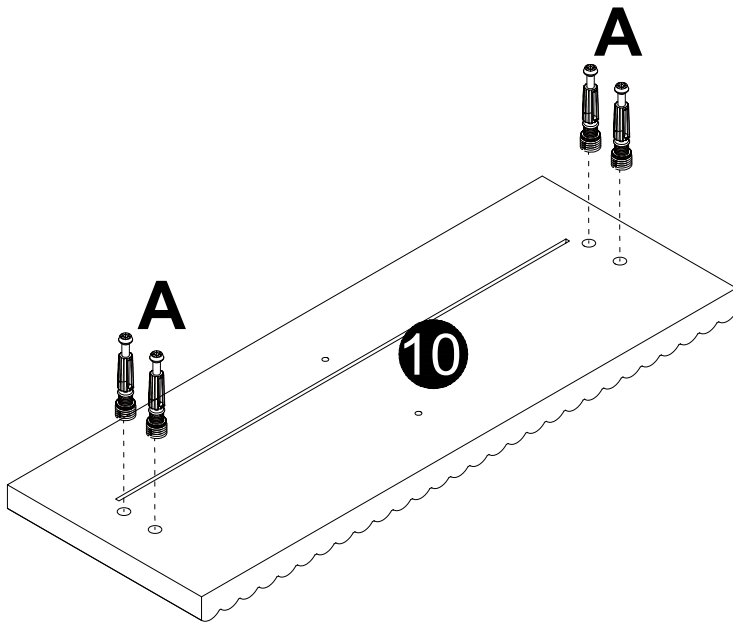

<b>A</b>

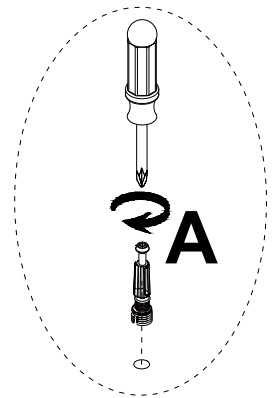
M6x35mm
4 pcs

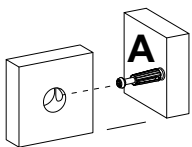

16

**Step 1**



**Step 2**

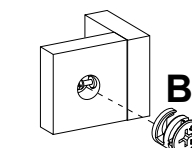

**Step 3**

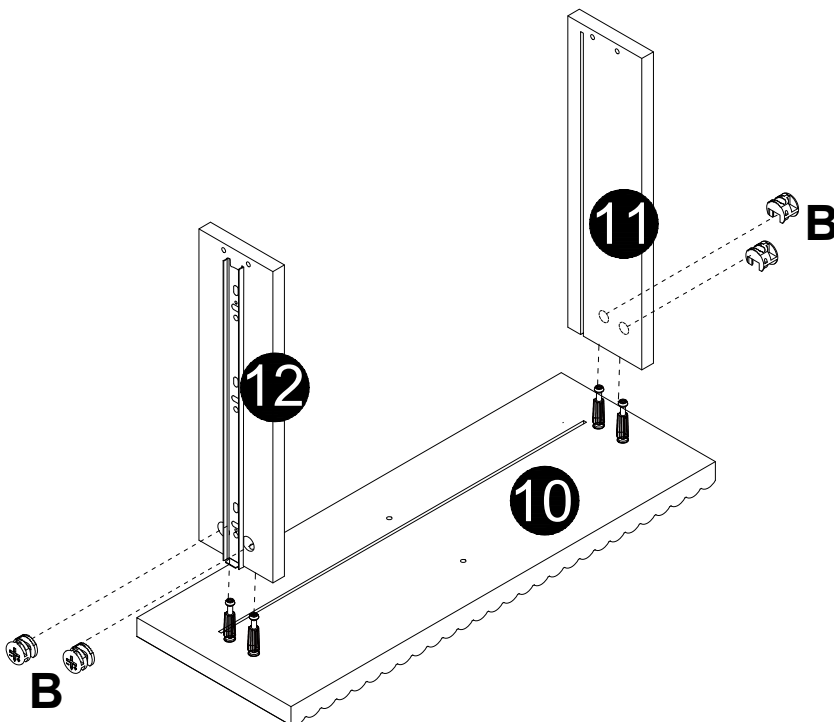
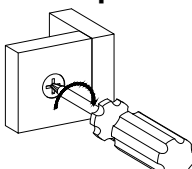

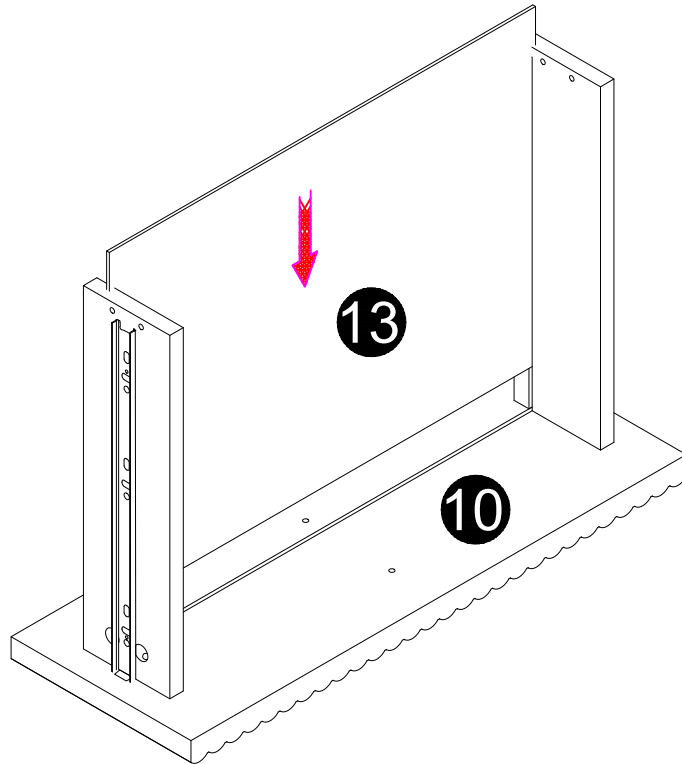

<b>B</b>

Ø15x12mm
4 pcs

17

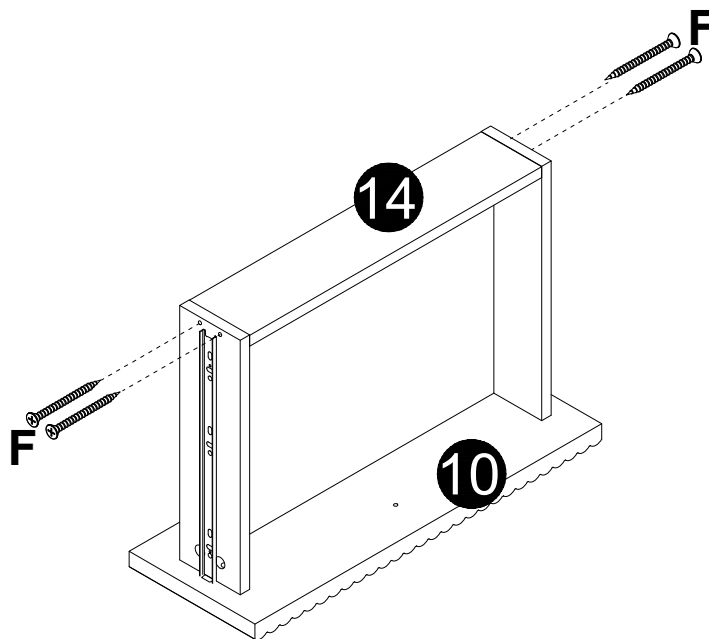

18

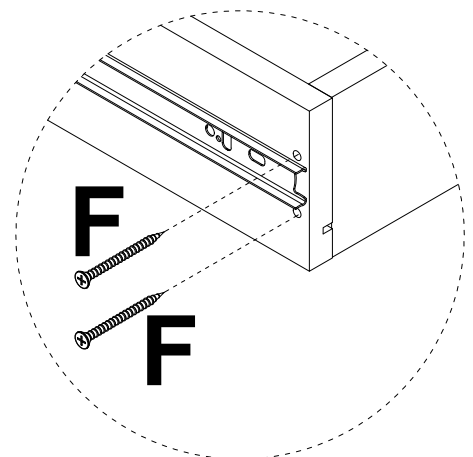

<b>F</b>

Ø3.5x35mm
4 pcs

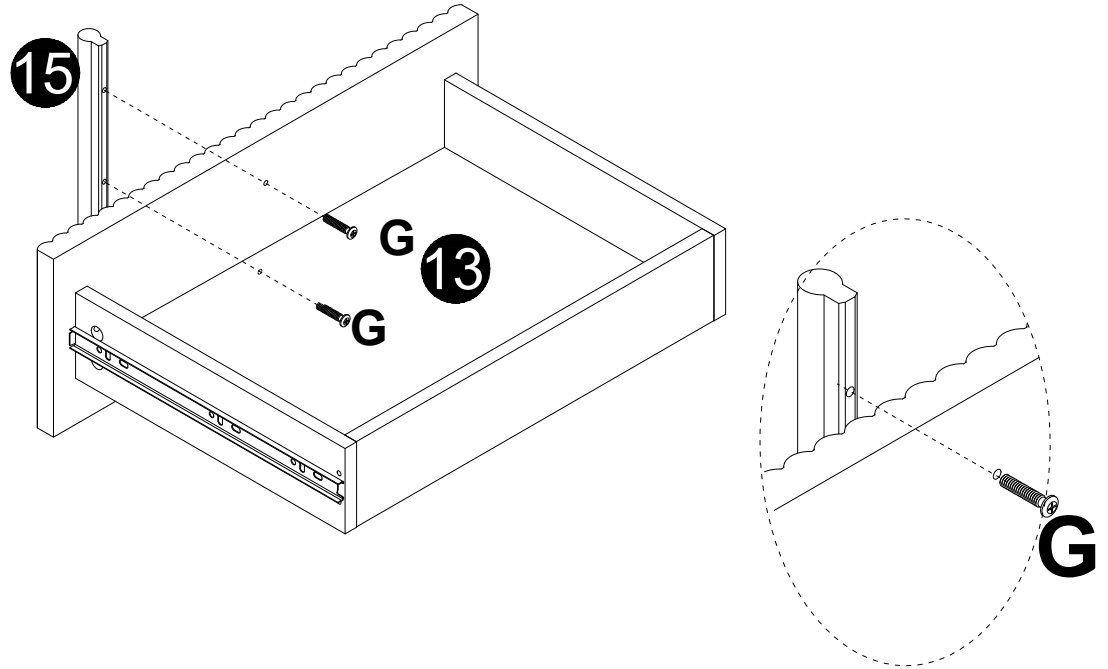

19

<b>G</b>

M4x30mm
2 pcs

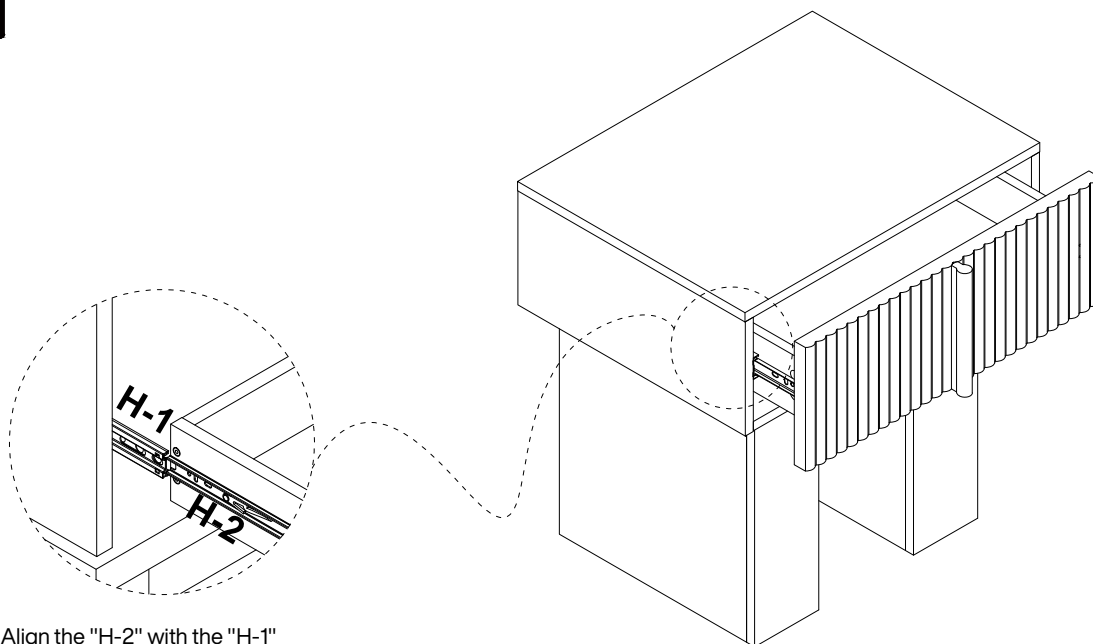

20



Align the "H-2" with the "H-1" guideway and gently push it in to complete the assembly

**Thank you for your support!**

