







ASSEMBLY INSTRUCTIONS & PARTS IDENTIFICATION

DINING CHAIR

Thank you for purchasing this quality product. Be sure to check all packing material carefully for small parts that may have come loose inside the carton during shipment

Parts Key			
No		Qty	Description
1		1Pc	Chair Back
2		1Pc	Complete Seat
3		2Pcs	Front Leg
4		4Pcs	Floor Glide

Hardware kit			
No		Description	Qty
A		Hex nut M8	4 Pcs
B		Lock washer Ø8.5x13mm	11 Pcs
C		Flat washer Ø8.5x19mm	11 Pcs
D		Long bolt Ø6 x 80mm	4 Pcs
E		Short bolt Ø6 x 35mm	3 Pcs
F		Allen key	1 Pc
G		Key wrench	1 Pc

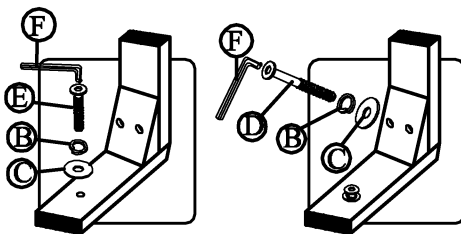

STEP 1

- Carefully lay Chair Back flat on a smooth flat surface to prevent scratches.
- Attach Complete Seat to Chair Back by inserting a Flat Washer, Lock Washer and Short screw into each of the hole on the back of the seat. Tighten screws with provided Allen Key by turning clockwise until secure. (See Detail A).
- Insert a Flat Washer, Lock Washer and Long screw into each of 2 holes in the Complete Seat corners. Tighten screws with provided Key Wrench. (See Detail B).

DETAIL A

DETAIL B

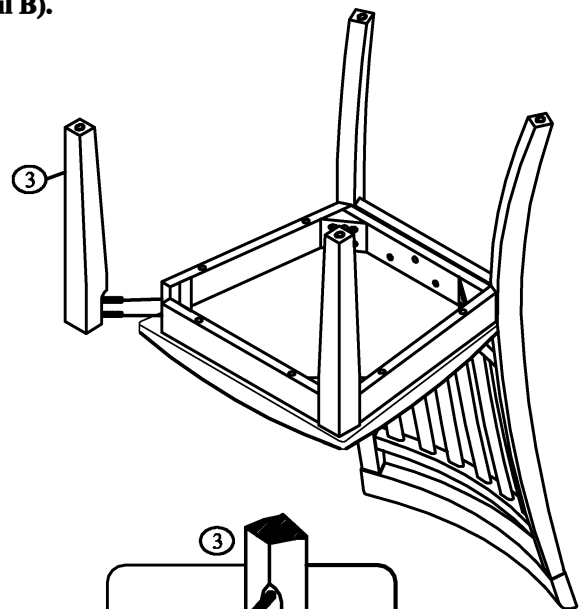
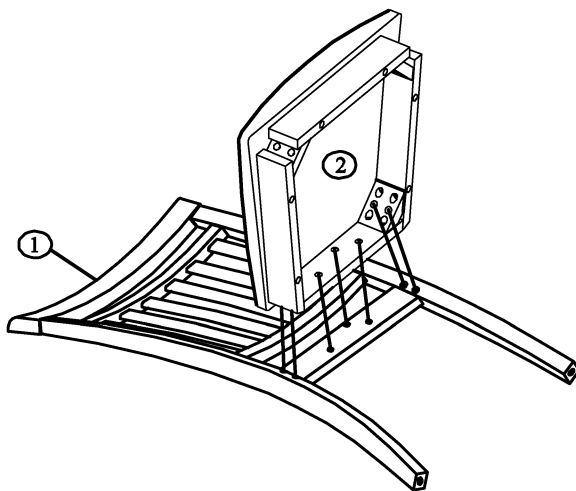

STEP 2

- Carefully turn chair upside down and attach each Leg to the front corners of the Complete Seat. Place Flat Washer, Lock Washer and Nut on each leg bolt, tightening the Nut on each Leg using provided Key Wrench. (See Detail C).
- Be sure to level the chair prior to tightening all the nuts/screws

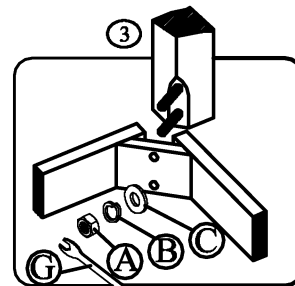

DETAIL C