



# **ASSEMBLY INSTRUCTIONS**

# NOTICE

IMPORTANT, RETAIN FOR FUTURE REFERENCE: READ CAREFULLY

WICHTIG, FÜR SPÄTERE NACHSCHLAGE AUFBEWAHREN: SORGFÄLTIG LESEN

IMPORTANTE, GUARDAR PARA REFERENCIA FUTURA: LEER ATENTAMENTE

IMPORTANTE, CONSERVARE PER RIFERIMENTI FUTURI: LEGGERE ATTENTAMENTE

IMPORTANT, À CONSERVER POUR RÉFÉRENCE FUTURE : LIRE ATTENTIVEMENT

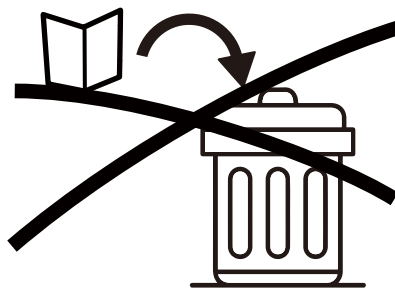
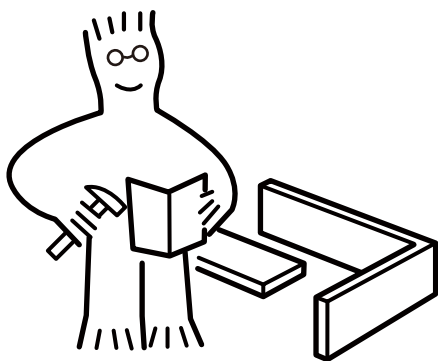

Assemble on a flat, clean and soft surface.

Auf einer flachen, sauberen und weichen Oberfläche zusammenbauen.

Assembler sur une surface plate, propre et douce.

Assemblare su una superficie piatta, pulita e morbida.

Ensamblar sobre una superficie plana, limpia y suave.

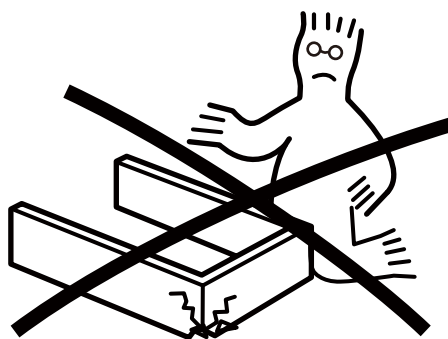
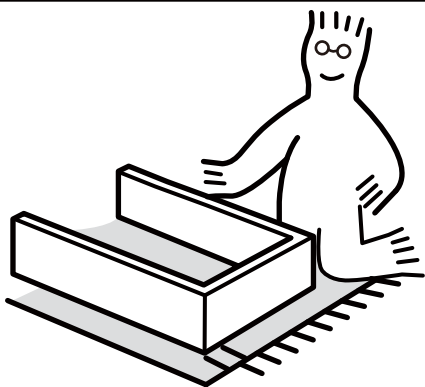

Professional installation is highly recommended.

Eine professionelle Installation wird dringend empfohlen.

Une installation professionnelle est fortement recommandée.

Si raccomanda vivamente l'installazione professionale.

Se recomienda altamente la instalación profesional.



Periodically check that all components are tightly secured.

Überprüfen Sie Regelmäßig, Dass Alle Komponenten Fest Gesichert Sind.

Vérifiez Périodiquement Que Tous Les Composants Sont Bien Fixés.

Controllare Periodicamente Che Tutti I Componenti Siano Ben Fissati.

Verifique Periódicamente Que Todos Los Componentes Estén Bien Asegurados.

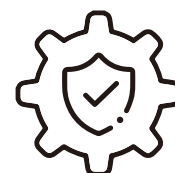

It is recommended that multiple people assemble this product.

Es wird empfohlen, dass mehrere Personen dieses Produkt zusammenbauen.

Il est recommandé que plusieurs personnes assemblent ce produit.

Si raccomanda che più persone assemblino questo prodotto.

Se recomienda que varias personas ensamblen este producto.

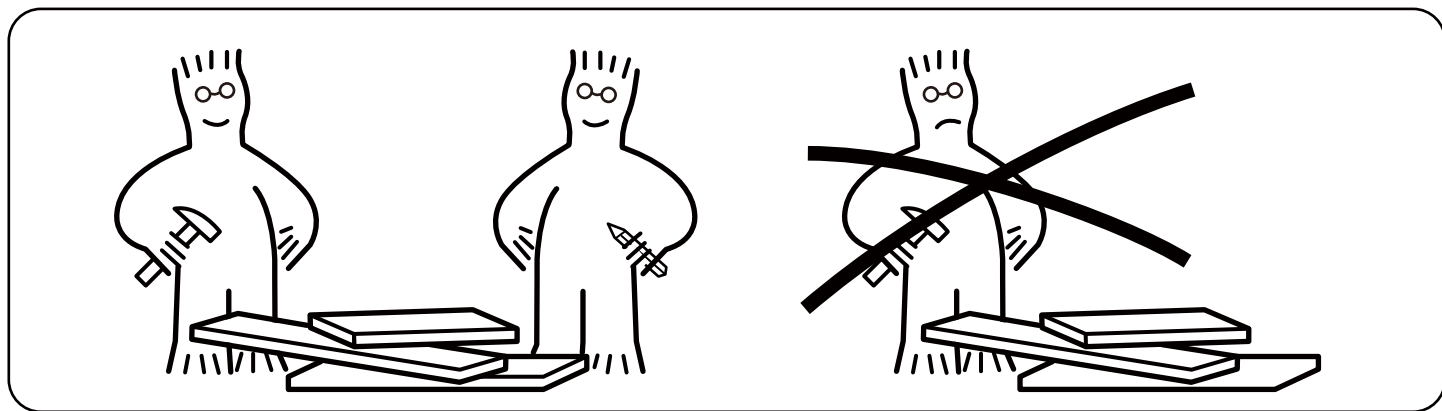

Please have the following auxiliary tools ready:

Bitte halten Sie folgende Hilfswerkzeuge bereit:

Veuillez préparer les outils auxiliaires suivants :

Si prega di avere pronti i seguenti strumenti ausiliari:

Por favor, tenga listas las siguientes herramientas auxiliares:

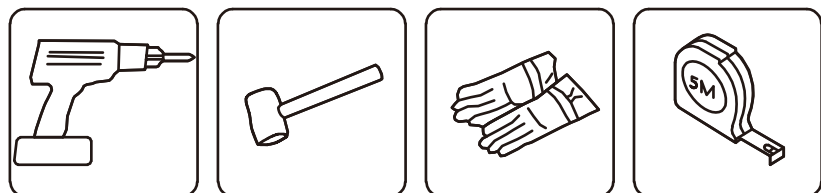

**USING CAM LOCK AND QUICKFIT**  
**VERWENDUNG VON NOCKENSCHLOSS UND QUICKFIT**  
**UTILISATION DE SERRURE À CAME ET QUICKFIT**  
**USO DI SERRATURA A LEVA E QUICKFIT**  
**USANDO EL CIERRE DE LEVA Y QUICKFIT**

Tighten QuickFit until the shoulder is flush with the panel. Do not overtighten or undertighten.  
 Ziehen Sie den Quickfit an, bis die Schulter bündig mit der Platte ist. Nicht zu fest oder zu locker anziehen.  
 Serrez le quickfit jusqu'à ce que l'épaulement soit affleurant avec le panneau. Ne serrez pas trop ou trop peu.  
 Stringere il quickfit fino a quando la spalla è a filo con il pannello. Non stringere troppo o troppo poco.  
 Apriete el quickfit hasta que el hombro esté al ras con el panel. No apriete demasiado ni demasiado poco.

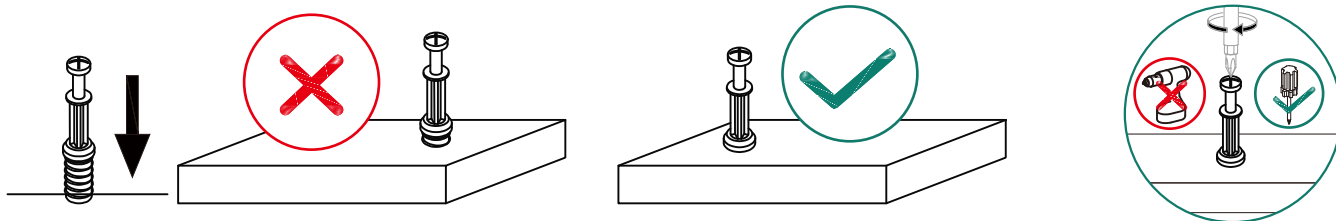

When fitting the cam lock, ensure the starting position is correct before inserting the connecting QuickFit.

Stellen Sie beim Einbau des nockenschloss sicher, dass die Startposition korrekt ist, bevor Sie den verbindenden Quickfit einsetzen.

Lors de la pose du serrure à came, assurez-vous que la position de départ est correcte avant d'insérer le quickfit de connexion.

Quando si monta il serratura a leva, assicurarsi che la posizione di partenza sia corretta prima di inserire il quickfit di collegamento.

Al instalar el cierre de leva, asegúrese de que la posición inicial sea correcta antes de insertar el quickfit de conexión.

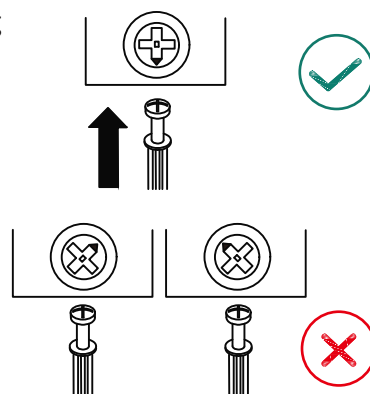

The QuickFit head should be in the center of the cam lock when the two panels are joined. The cam lock should be inserted before the QuickFit. Turn the cam lock clockwise to tighten.

Der Quickfit-Kopf sollte sich in der Mitte des nockenschloss befinden, wenn die beiden Platten verbunden sind. Der nockenschloss sollte vor dem Quickfit eingesetzt werden. Drehen Sie den nockenschloss im Uhrzeigersinn, um ihn zu befestigen.

La tête du quickfit doit être au centre du serrure à came lorsque les deux panneaux sont assemblés. Le serrure à came doit être inséré avant le quickfit. Tournez le serrure à came dans le sens des aiguilles d'une montre pour le serrer.

La testa del quickfit dovrebbe essere al centro del serratura a leva quando i due pannelli sono uniti. Il serratura a leva deve essere inserito prima del quickfit. Ruotare il serratura a leva in senso orario per stringere.



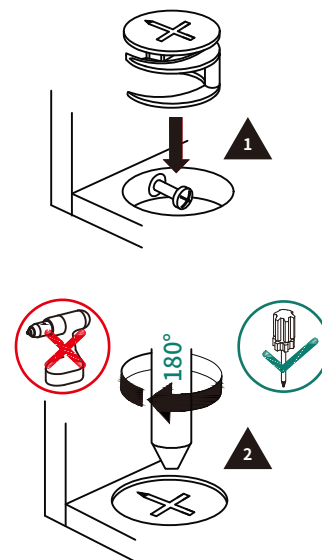

La cabeza del quickfit debe estar en el centro del cam lock cuando los dos paneles estén unidos. El cierre de leva debe insertarse antes del quickfit. Gire el cierre de leva en sentido horario para apretar.

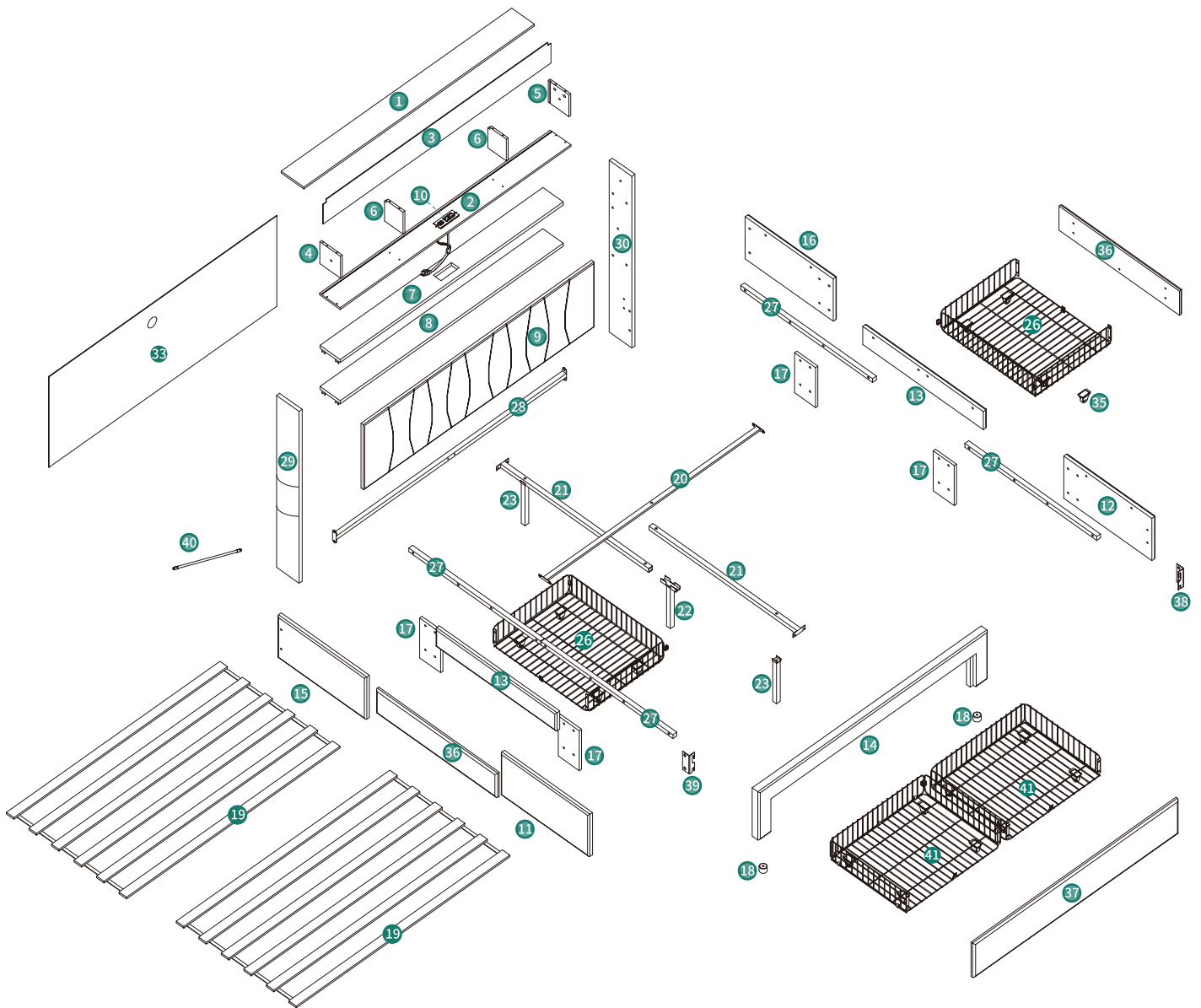



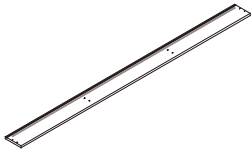
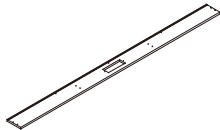
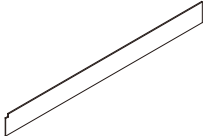
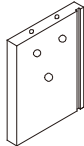
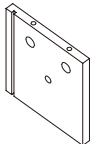
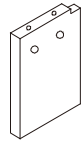
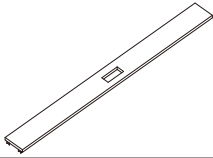
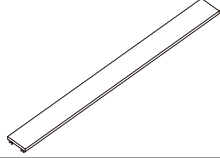
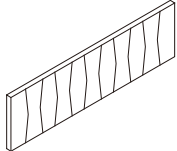

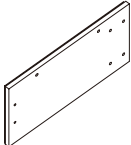
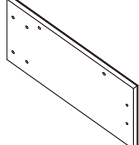
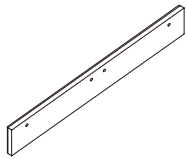
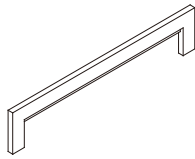
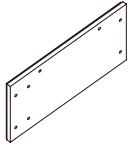
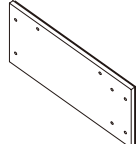
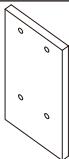

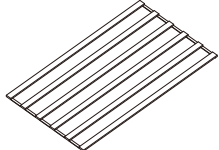
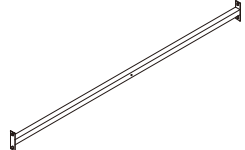

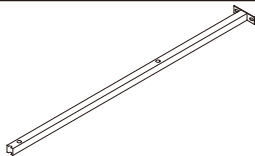
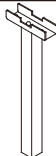

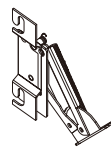

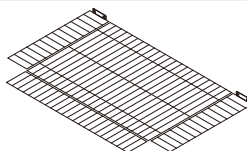
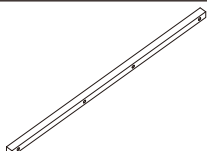
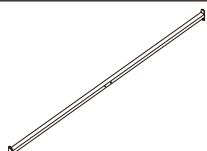

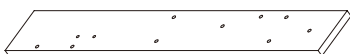
# EXPLODED VIEW

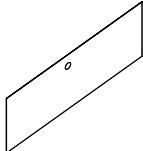

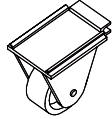
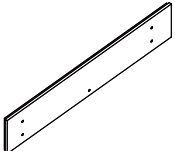
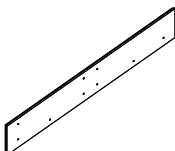
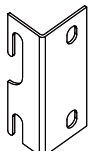

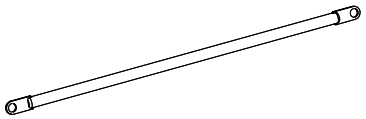

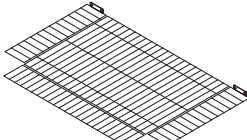
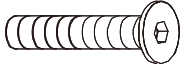
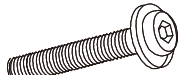
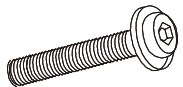
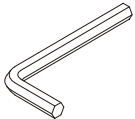
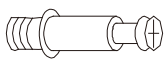
# PARTS

Item no. Nr. N° d'article Articolo No. Artículo No.	Reference Image Referenzbild Image de référence Immagine di riferimento Imagen de referencia	Qty. Menge Qté. Qtà Cant.	Item no. Nr. N° d'article Articolo No. Artículo No.	Reference Image Referenzbild Image de référence Immagine di riferimento Imagen de referencia	Qty. Menge Qté. Qtà Cant.
1		X1	2		X1
3		X1	4		X1
5		X1	6		X2
7		X1	8		X1
9		X1	10		X1
11		X1	12		X1
13		X2	14		X1
15		X1	16		X1
17		X4	18		X2
19		X2	20		X1

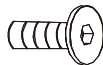
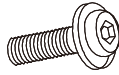
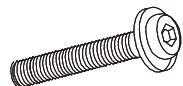
Item no. Nr. N° d'article Articolo No. Artículo No.	Reference Image Referenzbild Image de référence Immagine di riferimento Imagen de referencia	Qty. Menge Qté. Qtà Cant.	Item no. Nr. N° d'article Articolo No. Artículo No.	Reference Image Referenzbild Image de référence Immagine di riferimento Imagen de referencia	Qty. Menge Qté. Qtà Cant.
21		X2	22		X1
23		X2	24		X1
25		X1	26		X2
27		X4	28		X1
29		X1	30		X1
31		X8	32		X4
33		X1	34		X1
35		X16	36		X2
37		X1	38		X1
39		X1	40		X2

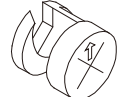
Item no. Nr. N° d'article Articolo No. Artículo No.	Reference Image Referenzbild Image de référence Immagine di riferimento Imagen de referencia	Qty. Menge Qté. Qtà Cant.
41		X2
B	 M6X35mm	X2
D	 M8X30mm	X22 + 2extra
F	 M8X40mm	X5
H	 5#	X1
J		X8
L	 4#	X1

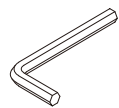
Item no. Nr. N° d'article Articolo No. Artículo No.	Reference Image Referenzbild Image de référence Immagine di riferimento Imagen de referencia	Qty. Menge Qté. Qtà Cant.
A	 M6X15mm	X32 + 2extra
C	 M8X15mm	X24 + 2extra
E	 M8X35mm	X16 + 2extra
G	 ST4X13mm	X2
I		X8
K	 M5X35mm	X8
M	 3#	X1

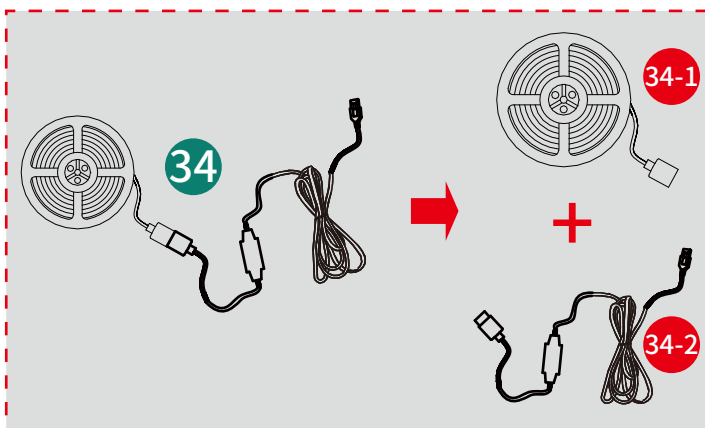

# ASSEMBLY

**1**

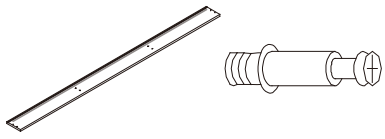

① 1pc

ⓐ 8pcs

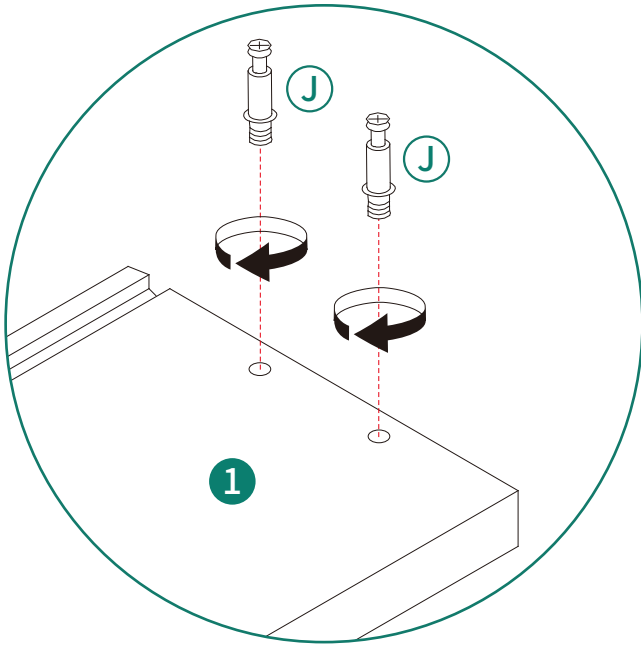
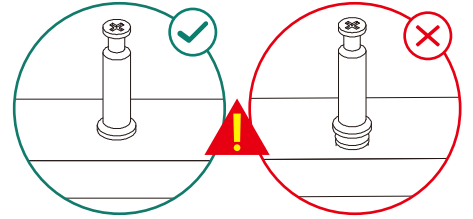

Hook-and-loop fastener  
Klettverschluss  
Velcro  
Velcro  
Velcro

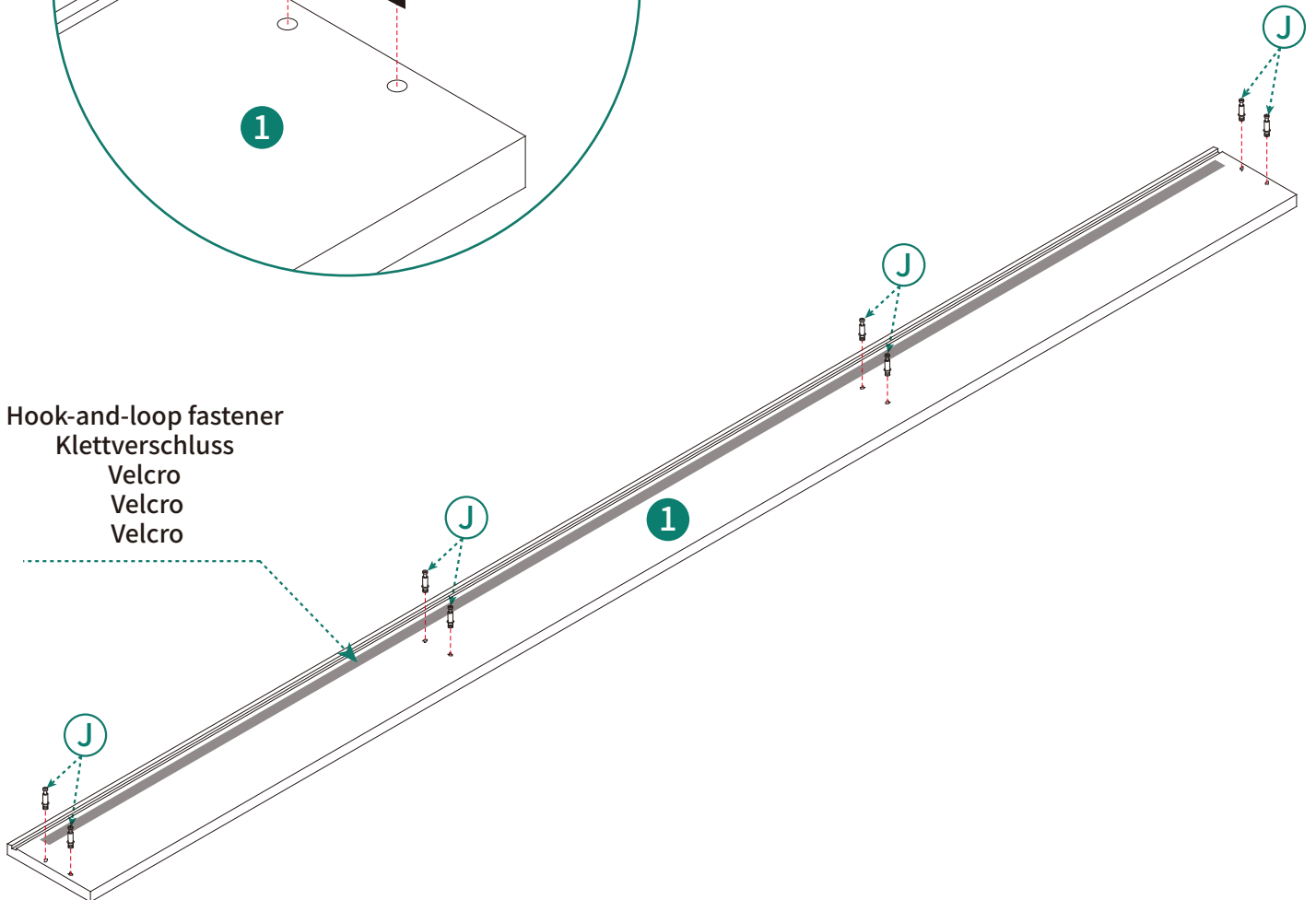

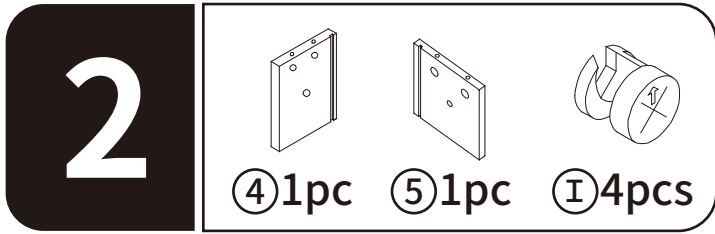

Note: Make sure the positions marked by triangles are facing the same direction.

Hinweis: Stellen Sie sicher, dass die Positionen, die durch Dreiecke markiert sind, in die gleiche Richtung zeigen.

Note : Assurez-vous que les positions marquées par des triangles sont orientées dans la même direction.

Nota: Assicuratevi che le posizioni contrassegnate da triangoli siano rivolte nella stessa direzione.

Nota: Asegúrate de que las posiciones marcadas con triángulos estén orientadas en la misma dirección.

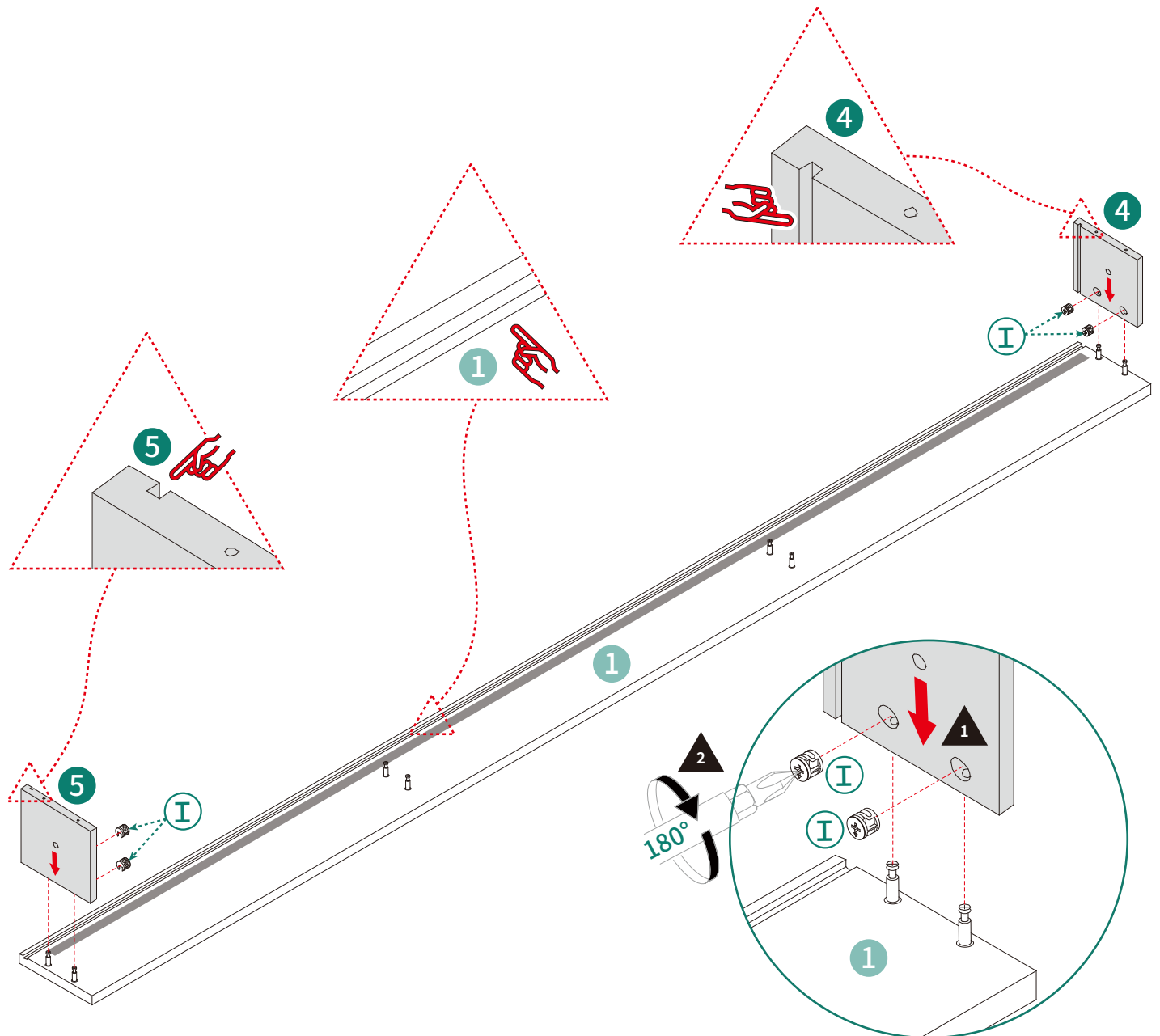

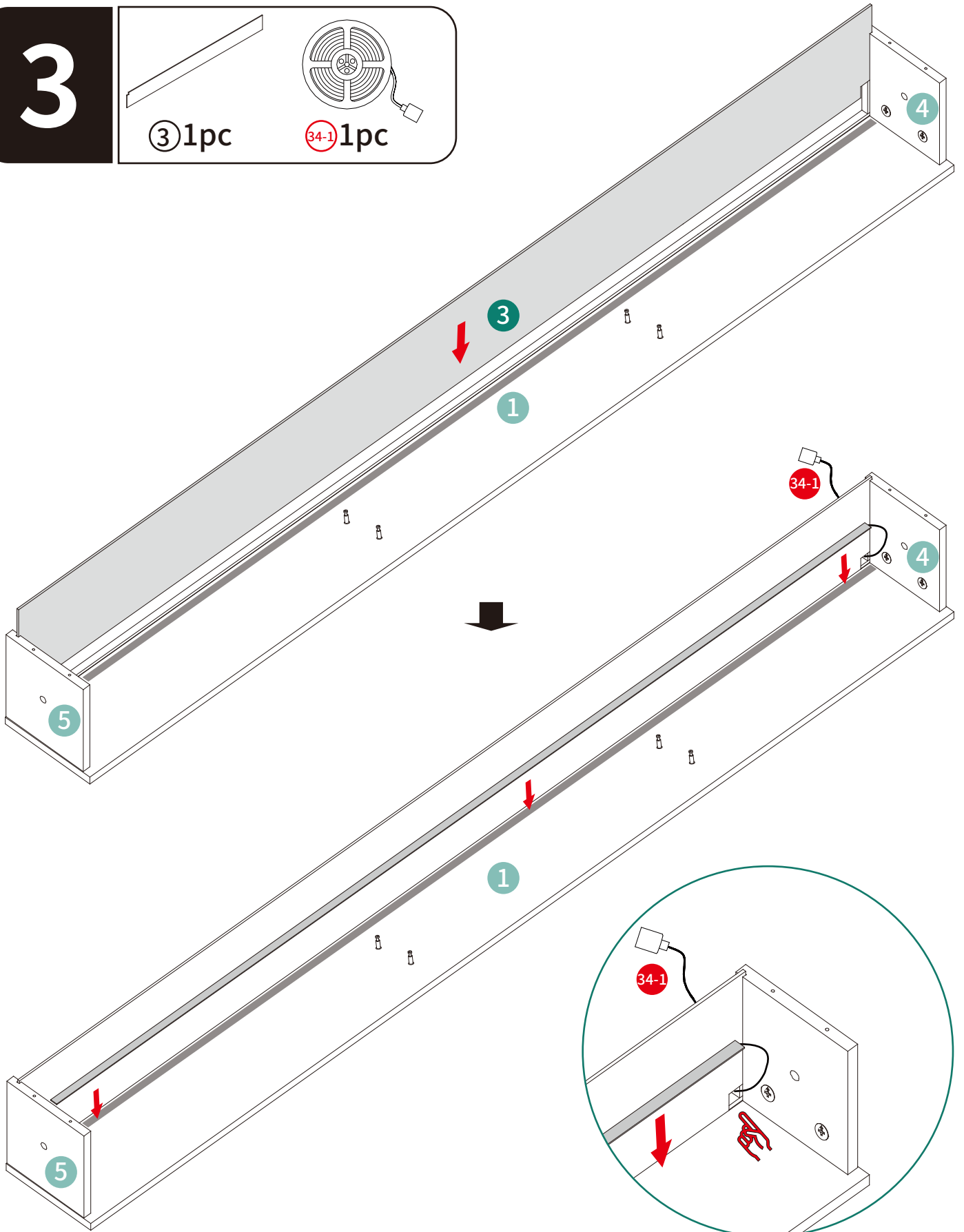
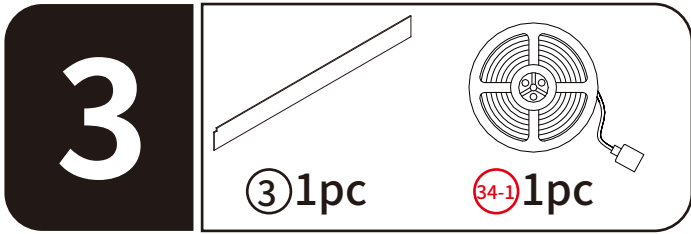

**4**

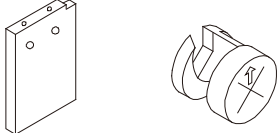

⑥ 2pcs    ① 4pcs

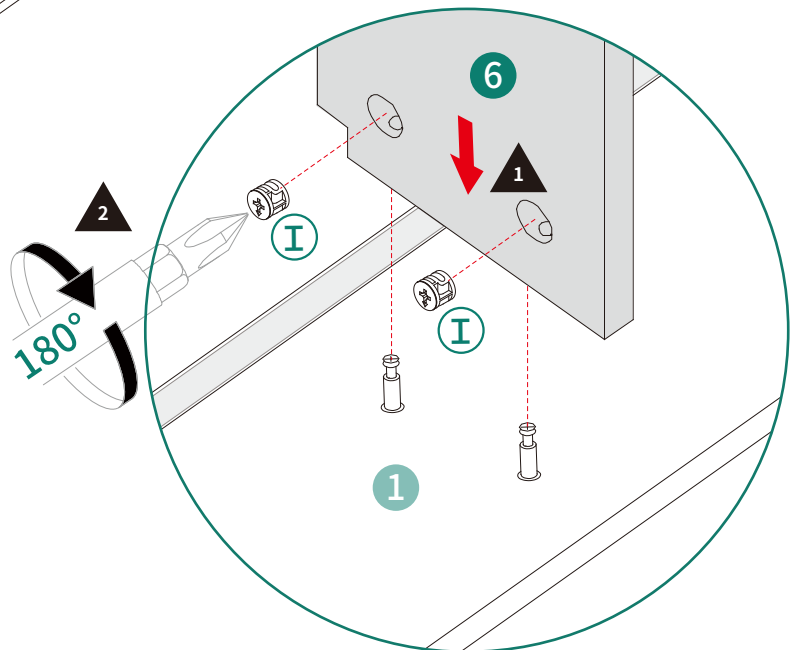
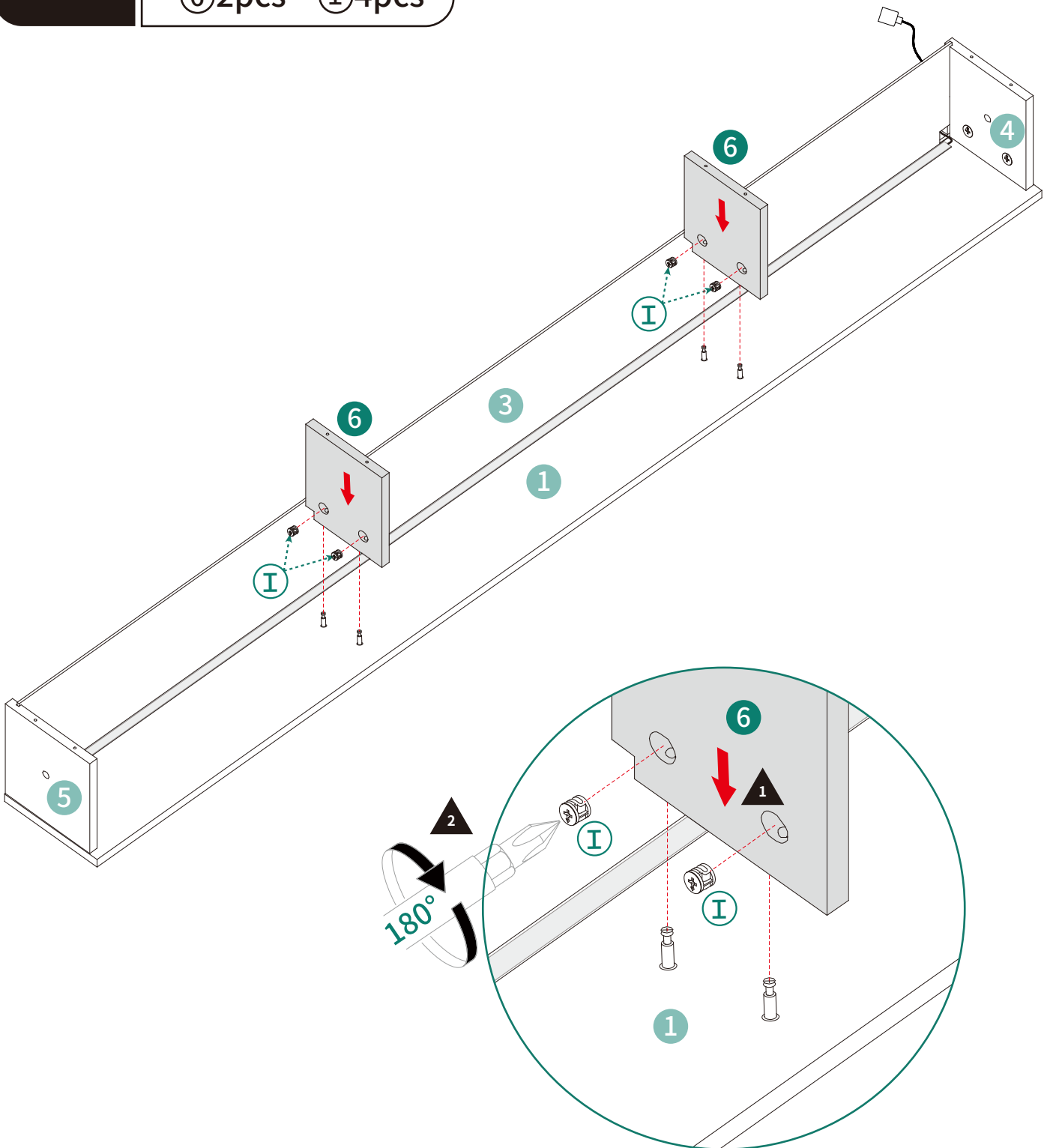

5

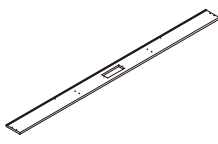

② 1pc

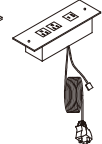

⑩ 1pc

ST4X13mm



Ⓒ 2pcs

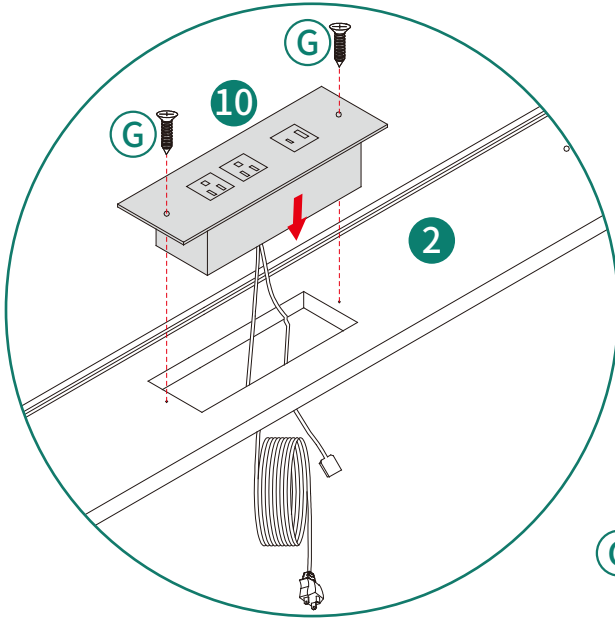
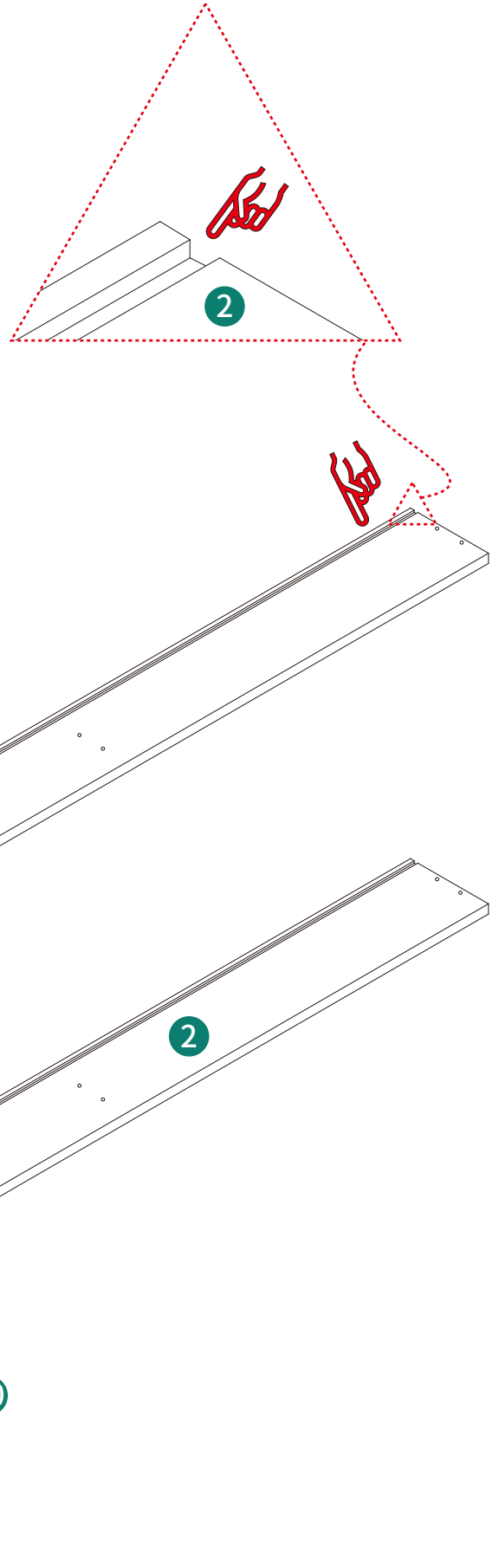

**6**

M5X35mm



Ⓚ 8pcs

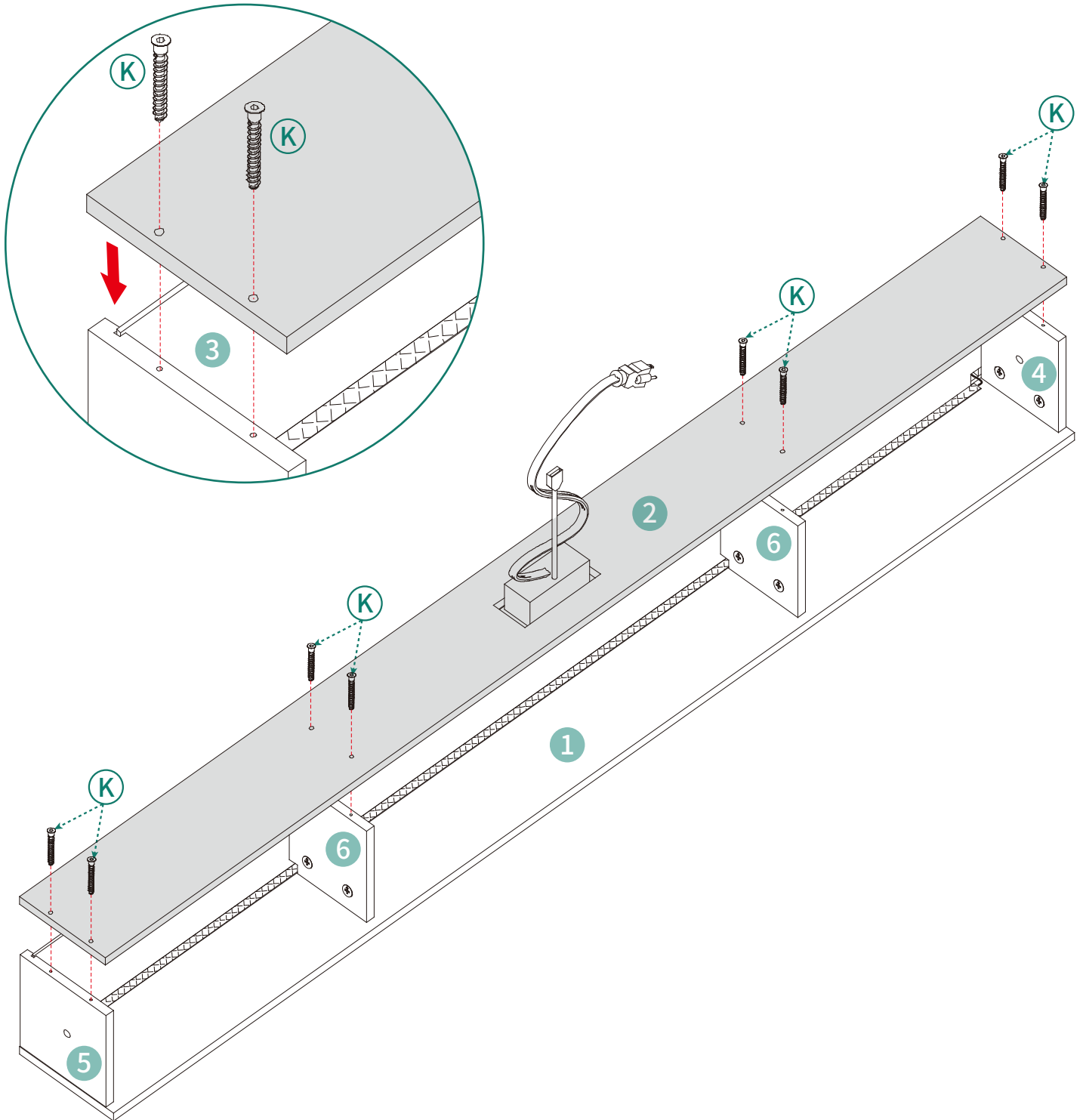



# 8

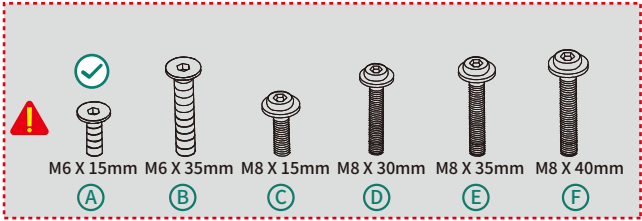
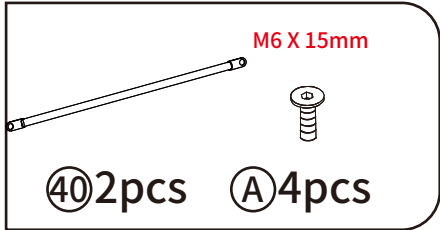

Hook-and-loop fastener  
Klettverschluss  
Velcro  
Velcro  
Velcro

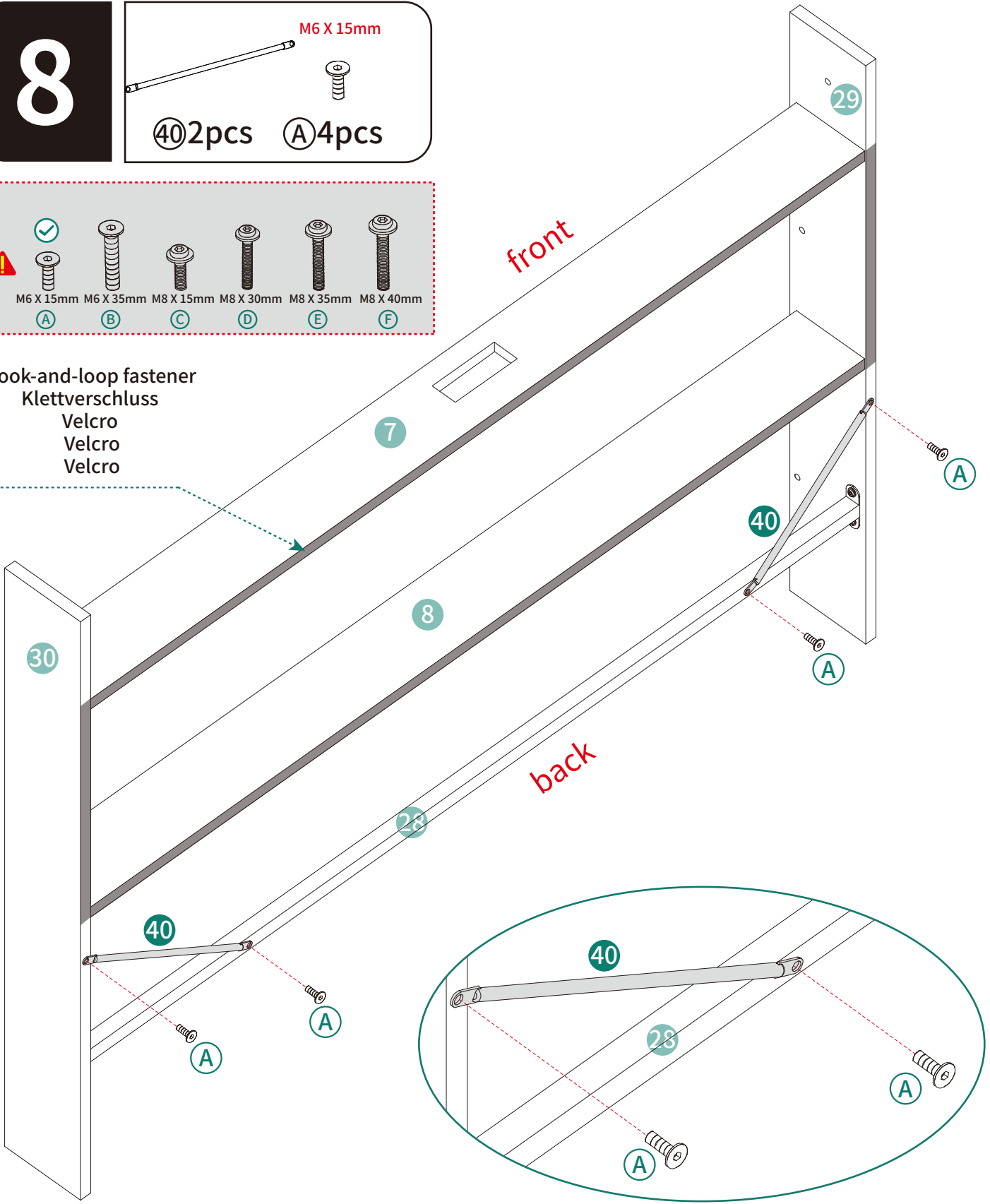

# 9

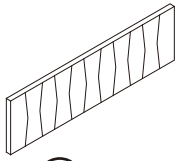

⑨ 1pc

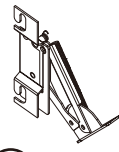

②④ 1pc



②⑤ 1pc

M6 X 15mm  
Ⓐ 4pcs

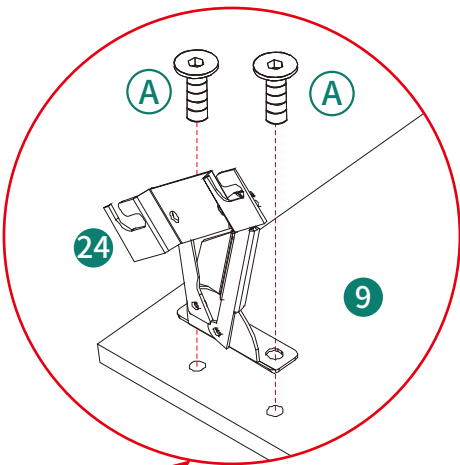
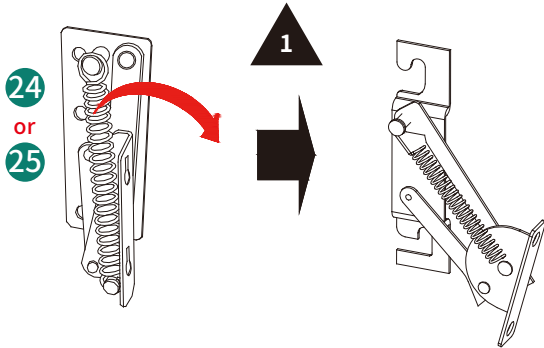
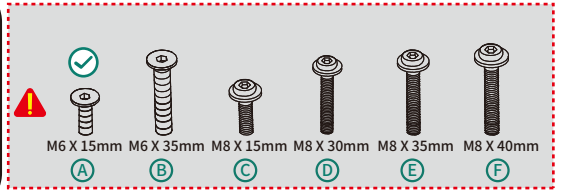

2

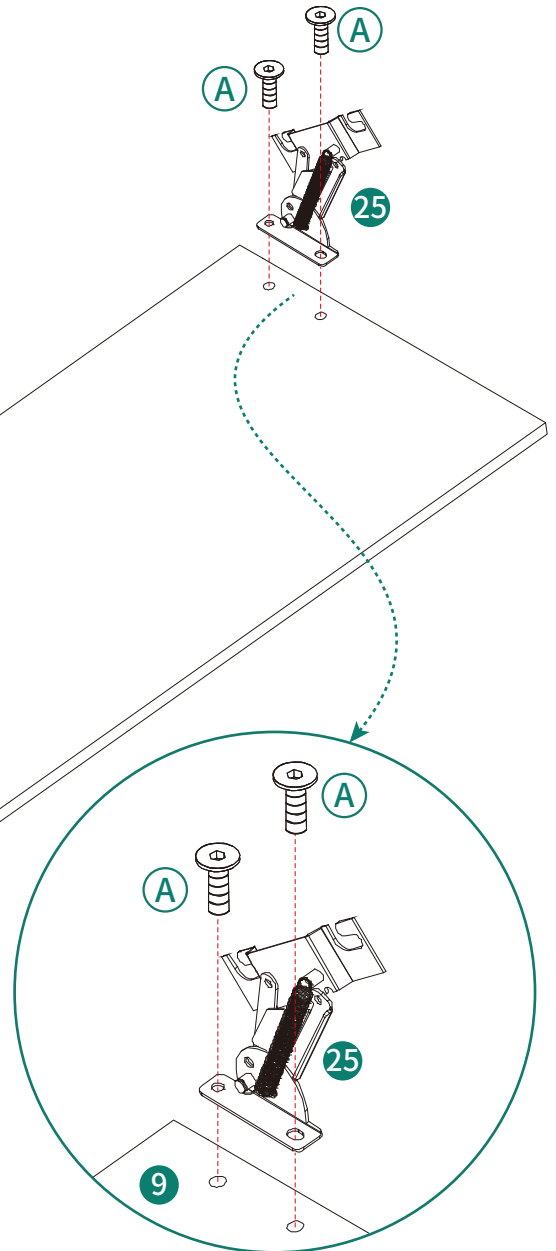
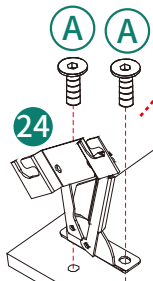







**10**

M6 X 15mm



(A) 4pcs

M6 X 15mm M6 X 35mm M8 X 15mm M8 X 30mm M8 X 35mm M8 X 40mm

(A) (B) (C) (D) (E) (F)

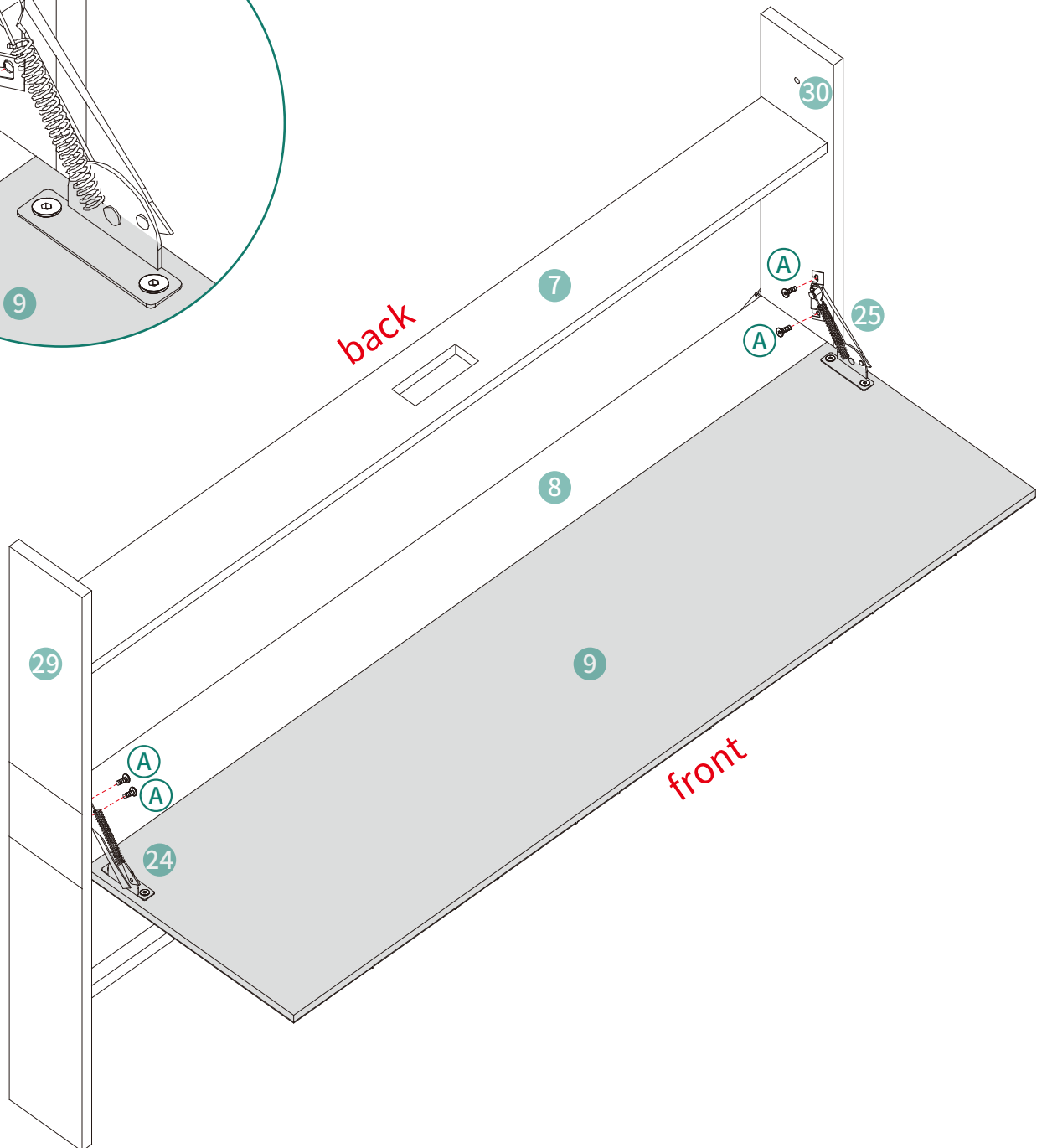
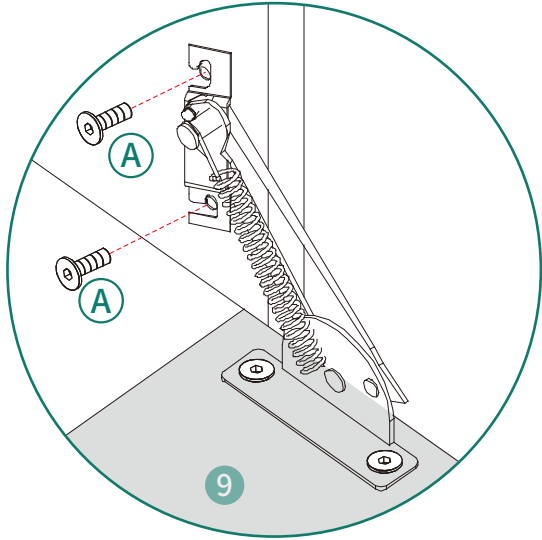

# 11

M8 X 30mm



(D) 2pcs

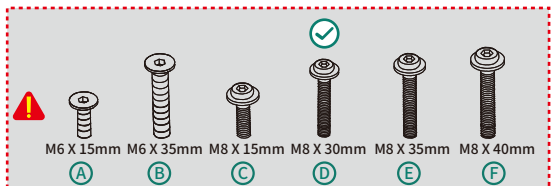
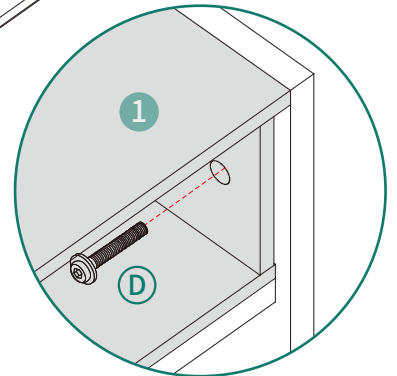
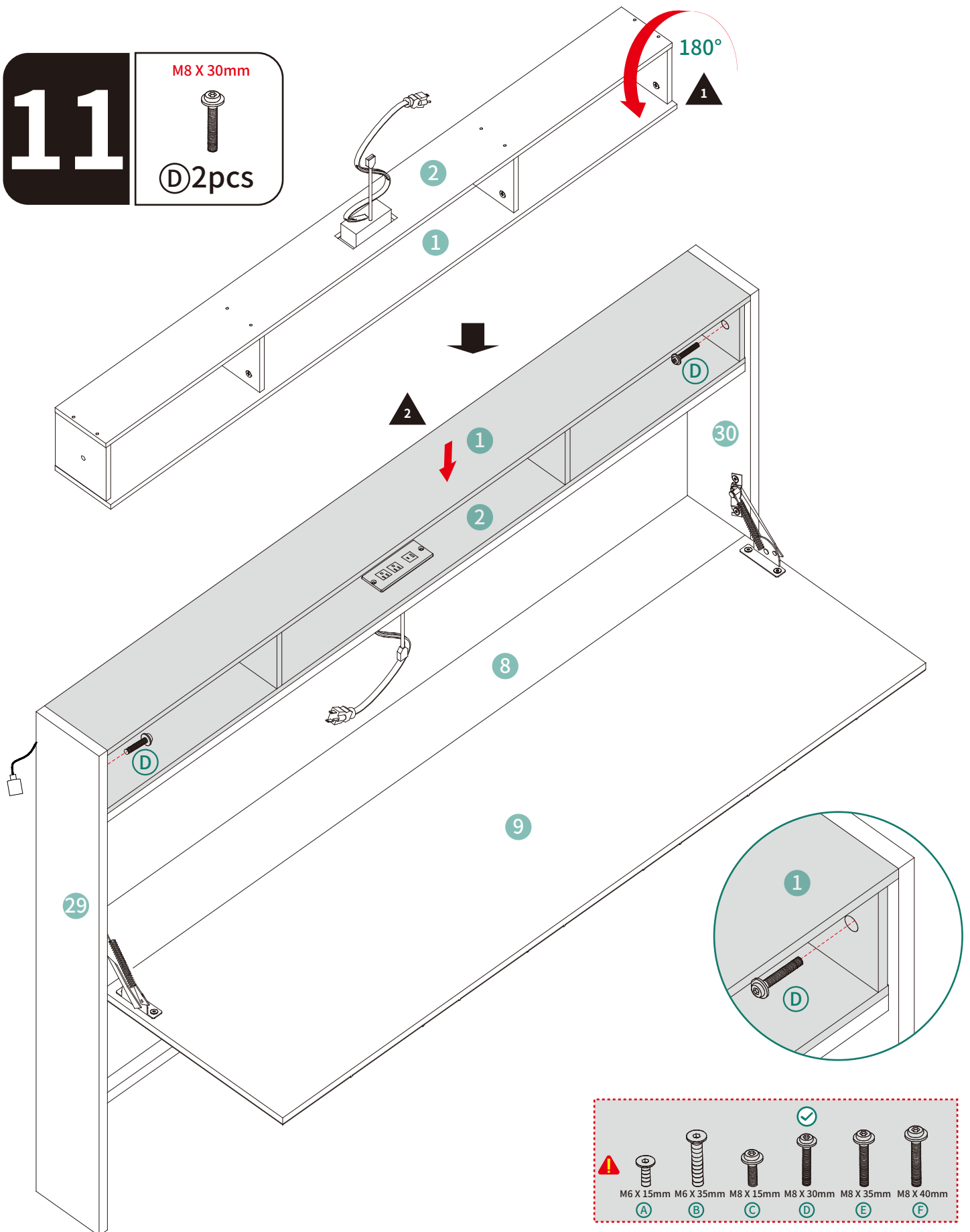

# 12

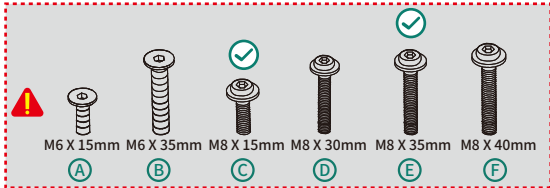
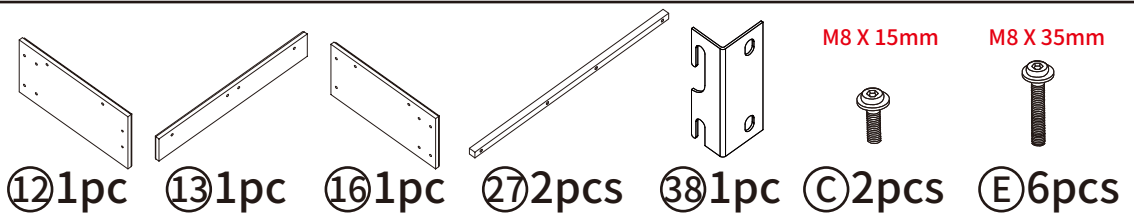

**Note: Do not place screws here in this step.**  
**Hinweis: In diesem Schritt keine Schrauben hier platzieren.**  
**Remarque : Ne placez pas de vis ici à cette étape.**  
**Nota: Non posizionare viti qui in questo passaggio.**  
**Nota: No coloque tornillos aquí en este paso.**

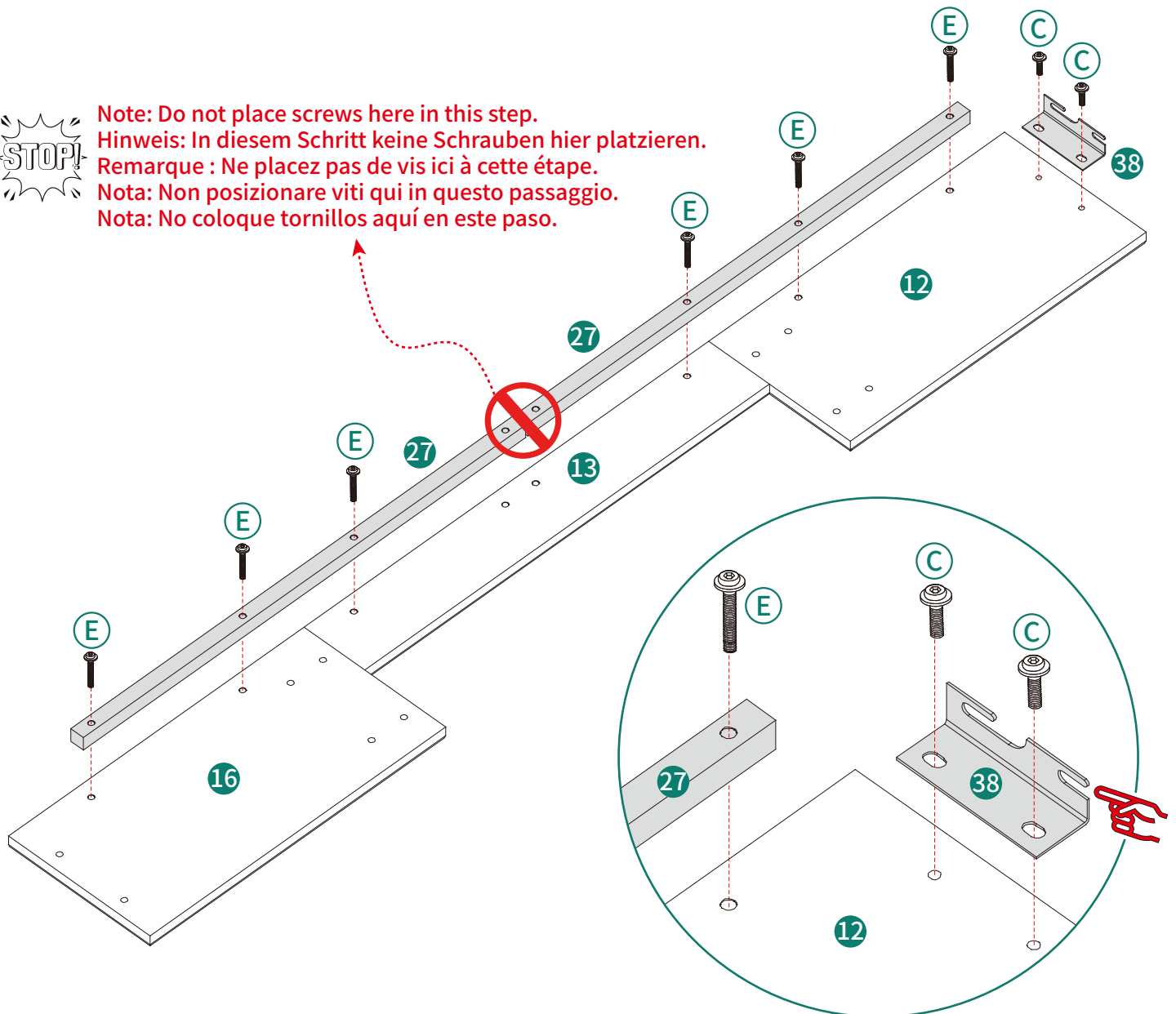

# 13



M8 X 30mm  
17 2pcs    D 8pcs

⚠ M6 X 15mm M6 X 35mm M8 X 15mm M8 X 30mm M8 X 35mm M8 X 40mm

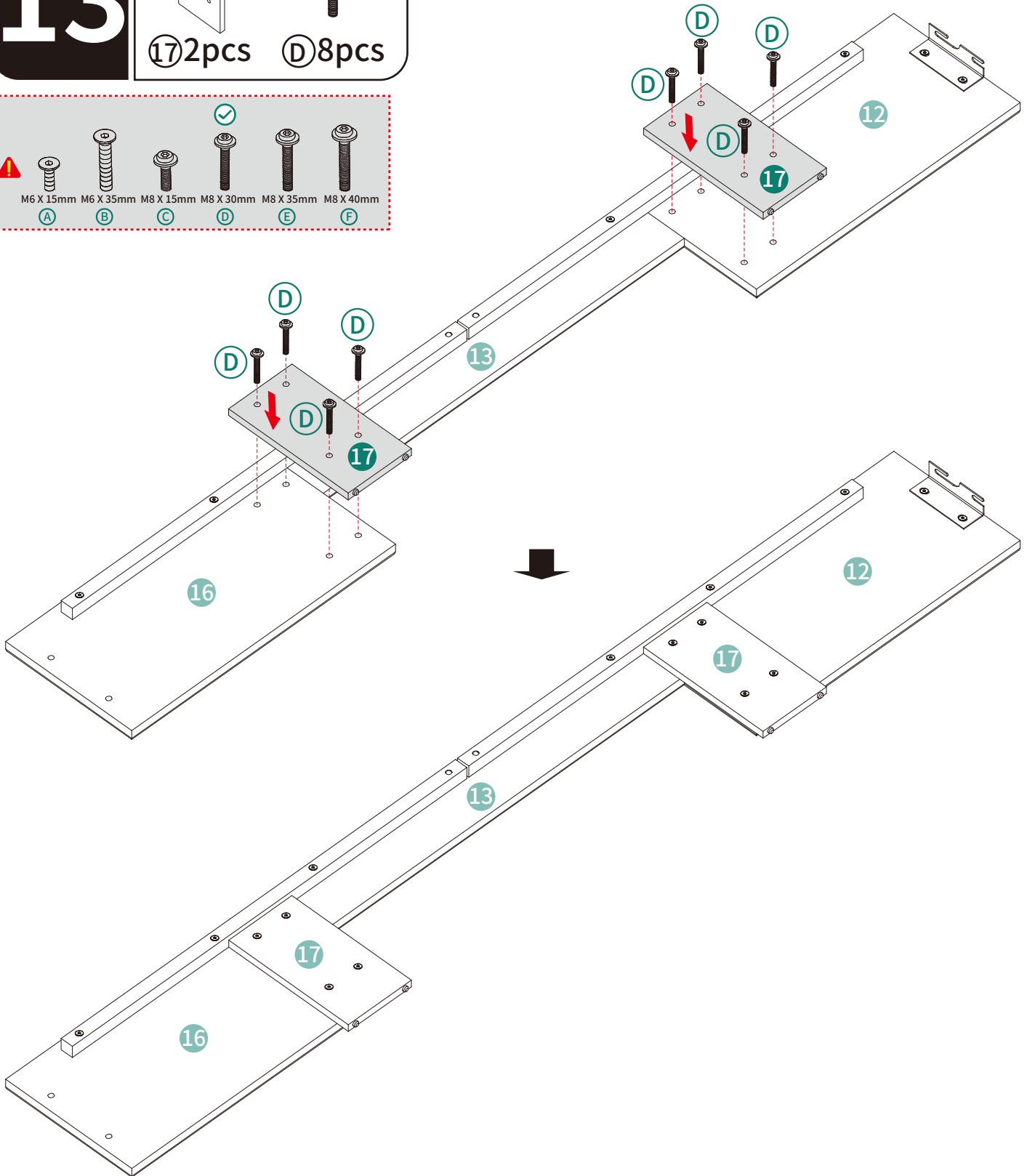
A B C D E F

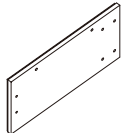
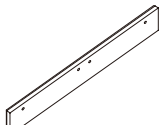
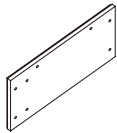
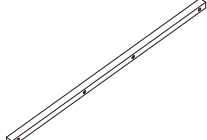
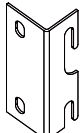

# 14

-  ⑪1pc
-  ⑬1pc
-  ⑮1pc
-  ⑳2pcs
-  ㉔1pc
-  M8 X 15mm ㉒2pcs
-  M8 X 35mm ㉓6pcs

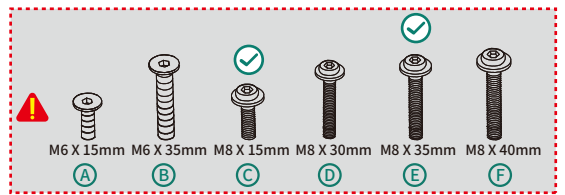

**STOP!**

**Note: Do not place screws here in this step.**  
**Hinweis: In diesem Schritt keine Schrauben hier platzieren.**  
**Remarque : Ne placez pas de vis ici à cette étape.**  
**Nota: Non posizionare viti qui in questo passaggio.**  
**Nota: No coloque tornillos aquí en este paso.**

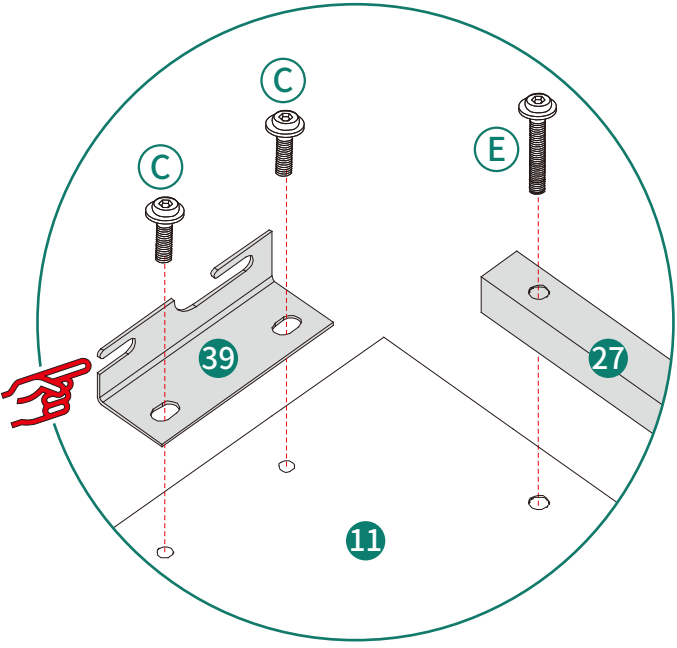
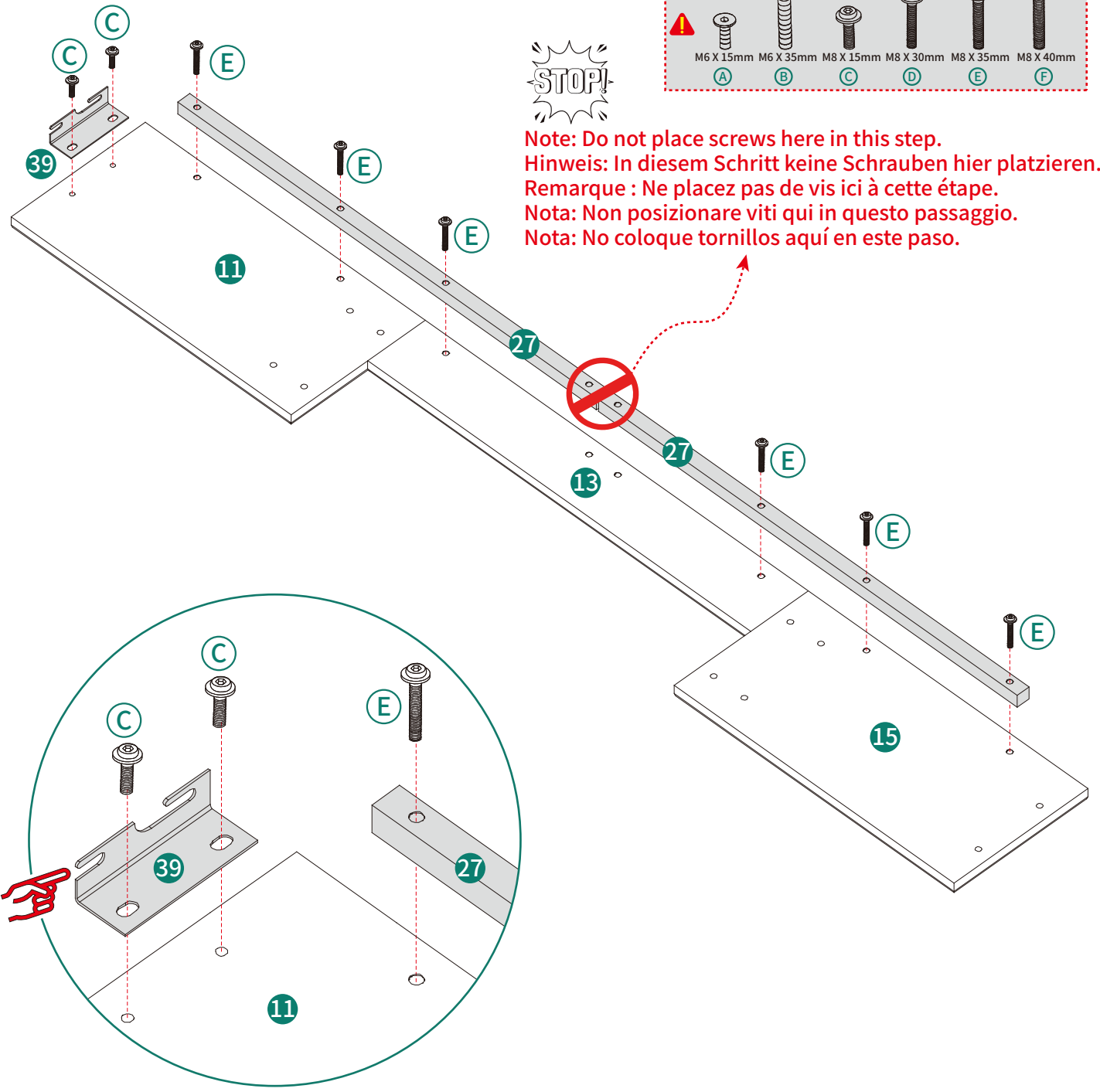

# 15

M8 X 30mm

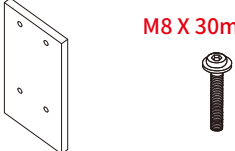

17 2pcs    D 8pcs

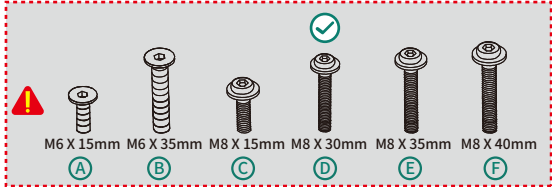

A B C D E F

M6 X 15mm M6 X 35mm M8 X 15mm M8 X 30mm M8 X 35mm M8 X 40mm

⚠️ ✓

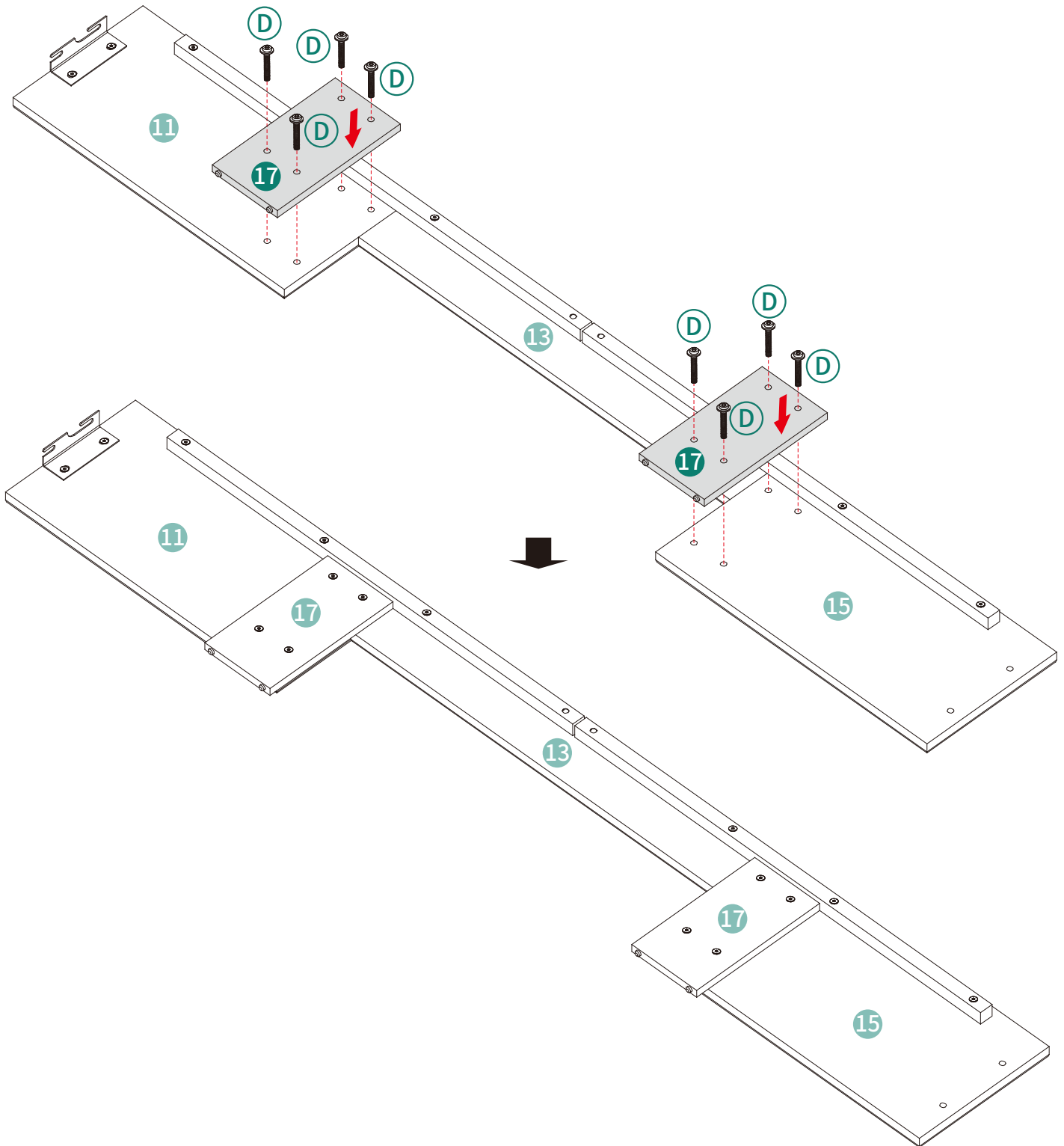

# 16

M8 X 30mm



(D) 4pcs

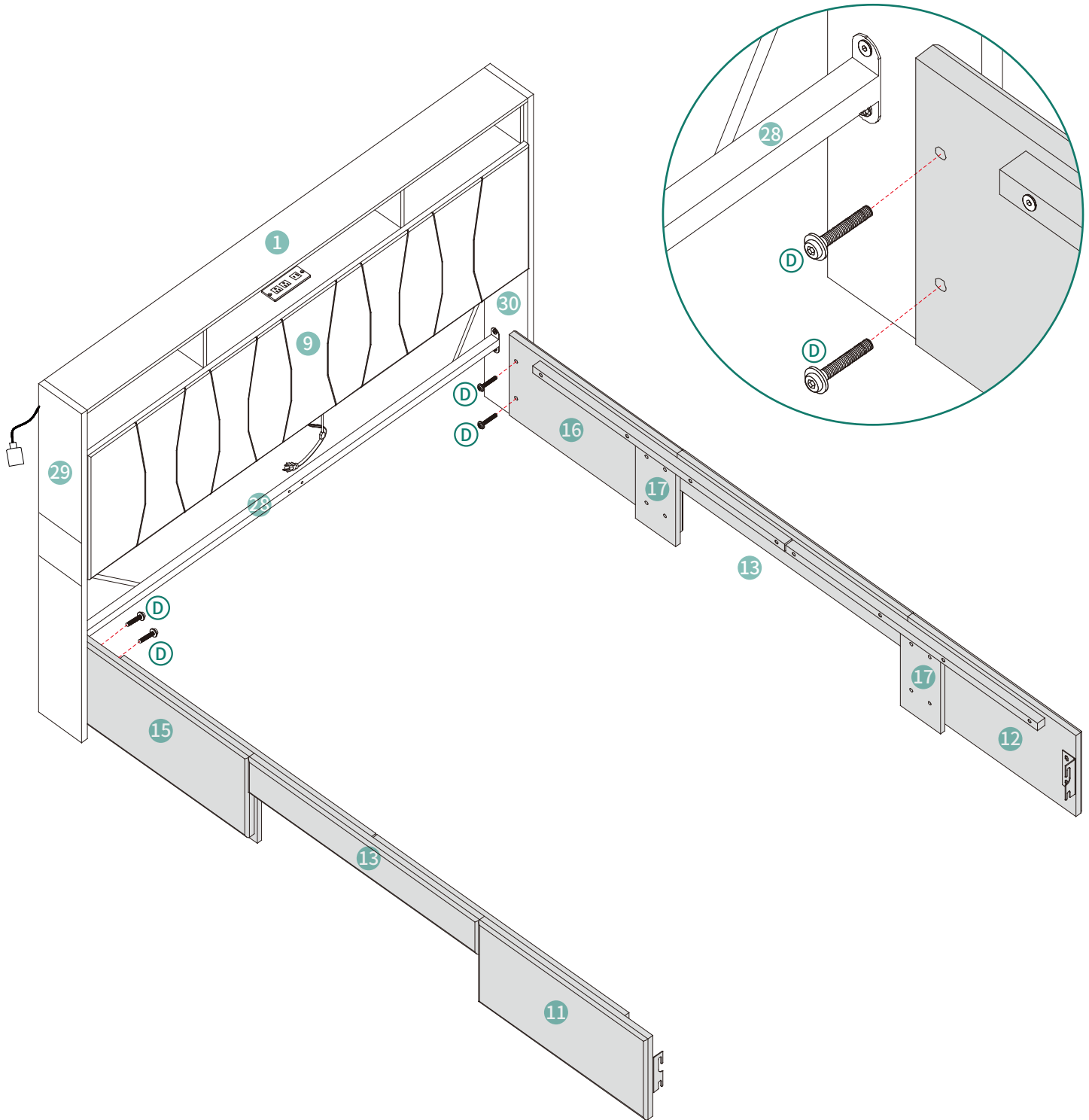
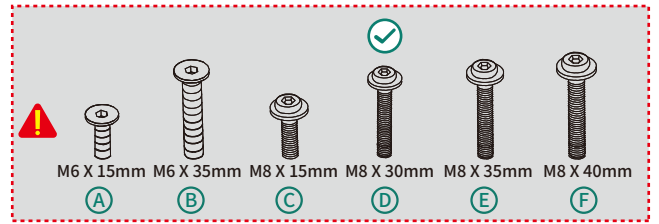

# 17

M6 X 35mm

⑭ 1pc    ⑱ 2pcs    ② 2pcs

⚠    ✓

M6 X 15mm    M6 X 35mm    M8 X 15mm    M8 X 30mm    M8 X 35mm    M8 X 40mm

①    ②    ③    ④    ⑤    ⑥

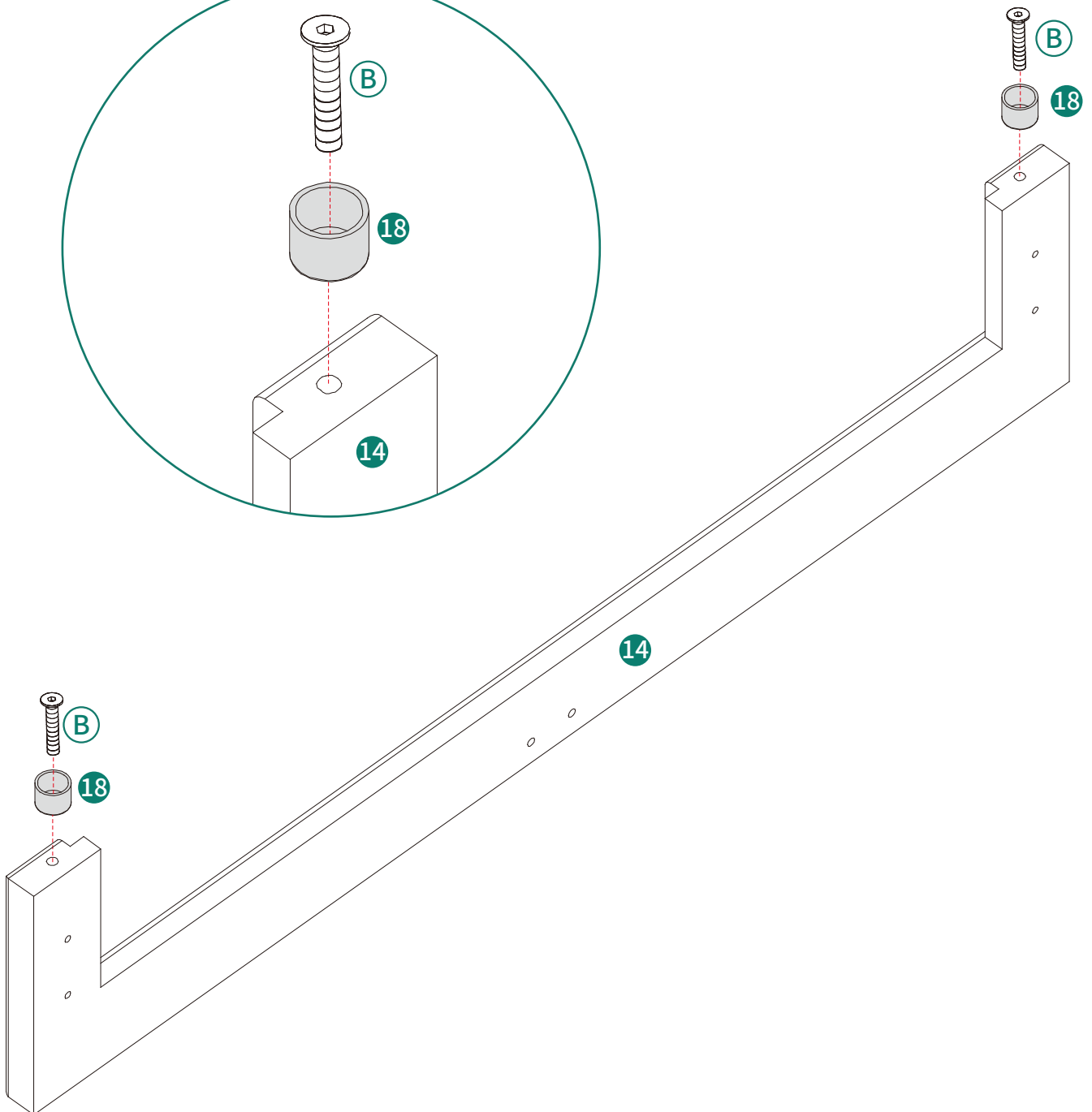
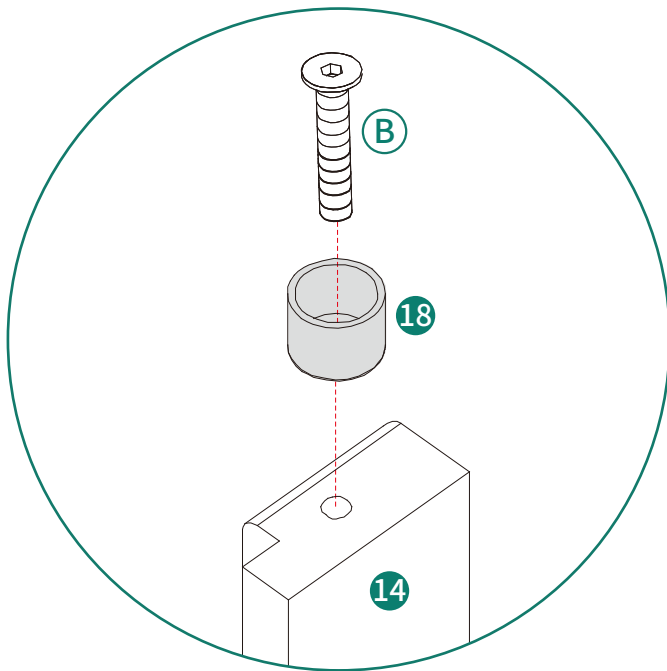

# 18



M8 X 15mm

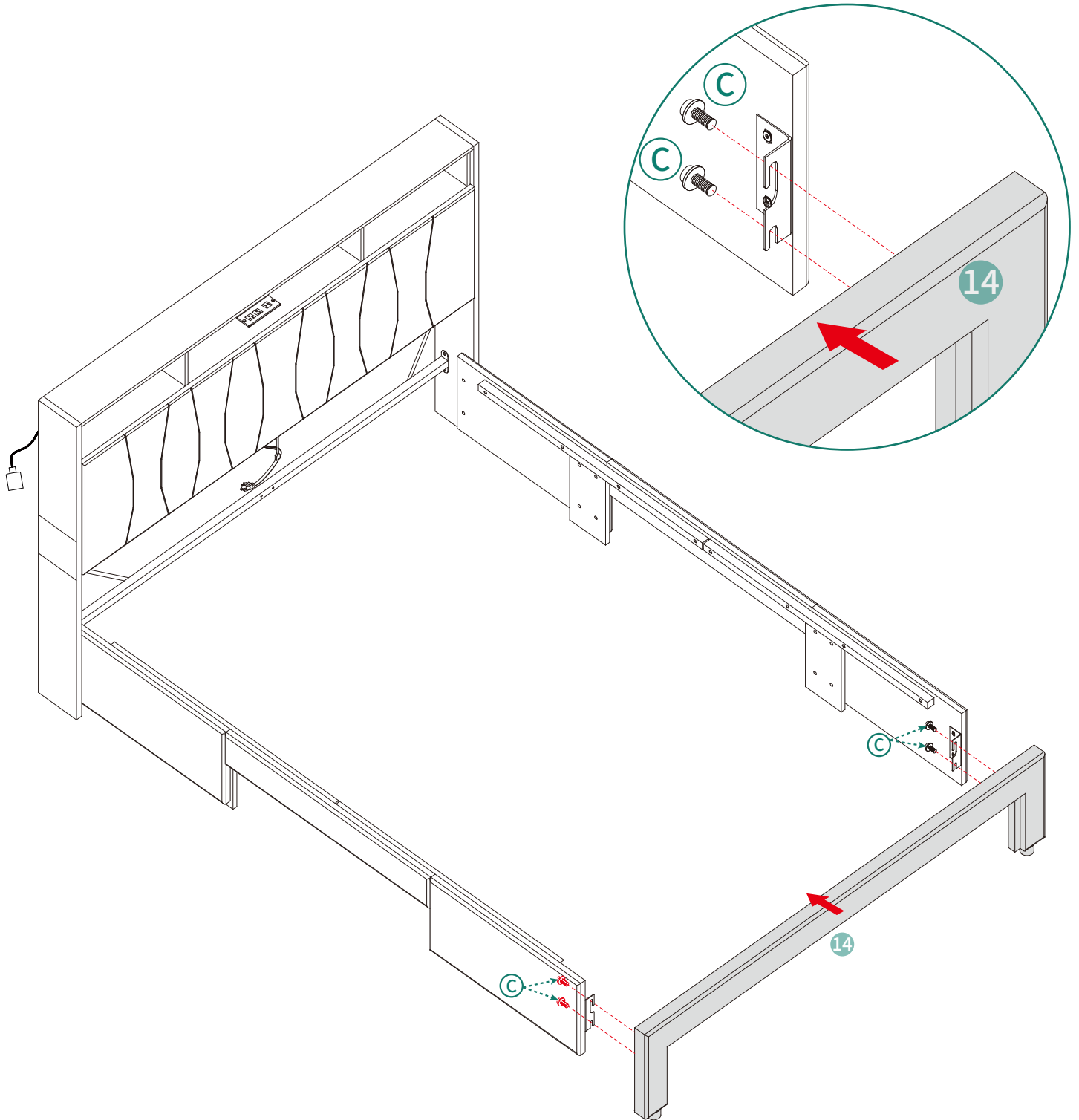
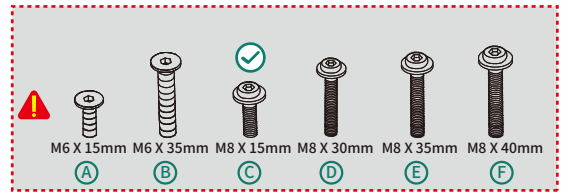

Ⓒ4pcs

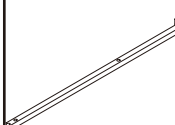
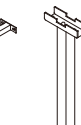
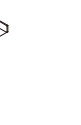

# 19

-  ②1 2pcs
  -  ②2 1pc
  -  ②3 2pcs
  -  ②E 4pcs
- M8 X 35mm

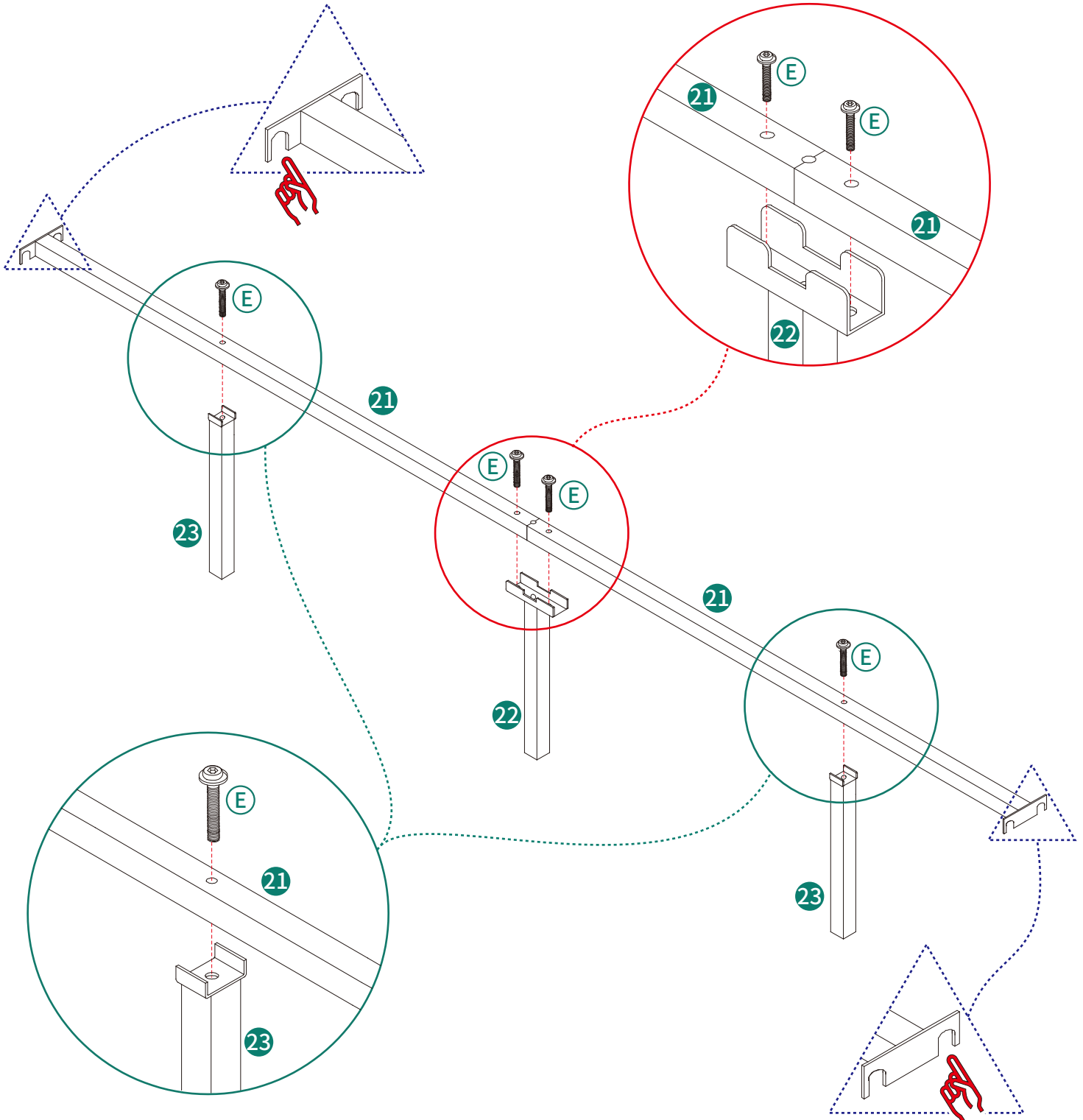
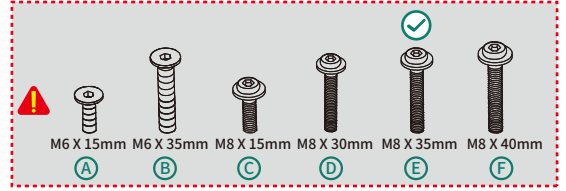

# 20

M8 X 15mm



Ⓒ4pcs

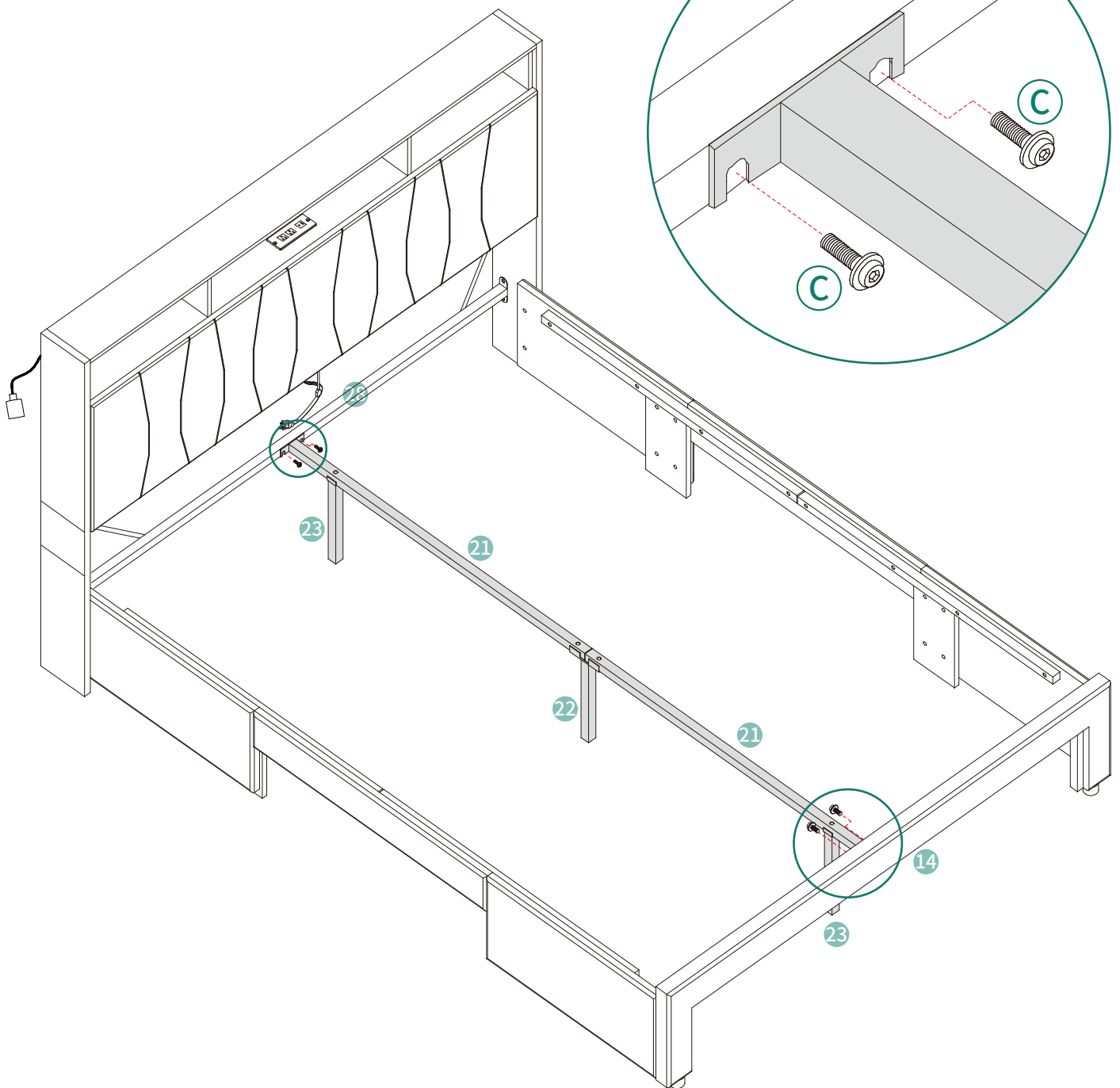
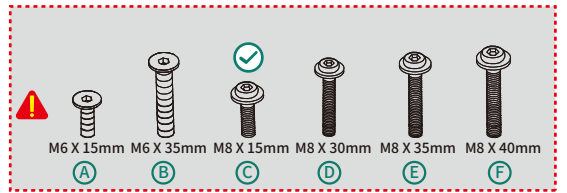

**21**

M8 X 40mm

20 1pc

F 5pcs

M6 X 15mm (A) M6 X 35mm (B) M8 X 15mm (C) M8 X 30mm (D) M8 X 35mm (E) M8 X 40mm (F)

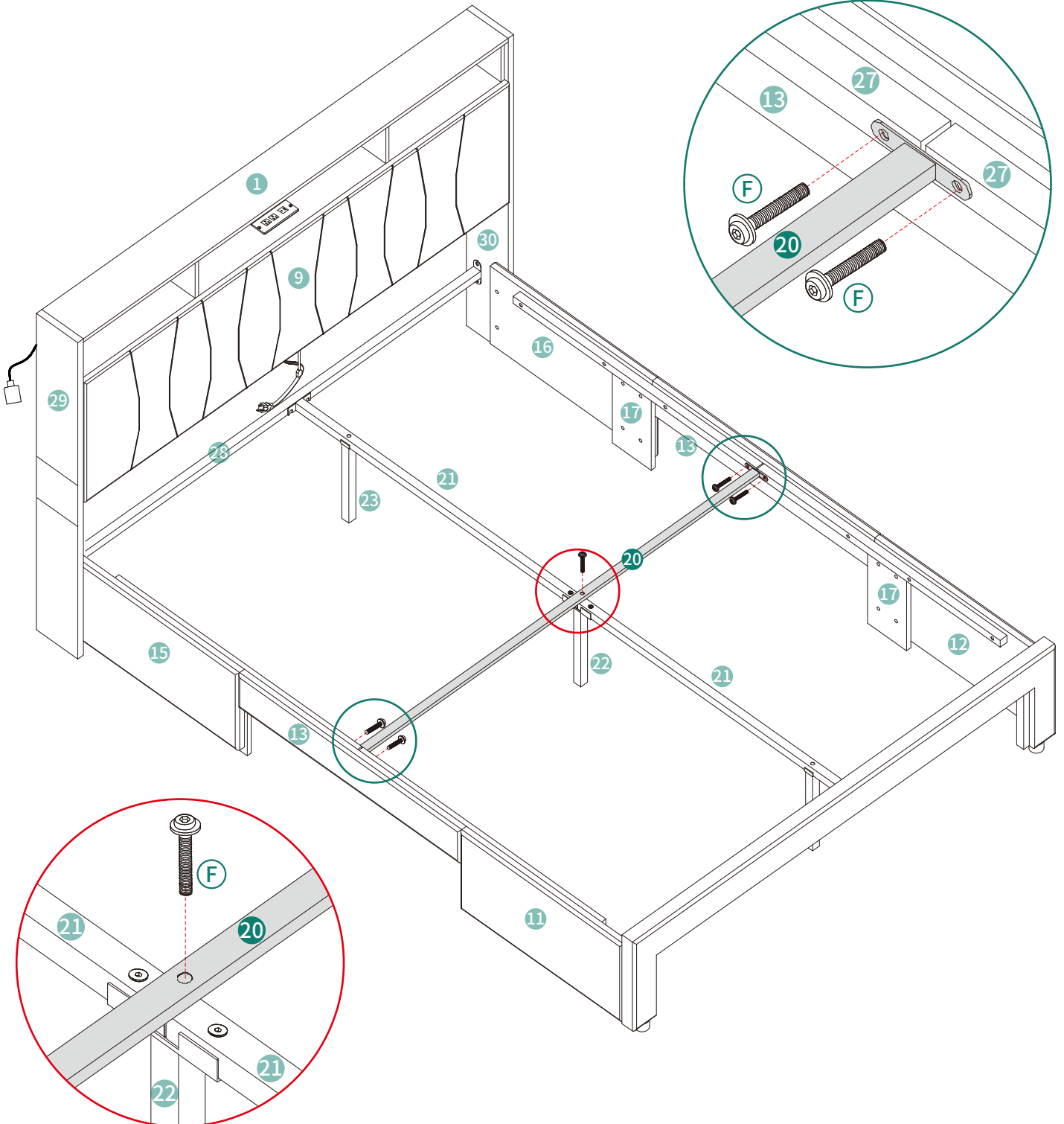

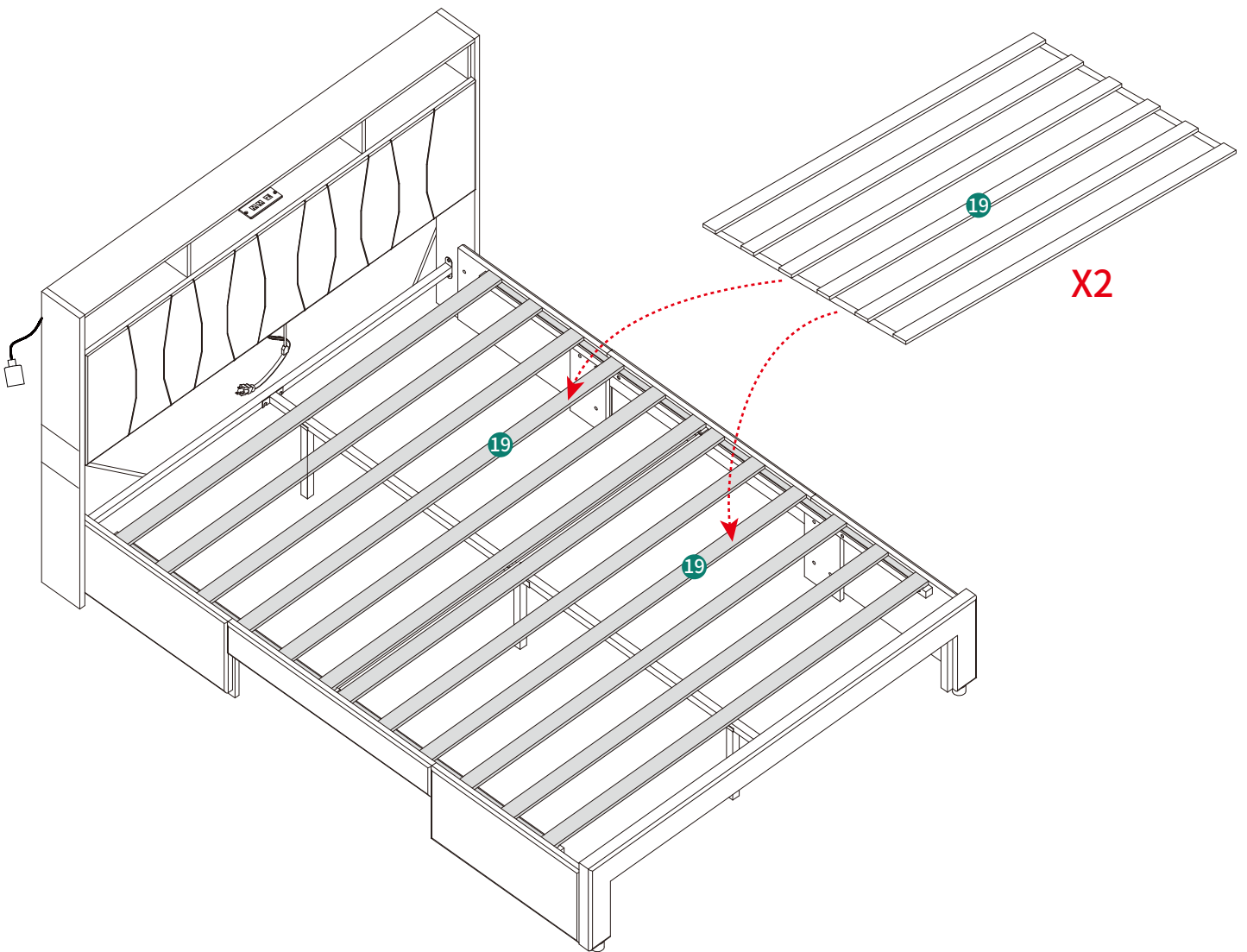
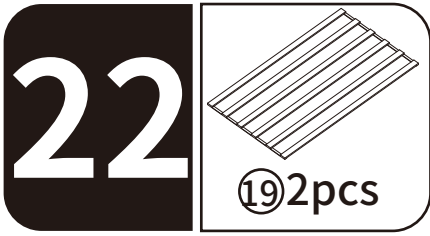

# 23

X2

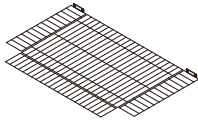

26/41 2pcs



31 8pcs

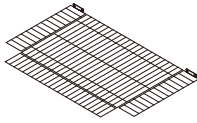

41 2pcs

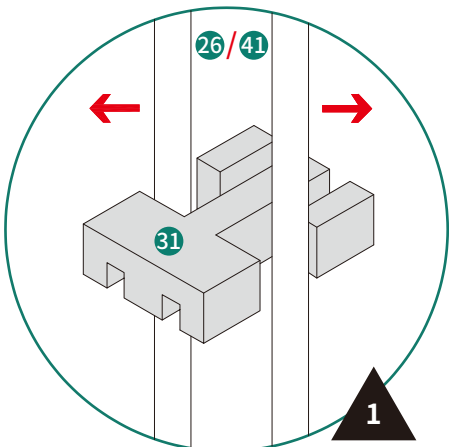
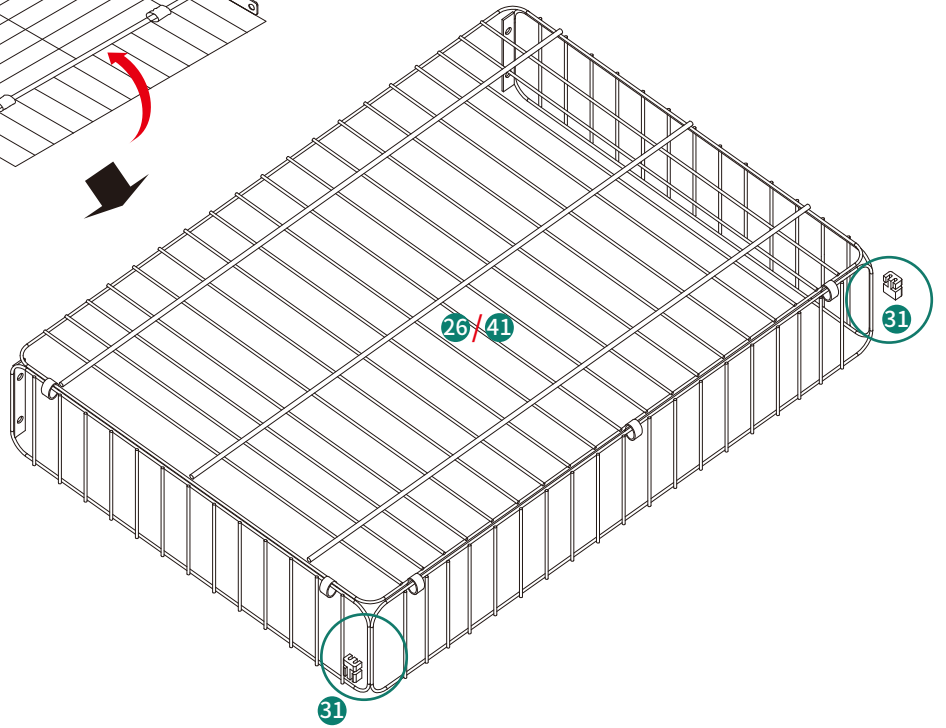
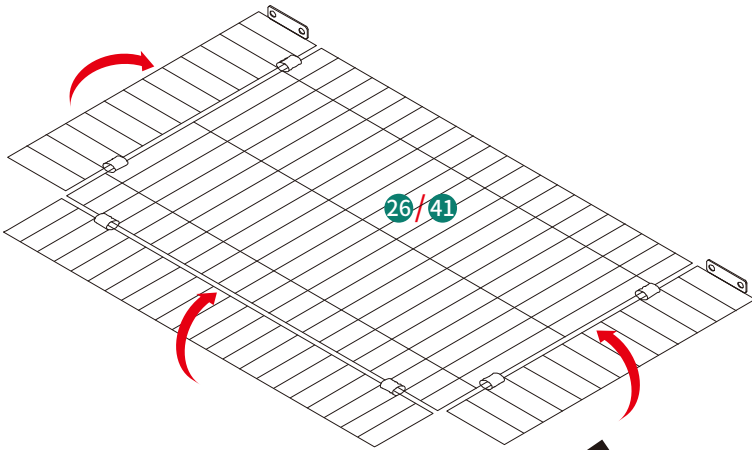

1

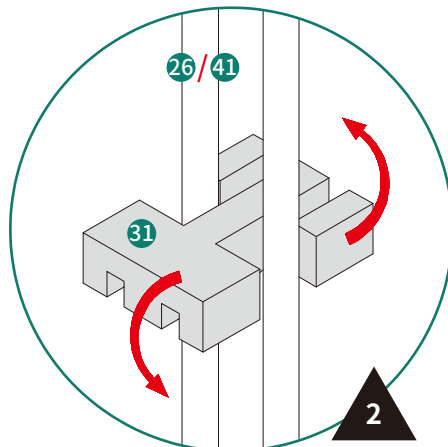

2

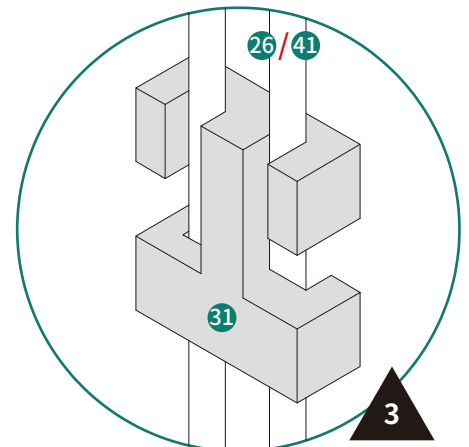

3

**24**

**X4**

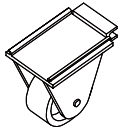

35 16 pcs

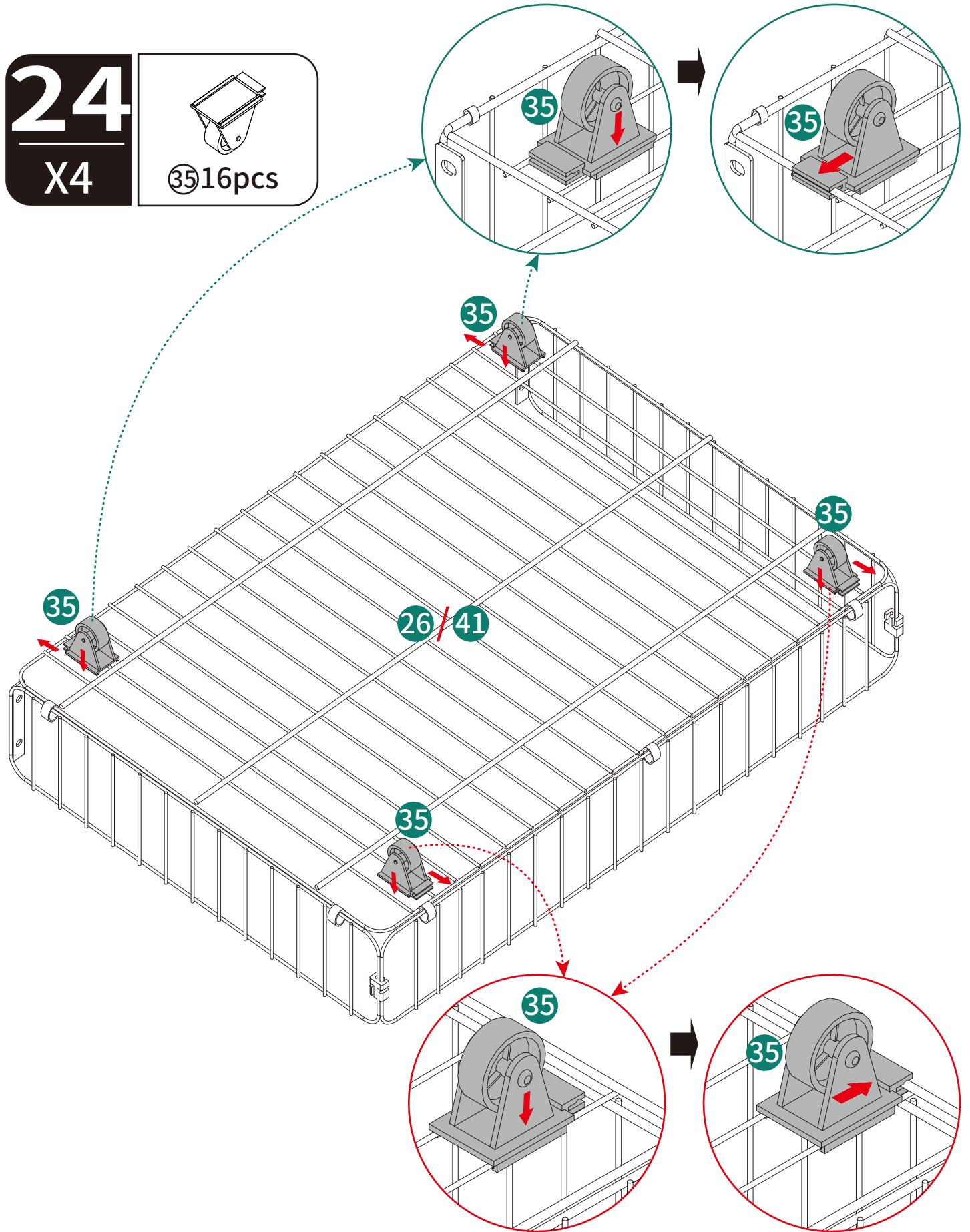

# 25

## X2



32 2pcs

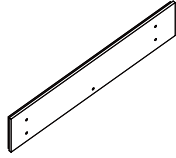

36 2pcs

M6 X 15mm



A 10pcs

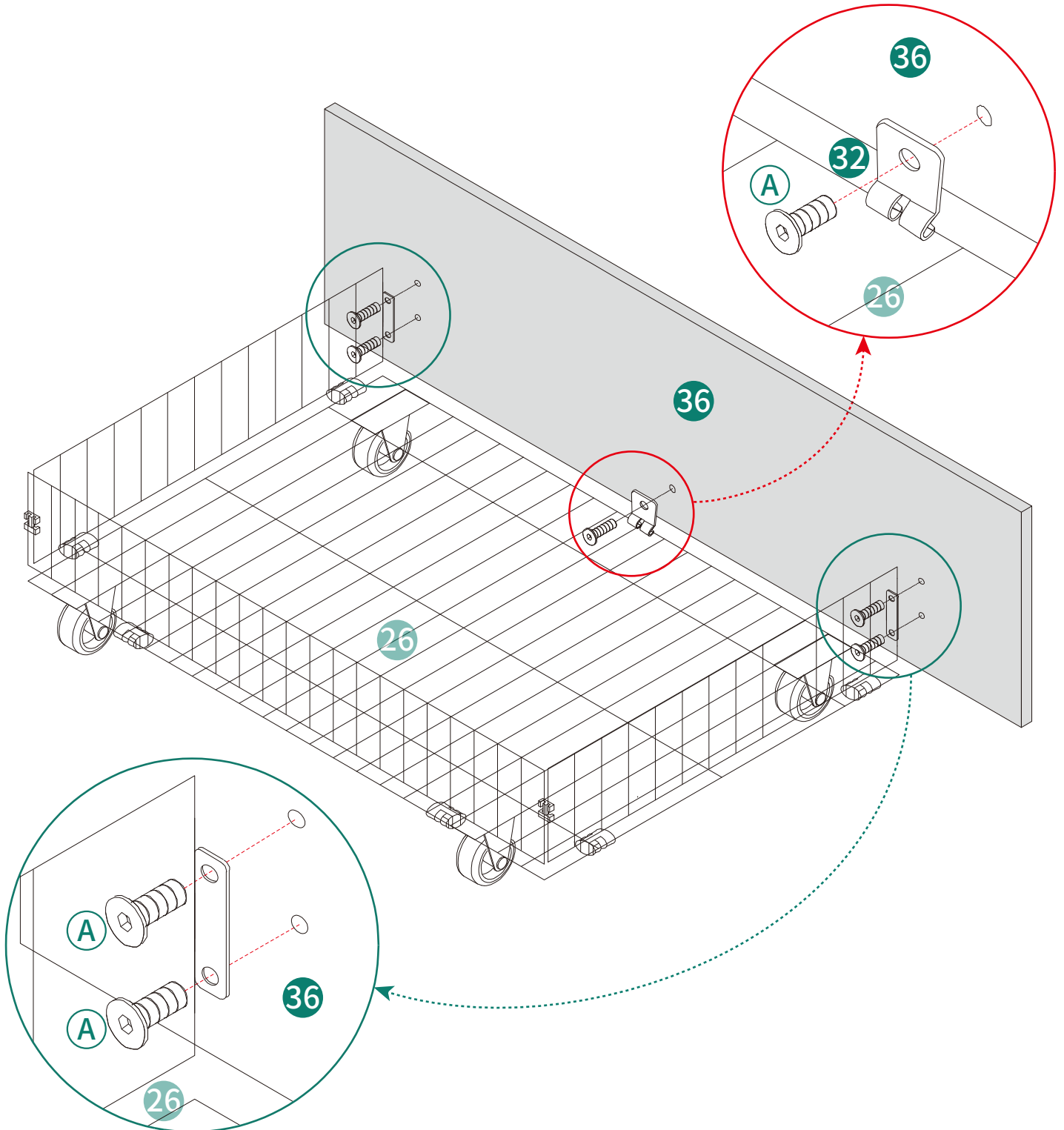
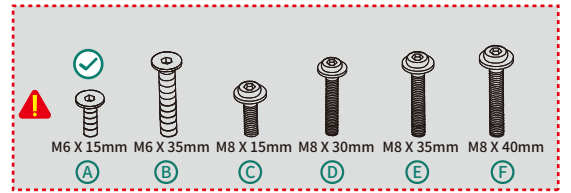

# 26



32 2pcs

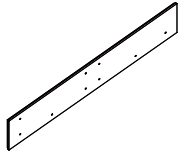

37 1pc

M6 X 15mm



A 10pcs

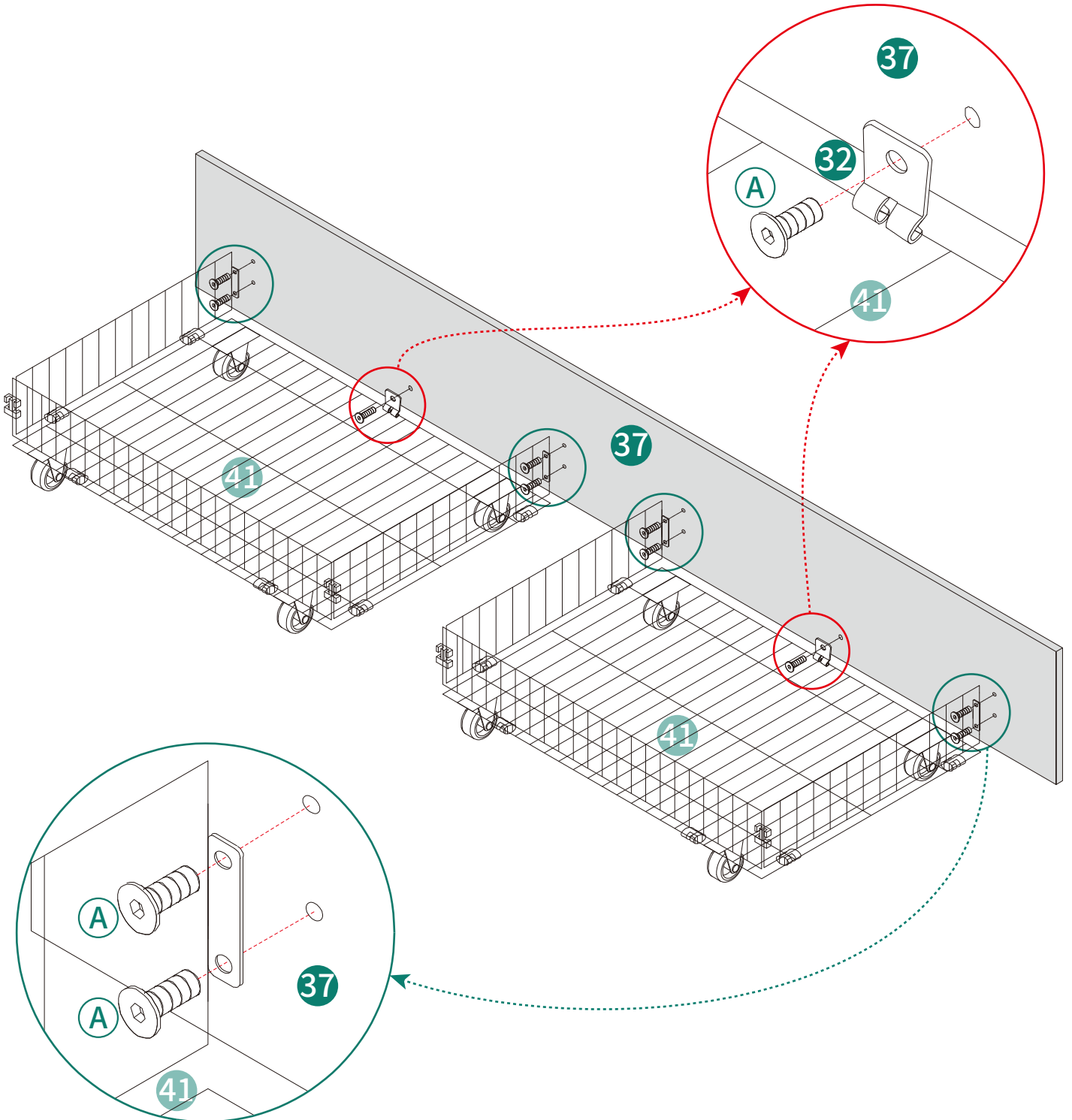
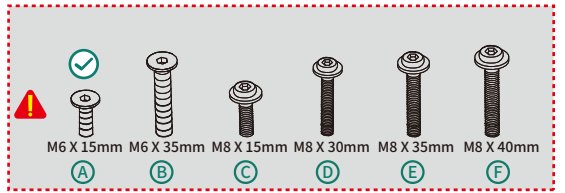

27

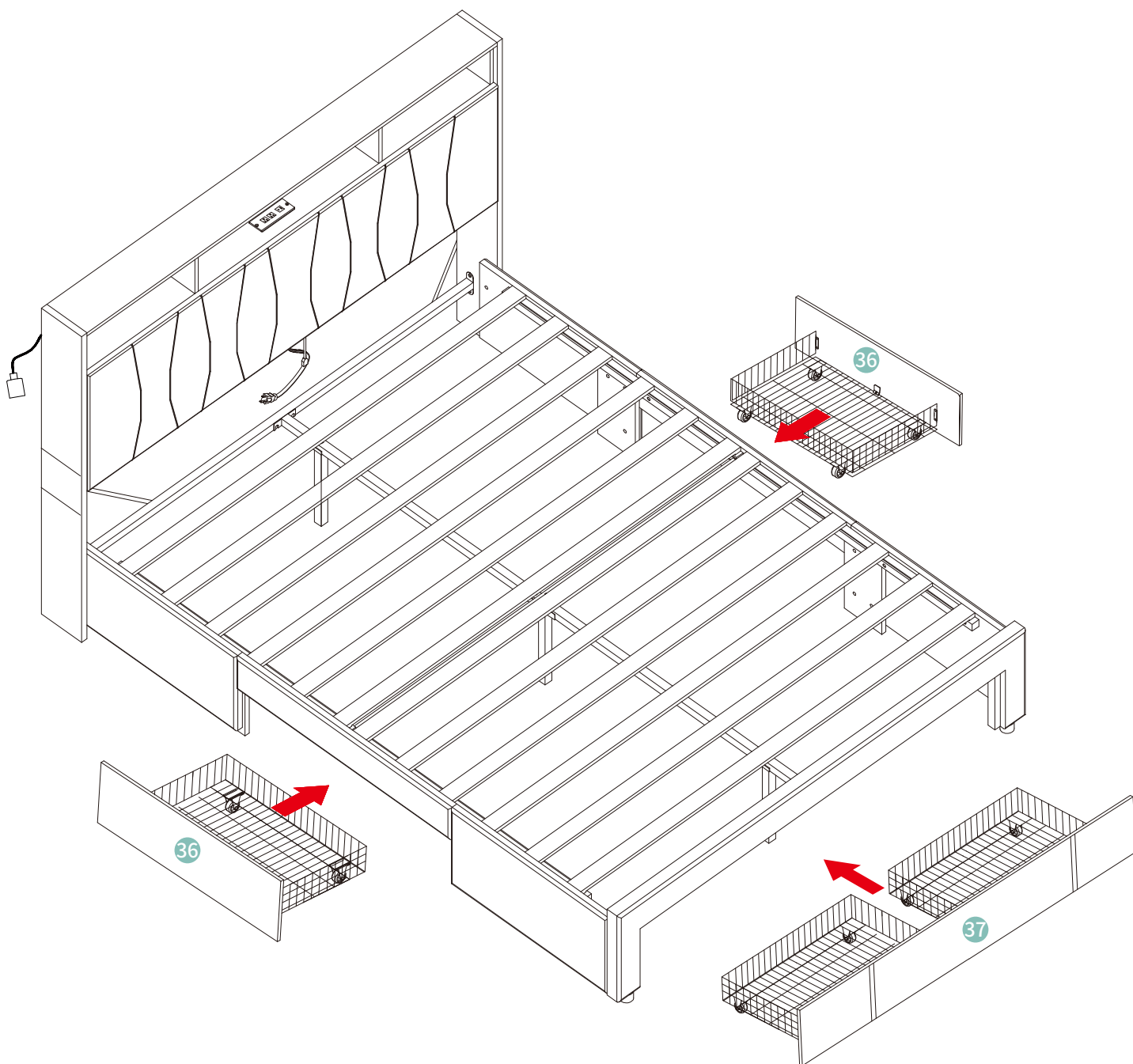

28

33 1pc

Hook-and-loop fastener  
Klettverschluss  
Velcro  
Velcro  
Velcro

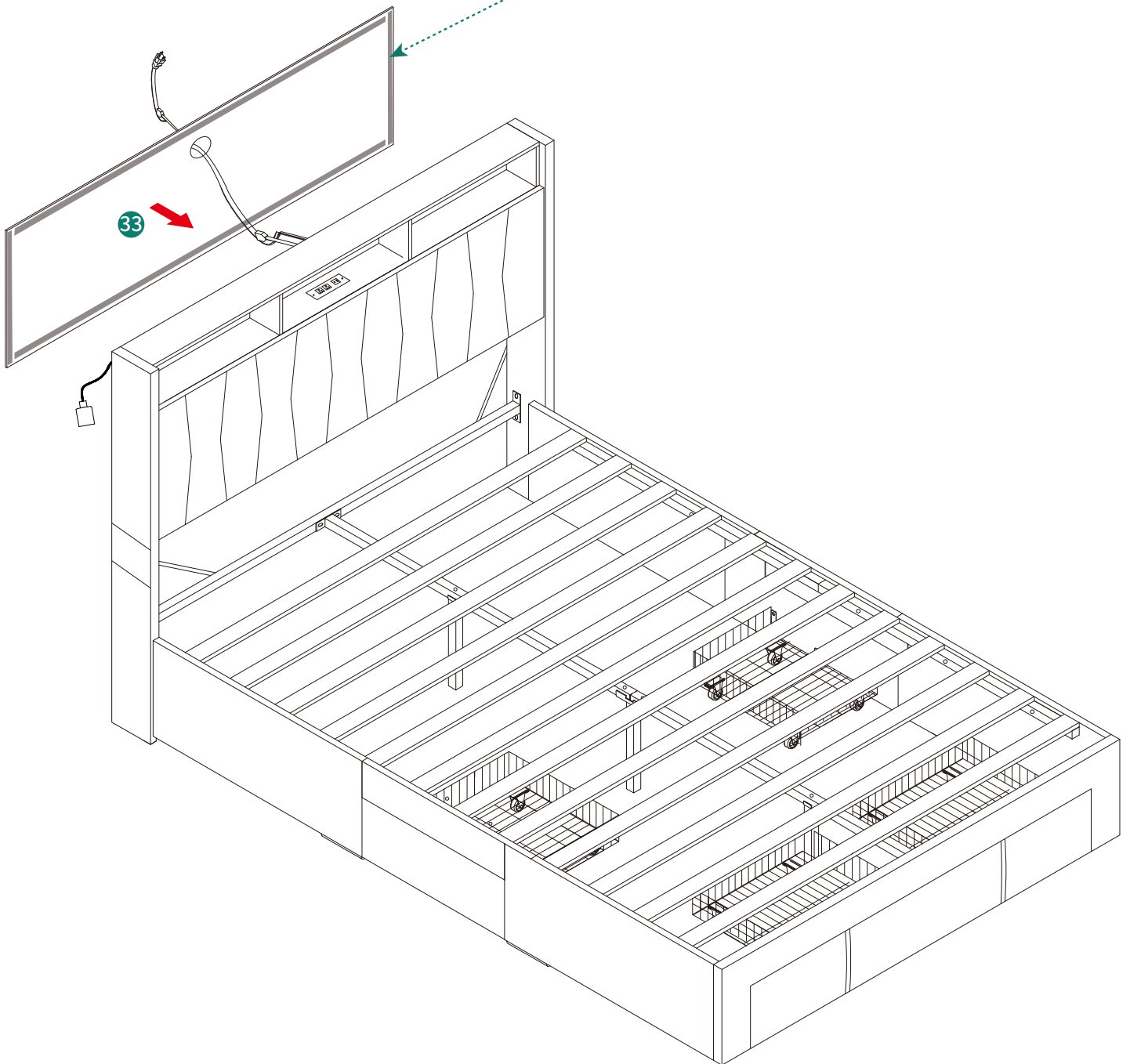

# 29

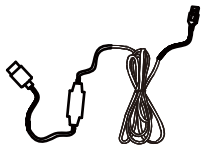

34-2 1pc

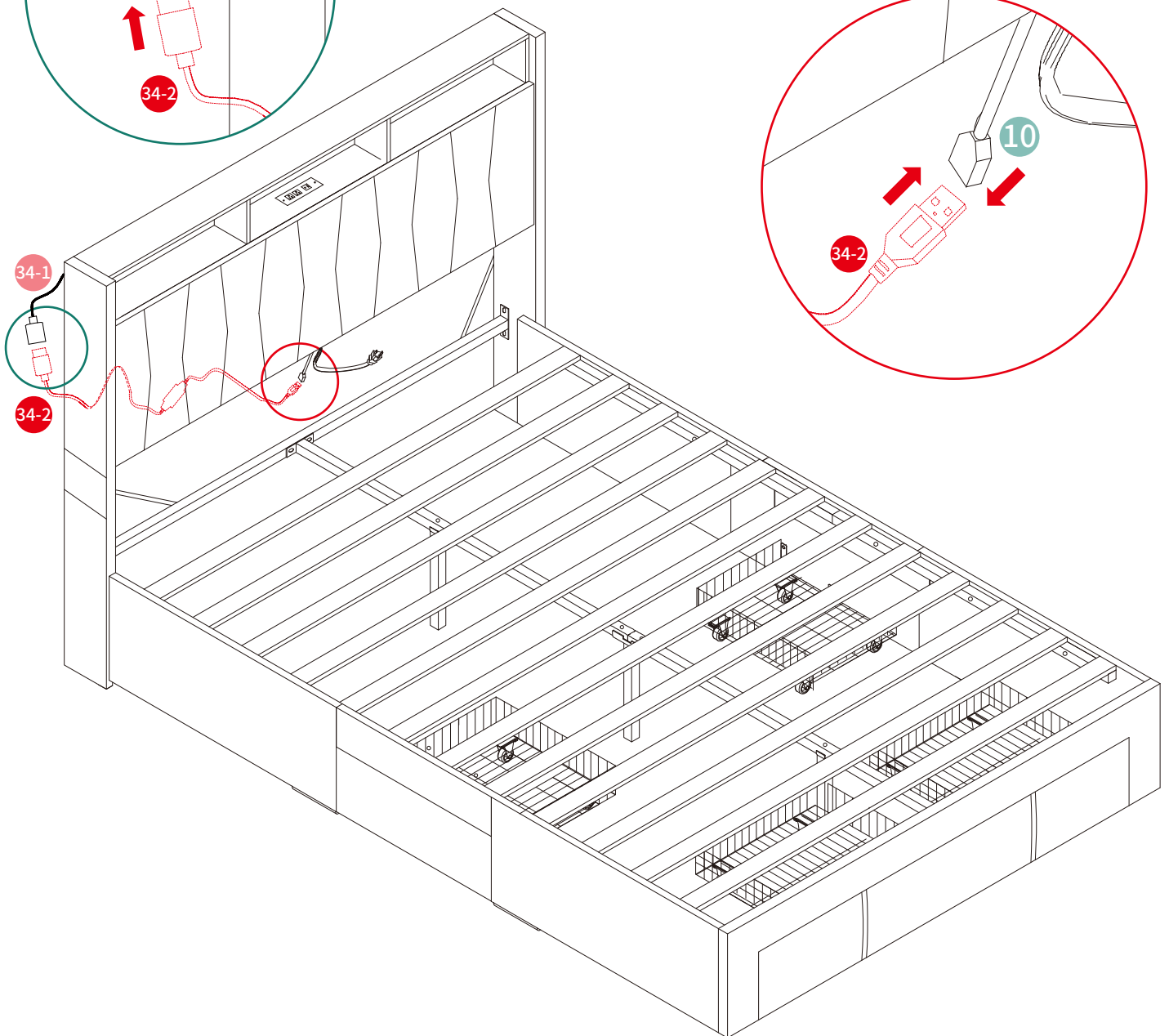
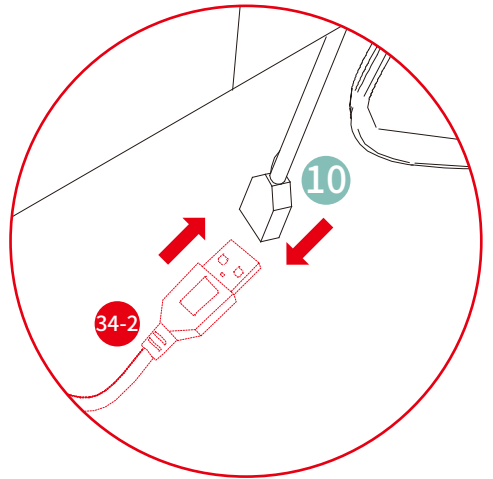
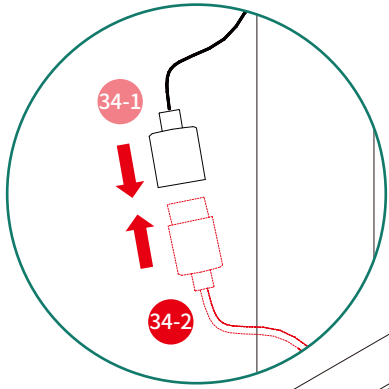



Not included  
Nicht enthalten  
Non inclus  
Non incluso  
No incluido

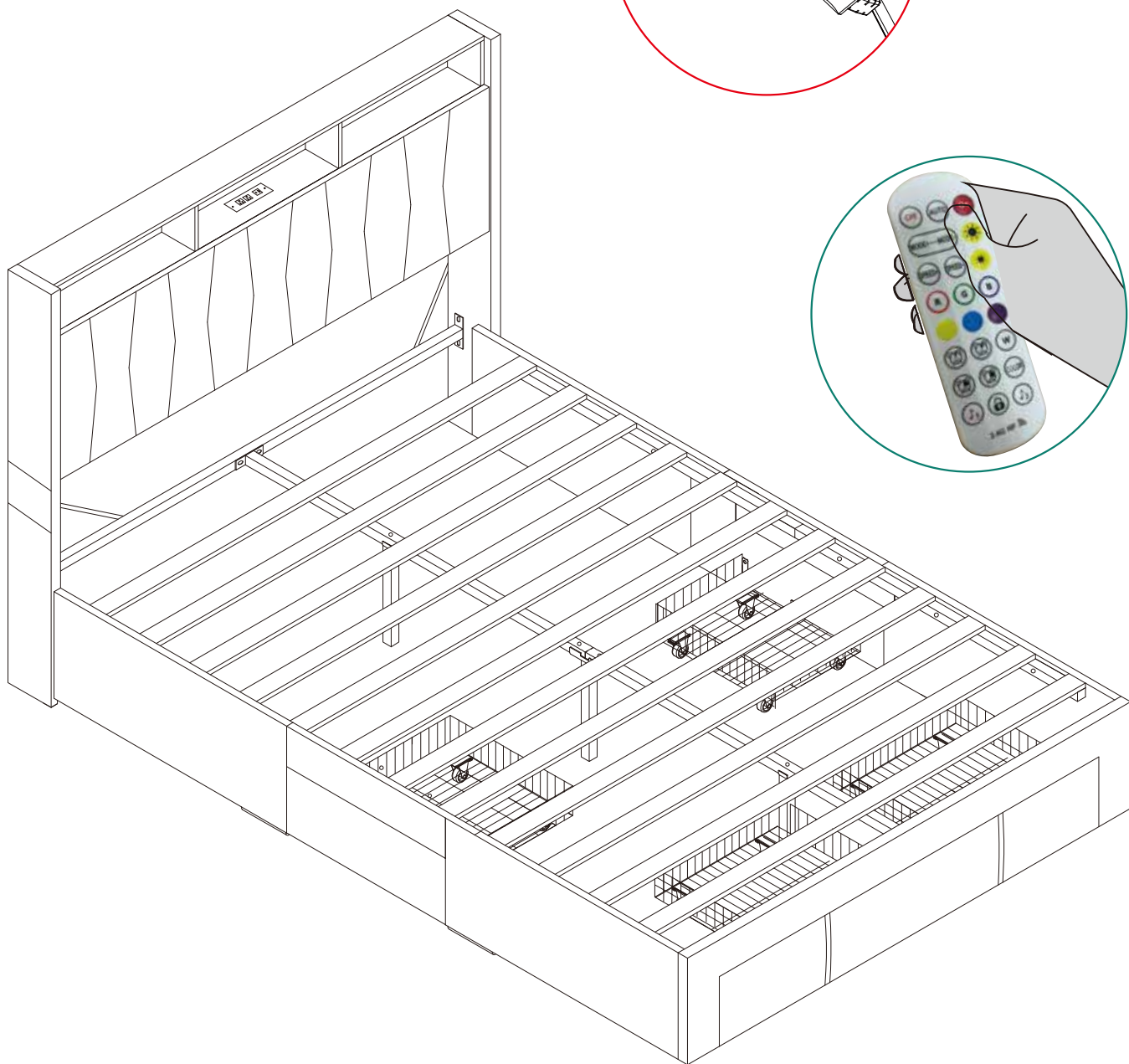
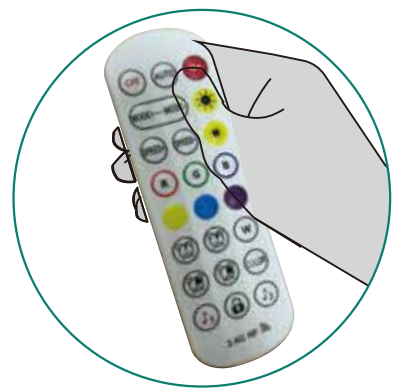
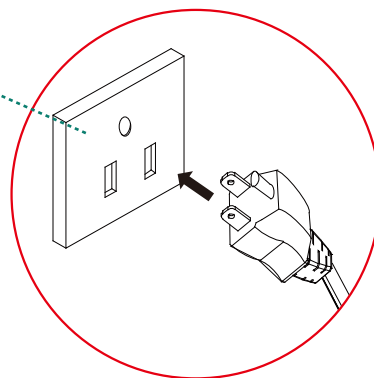

# 31

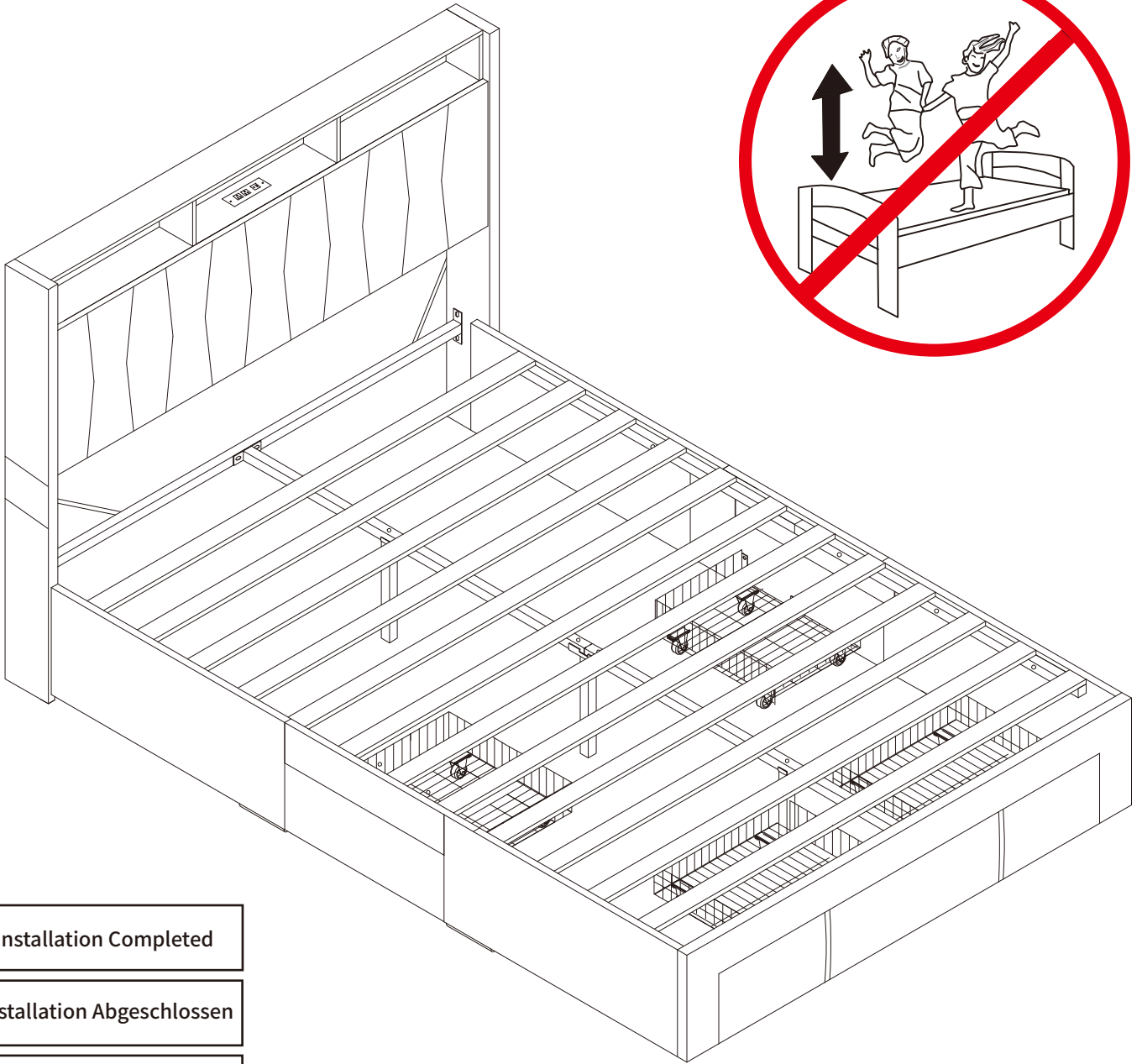

Installation Completed

Installation Abgeschlossen

Installation Complétée

Installazione Completata

Instalación Completada

# HELP CENTER



Inquiry



Assembly issue



Missing parts

If you encounter any difficulties during assembly, please contact us.  
Wenn Sie während der Montage auf Schwierigkeiten stoßen, kontaktieren Sie uns bitte.  
Si vous rencontrez des difficultés lors du montage, veuillez nous contacter.  
Se incontri difficoltà durante il montaggio, ti preghiamo di contattarci.  
Si encuentras alguna dificultad durante el ensamblaje, por favor contáctanos.

# DISCLAIMER

Manufacturer and seller expressly disclaim any and all liability for personal injury, property damage or loss, whether direct, indirect, or incidental, resulting from the incorrect attachment, improper use, inadequate maintenance, unapproved modification, or neglect of this product.

Der Hersteller und Verkäufer lehnen ausdrücklich jegliche Haftung für Personenschäden, Sachschäden oder Verluste ab, egal ob direkt, indirekt oder zufällig, die durch falsche Anbringung, unsachgemäßen Gebrauch, unzureichende Wartung, nicht genehmigte Änderungen oder Vernachlässigung dieses Produkts entstehen.

El fabricante y vendedor renuncian expresamente a toda responsabilidad por lesiones personales, daños materiales o pérdidas, ya sean directos, indirectos o incidentales, derivados de la incorrecta colocación, uso inadecuado, mantenimiento insuficiente, modificación no aprobada o negligencia de este producto.

Il produttore e il venditore declinano espressamente ogni responsabilità per lesioni personali, danni materiali o perdite, dirette, indirette o incidentali, derivanti dall'errato fissaggio, uso improprio, manutenzione inadeguata, modifica non autorizzata o negligenza di questo prodotto.

Le fabricant et le vendeur déclinent expressément toute responsabilité en cas de blessures corporelles, de dommages matériels ou de pertes, qu'ils soient directs, indirects ou accessoires, résultant de la fixation incorrecte, de l'utilisation inappropriée, de l'entretien insuffisant, de la modification non approuvée ou de la négligence de ce produit.