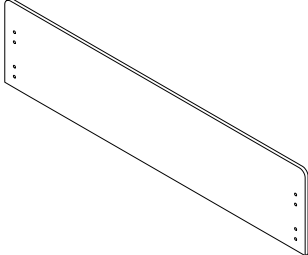
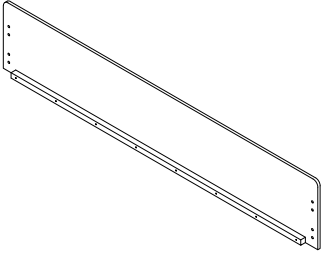
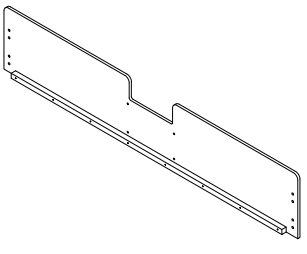
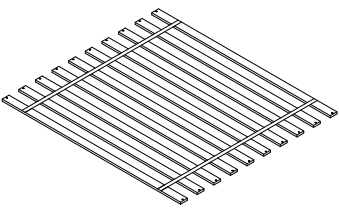
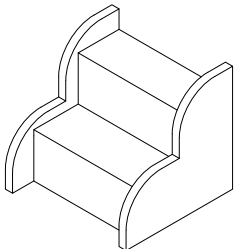

Part List / Liste des pièces

Label/ Étiquette	Picture/ Image	Description	QTY/ Quantité
A		HEADBOARD AND FOOTBOARD / TÊTE DE LIT ET PIED DE LIT	2
B		SIDE PANEL INSIDE/ PANNEAU LATÉRAL À L'INTÉRIEUR	1
C		SIDE PANEL OUTSIDE / PANNEAU LATÉRAL EXTÉRIEUR	1
D		SLAT / LAME	1SET/ 10pcs

Part List / Liste des pièces

Label/ Étiquette	Picture/ Image	Description	QTY/ Quantité
E		STAIR / ESCALIER	1

Hardware

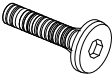
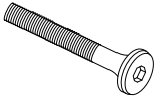
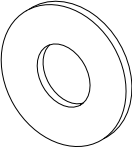
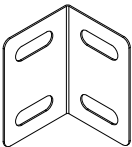
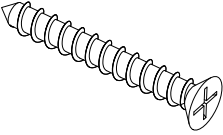
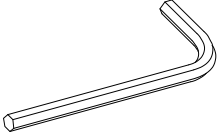
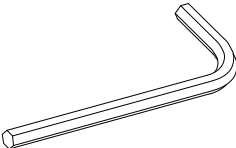
Label/ Étiquette	Picture/ Image	Description	QTY/ Quantité
①		JCBB M8 x 16mm	32
②		JCBC M6 x 35mm	4
③		Flat Washer M6 / Rondelle Plate M6	4
④		BED BRACKET / SUPPORT DE LIT	8
⑤		CSK SCREW M4 x 30mm / VIS CSK M4x30mm	20
⑥		Allen Key M4 / Clé Allen M4	1
⑦		Allen Key M5 / Clé allen M5	1

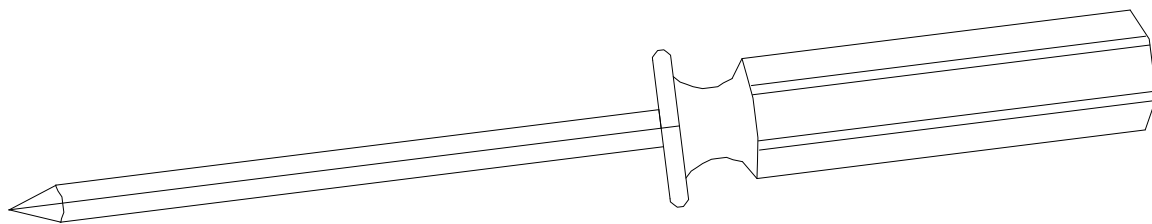

Assembly Tools
Required (Not Included)

Assembly Preparation / Préparation de l'assemblage

Before
Beginning
Assembly

/

Avant de
commencer
l'assemblage

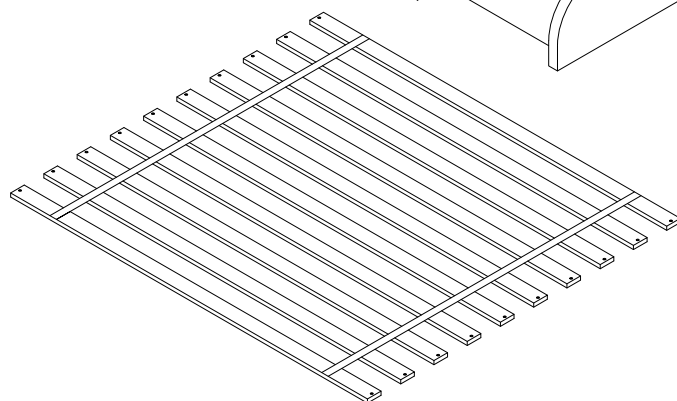
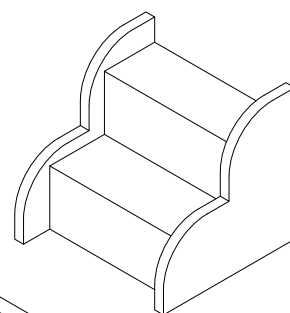
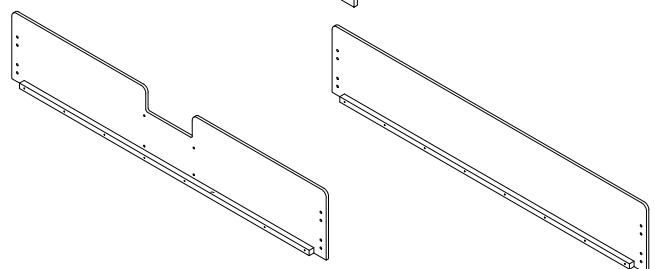
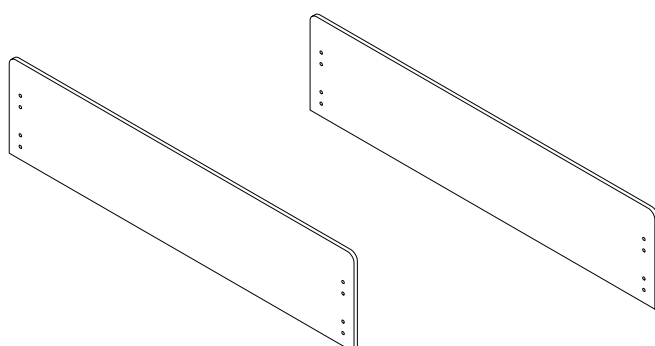
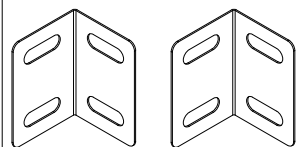
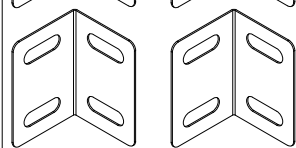
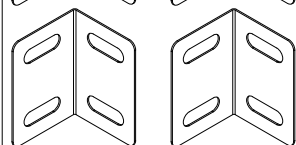
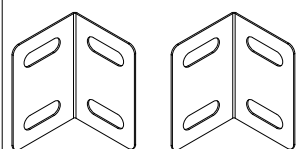
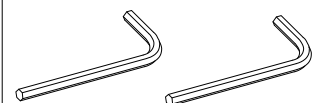
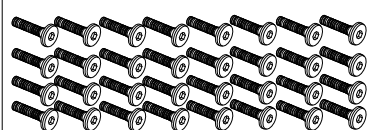

- Read instructions, cover to cover-



- Have 2 adults on hand for assembly-



- Do not assemble on flooring or carpet-



- Assemble on a clean non-marring surface (packing foam)-



- Save all packaging until finished-



- Lire les instructions, de bout en bout



- Avoir 2 adultes à portée de main pour l'assemblage



- Ne pas assembler sur un sol ou un tapis



- Assembler sur une surface propre ne marquant pas (mousse d'emballage)



- Conservez tous les emballages jusqu'à la fin

Assembly Step / Étape d'assemblage

Overview

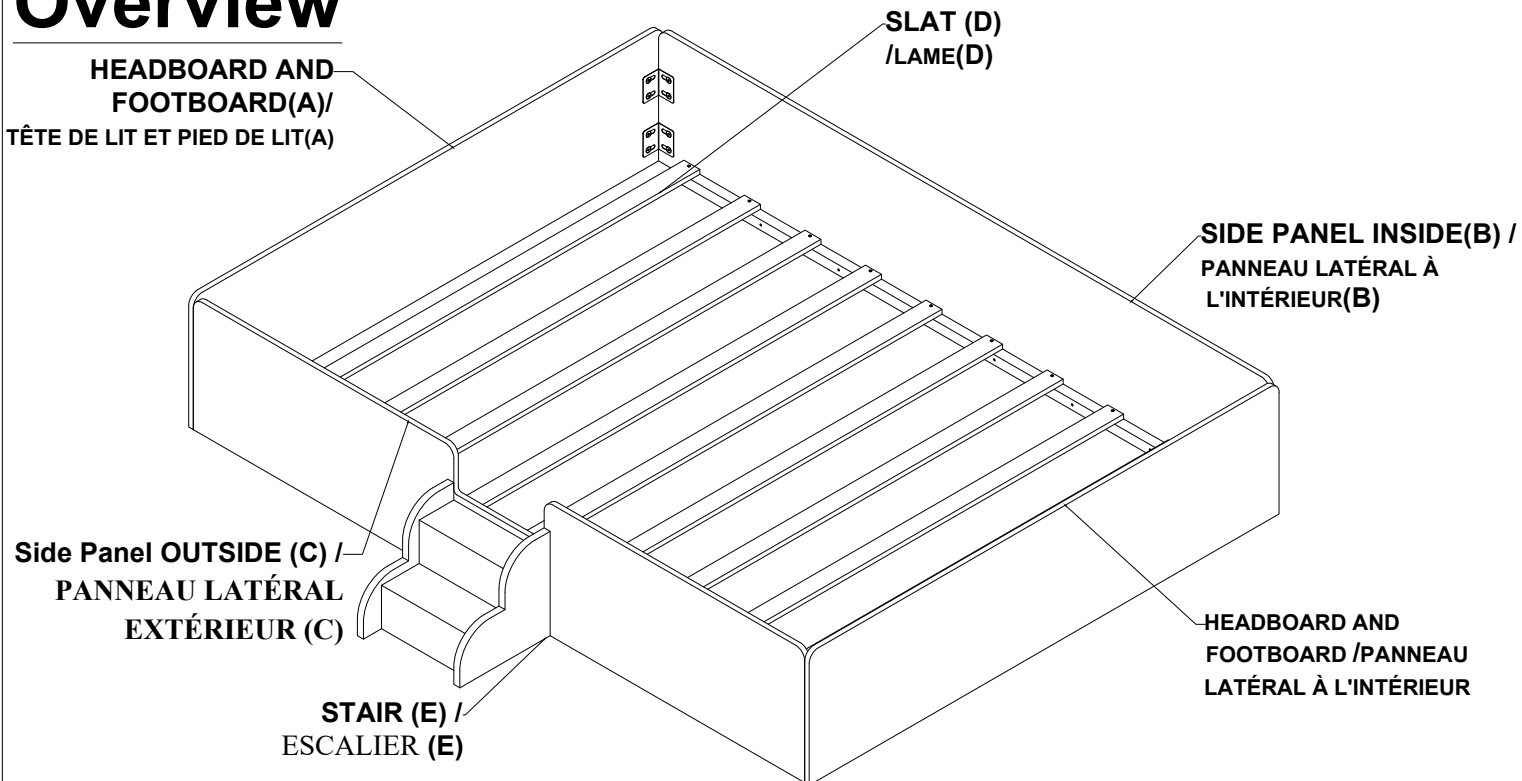

Step 1

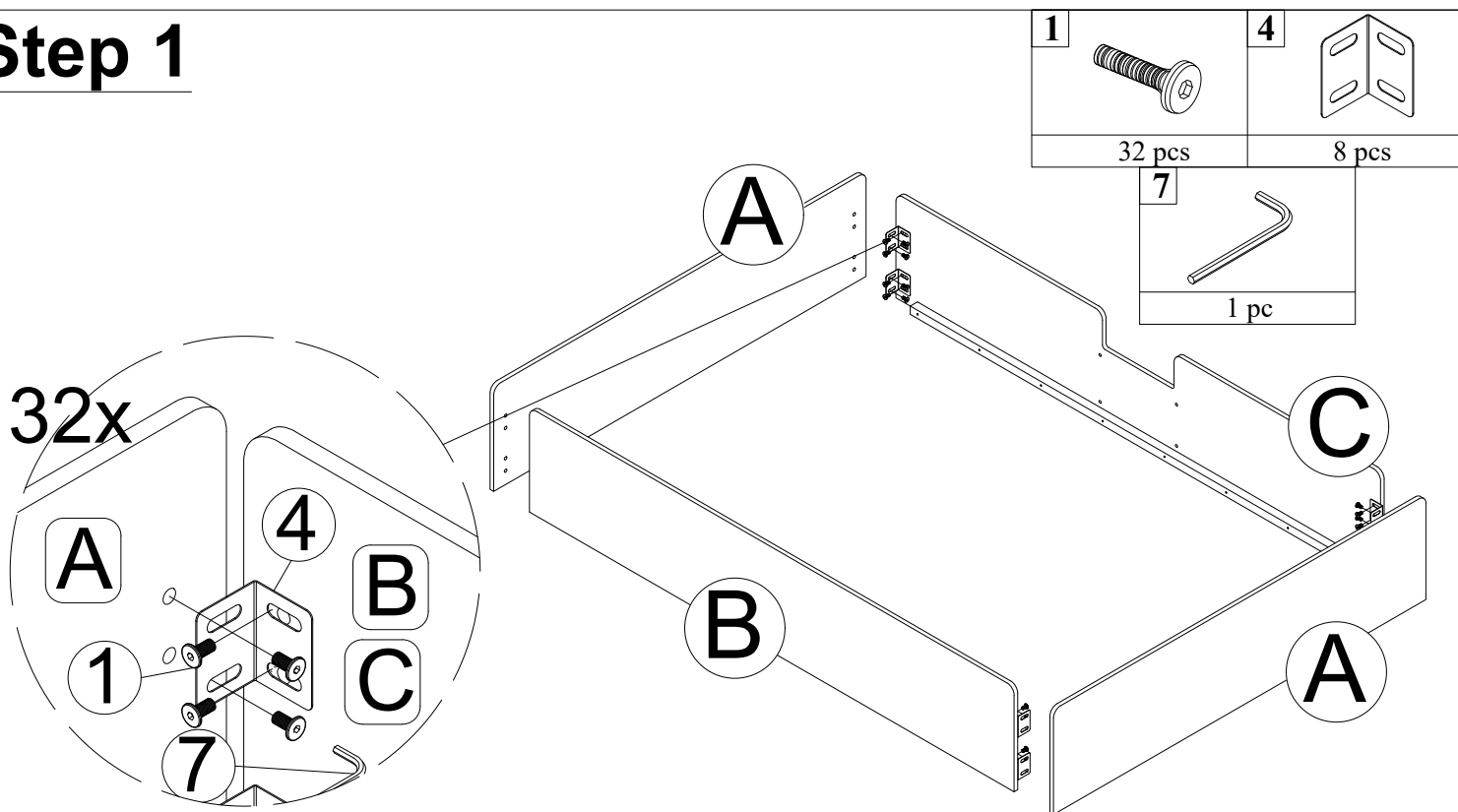

Connect the Headboard (A) to the Side Panel Inside(B) and Side Panel Outside(C) by placing JCBB M8 x 16mm (1) 8 pieces and bed bracket (4) 2 pieces on every corner and tie up by using the Allen Key (7).
***Tighten by turning the JCBB M8 x 16mm (1) by Allen Key M5 (7) clockwise.**

Connectez la tête de lit (A) au panneau latéral intérieur (B) et au panneau latéral extérieur (C) en plaçant 8 pièces JCBB M8 x 16 mm (1) et le support de lit (4) 2 pièces à chaque coin et attachez-les à l'aide du tournevis Allen. Clé (7).
***Serrez en tournant le JCBB M8 x 16 mm (1) à l'aide de la clé Allen M5 (7) dans le sens des aiguilles d'une montre.**

Assembly Step / Étape d'assemblage

Step 2

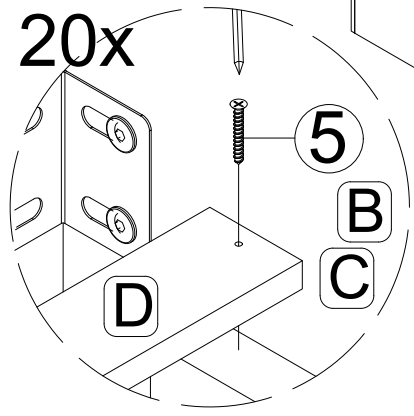
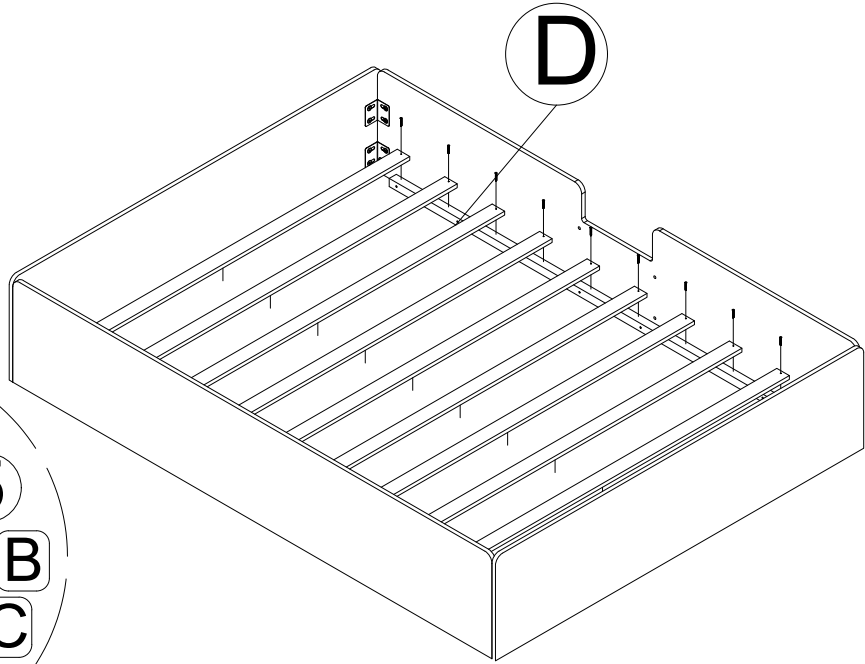
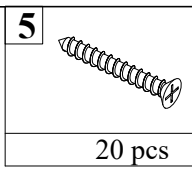

Install the Slat (D) on the base of the side wood already attached to the Inside Panel (B) and Outside Panel (D).
 *Slat position (D) can be fixed by using CSK M4 x 30mm Screws (5) 20 (TWENTY) pieces, each slat(D) uses 2 (TWO)2 pieces.

Installez la latte (D) sur la base du bois latéral déjà fixé au panneau intérieur (B) et au panneau extérieur (D).
 *La position des lattes (D) peut être fixée à l'aide de vis CSK M4 x 30 mm (5) 20 (VINGT) pièces, chaque latte(D) utilise 2 (DEUX)2 pièces.

Step 3

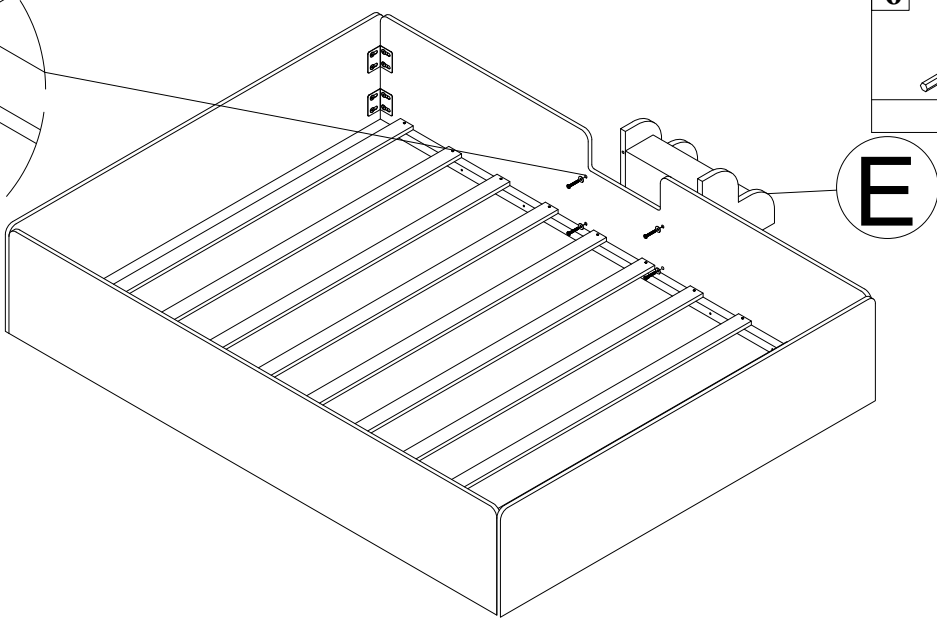
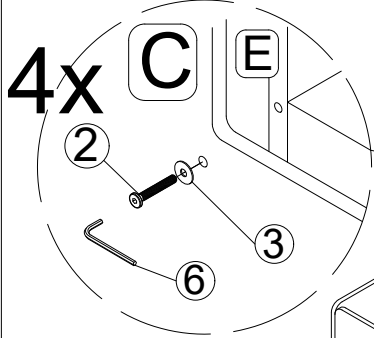
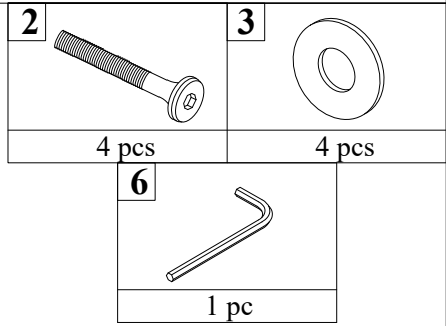

Attach the Stair(E) to the Side Panel Outside (C).
 The Stair position can be set using JCBC M6x30mm(2)4 pieces and flat washer M6(3)4 pieces.
 *Tighten by turning JCBC M6 x 30mm(2) using ALLEN KEY M4(6).

Fixez l'escalier (E) au panneau latéral extérieur (C).
 La position de l'escalier peut être réglée à l'aide de JCBC M6x30mm(2)4 pièces et rondelle plate M6(3)4 pièces.
 *Serrez en tournant JCBC M6 x 30mm(2) à l'aide de la CLÉ ALLEN M4(6).

Step 4

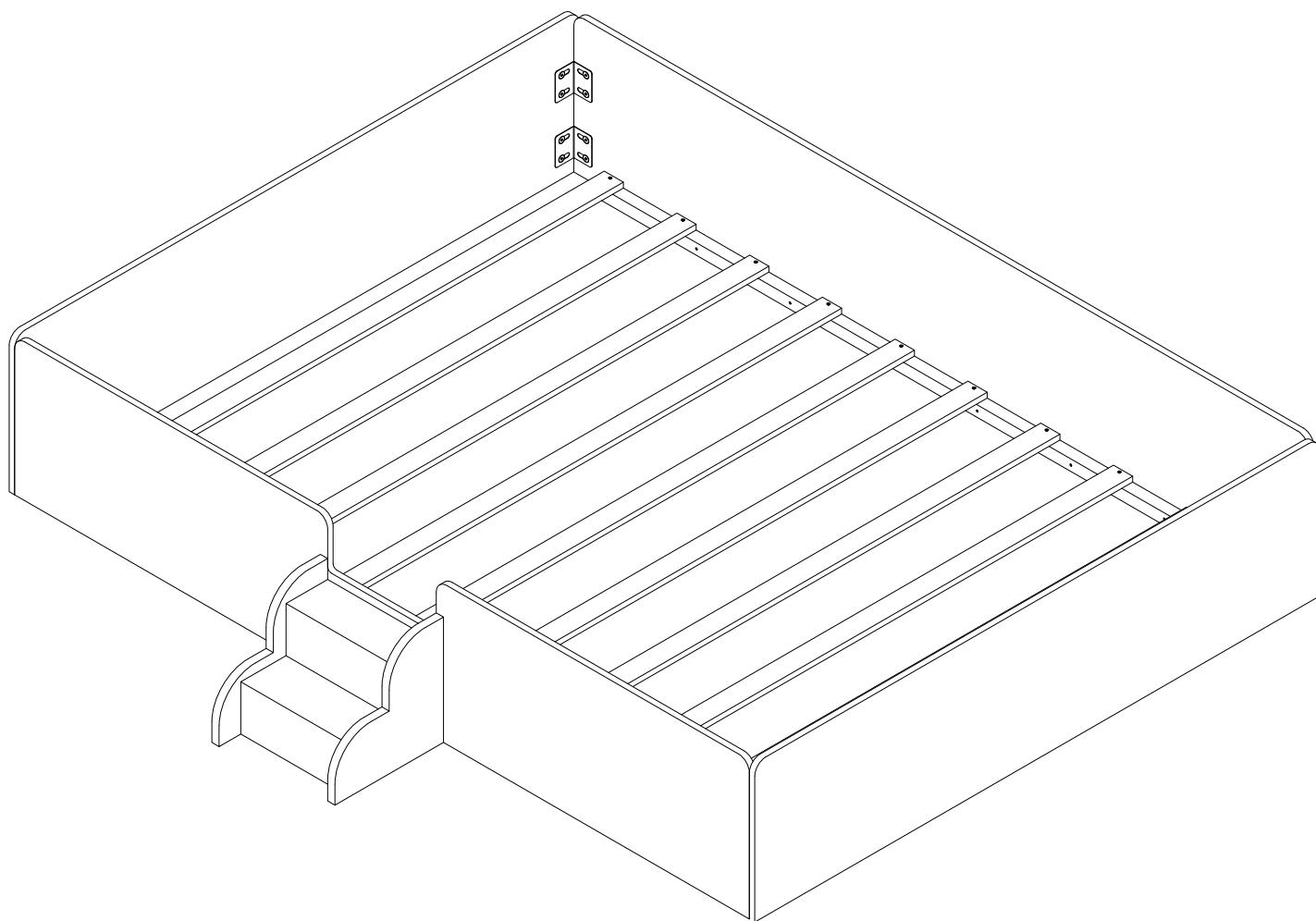

FULLY COMPLETED ASSEMBLY /
ASSEMBLAGE ENTIÈREMENT COMPLÉTÉ