

GW-DO-24" - 30"

Shower Enclosure Installation Guide

Albedo Door Only
Shower Enclosure



Read all Instructions Prior to Installation.
Professional Installation Required.

GLASSWAREHOUSE

Important Safety Information



WARNING!

Professional Installation Only

- Installation of Glass Products (I.E., Shower and Tub Doors/Enclosures) should be done only by a licensed, experienced contractor
- Installation by an unlicensed or inexperienced installer may result in breakage, damage to property or serious injury.

Risk of Glass Breakage or Shattering

- **DO NOT** use excessive force when opening and closing the shower door or utilizing moving parts.
- Excessive force can result in glass panel shattering with explosive force resulting in serious injury or death. Test all doors and moving parts with care.

Instruct Children in Proper Use.

- Educate children and minors in proper usage of a frameless glass enclosure.
- **DO NOT** allow excessive force, leaning against or hanging from a frameless enclosure. Such actions are inherently dangerous and can result in serious injury or death.

Avoid Contact with Tile Surface During Installation

- Ensure glass panels are placed on rubber blocks or cardboard packing while out of the packaging prior/ during install to protect against breakage.
- Rubber block is provided in hardware pack.
- Wood, cardboard, or other rubber products can also be used.

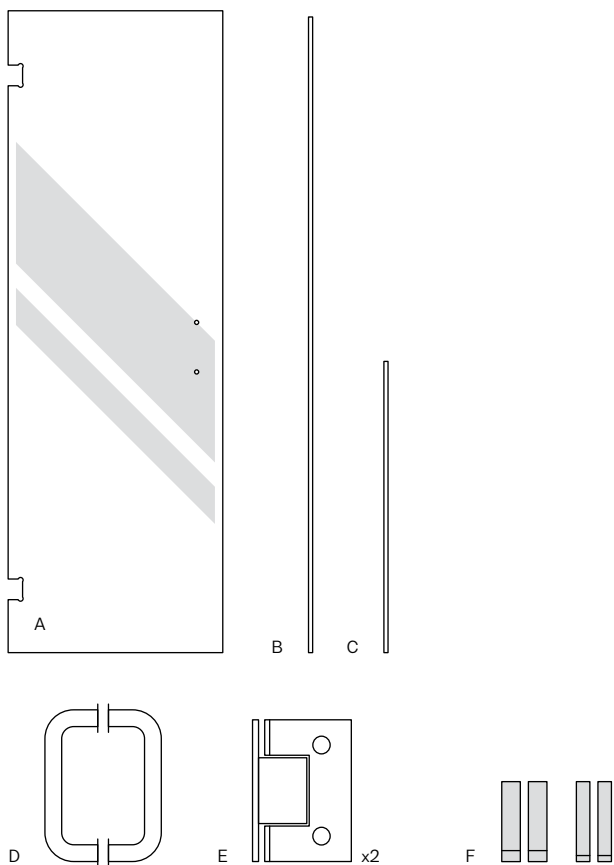

Included in your purchase: Shipped in 3 separate boxes

A Door Panel (GW-D)
B Weather Strip

C Bottom Sweep
D Door Handle

E Wall Hinges
F Rubber Block set (various sizes)

Installation Guide

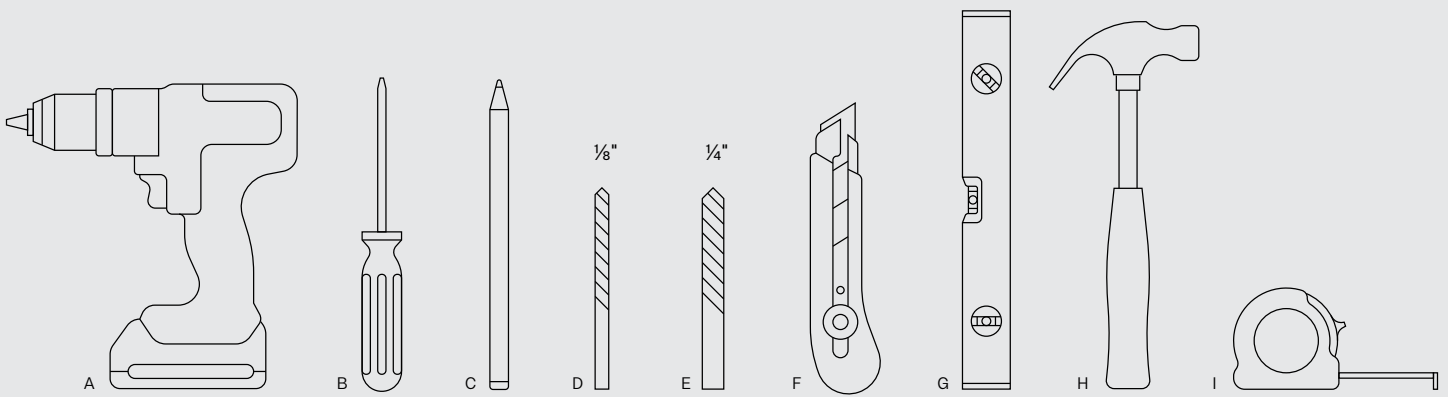

Tools required for install.

A Power drill
B Phillips head screwdriver
C Pencil

D 1/8" tile drill bit
E 1/4" tile drill bit
F Utility knife

G Level
H Hammer
I Tape measure

WARNING

For Fiberglass Walls: When installing on fiberglass walls, ensure a stud is directly behind the panel mounting location. Failure to do so may result in structural instability, damage to the enclosure, and/or death or serious injury.

NOTICE

Reversible Installation: This panel is fully reversible and can be installed on right or left hand wall as needed.

Tip: We recommend marking with a pencil for easy removal.



WARNING

Attach Door Handle: Attach the door handle before lifting the glass. Without a secure grip, the panel can slip or fall, causing glass breakage, severe cuts, or death or serious injury.

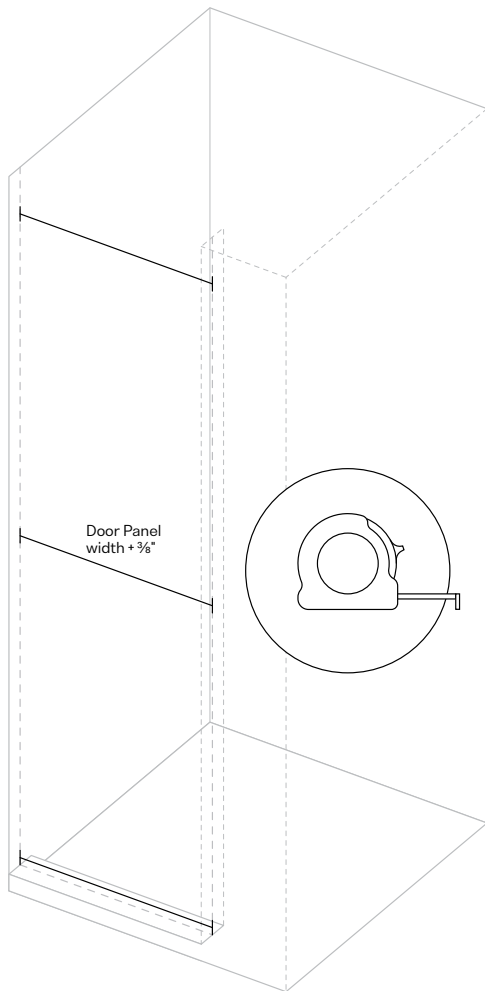

01

Measure Door Panel Opening.

Measure the opening space for your Door Panel at the top, middle and bottom. The space required needs to be a minimum $\frac{3}{8}$ " wider than the Door Panel. For example: if you have a 26" Door Panel, the opening required to fit this is a minimum 26 $\frac{3}{8}$ ". Measure the width of your Door Panel to make sure that it will fit correctly.

If you do not have enough space please contact Glass Warehouse on how to exchange this panel for another sized door.

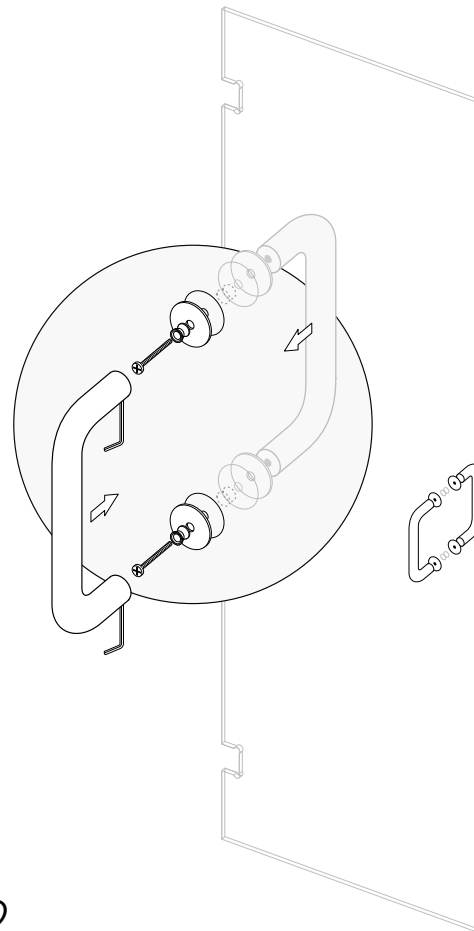

02

Attach the Door Handle to the Door Panel.

Disassemble the Door Handle and reassemble it on to the Door Panel. Note that the small plastic washers that fit within the holes in the glass are optional. Make sure all components on handle are secured very tight on door.

NOTICE

Certification Stamp: All Glass Warehouse panels include a tempered safety glass certification stamp located in one corner of each panel. Install all panels with the stamp positioned in the bottom corner closest to the wall where it will be less visible. Note: Certification stamp is baked into the glass during the tempering process and cannot be removed.

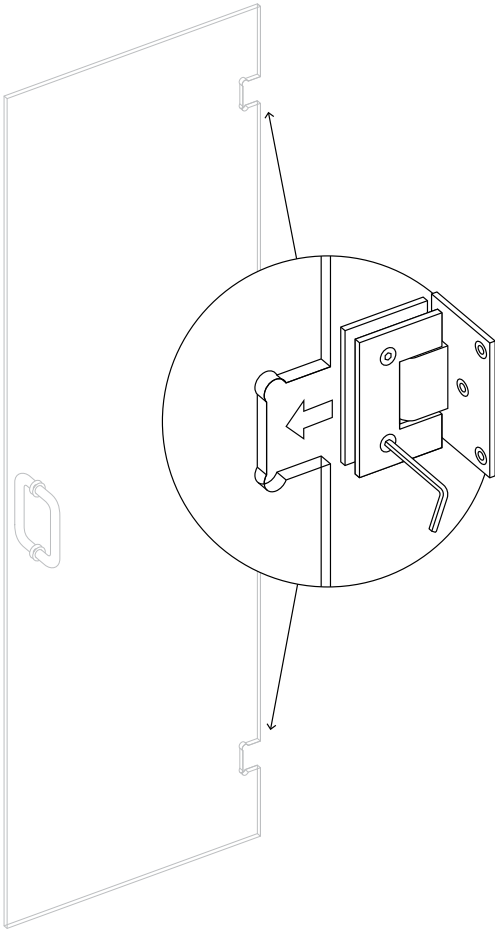

WARNING

Cardboard Packaging: Always place glass panel on cardboard or other protective surfaces during installation. Failure to use protective surfaces can cause glass to chip, crack, or shatter, creating sharp edges. Improper handling of glass can result in death or serious injury.

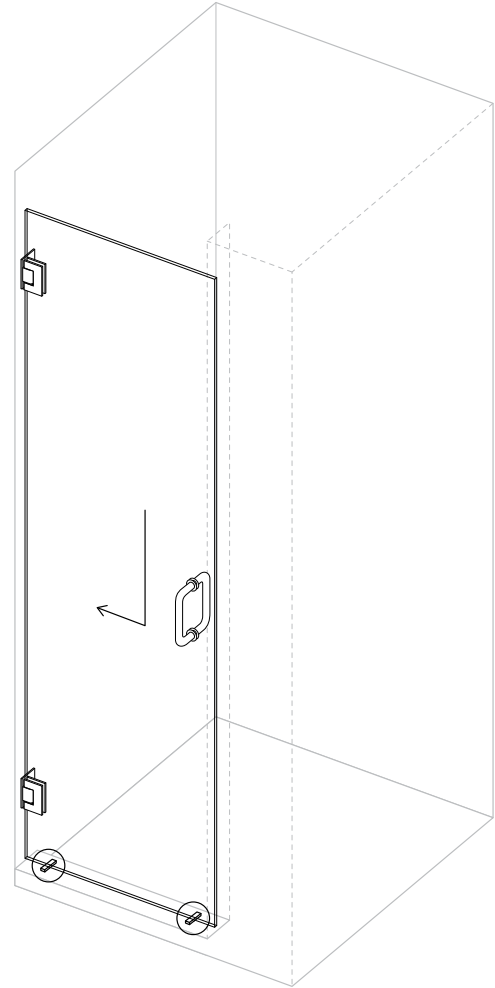

03

Attach Hinges to Door Panel.

Ensure you have the Hinges placed in the correct direction. The holes to mount the Hinge to the wall will go on the inside of shower enclosure. Lightly tighten each allen screw with the allen key provided so the hinges are only lightly secure. Hinges will be tightened further after making all adjustments. Center each Hinge to the glass cutout allowing some space to adjust the height of the Door Panel once installed.

04

Set the Door Panel in place.

Place $\frac{3}{8}$ " Rubber Blocks (that are included with the hinge) on the threshold roughly 3" from each edge of the Door Panel opening. Place some cardboard packing on the ground outside the shower where you can rest the door before installing. The honeycomb cardboard from the glass packaging is useful for this application. Carefully place the Door Panel on the Rubber Blocks.

NOTICE

Measure Corners: Use a tape measure on both corners of door panel so everything lines up and the distance is even for the entire width of your threshold.

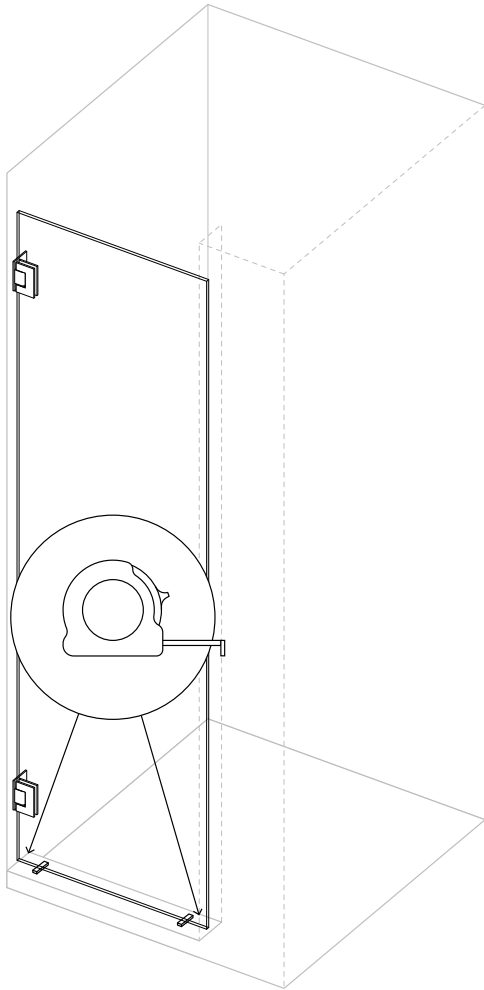

05

Check that Door Panel lines up evenly with threshold.

If the shower glass is sitting on top of a threshold, make sure the distance from the edge of the glass to the edge of the threshold is even across the entire front of the Door Panel.

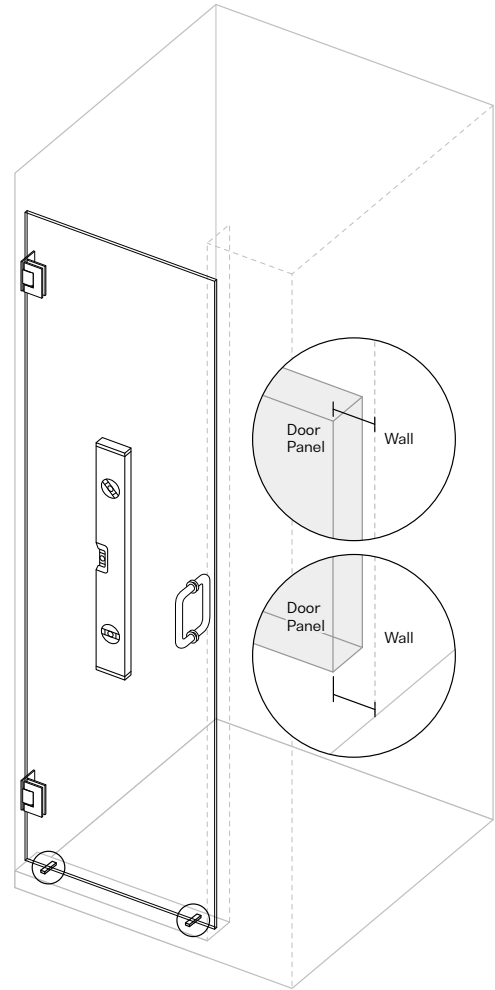

06

Level Door Panel.

Ensure the Door Panel is level and the vertical gap between the Door Panel and wall is even. It is imperative the hinge side of the Door Panel is completely level so the door will always return to its correct centered closed position. If the hinges are not installed level the weight of the door can cause the door to remain open and not return to its centered position.

WARNING

For Fiberglass Walls: When installing on fiberglass walls, ensure a stud is directly behind the panel mounting location. Failure to do so may result in structural instability, damage to the enclosure, and/or death or serious injury.

NOTICE

Pilot Hole: A 1/8" tile drill bit can be used to create pilot holes for a tiled enclosure, but this is optional.

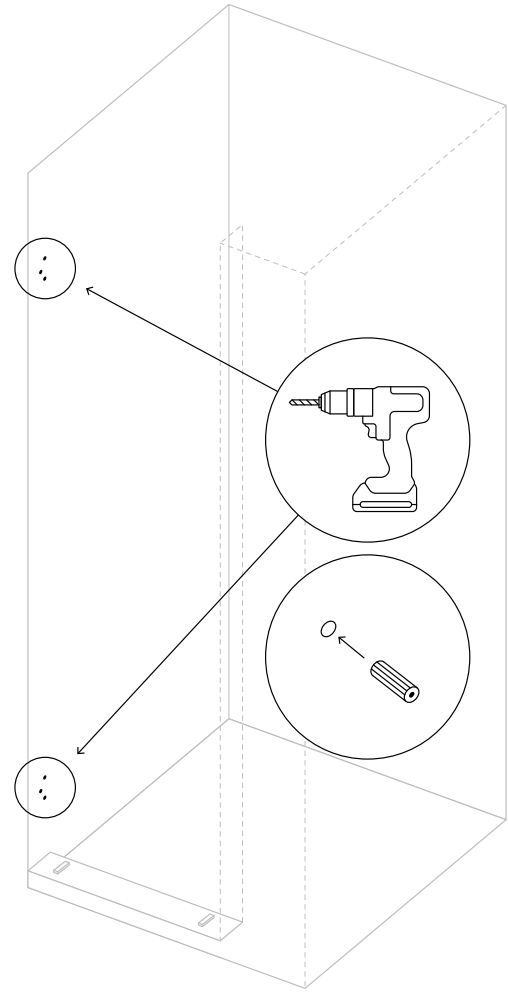
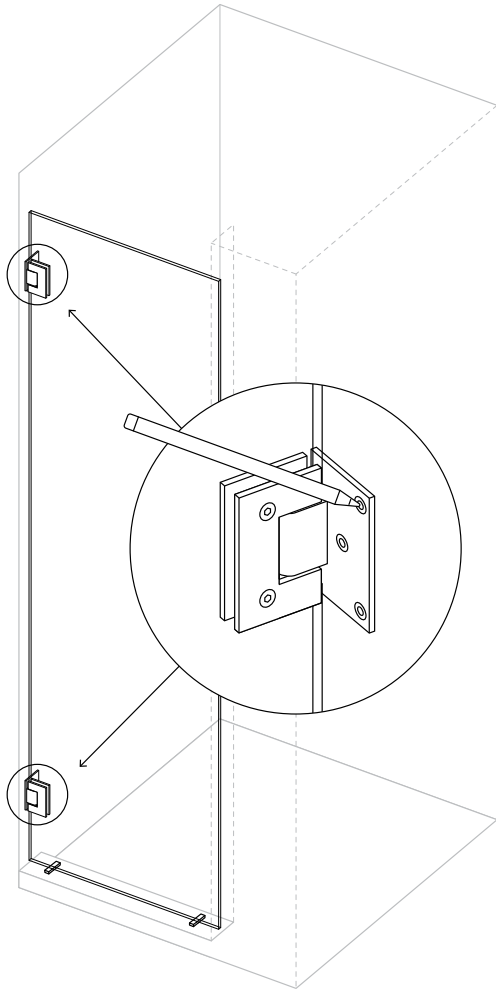

07

Mark the holes to drill for the hinges.

Once the Door Panel is perfectly level from top to bottom of glass, use a pencil or marker pen to mark the three holes for each hinge on the wall.

08

Drill holes for hinges.

Remove the Door Panel so you can drill the holes in wall for the Hinges. Drill holes for Hinges using a 1/4" tile drill bit and insert the anchors provided. Trim excess from the Wall Anchors hanging out of hole with utility knife so hinges sit flush to wall.

If the shower wall is fiberglass, use a 1/8" drill bit for the wall holes. You will not use the Wall Anchor but rather screw the Wall Clips directly into the fiberglass shower wall. Be sure there is a stud behind the wall before drilling holes.

⚠ WARNING

Use 3 Screws: Secure all three hinge screws. Failing to install all three screws on each hinge can cause the door to detach or sag, resulting in glass breakage, serious injury, or death.

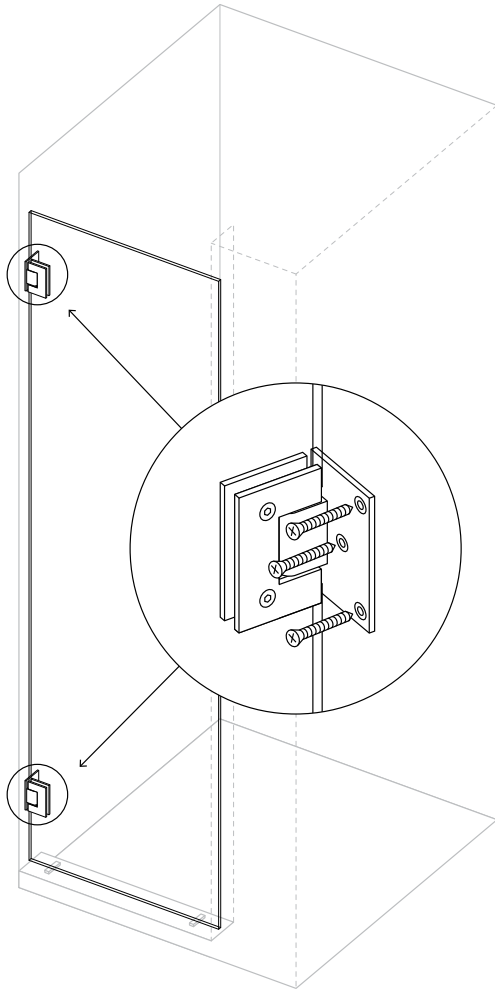

09

Install Door Panel.

Set the Door Panel back in place on the blocks. Line the Hinges over their respective holes and drill the screws in place so they are firmly secure. Make sure the gaps between the Door Panel and the wall is even and that the Door Panel is not touching the wall or the hinge plate. Using the allen key, firmly secure the screws on the hinges. Remove any rubber blocks or packing. Swing door very gently to make sure the glass is not binding anywhere.

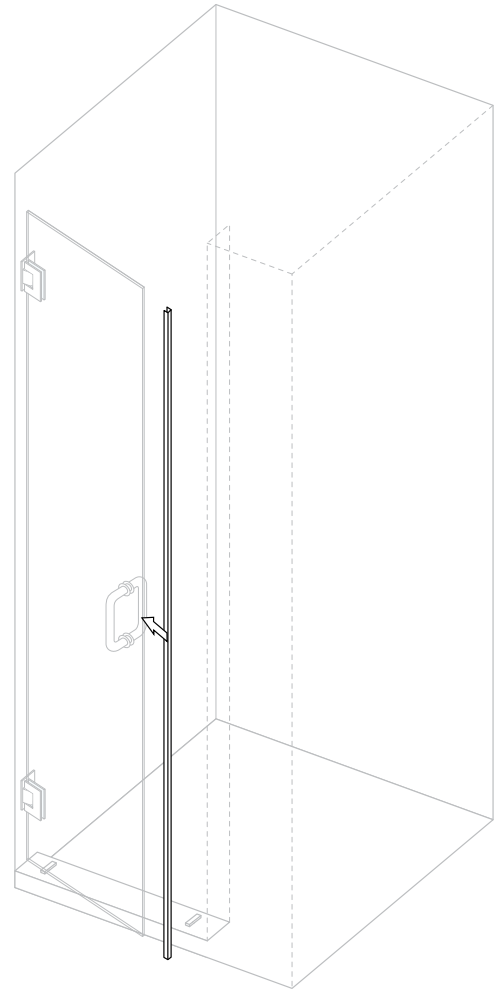

10

Install Door Panel Weather Strip.

Locate the 78" Weather Strip that will seal the space between the Door Panel and the wall. Attach the Weather Strip to Door Panel outer edge.

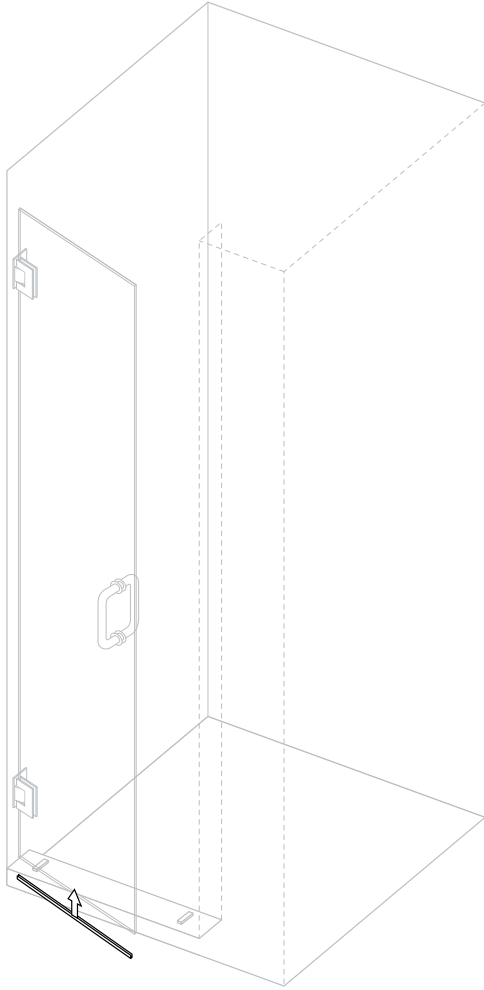

11

Install Bottom Door Sweep.

Locate the 30" door sweep. Measure the width of your door and trim the sweep to match your door size. Slide sweep on to the bottom of Door Panel to prevent any water leakage from under the door. Please make sure the bottom of the door is very clean before installing.

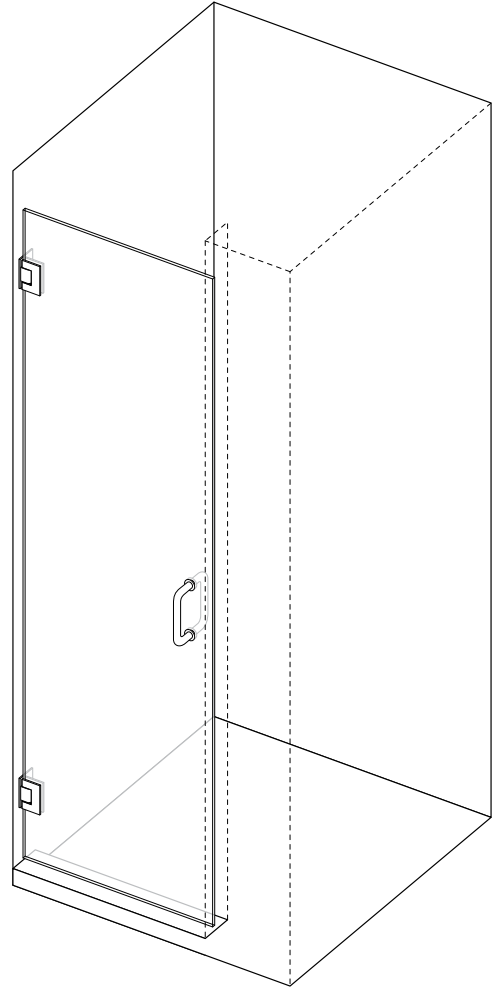

12

You're done!

Please register your warranty using the instructions on the back cover of this document.

Note: The Door Panel Bottom Sweep is optional and will not need to be installed if the Door Panel fits perfectly.

Thank you for your purchase.

If for any reason you are having trouble with installation, or if the size of the product does not fit your designated space, please contact Glass Warehouse directly and do not return this product to place of purchase. We will be able to exchange the panels or parts to suit your opening.

Glass Warehouse takes pride in providing quality products and customer service. We want to ensure your happiness with your purchase for years to come. We have an extensive range of sizes, so no matter what your measurements are, Glass Warehouse can supply the panel to fit!

If you have any questions, please do not hesitate to reach out to us. Thank you again for choosing Glass Warehouse!

Best Regards,

The Team at Glass Warehouse
Glass Warehouse, LLC
(760) 536 3640
inquiries@glasswarehouse.us

Care & Maintenance



EnduroShield makes cleaning easier and less frequent; however it is recommended that you continue to clean the surfaces regularly.

Maintaining the Treated Surface

For best results simply drying the glass with a squeegee or towel after each use will help keep the glass clean and reduce mineral spots forming. The glass needs to be cleaned every few weeks using a damp microfiber cloth and a mild detergent to break down soaps, oils, and conditioners on the glass. General glass cleaners are also suitable, however most of these are finishing agents rather than cleaners, and are an added expense that is not required.

Hard Water Maintenance

In hard water areas, or areas where water drops dry and leave a noticeable dust mark, a build of minerals may occur on the protective treatment. While these may not be removed as easily with the mild detergent, mild acids will often remove the marks quickly. As needed white vinegar should be used to wipe down the glass. Keep in mind the vinegar may be diluted with water, however dilution reduces the effectiveness.

Spray vinegar onto the glass and allow to soak for several minutes. This should dissolve any mineral deposits that have built up on the glass surface. A damp microfiber cloth should then be used to wipe over the surface. For extreme hard water areas we recommended using undiluted vinegar every week or so as a cleaning option to reduce this build up on the surface, rather than allowing the build up to continue over a long period of time.

Caution: Prohibited Products *Note these may damage the treatment and void any warranty

- Avoid the use of any abrasives or polishes including water spot removers, toothpaste, polishes, rough, or gritty substances
- Avoid the use of acids or alkalis that you would not want in contact with your skin for an extended period of time
- Avoid products such as Comet, Ajax, Jiff or Cerium Oxide which polish back the actual substrate
- Avoid the use of any harsh or chemical cleaners, with correct maintenance these are never required

Approved Cleaning Products

The below products have been tested for compatibility with EnduroShield, however there are no specific products that must be used. We feel you should not be required to purchase extra products in order to keep your glass clean. With correct maintenance, all you need for clean glass beyond 10 years is a squeegee, a mild liquid dish soap, and white vinegar.

Any product that does not fall into the prohibited categories listed above will be fine, and below is a short list of acceptable products:

- Windex
- SprayWay (or other alcohol based foaming cleaners)
- Scrubbing Bubbles (or other automatic leave-to-dry daily shower cleaners)
- 7th Generation, Dawn (or other mild eco friendly cleaners)
- CLR (Calcium Lime Rust)
- Mr. Clean Magic Eraser (when damp)

It should be noted that with any cleaner used on the EnduroShield surface a thorough rinse with clean water should follow immediately. Although these cleaners can be used, EnduroShield is designed to be an 'easy clean coating' that does not require harsh or toxic cleaning chemicals to maintain the surface effectively.

If for any reason the recommended maintenance has not been followed for some time, just as it took time for the build up to occur, it will take time to remove the debris from the protected glass surface. This can most commonly be achieved using undiluted white vinegar dampened on a Magic Eraser, or CLR on a Magic Eraser. Depending on the severity of the build up this may take multiple attempts, but once the glass is clean again it will perform like new. Should you have any queries regarding the cleaning of your treated surfaces please contact EnduroShield.

tel: 805 617 4609
email: salesusa@enduroshield.com
www.enduroshield.com



Featured Model Trinity

GLASSWAREHOUSE
GLASSWAREHOUSE.US



Reflect on a New Look

Explore our complete range of accent mirrors to compliment your new shower. Choose from many different styles, finishes, and options to give your bathroom that extra bit of style.

Exclusive Limited Warranty Terms & Conditions.

This Limited Lifetime Warranty ("Warranty") is effective as of DECEMBER 6, 2024

PLEASE READ THE WARRANTY TERMS AND CONDITIONS BEFORE PURCHASING AND BEFORE INSTALLING OR RESELLING YOUR GLASS WAREHOUSE PRODUCT. BY PURCHASE, INSTALLING, AND OR RESELLING THE GLASS WAREHOUSE PRODUCT, YOU ARE CONSENTING TO BE BOUND BY THE FOLLOWING TERMS AND CONDITIONS.

Glass Warehouse, LLC ("Seller") provides this Warranty to the business or individual ("Buyer") who purchases a Glass Warehouse product ("Product") directly from Seller or from an authorized reseller, including without limitation, shower kits, railing hardware, medicine cabinets, and mirrors. If Buyer is a licensed and fully insured professional and Buyer installs the Product in the residence of one of Buyer's customers ("Customer"), Buyer may pass this Warranty through to such Customer. In each case, this Warranty shall extend only to the original Buyer or Customer at the time of installation and shall expire if the original Buyer or Customer no longer owns or occupies the residence at which the Product is first installed. This Warranty will not apply to any subsequent owners or occupants of the residence. "Products" do not include, and this Warranty specifically excludes: (i) any products sold by Glass Warehouse under brand names other than Glass Warehouse; (ii) any third-party products distributed or sold by Glass Warehouse that are not incorporated into a Glass Warehouse Product.

Limited Lifetime Warranty for Glass

With respect to any glass components of the Product, Seller warrants to Buyer that for the lifetime of the Product ("Glass Warranty Period"), that such components (excluding seals) will materially conform to Seller's published specifications and will be free from material defects in material and workmanship. With respect to any Product used in commercial, industrial, or non-residential uses, including without limitation hotels, casinos, and apartments, the Glass Warranty Period is one (1) year. For mirrors, including medicine cabinets with mirrors, the Glass Warranty Period is one (1) year. For glass railings, the Glass Warranty Period is three (3) years. The Glass Warranty Period with respect to the outer coating of any glass component, such as an Enduroshield coating, is five (5) years.

Limited 5-Year Warranty for Hardware

With respect to any hardware components of the Product, Seller warrants to Buyer that for a period of five (5) years from the date of Buyer's purchase of the Product ("Hardware Warranty Period"), that such components (excluding seals) will materially conform to Seller's published specifications and will be free from material defects in material and workmanship. With respect to any

Product used in commercial, industrial, or non-residential uses, including without limitation hotels, casinos, and apartments, the Hardware Warranty Period is one (1) year. For mirrors, including medicine cabinets with mirrors, the Hardware Warranty Period is one (1) year. For railings, the Hardware Warranty Period is one (1) year. The Glass Warranty Period and Hardware Warranty Period are referred to together as the "Warranty Period."

While stainless steel is resistant to corrosion, it is not corrosion or rust-proof. Environmental conditions including, but not limited to, exposure to chemicals, salt air, pollution, and high humidity may cause surface discoloration or rust. Regular cleaning and maintenance is required to maintain the appearance and integrity of stainless steel products. Seller makes no warranty against and shall not be liable for any claims related to surface rust, discoloration, or corrosion of stainless steel components.

Warranty Terms and Conditions

This Warranty shall be voided if the Product (i) has been subjected to abuse, misuse, neglect, negligence, accident, improper testing, improper installation, improper cleaning (such as use of abrasive cleaners), improper storage, improper handling, abnormal physical stress, abnormal environmental conditions, or use or installation contrary to any instructions or guidelines issued by Seller; (ii) has been altered, repaired, or reconstructed by anyone other than Seller; (iii) was installed by anyone other than a fully insured and licensed professional; (iv) was not installed according to Glass Warehouse's published installation instructions or guidelines; (v) is installed or used outside of the US or Canada; or (vi) has been used with any third-party hardware or product that has not been previously approved in writing by Seller. This Warranty shall not apply to normal wear and tear. With respect to Products advertised by Glass Warehouse for outdoor use, this Warranty specifically excludes damage caused by extreme weather events.

WARNING: INSTALLATION OF GLASS PRODUCTS (I.E., SHOWER AND TUB DOORS) BY AN UNLICENSED OR INEXPERIENCED INSTALLER MAY RESULT IN GLASS BREAKAGE, DAMAGE TO PROPERTY, SERIOUS INJURY OR DEATH.

Neither Buyer, nor any other person is permitted to make any affirmation, representation, or warranty other than those contained in this Warranty. Any affirmation, representation, or warranty other than those contained in this Warranty shall not be enforceable against Seller or any other person. Seller reserves the right to modify this Warranty at any time, it being understood that such modifications will not alter the terms and conditions applicable at the time of sale of the products in question.

Please register your information to activate your warranty.
<https://www.glasswarehouse.us/warranty/>

Claims Process and Remedies:

All Warranty claims are subject to review and confirmation by Seller, and Seller reserves the right to inspect the installation to confirm the validity of the Warranty claim. To submit a Warranty claim, Buyer must:

1. Contact Seller's customer service department within 30 days of discovering the defect. Contact information:
Phone: +1 (760) 536-3640
Email: inquiries@glasswarehouse.us
<https://www.glasswarehouse.us/warranty/>.
2. Provide the following required documentation: (a) proof of purchase; (b) detailed description of the defect, including photographs; (c) item part number.
3. A customer service representative will review the claim and may request additional information or schedule an inspection of the Product and/or installation. Buyer must cooperate fully with any requests for information or inspection.

Seller shall have no obligation to honor any Warranty claim that does not comply with the above claims process. If a Warranty claim is approved, Seller shall, in its sole discretion, either: (i) repair or replace such Product (or the defective part), in which case Seller shall cover shipping of the repair parts or replacement product; or (ii) refund the price paid by Buyer to Seller for such Product. Replacement parts and products will be covered by this Warranty for the remainder of the Warranty Period of the original Product. Seller may require that the Product be returned to Seller, at Seller's expense. Except for any repairs made by Seller or its representatives as set forth above, Seller shall not pay for labor related to the Warranty claim, such as removal of the defective Product or installation of a replacement product. Seller's warranty obligation shall be discharged upon tender of parts, replacement or repair of the Product. Buyer's refusal to accept the tender terminates all warranty obligations and **VOIDS THIS WARRANTY.**

THE REMEDIES SET FORTH ABOVE SHALL BE BUYER'S SOLE AND EXCLUSIVE REMEDY AND SELLER'S ENTIRE LIABILITY FOR ANY BREACH OF THIS WARRANTY.

Disclaimer and Limitation of Liability:

EXCEPT FOR THE PRECEDING WARRANTY, SELLER MAKES NO WARRANTY TO BUYER WHATSOEVER WITH RESPECT TO THE PRODUCTS AND HEREBY DISCLAIMS ALL OTHER WARRANTIES, INCLUDING ANY (I) WARRANTY

OF MERCHANTABILITY; (II) WARRANTY OF FITNESS FOR A PARTICULAR PURPOSE; OR (III) WARRANTY AGAINST INFRINGEMENT OF INTELLECTUAL PROPERTY RIGHTS OF A THIRD PARTY; WHETHER EXPRESS OR IMPLIED BY LAW, COURSE OF DEALING, COURSE OF PERFORMANCE, USAGE OF TRADE OR OTHERWISE.

SELLER DISCLAIMS AND SHALL NOT BE LIABLE FOR ANY PERSONAL INJURIES OR DEATH TO ANY PERSON, INCIDENTAL DAMAGES, CONSEQUENTIAL DAMAGES, LOSS OF PROFITS, LOSS OF USE, LABOR OR MATERIAL CHARGES, OR ANY OTHER COSTS RELATING TO THE USE OR INABILITY TO USE THE PRODUCT OR REPLACEMENT PRODUCT OR RELATING TO THE APPLICATION OF THIS WARRANTY. IN NO EVENT SHALL SELLER'S AGGREGATE LIABILITY EXCEED THE PURCHASE PRICE OF THE PRODUCT.

SOME STATES LIMIT A MANUFACTURER'S ABILITY TO DISCLAIM CERTAIN WARRANTIES OR LIABILITIES AND THEREFORE SOME OF THE ABOVE DISCLAIMERS OR LIMITATIONS OF LIABILITY MAY NOT APPLY TO YOU.

Warranty Service

To activate your limited lifetime warranty, please visit:
<https://www.glasswarehouse.us/warranty/>



Please register your information within 30 days of purchase to complete the activation of your warranty.

Contact Technical Support:

**Monday – Friday 8am – 5pm PST
Technical Support: +1 (760) 536-3640**

GLASSWAREHOUSE

Register Your Warranty Today!

To activate your limited lifetime warranty, please visit:
<https://www.glasswarehouse.us/warranty/>



We will require this information within 30 days of purchase to complete the activation of your warranty.