

#### Before assembly

- We recommend that time is taken to read the instructions before starting assembly, then follow the easy step by step guide. The instruction sheet is only a guide to the assembly. Certain items may not be shown to scale.
- Check all components prior to assembly
- This product should be assembled by no less than two people
- Drill all components where indicated



#### Recommended tools for assembly

- Power Drill/Screwdriver
- Cross-head drill bit
- 3mm diameter drill bit
- Tape measure
- Spirit level

#### Biocidal Products Regulation EU 528/2012

Wolmanit® CX treated wood, is a treated article incorporating biocidal products: copper hydroxide carbonate, bis(N-cyclohexyl-diazonium-dioxy)-copper and Boric Acid. They protect wood against fungal decay, rot and insect attack. Wear gloves when handling freshly treated wood. Avoid breathing dust when cutting wood. Dispose of off-cuts responsibly.

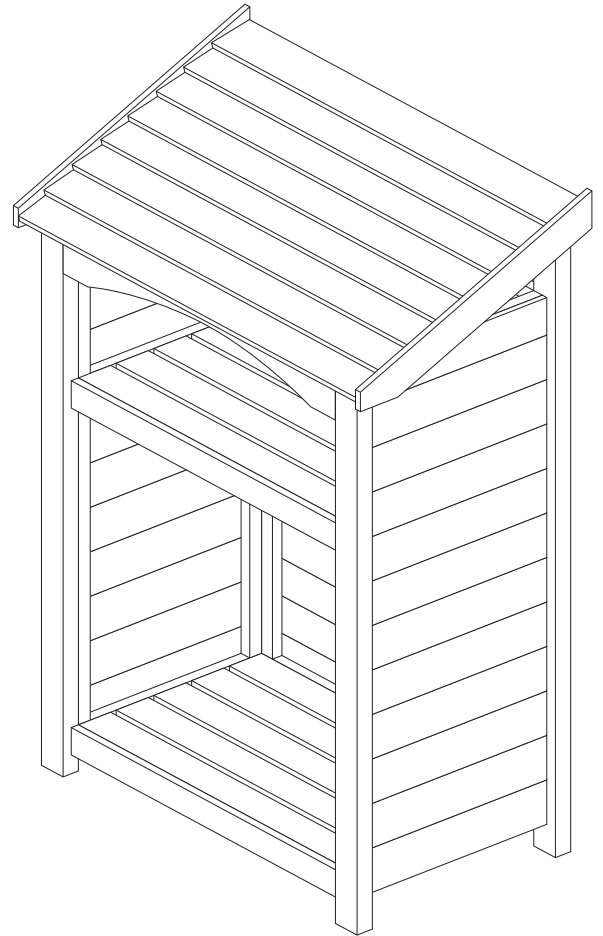

No.	Components	Qty.
1	Front upright (1428mm)	2
2	Rear upright (1670mm)	2
3	Side panel	2
4	Back panel	1
5	Short shelf support (45x28x470mm)	2
6	Long shelf support (45x28x810mm)	1
7	Floor/Shelf	2
8	Roof rear strip (16x45x1090mm)	1
9	Roof panel	1
10	Fascia arch	1
11	Fascia support block (28x28x95mm)	2
12	Floor/Shelf fascia (21x70x880mm)	2
13	Bargeboards	2

No.	Fixing Kit	Qty.
14	60mm Screw	22
15	50mm Screw	20
16	40mm Screw	32

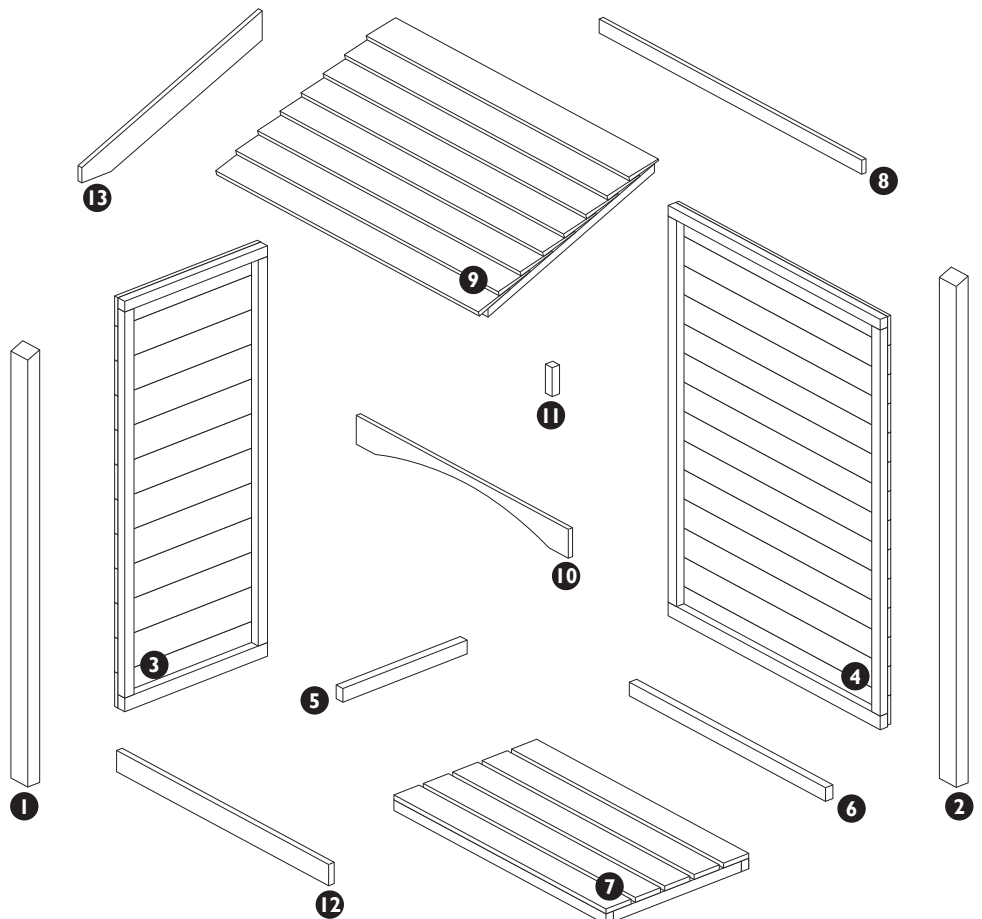

## 1. Side panels and uprights

No.	Components for this section	Qty.
1	Front upright (1428mm)	2
2	Rear upright (1670mm)	2
3	Side panel	2

Fixings for this section		
14	60mm screws	12

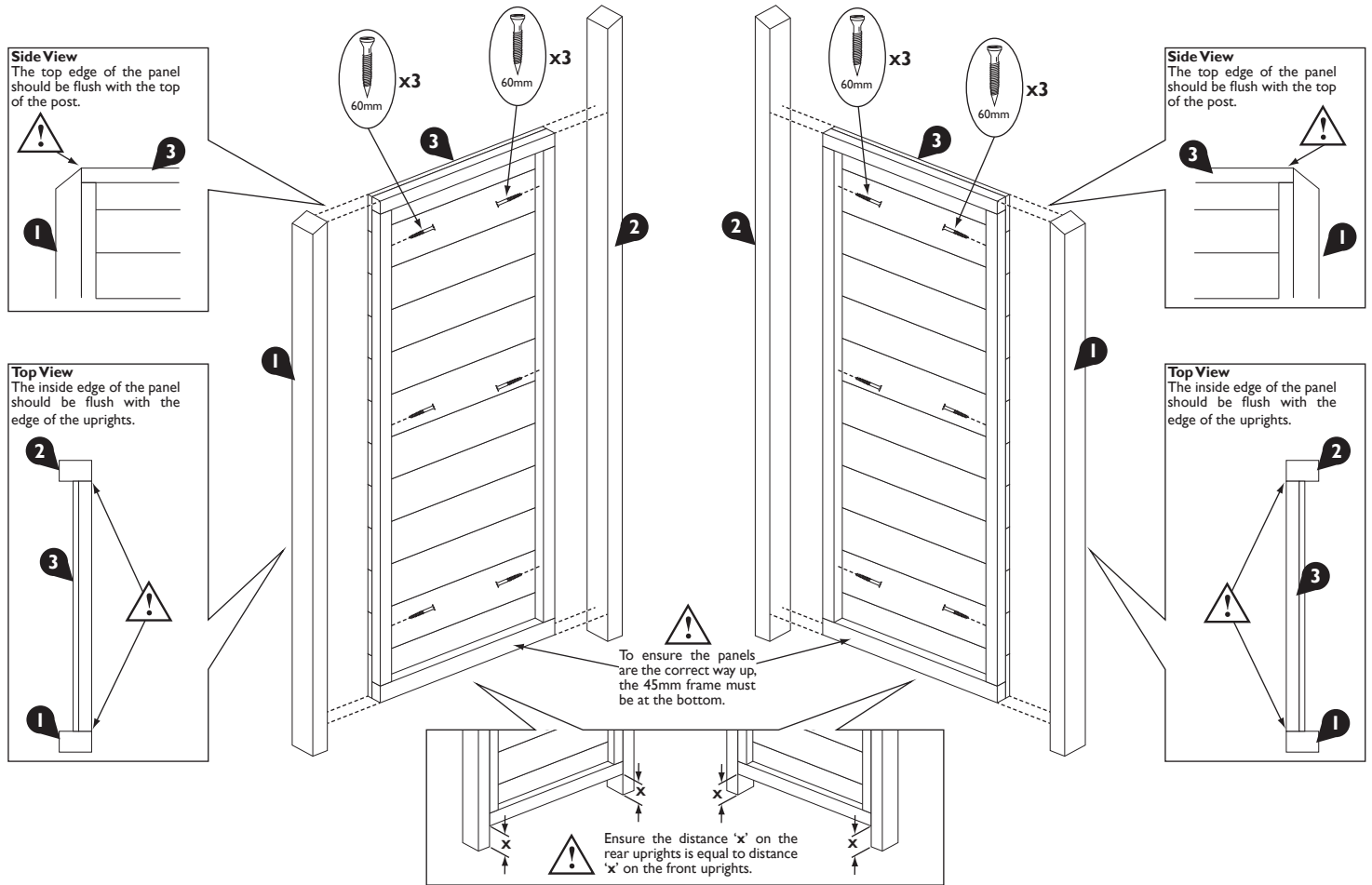

## 2. Back Panel

No.	Components for this section	Qty.
4	Back panel	1

Fixings for this section		
14	60mm screws	6

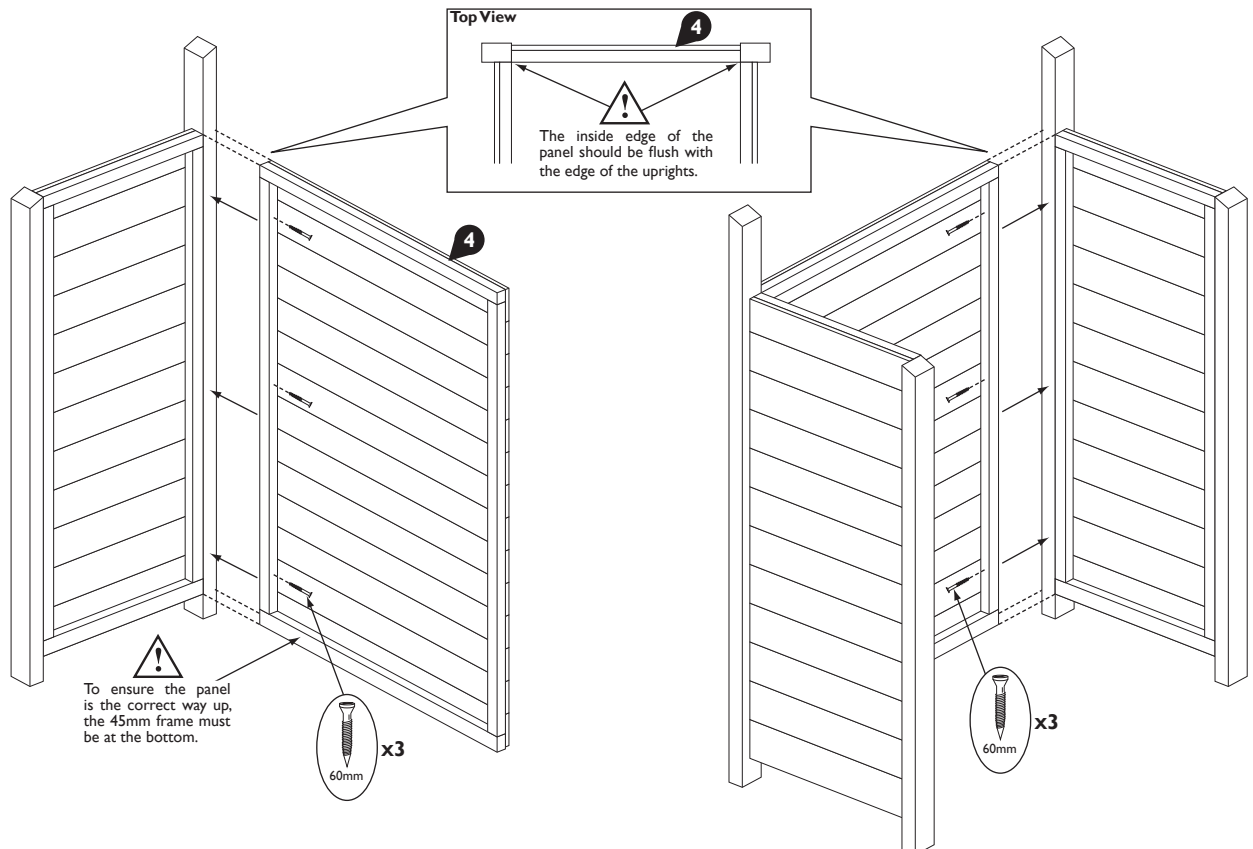

### 3. Shelf Support Rails

No.	Components for this section	Qty.
5	Short shelf support (45x28x470mm)	2
12	Long shelf support (45x28x810mm)	1

Fixings for this section	
16	40mm screws
9	

 Fit the Shelf support rails at the desired height. Secure through the panel cladding into the support rails. Ensure all rails are level and all three are at the same height.

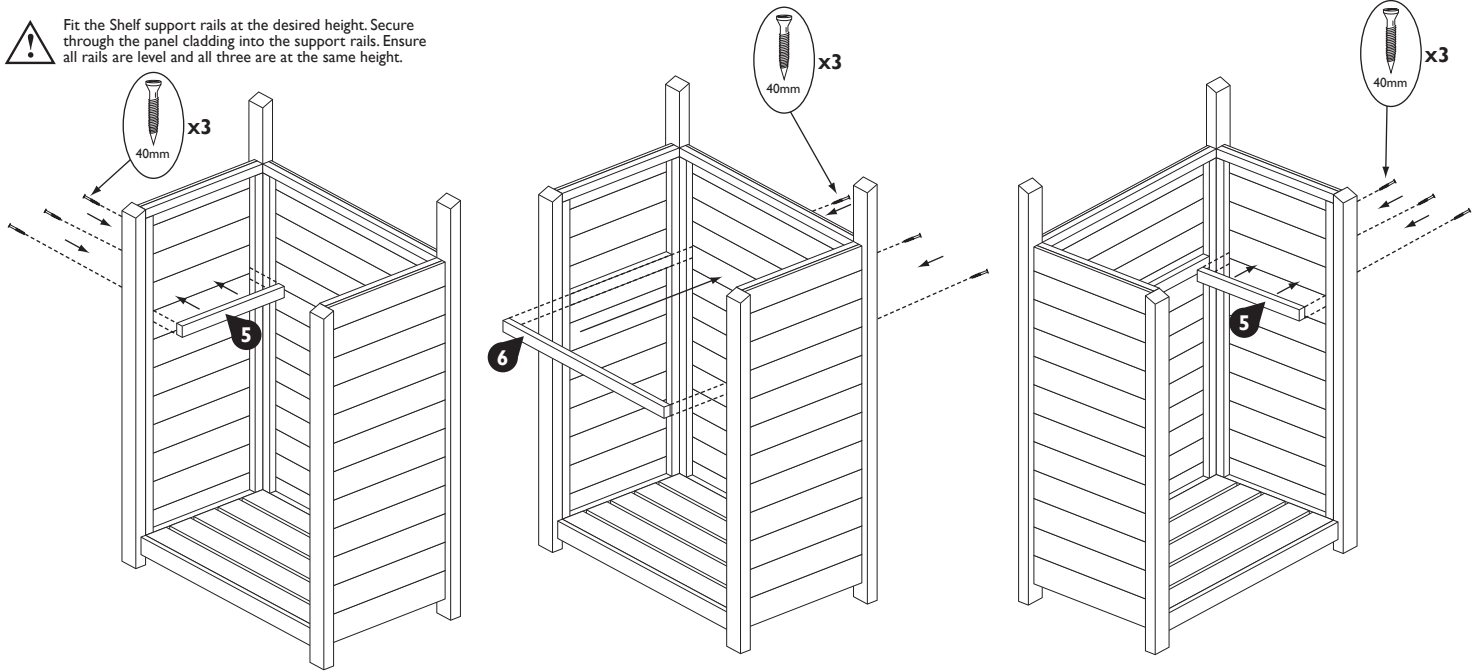

### 4. Floor & Shelf

No.	Components for this section	Qty.
7	Floor/Shelf	2
12	Floor/Shelf fascia (21x70x880mm)	2

Fixings for this section		
15	50mm screws	20
16	40mm screws	6



To fit the floor and shelf, it may be easier to carefully lay the unit on its back to allow better access to the screws.



Position the shelf inside with the top of the Shelf flush with top edge of the shelf support framing.



Position the floor inside with the top of the floor flush with top edge of the side and back panel framing.

**View of underside of shelf**  
Secure through the shelf frame into the shelf support rails.

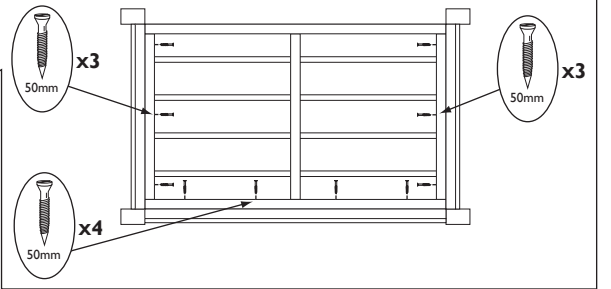

**View of underside of floor**  
Secure through the floor frame into the panel frame.

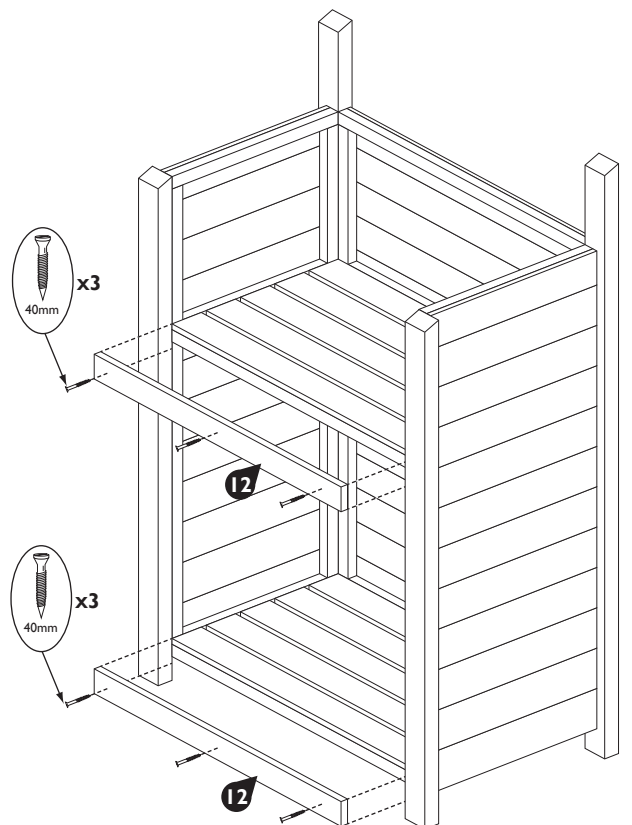
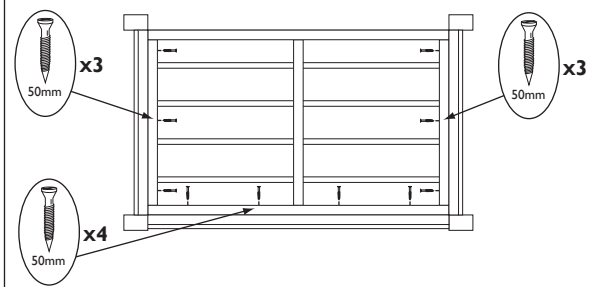

## 5. Fascia Arch

No.	Components for this section	Qty.
10	Fascia arch	1
11	Fascia support block (28x28x95mm)	2

Fixings for this section		
16	40mm screws	8

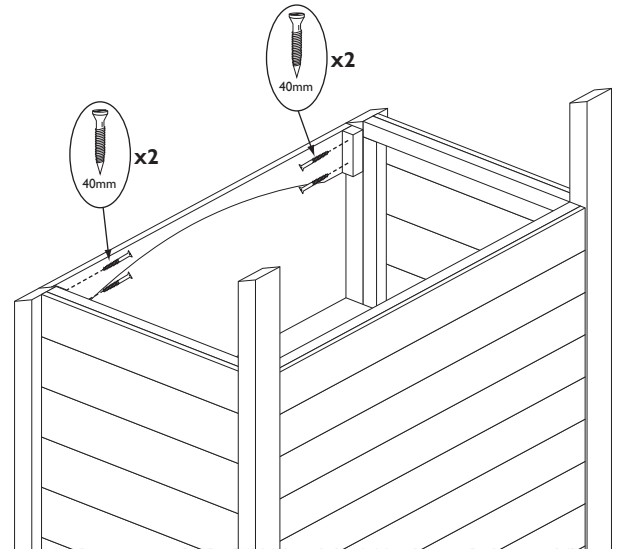
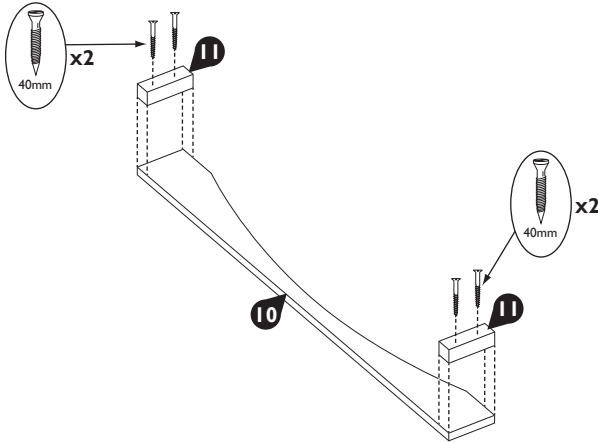

## 6. Roof & Bargeboards

No.	Components for this section	Qty.
8	Roof rear strip (16x45x1090mm)	1
9	Roof	1
13	Bargeboards	2

Fixings for this section		
14	60mm screws	4
16	40mm screws	9

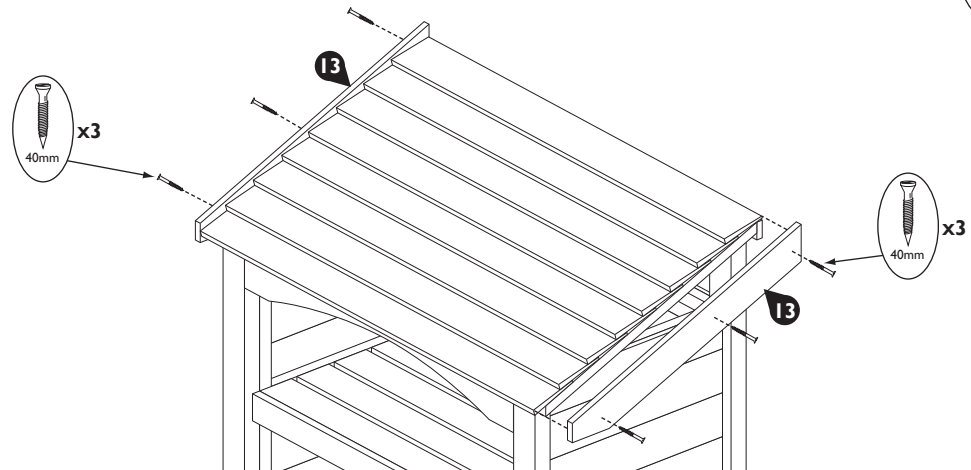
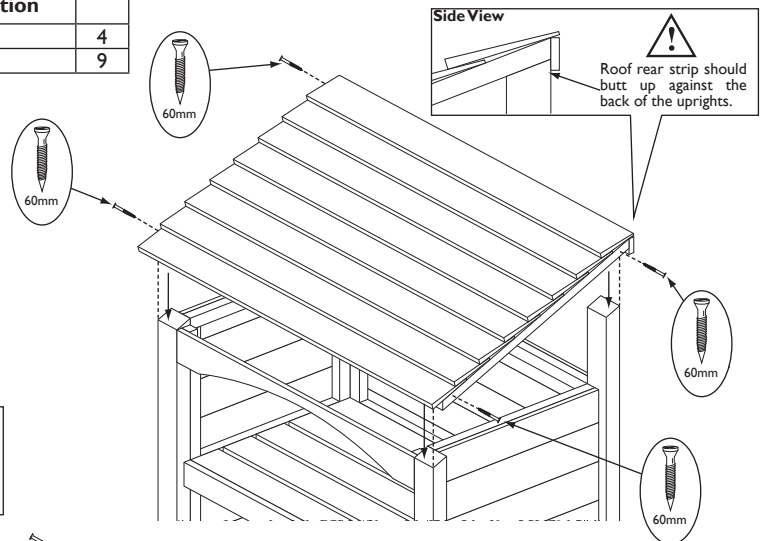
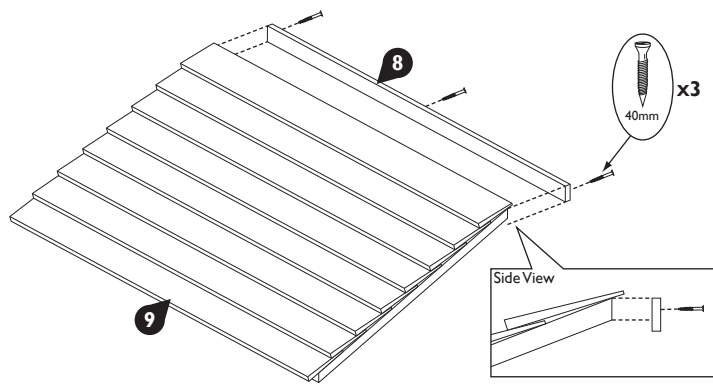

### Important information - retain for future reference

Pressure treated buildings require no further preservative treatment, However they can be painted or stained if required.

Timber Information.

As timber is a natural material, there are certain weather conditions that may affect the materials properties. In times of excessive dry spells the material may lose some of its internal moisture causing a certain degree of shrinkage on a panel and in periods of excessive rain there will be a certain amount of swelling throughout the wooden panels. This process can not be avoided. If you have problems with certain boards shrinking in dry spells try to decrease the amount of direct sunlight on the building or the amount of air passing over the building.

If in doubt of any aspect regarding the assembly, use or safety of your Log Store please contact us:

**Help Line: (Normal Office Hours) 01829 261 121**

**Email: [support@rowgar.co.uk](mailto:support@rowgar.co.uk)**

ROWLINSON GARDEN PRODUCTS LIMITED  
Green Lane  
Wardle Nr. Nantwich  
Cheshire  
CW5 6BN  
[www.rowgar.co.uk](http://www.rowgar.co.uk)

We constantly improve the quality of our products, occasionally the components may differ from the components shown and are only correct at time of printing. We reserve the right to change the specification of our products without prior notice.

**2024 © Rowlinson Garden Products Ltd**