

NOTICE

- * Please make sure that you have all parts indicated and they are in good condition before you begin assembly of this item. Refer to part list and hardware list below for guidance.
- * This item should be assembled on a soft surface to prevent scratching the finish during assembly.
- * This item may require periodic tightening.
- * If you are having difficulty, our friendly Customer Care team is always here to help. Please Email customersupport@safavieh.com

PREPARATION

- * Before beginning assembly of product, make sure all parts are present. Compare parts with part contents list and hardware contents list.
- * If any part is missing or damaged, do not attempt to assemble the product.
- * Estimated Assembly Time: 10 minutes.
- * Tools Required for Assembly (included): Allen Key

CARE AND MAINTENANCE

WOOD CARE: Adhesive felt pads should always be applied to areas of furniture which make direct contact with flooring, said application will prevent damage to the furniture and or surfaces on which the furniture lies. Objects placed on articles of furniture should rest on nonabrasive material as to prevent damage to the wood finish. Wipe up spills immediately and avoid common hazards such as hot dishes, harsh solvents and abrasives. Cleaning should be done with a soft lint free cotton cloth dampened with water or furniture polish.

UPHOLSTERY CARE: To prevent overall soiling, frequent vacuuming or light brushing is recommended. Cushions and pillows should be turned on a weekly basis. Down-filled cushions should be brushed rather than vacuumed. Spot clean, using a mild water-free solvent or dry cleaning product. Only a professional cleaner should undertake a complete overall cleaning. The use of steam or water-based cleaners may cause excessive shrinking or staining.

ITEM ID: BST5606



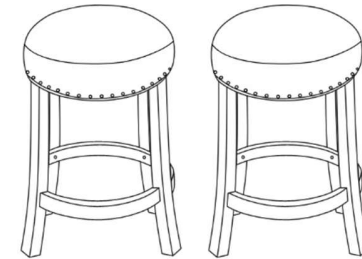



ITEM DIMENSION: 23 1/4" x 23 1/4" x 29"



⚠ WARNING ⚠

Weight Capacity - 225 LBS
Warning : Do not stand on chair
Warning : Do not over torque bolts.

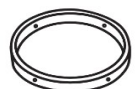
Part List and Hardware List

PIECE	DISCRIPTION	PICTURE	QTY	PIECE	DISCRIPTION	PICTURE	QTY
A	Cushion Seat		1x	HW1	Socket Bolts M6x1.0x35mm		8x
B	Chair Leg		4x	HW2	Split Lock Washer 6mm		8x
C	Leg Support		1X	HW3	Allen Key M4		1x

PREPARATION

- * Before beginning assembly of product, make sure all parts are present. Compare parts with part contents list and hardware contents list.
- * If any part is missing or damaged, do not attempt to assemble the product.
- * Estimated Assembly Time: 10 minutes.
- * Tools Required for Assembly (included): Allen Key

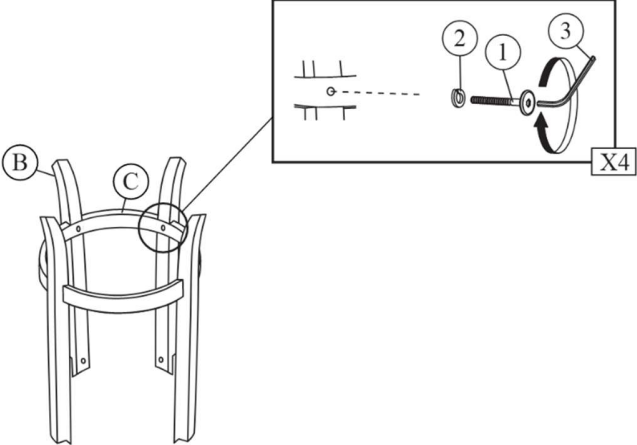
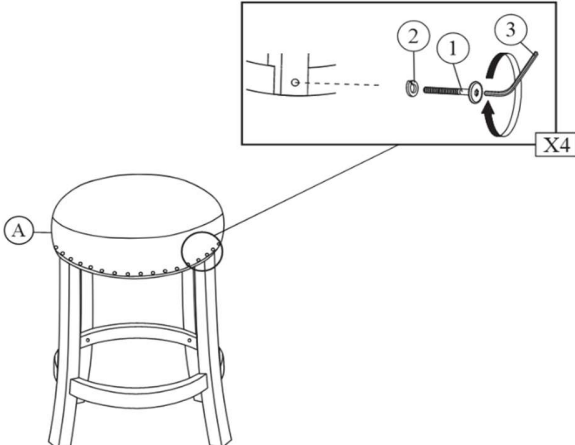
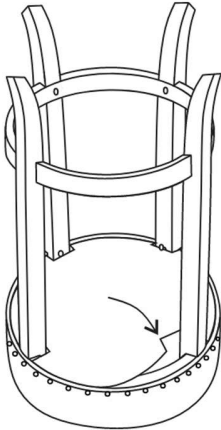
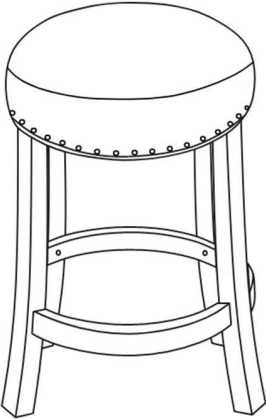
	
<p>Step 1: Attach the Chair Leg (B) to the Leg Support (C), using Socket Bolts (HW1), Split Lock Washer (HW2), and Allen Key (HW3). Do not fully tighten the bolts yet.</p>	<p>Step 2: Attach the Cushion Seat (A) to the Chair Leg (B), using Socket Bolts (HW1), Split Lock Washer (HW2), and Allen Key (HW3). Now, make sure all four legs are balance and tighten all the bolts securely.</p>
	
<p>Step 3: Place the Seat Base Cover back underneath the Chair Seat (as show in the picture) in its original position. Press down firmly on the magic tape edges to secure the cover.</p>	<p>Step 4: Assembly complete. Enjoy your counter stool!</p>