

# Bench

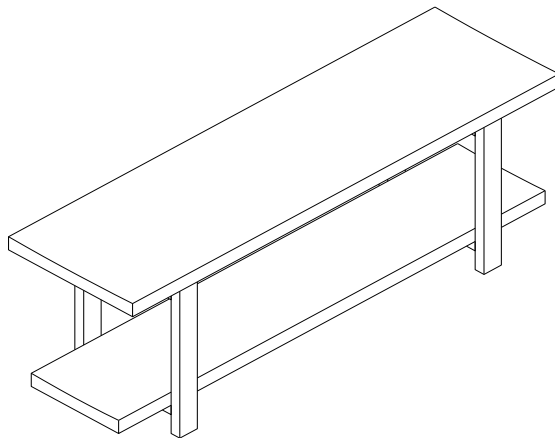





Thank you for purchasing our Bench. **We have found it helpful to have a second person present in at least one step of the assembly.**

---

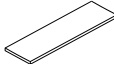
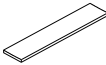
## Assembly Instructions

Lay out all parts on a "non-abrasive" surface to avoid scratching furniture.

NO.	DRAWING	DESCRIPTION	QTY.
A		TOP	1
B		SHELF	1
C		SIDE PANEL	2
NO.	DRAWING	DESCRIPTION	QTY.
D		M6*70mm BOLT	6
E		M6*45mm BOLT	4
F		WRENCH	1

### Step 1

Read through these instructions thoroughly before beginning assembly. We have found this to be of great value when first assembling this product.

### Step 2

Remove all parts and hardware from packing material. Wooden pieces should be placed on a non

abrasive surface (like the carton or carpet) to prevent damage to the finish.

### Step 3

Lay Top (A) upside down and attach 2 Side Panels (C) by using 6 6M x 70mm Bolts (D).  
**DO NOT TIGHTEN FIRMLY AT THIS TIME.**

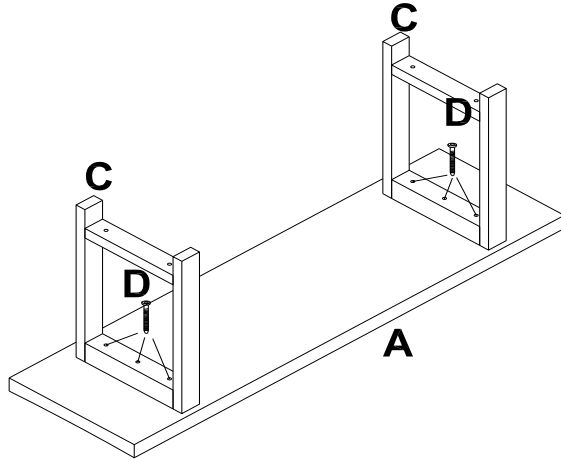

### Step 4

Note: It will help to have a second person at this time to assist in assembly.  
Lay on side and attach Shelf (B) to Side Panels (C) using 4 6M x 45mm Bolts (E).

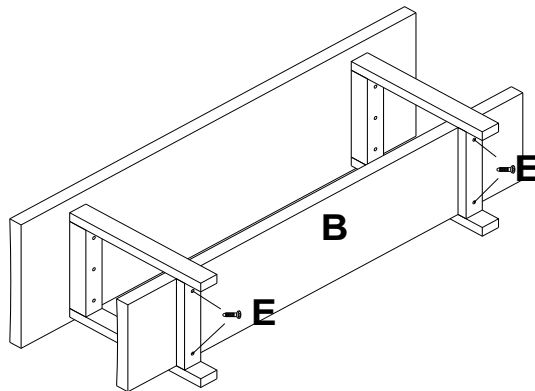

**TIGHTEN ALL BOLTS FIRMLY AT THIS TIME.**

---

### CARE

Clean with mild soap and wipe dry.

---

### REPLACEMENT PARTS:

Use the order form on the web site to order your replacement parts. **Thank You!**