









Assembly Instructions

Caution : You must read this before you proceed .

Care & Maintenance

- ⊘  ● Not for commercial use. For residential use only.
- ⊘  ● Do not put hot items directly on furniture surface.
- ⊘  ● Do not clean furniture with harsh cleansers or polish.
- ✓  ● To obtain the longest lifespan of your outdoor products, minimizing exposure to direct sunlight is recommended.
- ⊘  ● Children should not climb or jump on the furniture.
- ⊘  ● Do not write on furniture without a padded barrier to protect the surface.
- ✓  ● To obtain the longest lifespan of your outdoor products, avoid extended and lengthy exposure to rain, snow, and direct sunshine. Whenever possible cover the product and /or place under patio or awnings.
- ⊘  ● Stains may be removed with mild soap solution and damp cloth.
- ✓  ● Dust and pick-up spills using a clean, non-colored, lint-free cloth.

Assembly Instructions

CORNER SET

Please look into the **Hardware Box in Carton 2 of 2** for all hardware.

Please look in the **Corner Backrest Panel** for all hardware

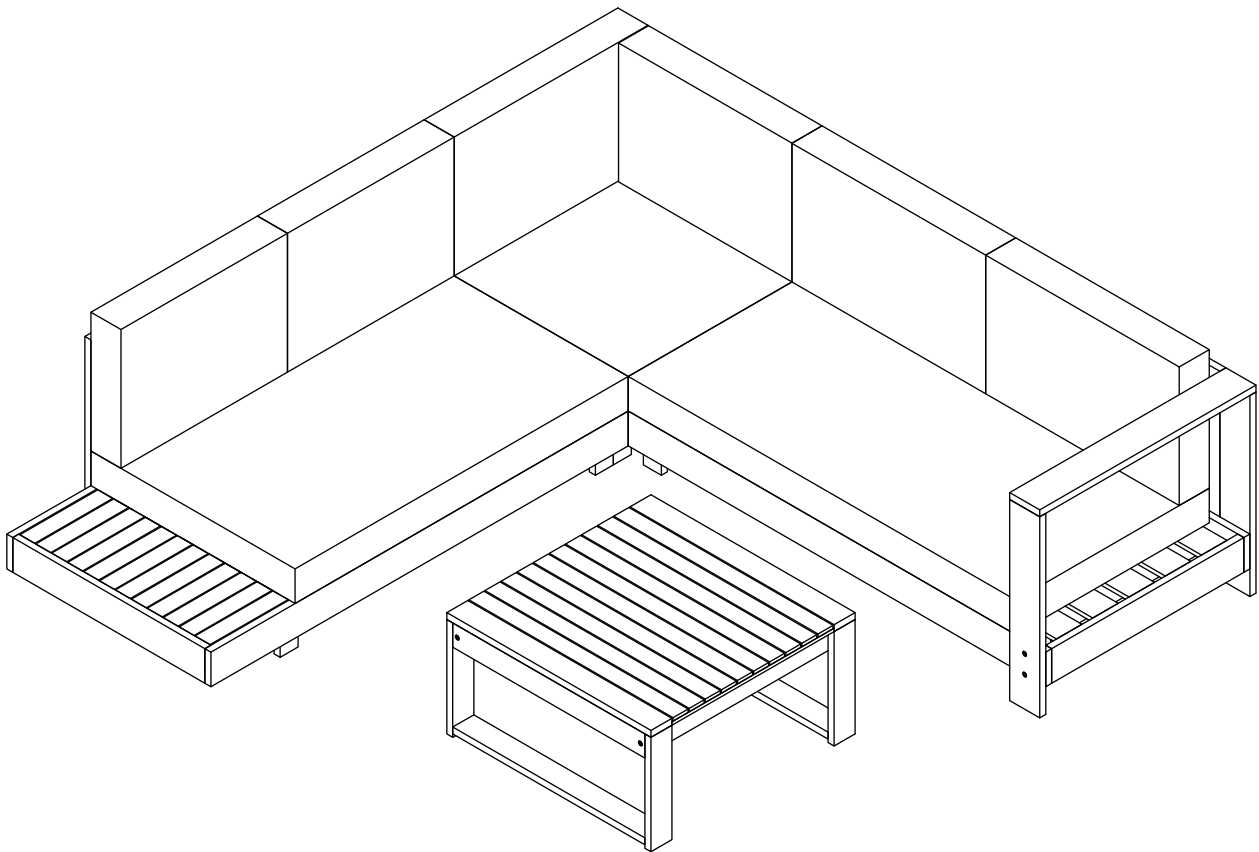

Caution: This Corner Set is NOT a TOY.

Keep your child / children at bay in the process of assembly.

Whenever moving or lifting the Corner Set and to prevent any damage to it, two adults may be needed to execute these actions.

Parts List

Box 1

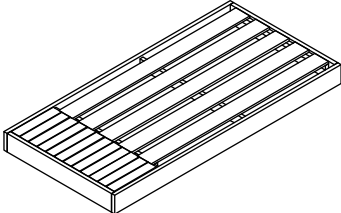
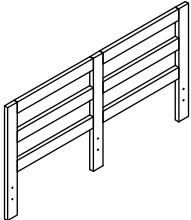
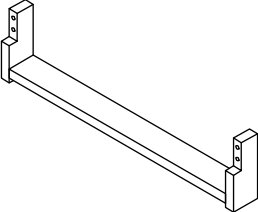
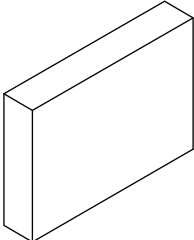
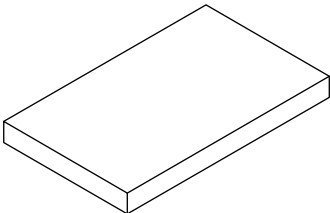
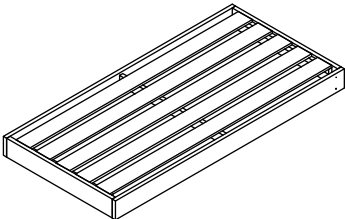
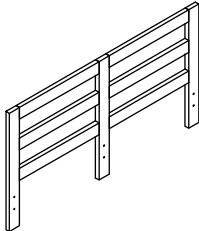
No.	Picture	Description	Qty
A1		Left Chair Seat Panel	1
B1		Left Chair Backrest Panel	1
C1		Short Leg Panel	3
D1		Left Chair Back cushion	2
E1		Left Chair Seat cushion	1
F1		Right Chair Seat Panel	1
G1		Right Chair Backrest Panel	1

Parts List

Box 1

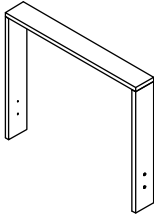
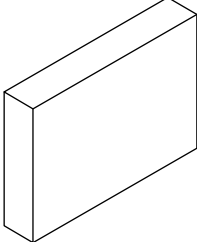
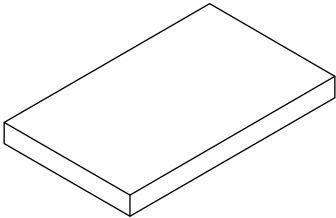
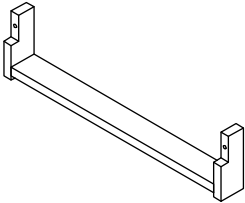
No.	Picture	Description	Qty
H1		Right Chair Leg Panel With Arm	1
I1		Right Chair Back Cushion	2
J1		Right Chair Seat Cushion	1
K1		Corner Leg Panel	2

Box 2

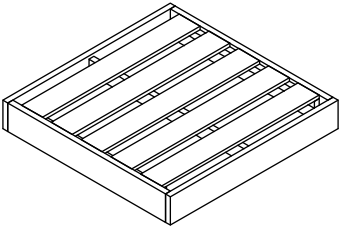
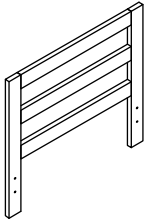
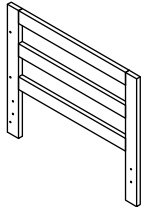

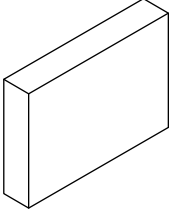
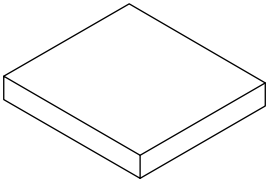
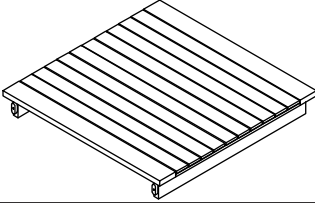
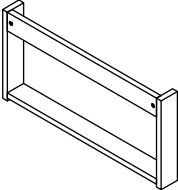

A2		Corner Seat Panel	1
B2		Corner Backrest Panel 1	1
C2		Corner Backrest Panel 2	1

Parts List

Box 2

No.	Picture	Description	Qty
D2		Corner Back Cushion	2
E2		Corner Seat Cushion	1
F2		Table Top	1
G2		Table Leg Panel	2

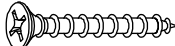
Hardware List (Box 2)

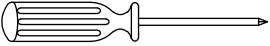
No.	Picture	Description	QTY
1		Bolt M6 x 30 mm	35
2		Washer	21
3		Screw M4 x 30 mm	4
4		Screw M6 x 45 mm	5
5		Allen Wrench	2
6		Screw driver	Not provided

Assembly Steps

OVERVIEW:

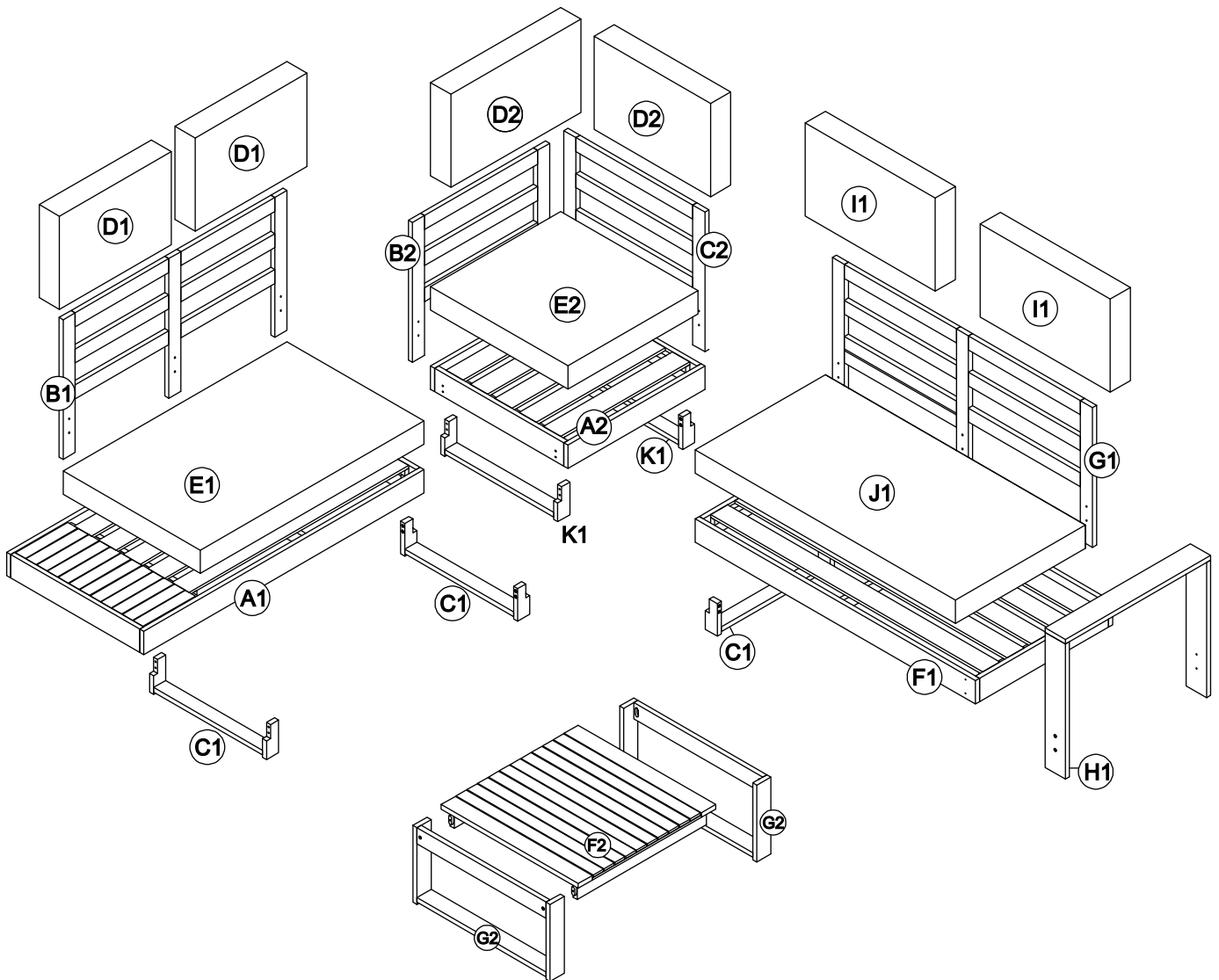

- Read instructions, cover to cover-



- Have 2 adults on hand for assembly-



- Do not assemble on flooring or carpet-



- Assemble on a clean non-marring surface (packing foam)-



- Save all packaging until finished-

Step 1:

① x 4

⑤ x 2

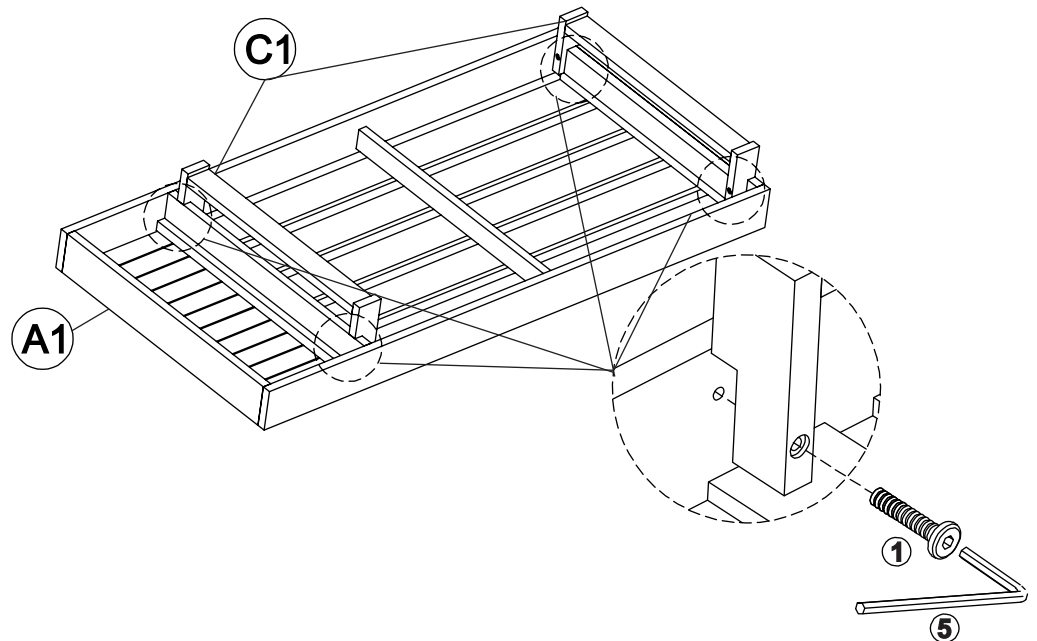

Unpack and place all parts on a clean, non-marring surface. Place the Left Chair Seat Panel (A1) facedown as shown above. With assistance from your adult partner, attach the Short Leg Panel (C1) to Left Seat Panel (A1) by using Bolts (①) with Allen Wrench(⑤) as shown above.

Do not fully tighten the Bolts at this time.

Step 2:

① x 6

② x 6

⑤ x 2

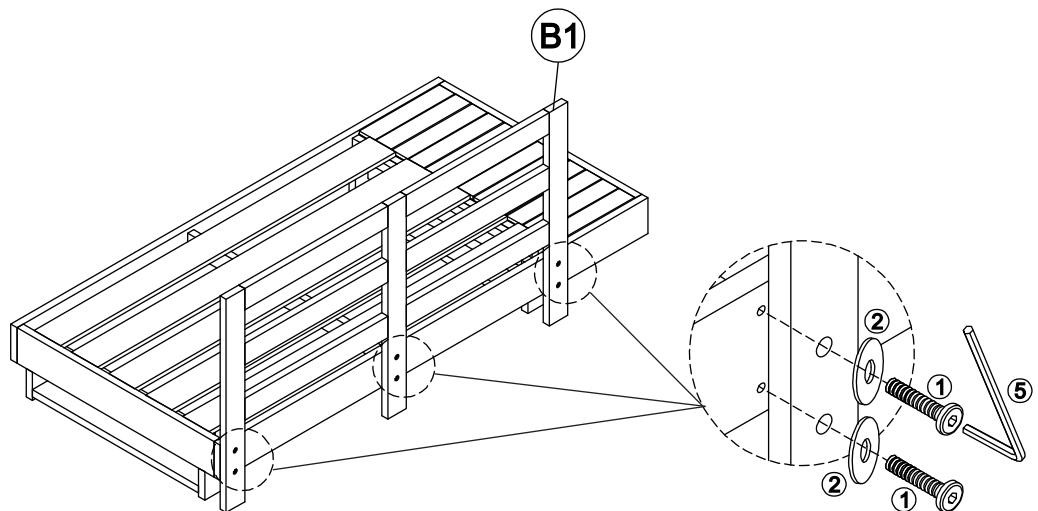

With assistance from your adult partner(s), attach the Left Chair Backrest Panel (B1) to the assembled frame in step 1 by using Bolts (①), Washers (②) and the Allen Wrench (⑤) as shown above.

Place the Chair onto a flat, level surface. Then EXERT pressure, floorwards onto the Chair with both hands.

This pressure will help the Chair reach full alignment at all joints.

In a sequential manner, gradually tighten all Bolts and Screws at all joints until evenly secured.

Inspect the Chair and make sure all parts are adequately connected.

Step 3:

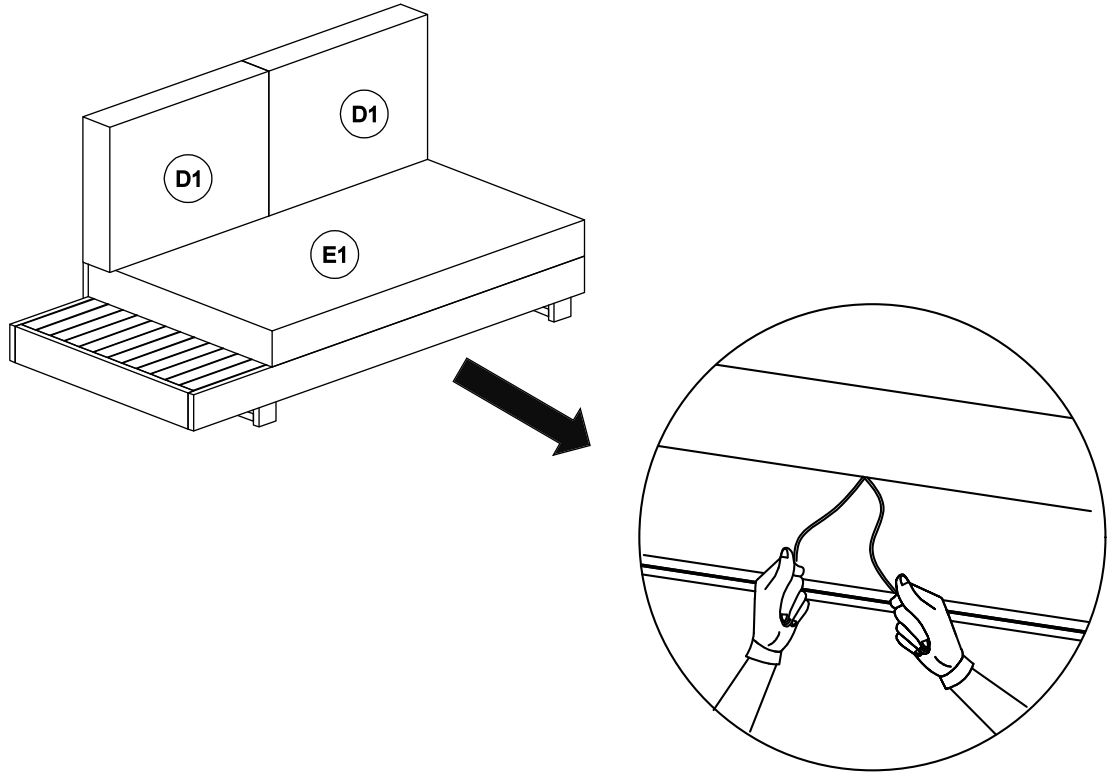

Place the Left Chair Seat Cushion (E1) and the Left Chair Back Cushions (D1) onto the Chair, and affix the straps around it as shown above. Your Chair is ready to be used.

This Chair can only be used on a flat, level surface.

Step 4:

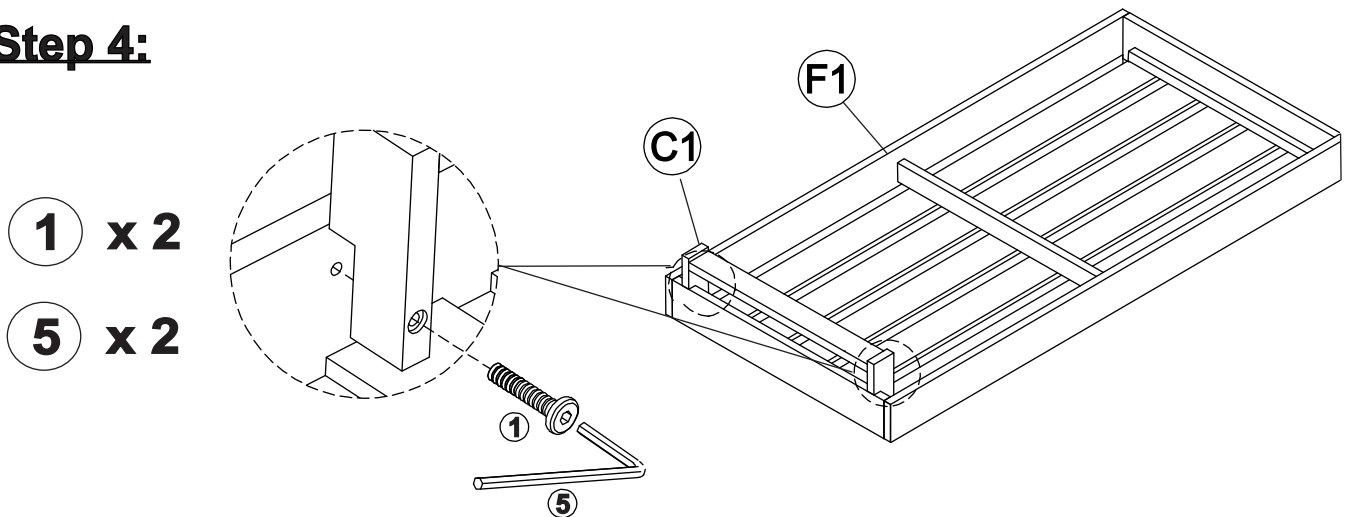

Place the Right Chair Seat Panel (F1) facedown as shown above. With assistance from your adult partner, attach the Short Leg Panel (C1) to Right Chair Seat Panel (F1) by using Bolts (①) with Allen Wrench(⑤) as shown above.

Do not fully tighten the Bolts at this time.

Step 5:

① x 4

⑤ x 2

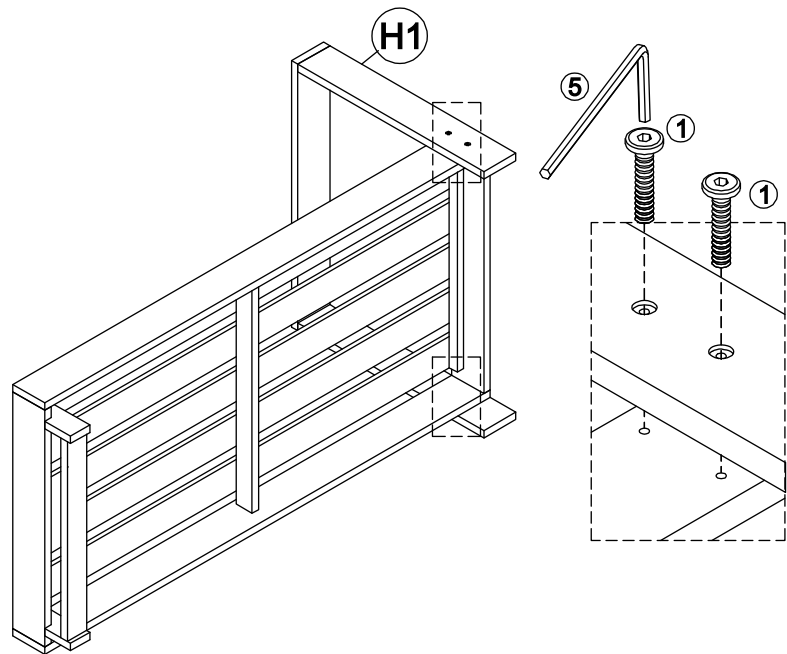

With assistance from your adult partner(s), attach the Right Chair Leg Panel With Arm (H1) to the assembled frame in step 4 by using Bolts (①) with the AllenWrench (⑤) as shown above.
Do not fully tighten the Bolts at this time.

Step 6:

① x 6

② x 6

⑤ x 2

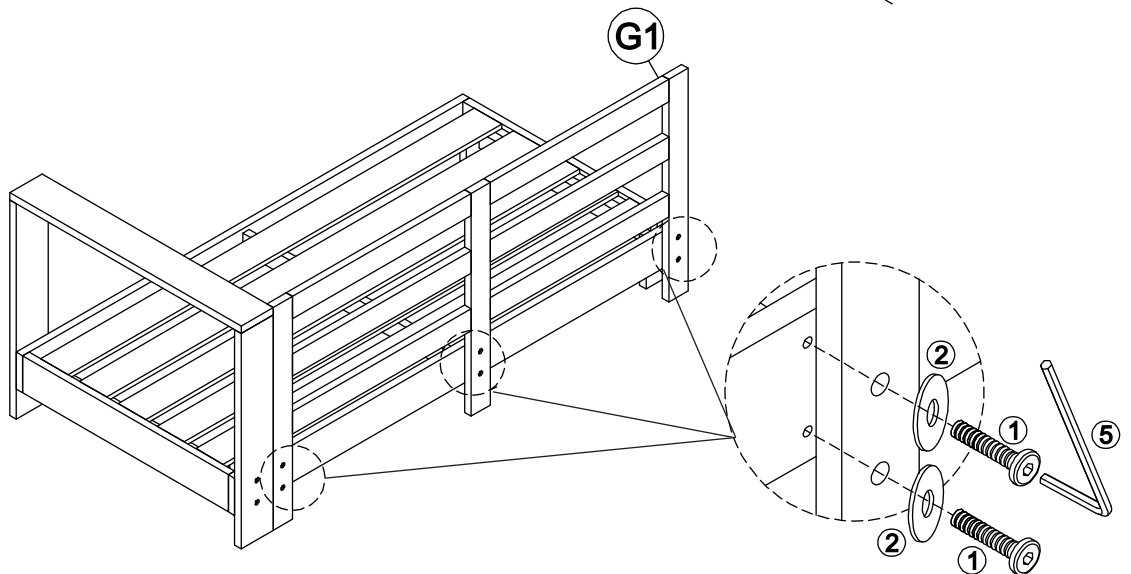

With assistance from your adult partner(s), attach the Right Chair Backrest Panel (G1) to the assembled frame in step 1 by using Bolts (①), Washers (②) and the Allen Wrench (⑤) as shown above.

Place the Chair onto a flat, level surface. Then EXERT pressure, floorwards onto the Chair with both hands.

This pressure will help the Chair reach full alignment at all joints.

In a sequential manner, gradually tighten all Bolts and Screws at all joints until evenly secured.

Inspect the Chair and make sure all parts are adequately connected.

Step 7:

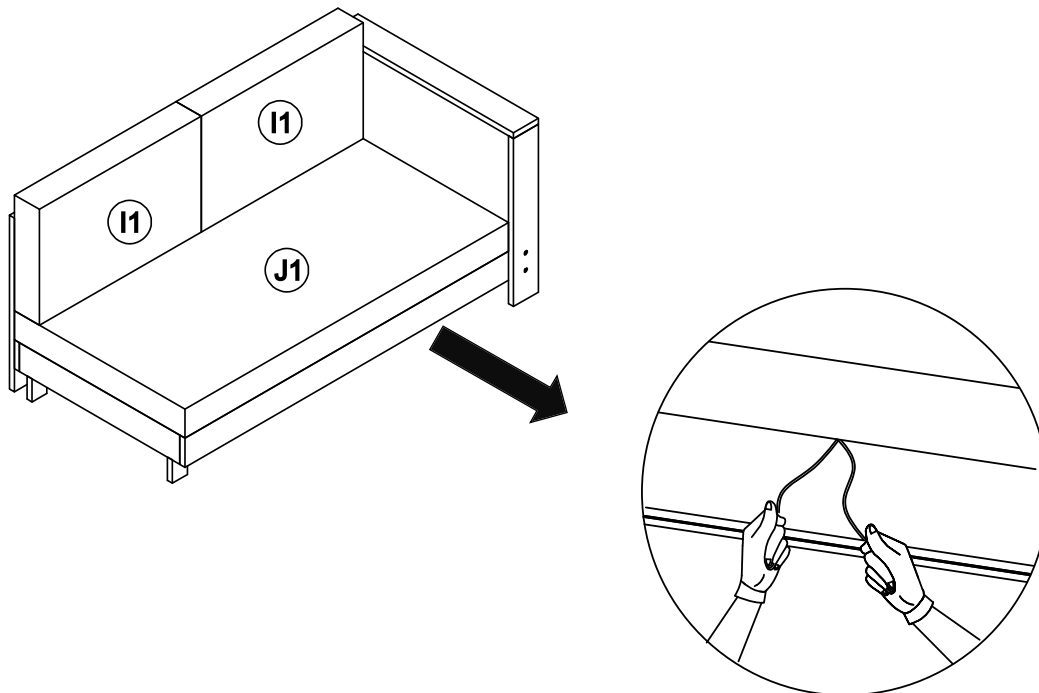

Place the Right Chair Seat Cushion (J1) and the Right Chair Back Cushions (I1) onto the Chair, and affix the straps around it as shown above.

Your Chair is ready to be used.

This Chair can only be used on a flat, level surface.

Step 8:

① x 4

⑤ x 2

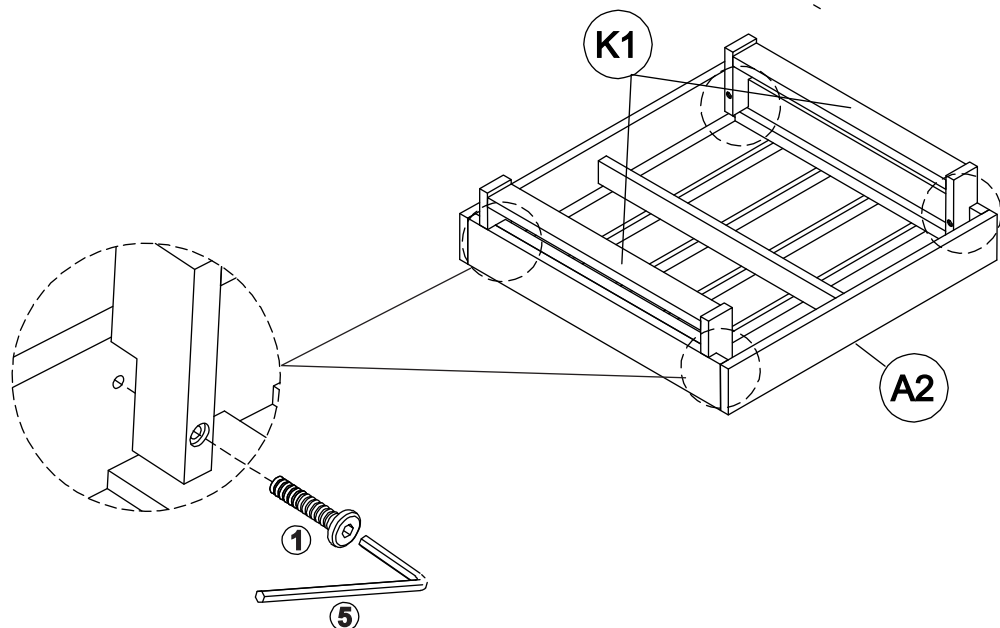

Place the Corner Seat Panel (A2) facedown as shown above.

With assistance from your adult partner, attach the Corner Leg Panel (K1) to Corner Seat Panel (A2) by using Bolts (①) with Allen Wrench (⑤) as shown above.

Do not fully tighten the Bolts at this time.

Step 9:

① x 8

② x 8

③ x 3

⑤ x 2

⑥ not provided

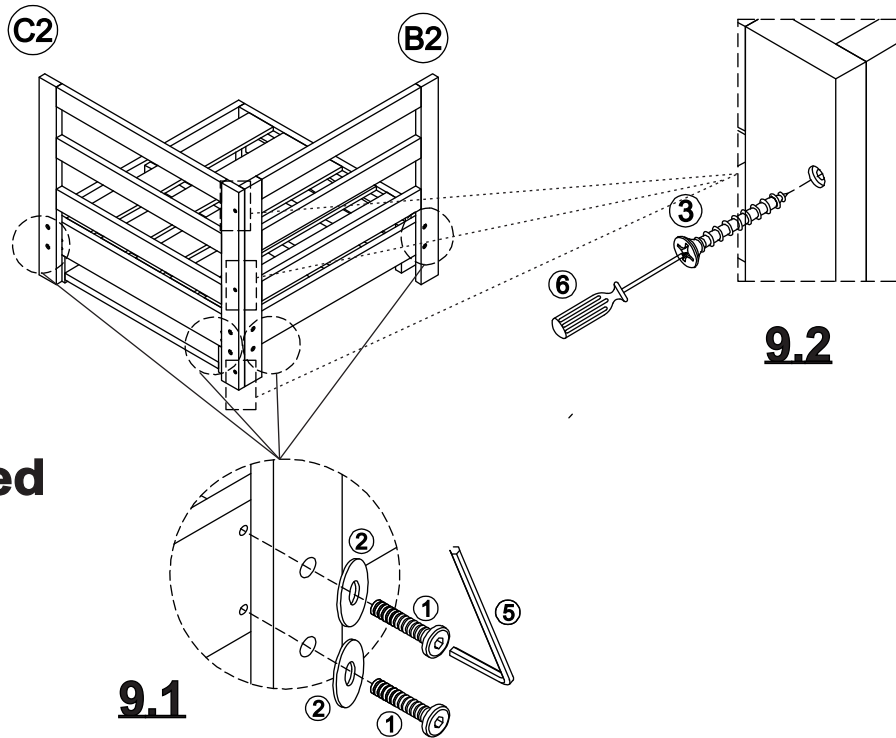

9.1 With assistance from your adult partner(s), attach the Corner Backrest Panel 1 (B2) and Corner Backrest Panel 2 (C2) to the assembled frame in step 8 by using Bolts (①), Washers (②), with the Allen Wrench (⑤) as shown above.

9.2 Secure the he Corner Backrest Panel 1 (B2) and Corner Backrest Panel 2 (C2) by using Screws (③) and Screw driver (⑥) as shown above. Place the Chair onto a flat, level surface. Then EXERT pressure, floorwards onto the Chair with both hands.

This pressure will help the Chair reach full alignment at all joints.

In a sequential manner, gradually tighten all Bolts and Screws at all joints until evenly secured.

Inspect the Chair and make sure all parts are adequately connected.

Step 10:

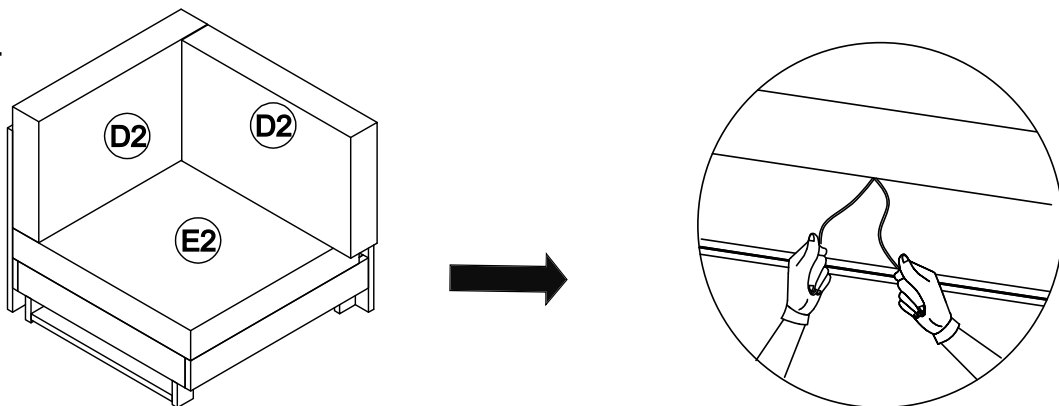

Place the Corner Seat Cushion (E2) and the Corner Back Cushions (D2) onto the Chair, and affix the straps around it as shown above.

Your Chair is ready to be used.

This Chair can only be used on a flat, level surface.

Step 11:

④ x 4

⑤ x 2

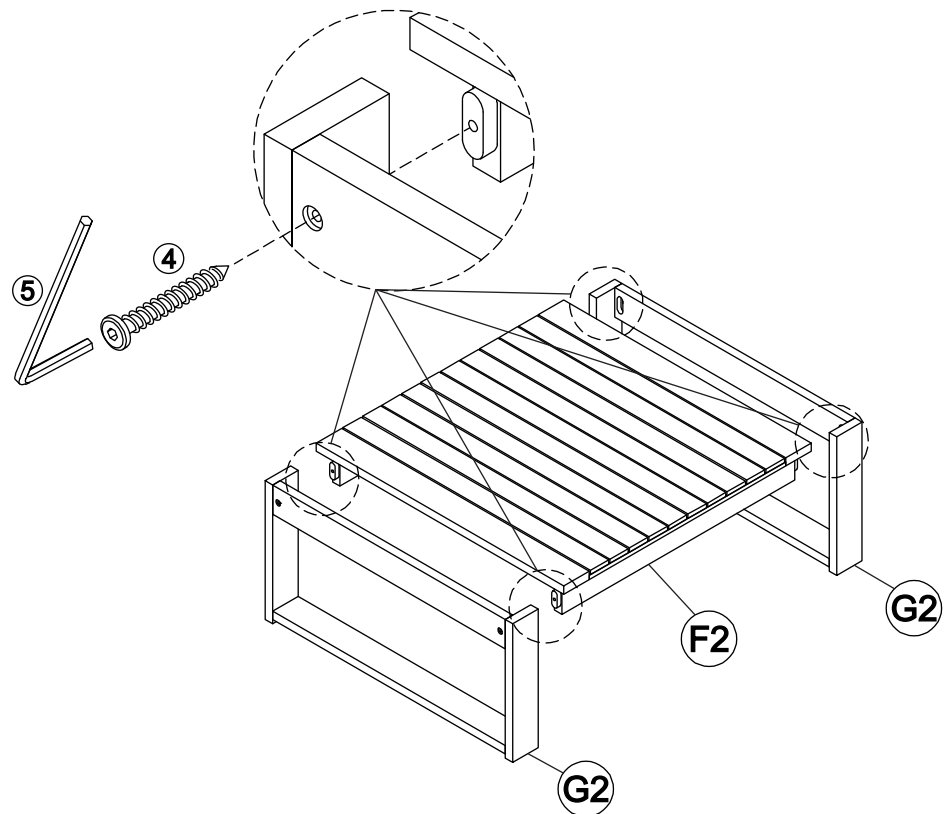

With the help from your adult partner, attach the Table Leg Panel (G2) to the Table Top (F2) using Screws (④), and the Allen Wrench (⑤) as pictured.

Do not fully tighten the Srews at this time.

Step 12:

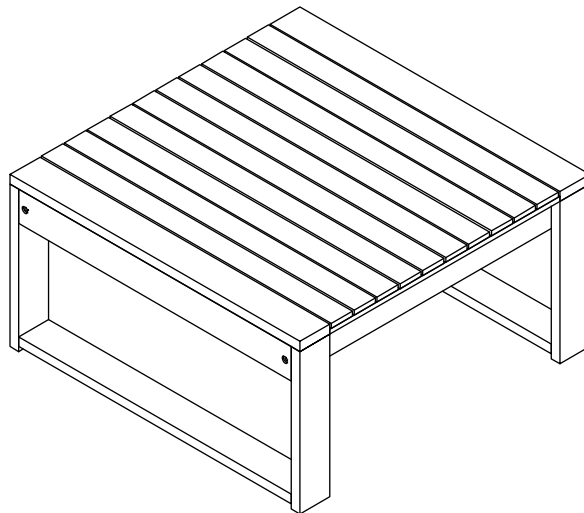

Place the Table on a flat, level surface to make sure it is balance

CAUTION: When tightening these screws, tighten sequentially.

DO NOT tighten any screw fully and then towards the next one. This would cause the frame to warp.

WARNING ! IF THE TABLE IS NOT STABLE , IT COULD LEAD TO DAMAGING THE PRODUCT.

Your Table is ready to be used.

Caution: This Table can only be used on a flat, level surface.