

ASSEMBLY INSTRUCTION

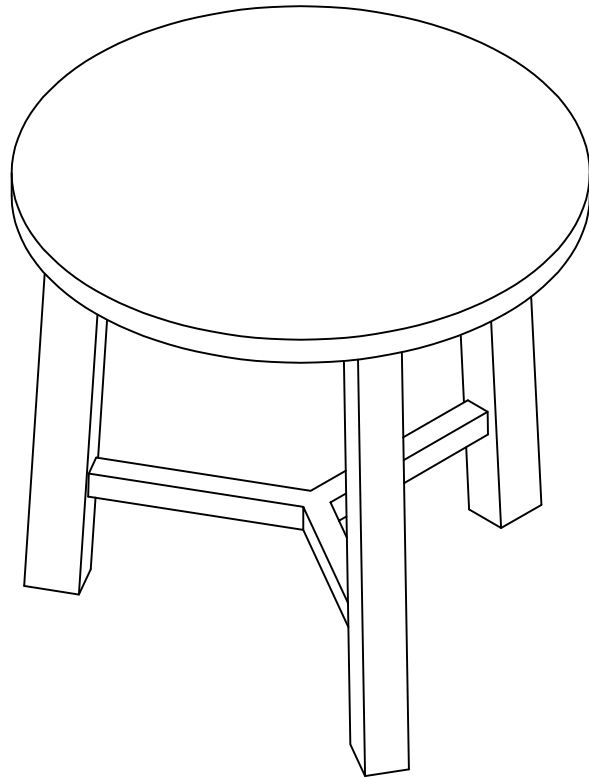

REPLACEMENT PARTS

Please do not contact the company purchased from as we can help you faster.
Order replacement parts and hardware

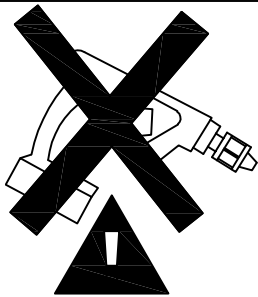

. Use of power tool to assemble this product will invalidate any claim and damage this product making it unsafe !!!
. Please assemble on a clean soft surface to avoid damage.

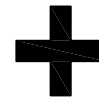
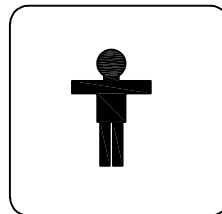

Tools Required

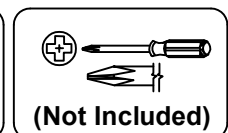
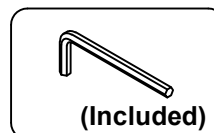

Part list - 20" Dia. End Table

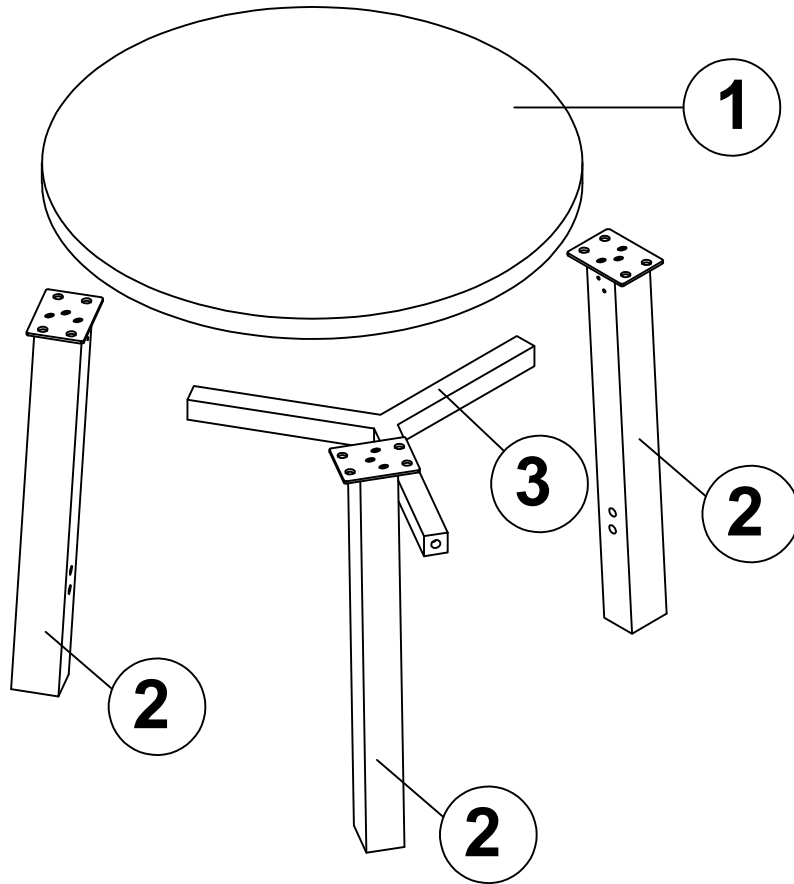

Identifying the hardware-Identify the hardware using the illustrations below

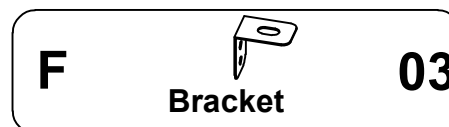
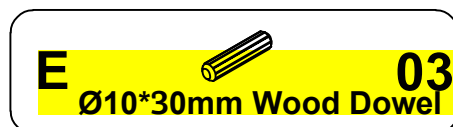
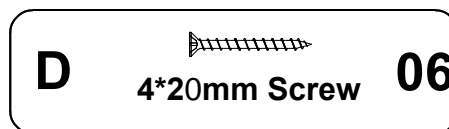
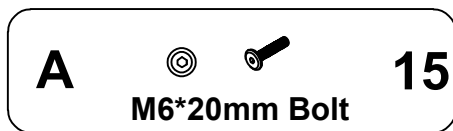

Step 01

D  **06**

F  **03**
Bracket

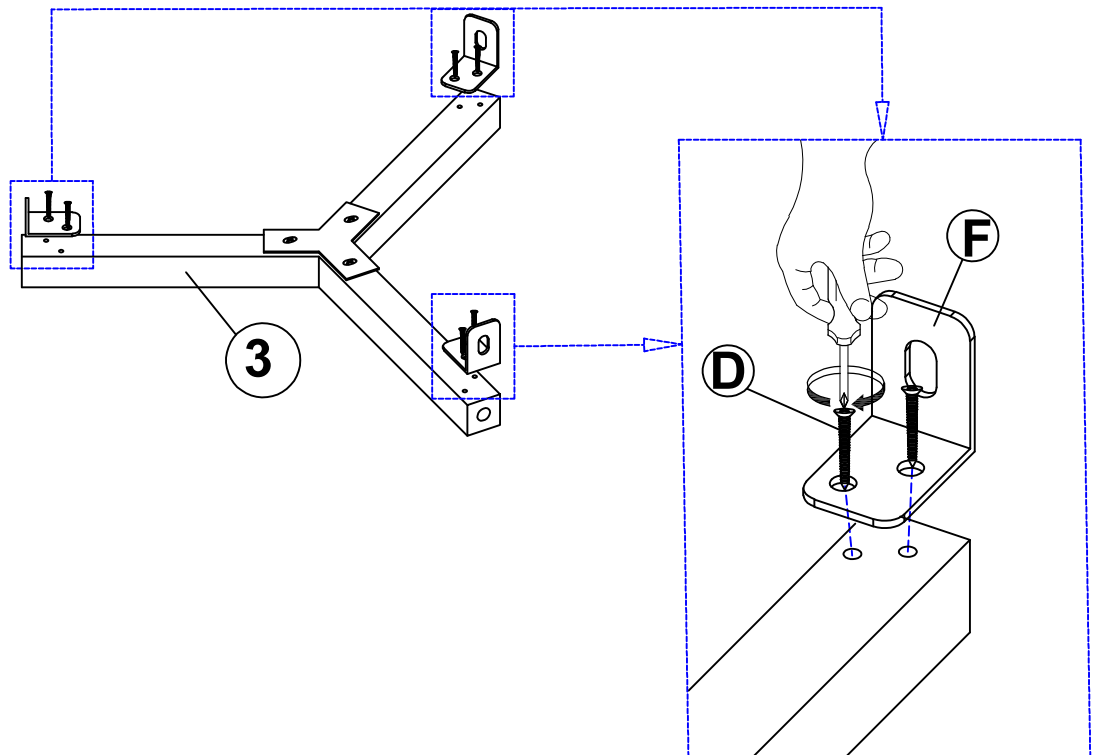

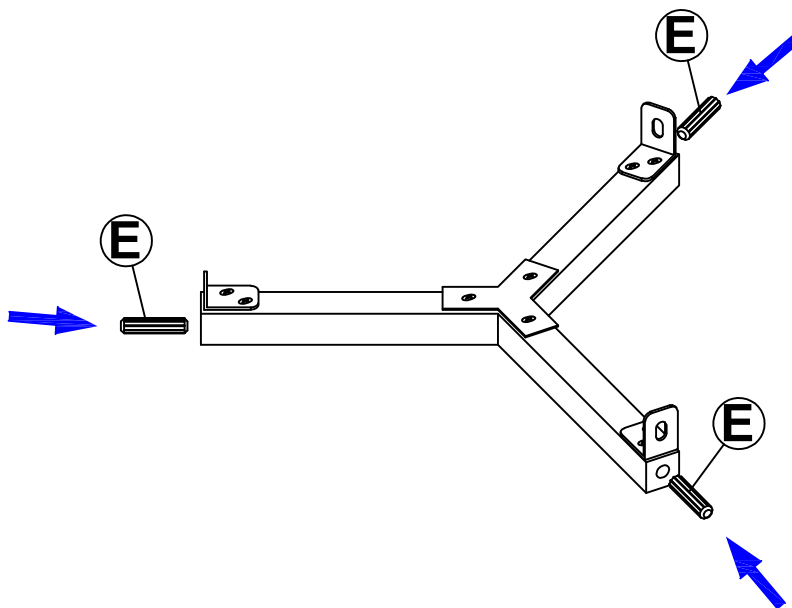

Step 02

E  **03**
Ø10*30mm Wood Dowel



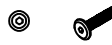

Step 03

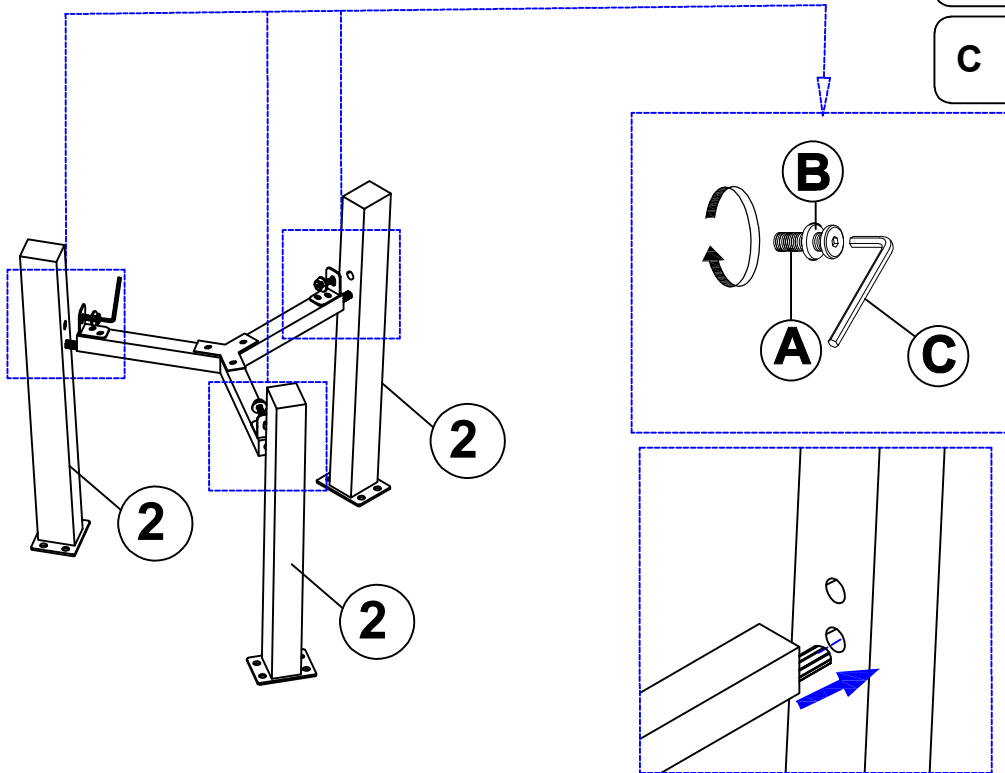
- A**  **03**
M6*20mm Bolt
- B**  **03**
M6 Washer
- C**  **01**
Allen Key



Note: Do not tighten bolts firmly at this time

Step 04

- A**  **12**
M6*20mm Bolt
- B**  **12**
M6 Washer
- C**  **01**
Allen Key

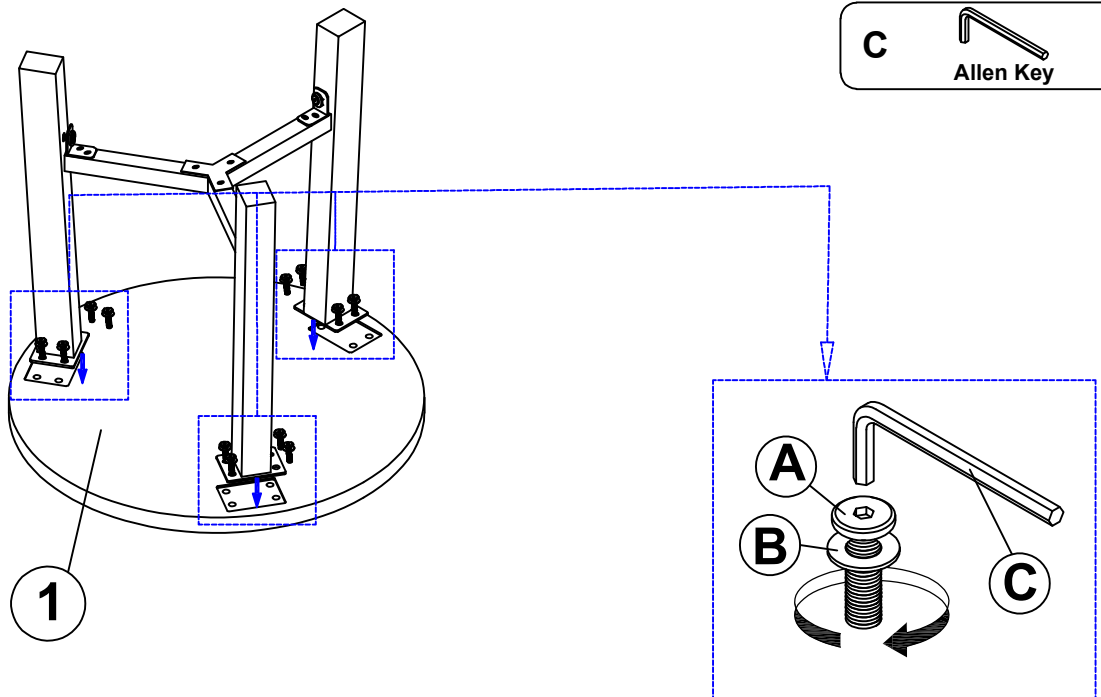

Note: Tighten all bolts at this time

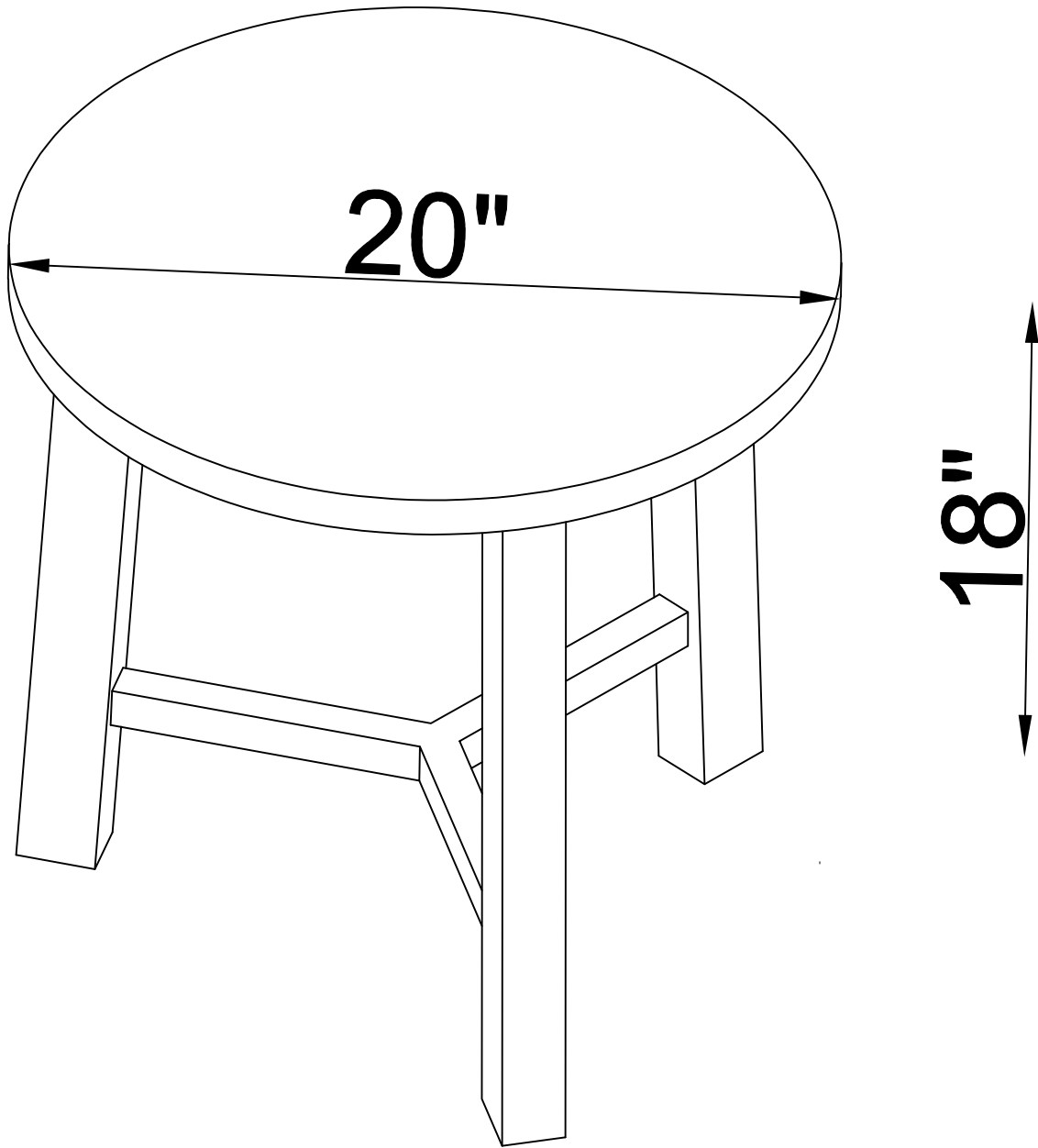

20" Diameter End Table