

ASSEMBLY INSTRUCTION

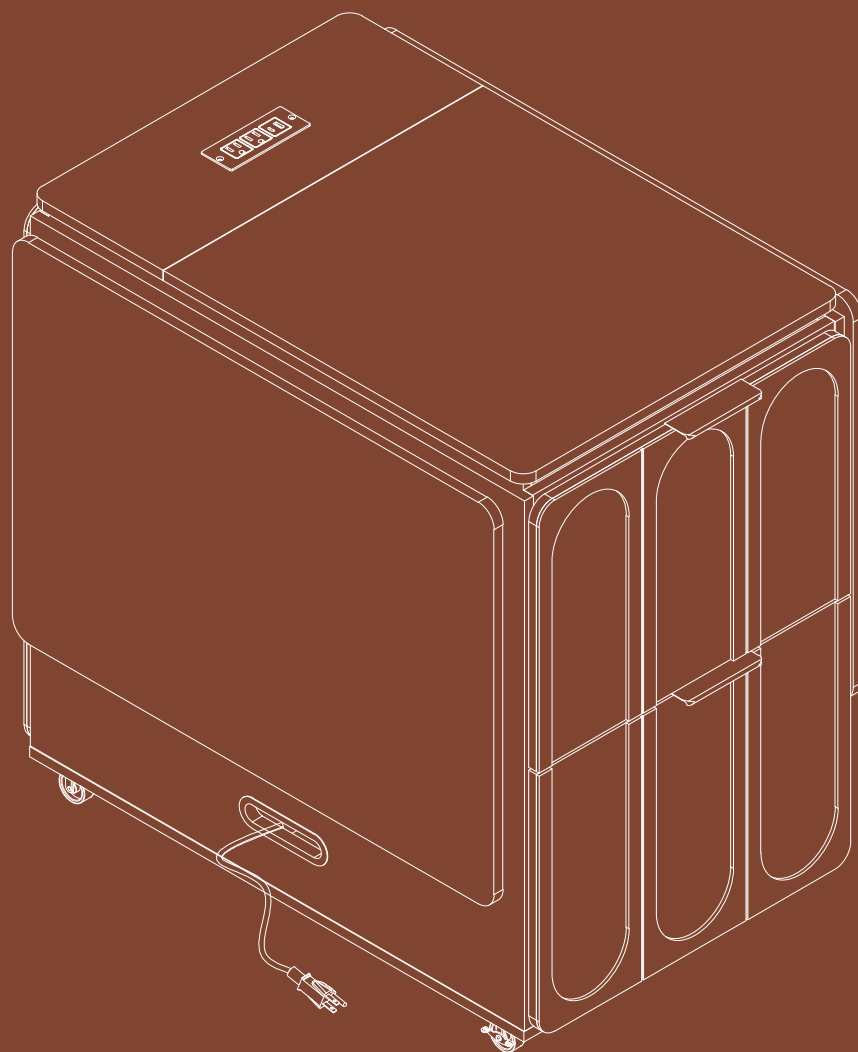

File Cabinet

CATALOGUE

Precautions	01
Parts List	02-03
Hardware List	04-05
Tool List	06
Assembling Process	07-37

INTRODUCTION

Thank you for purchasing our products. Please read the instructions carefully before installation and keep it in a safe place for future reference. If you need any assistance or support, please feel free to contact our customer support team.

PRECAUTIONS

1. There are many components and accessories in the package. Each component and accessory is labeled with a letter or a number, check carefully before using any of them. Keep them away from children to prevent accidents.
 2. Please install the product on a clean and soft underlay (such as carpet or cardboard) to avoid scratching or damaging the surface of the product.
 3. The main components of the product is relatively heavy. Please pay attention to safety during installation.
 4. The product is not stable during installation. Please do not move it randomly before it is completely installed.
 5. If you have any questions during installation, please contact the customer service in time.
- * **Please be sure to follow the installation steps in the manual to avoid unnecessary losses caused by improper installation.**
 - * **If you need further assistance, please contact the customer service online.**

Parts List

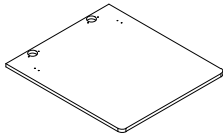
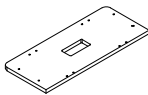
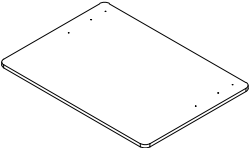
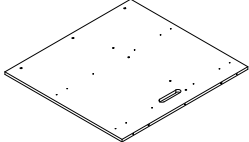
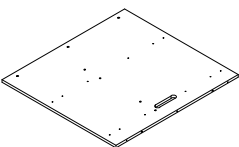
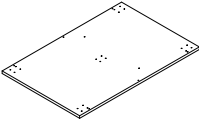
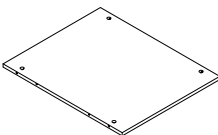
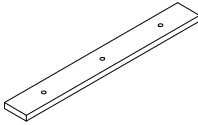
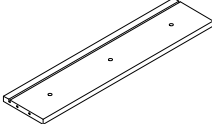
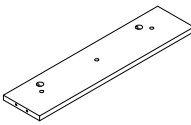

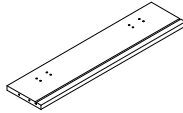
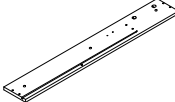
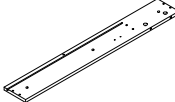
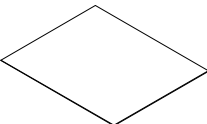
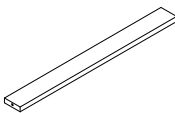
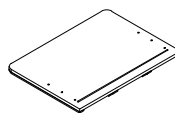
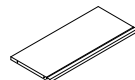
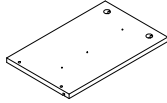
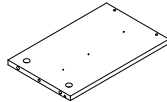
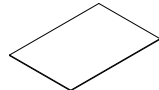

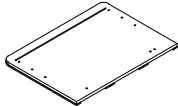
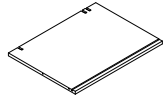

ID	Parts	QTY
1		1
2		1
3		2
4		1
5		1
6		1
7		1
8		2
9		1
10		1



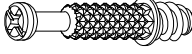

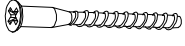
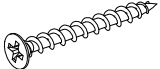
ID	Parts	QTY
11		1
12		1
13		1
14		1
15		1
16		2
17		2
18		4
19		4
20		4

Parts List

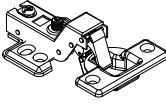
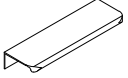

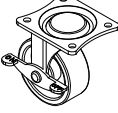
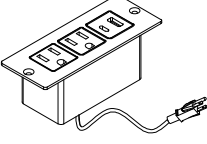
ID	Parts	QTY
21		2
22		2

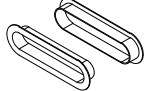
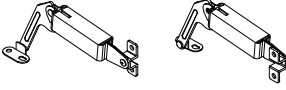
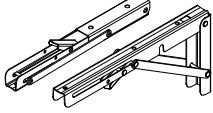
Hardware List

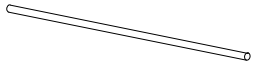

ID	Parts	QTY
A	 Ø6*33.5mm	28+2
B	 Ø15*9.5mm	28+2
C	 Ø6*30mm	30+3
D	 Ø5*50mm	22+2
E	 Ø4*38mm	16+1
F	 Ø4*14mm	12+1
G	 Ø3.5*12mm	10
H	 Ø3.5*12mm	68+6
I		2
J		4

ID	Parts	QTY
K		3
L		2
M		1
N		36
O		2
P	 P1x1 P2x1	1
Q		4
R	 Ø4*14mm	20+2
S	 M6*20mm	12+1

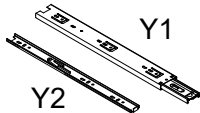
Hardware List

ID	Parts	QTY
<p>U</p>		<p>4</p>
<p>X</p>	 <p>M6*15mm</p>	<p>8</p>
<p>Y</p>	 <p>Y1</p> <p>Y2</p>	<p>8</p>

Tool List

ID	Parts	QTY
T	 M4	1
V		1

Required Tools (Not Included)

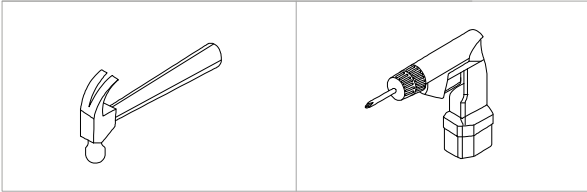

Wall mounting only

These tools are not required for product assembly.

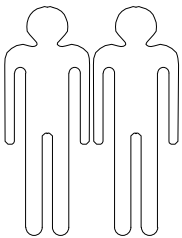

Multi-person installation

Parts List

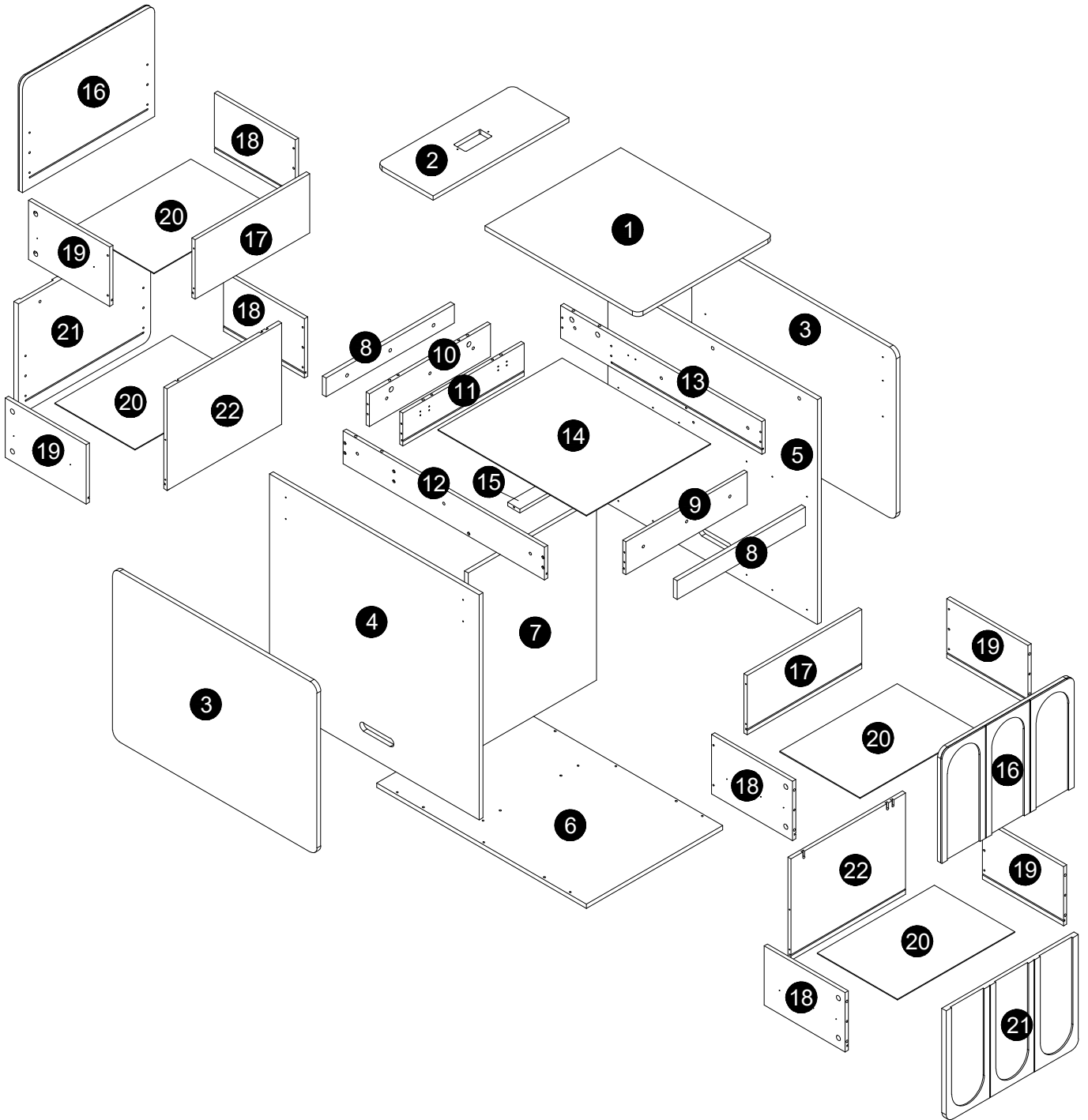

STEP 1

INSTALLATION STEPS

Press the plastic part in the indicated direction to separate drawer runner **Y1** and **Y2** before assembling.

REMARK:

Please grip the **Y1** part while sliding the **Y2** part.

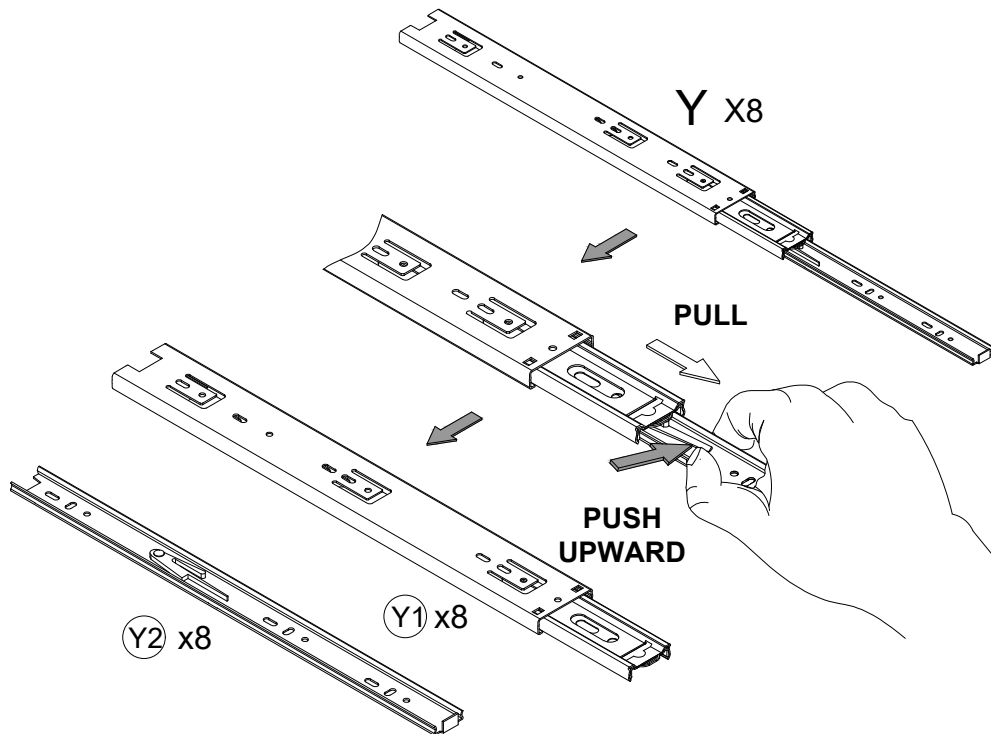

STEP 2

 **H** X24

 **Y1** X8

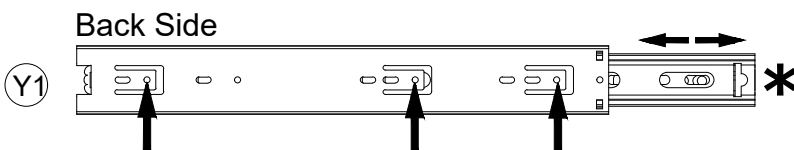
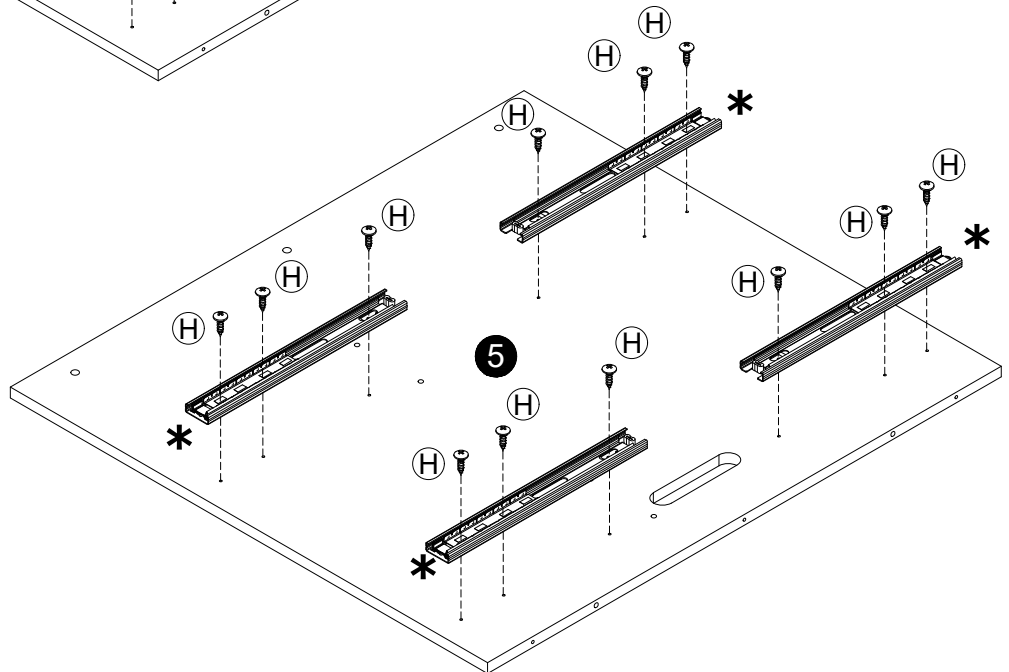
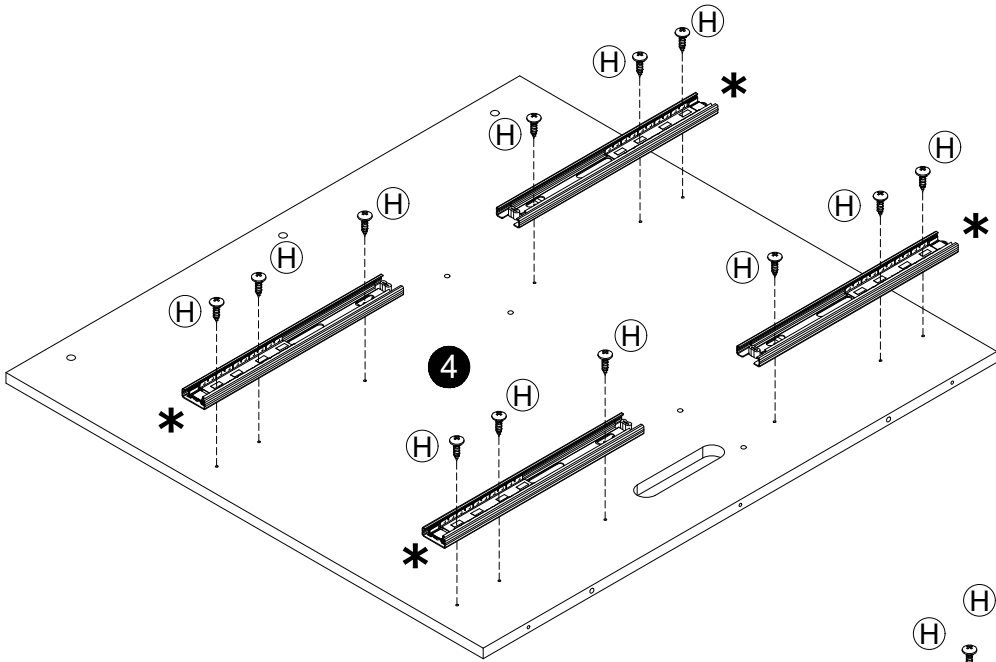

Make sure to insert screws in the correct opening.

STEP 3

 **A** X4

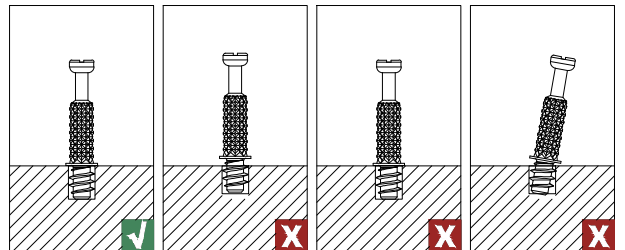
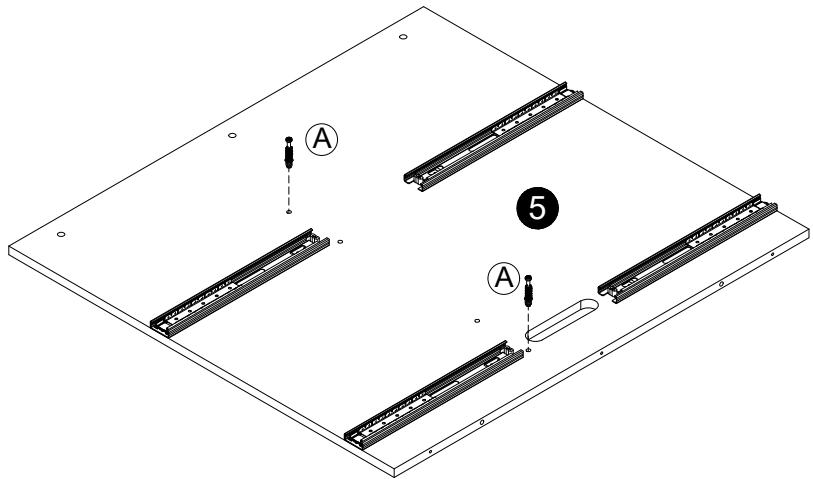
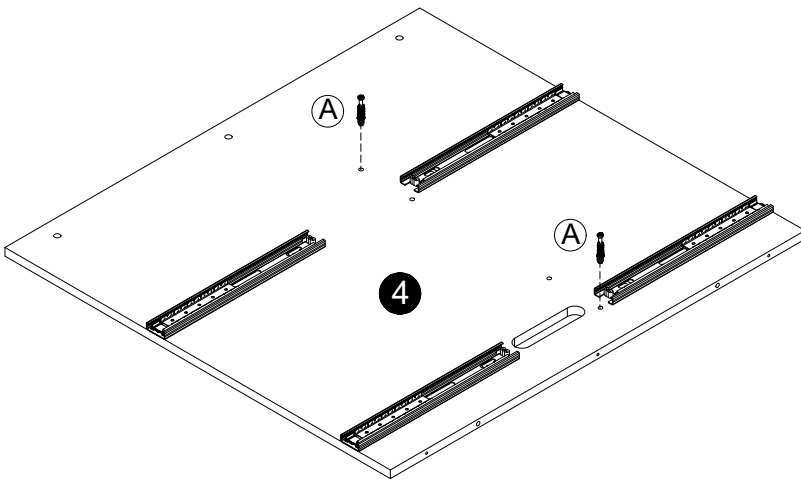

Install the screw correctly to secure the screw.

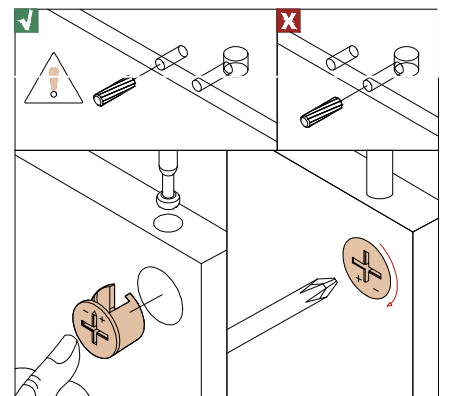
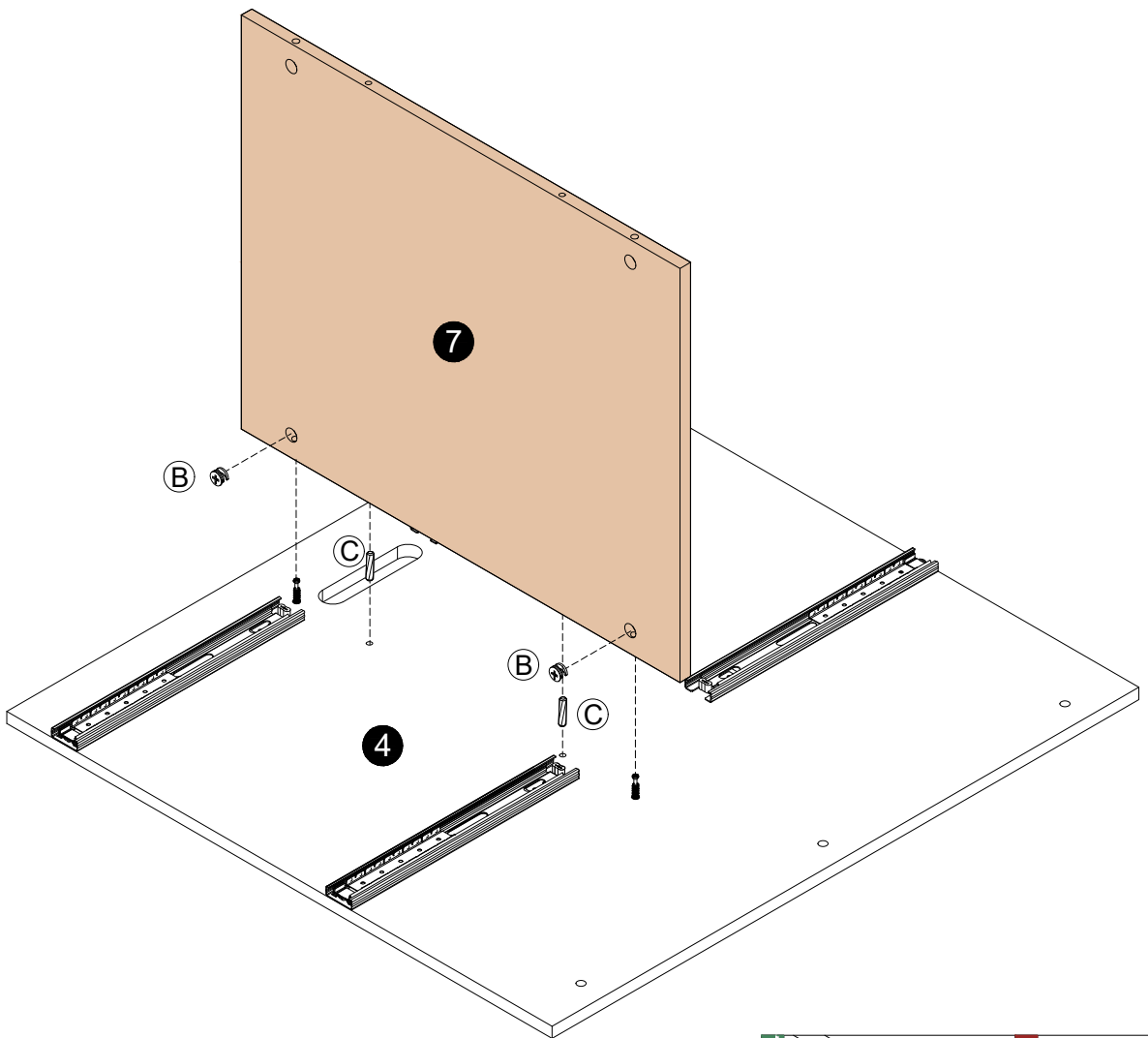
STEP 4**B** X2**C** X2

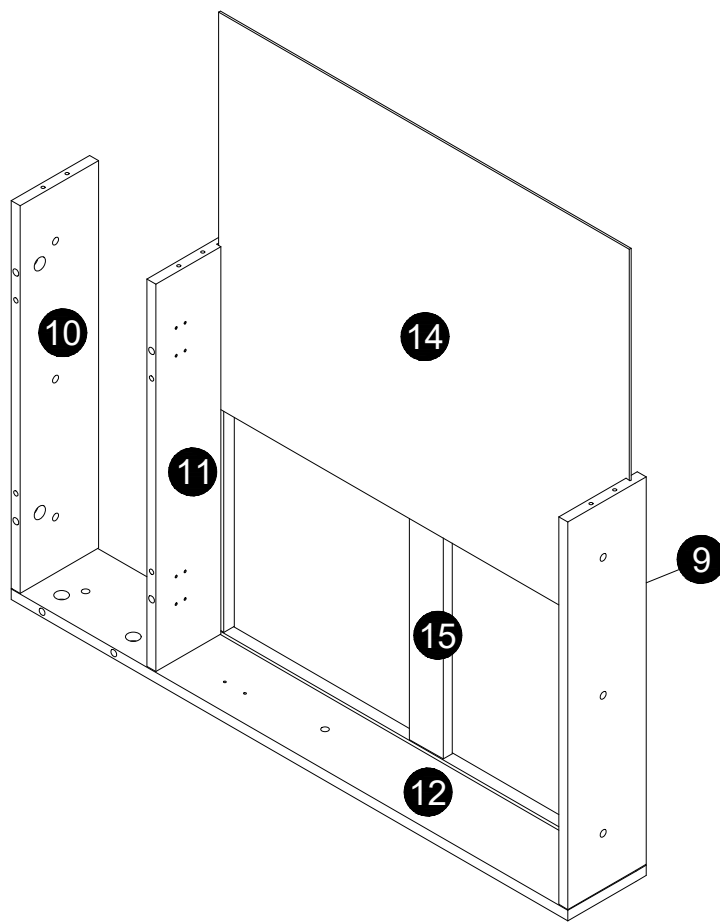

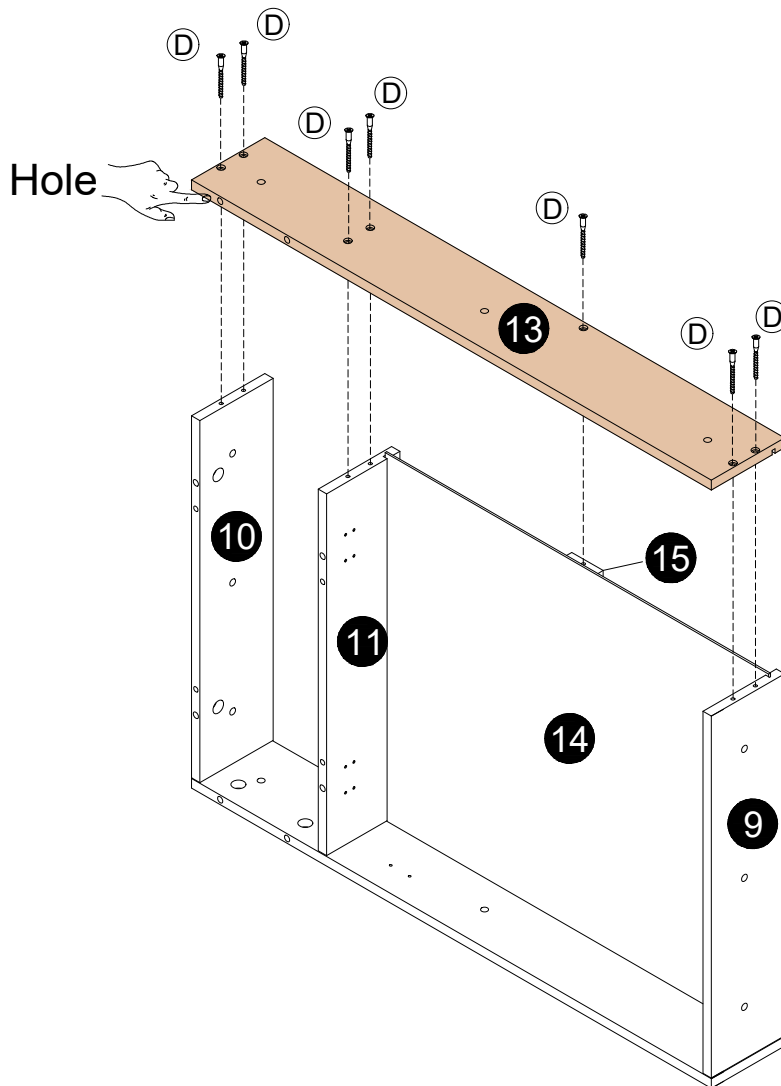
STEP 6

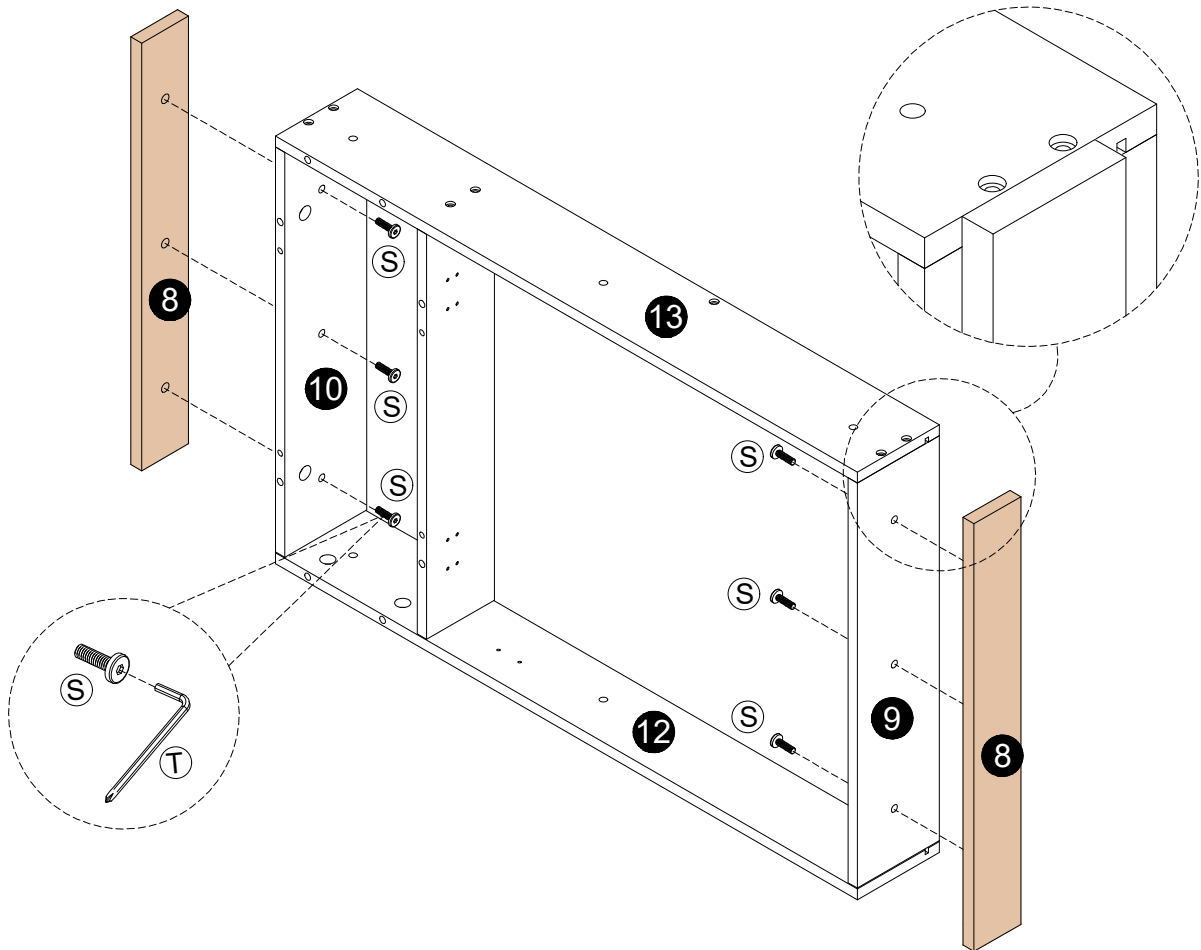
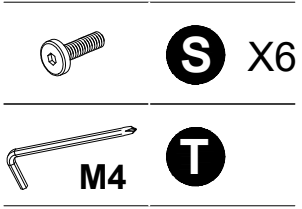
STEP 7

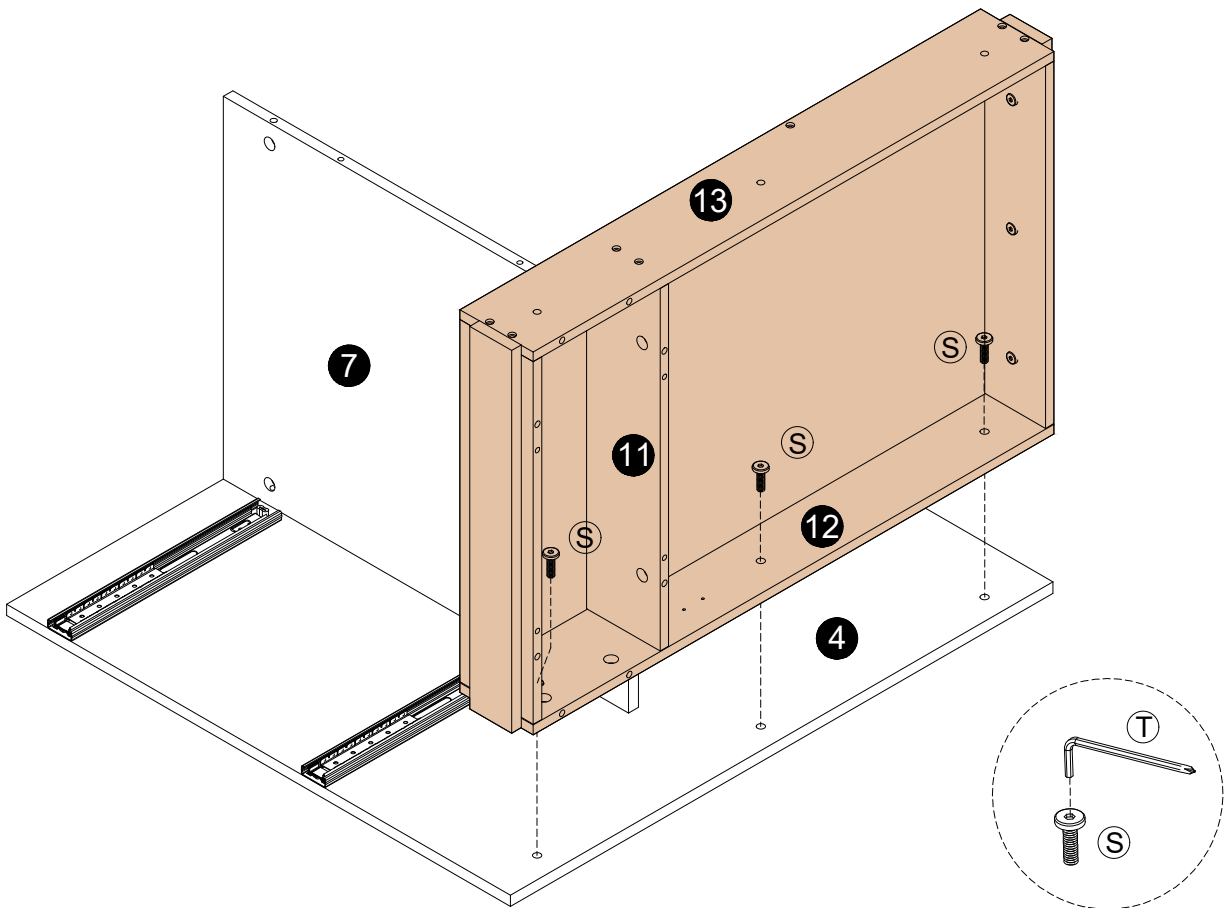
STEP 8

STEP 9

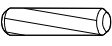
STEP 10

-  **B** X2
-  **C** X2
-  **S** X3
-  **T** M4

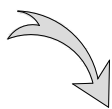
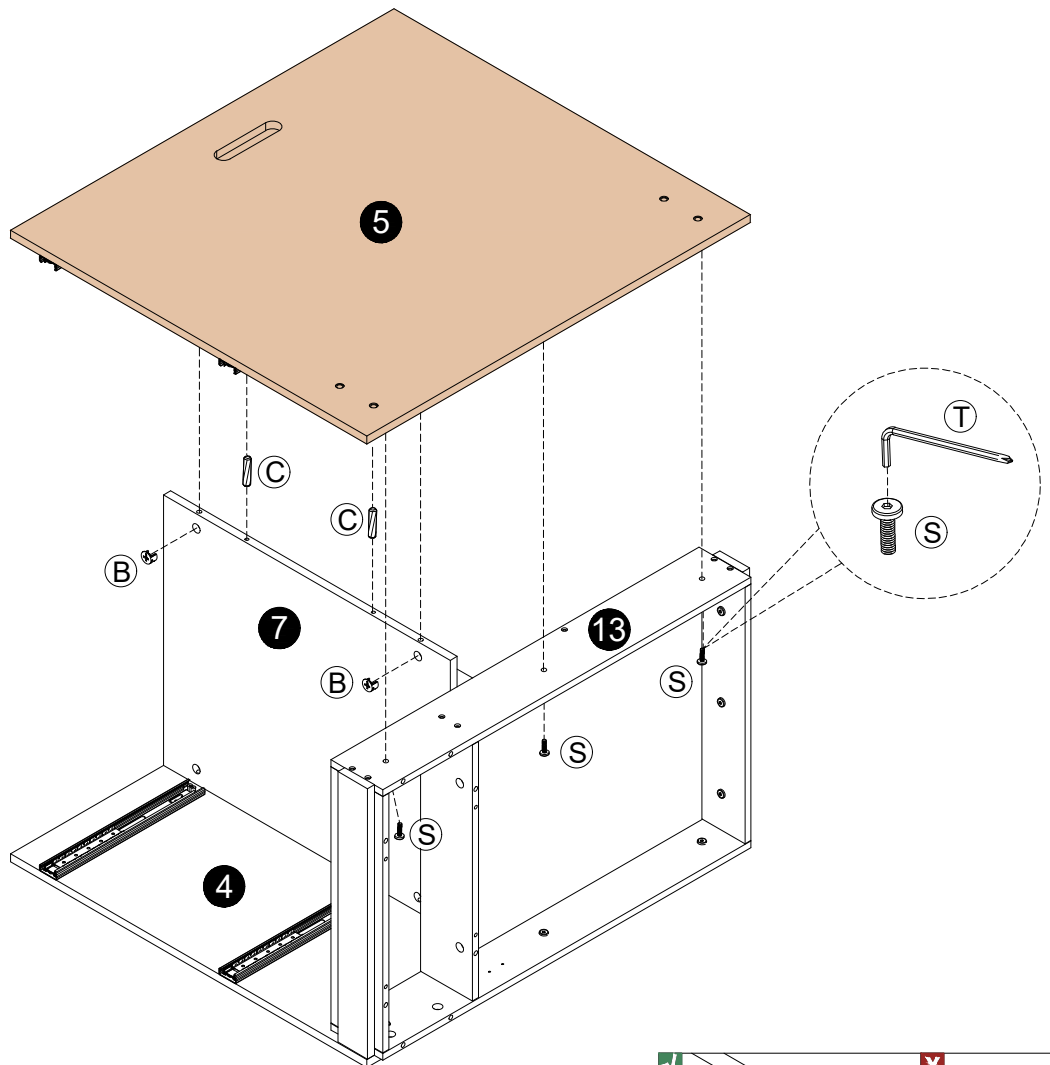

After this step is assembled,
flip it 90 degrees(to next step)

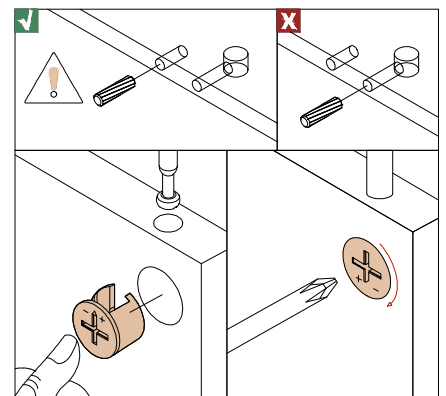



STEP 11

 **D** X8

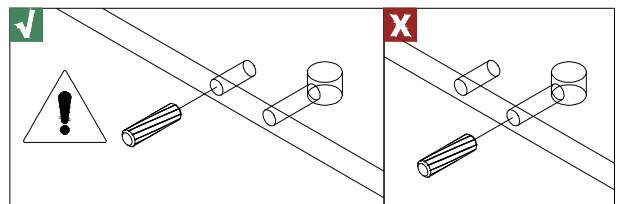
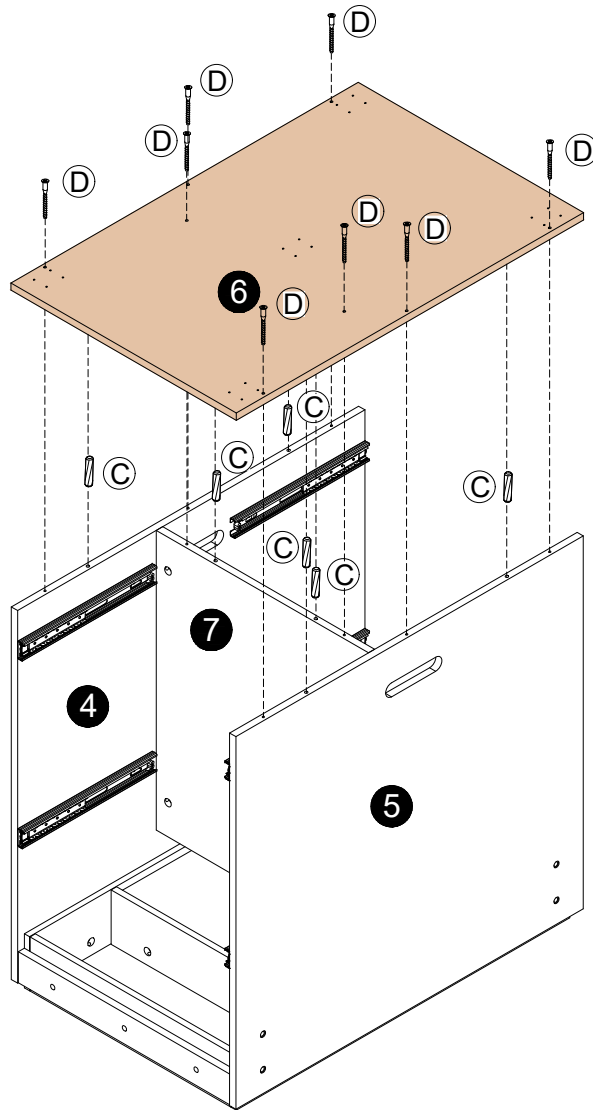
 **C** X6



STEP 12

- 
K X3
- 
L X2
- 
H X20

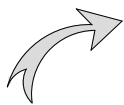
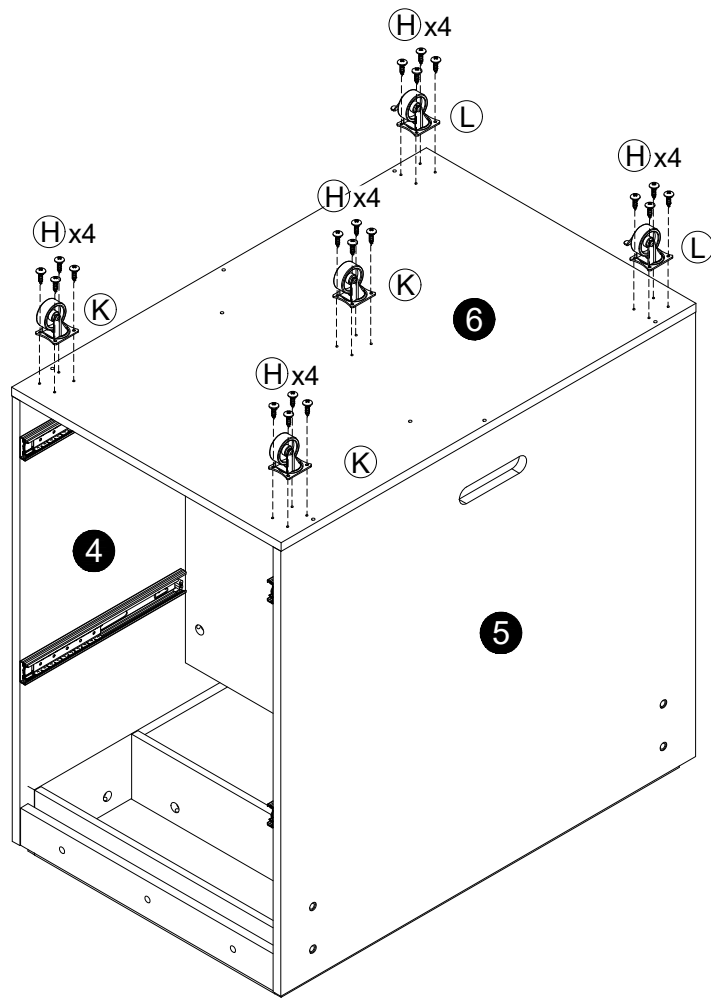

After this step is assembled,
flip it 90 degrees(to next step)

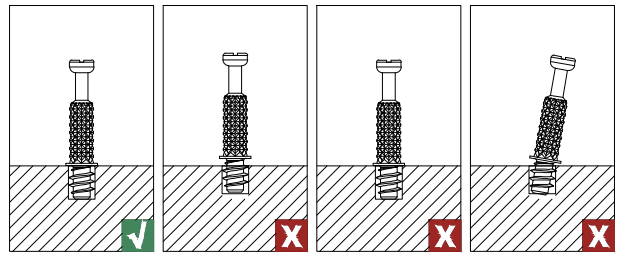
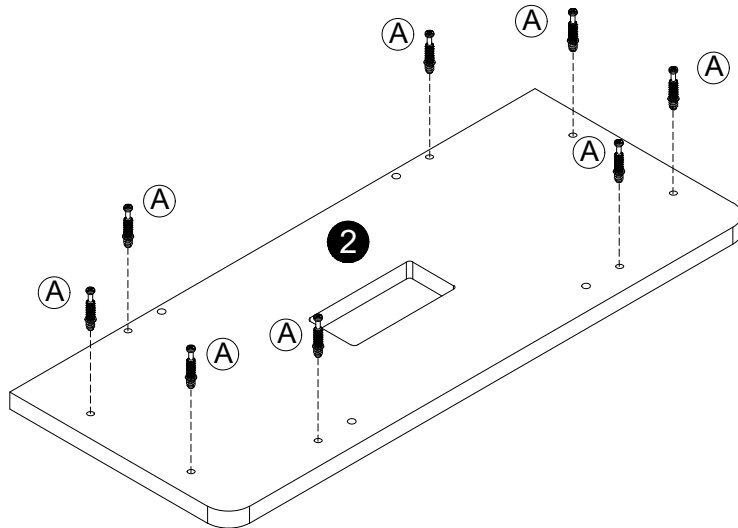
STEP 13

Install the screw
correctly to secure
the screw.

STEP 14

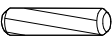
- 
B X8
- 
C X4

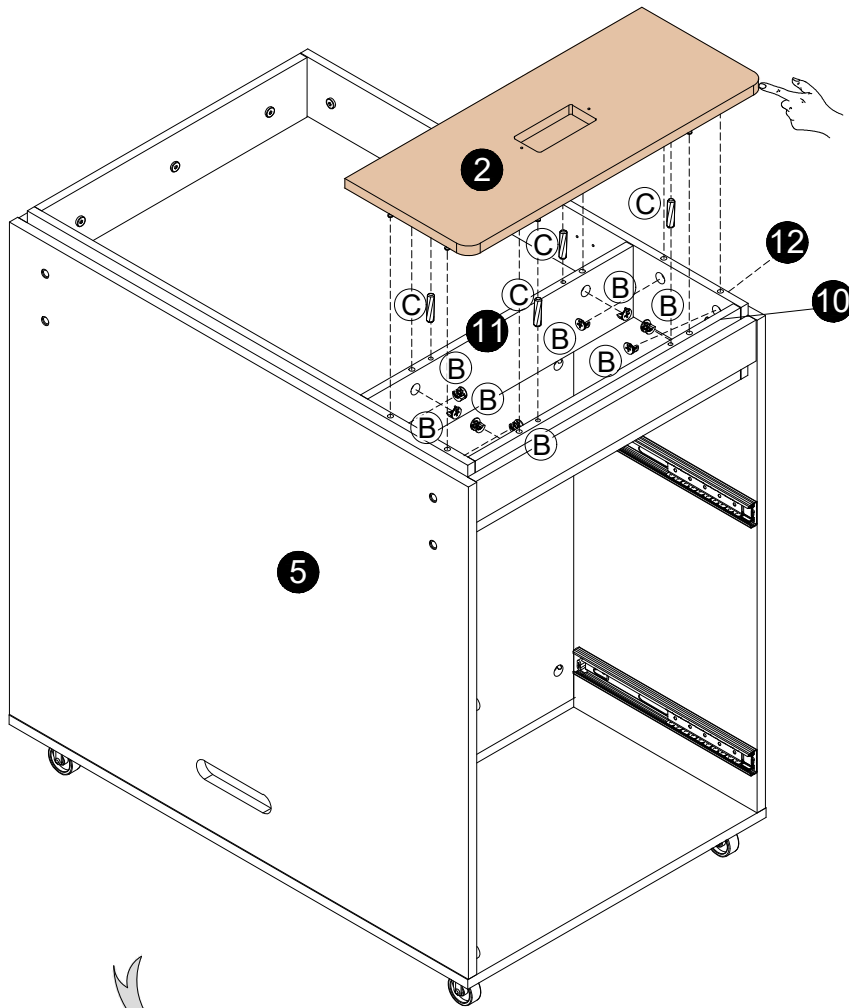

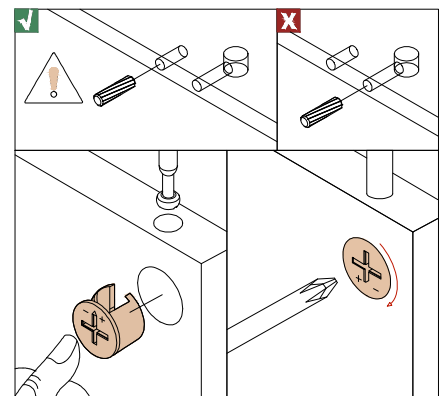

 TURN

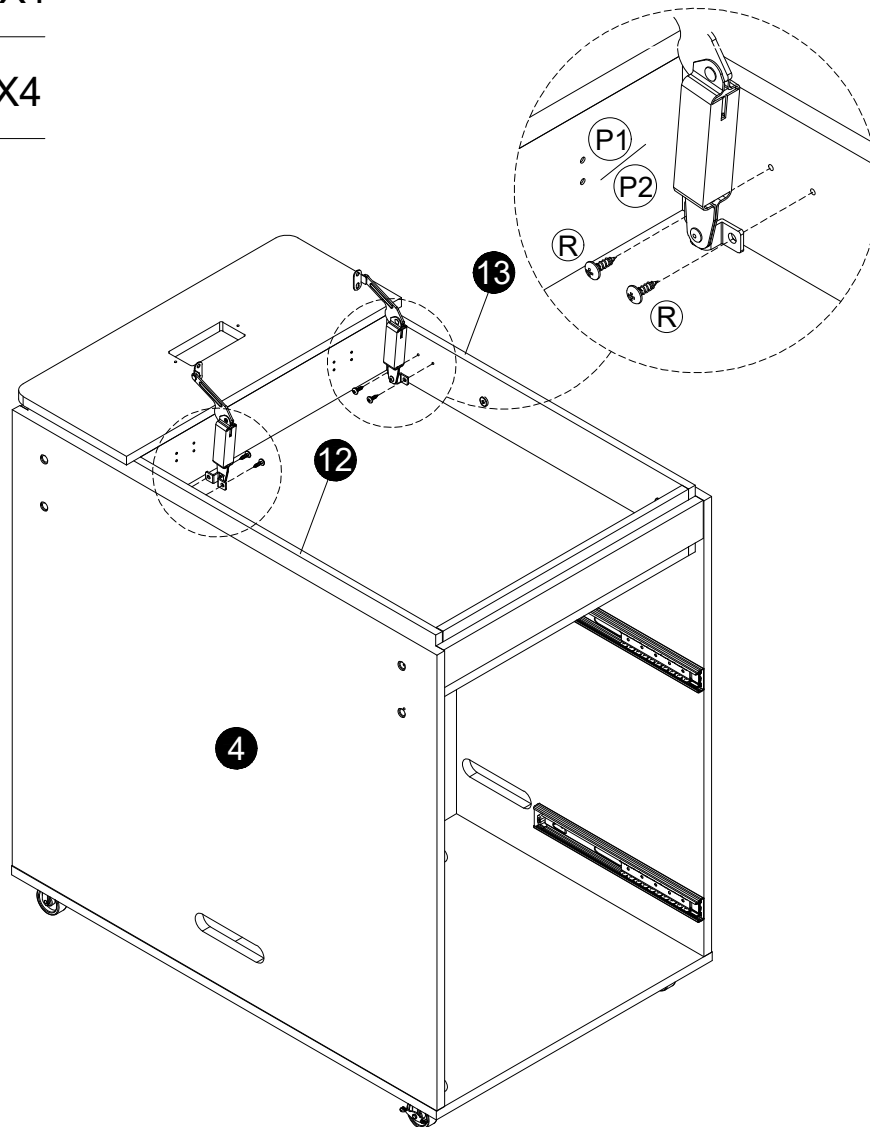

STEP 15

**P1** X1**P2** X1**R** X4

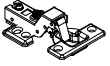
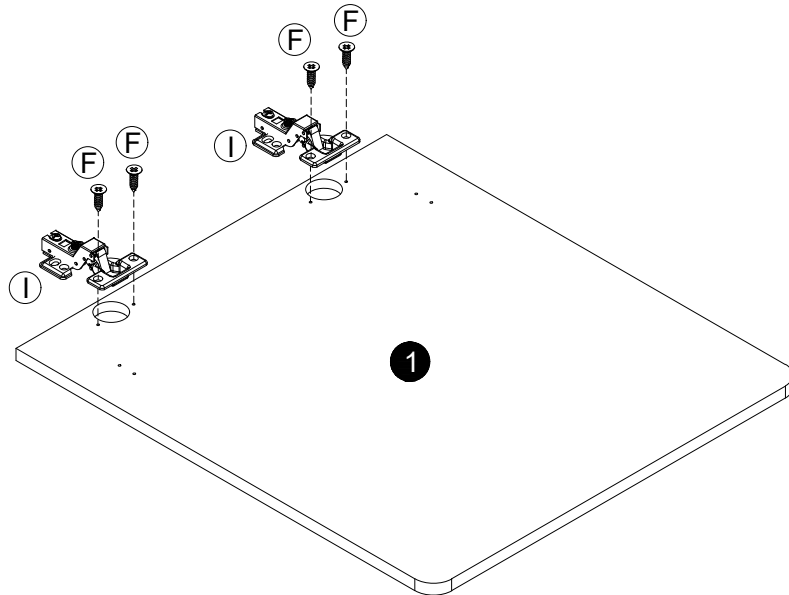
STEP 16

**F** X4**I** X2

STEP 17

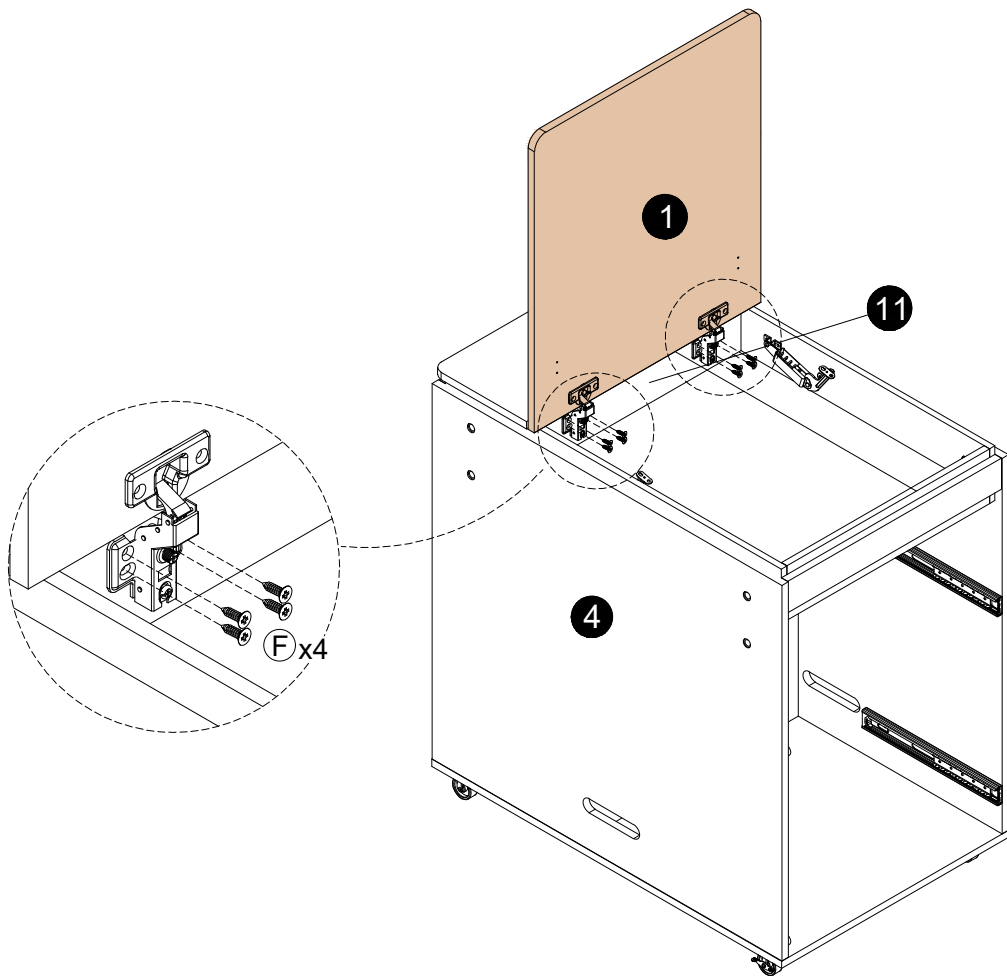
**F** X8

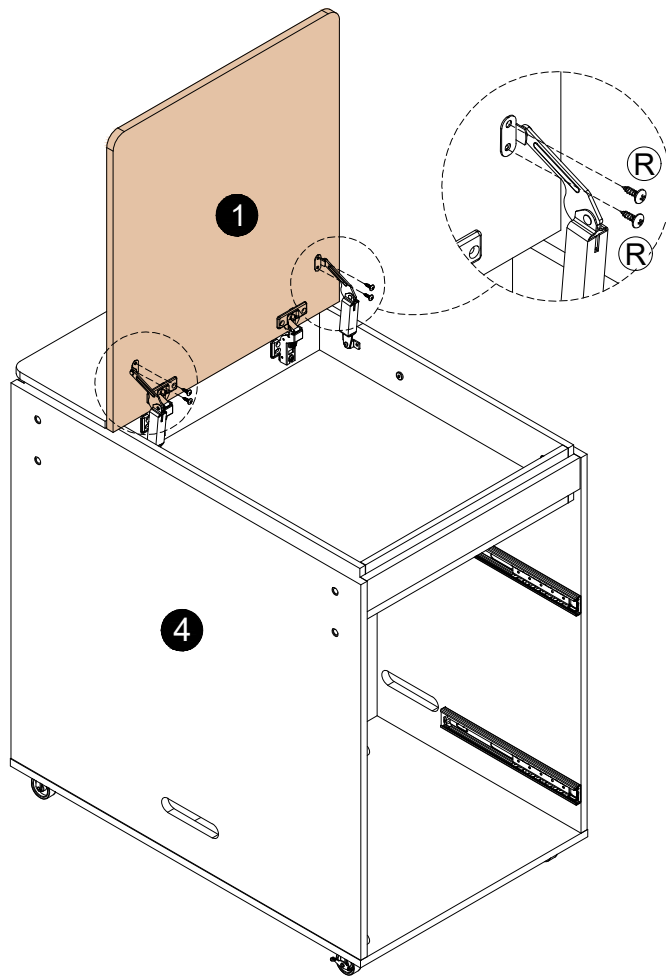
STEP 18**R** X4

STEP 19

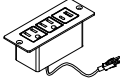
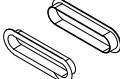
- 
G X2
- 
M X1
- 
O X2

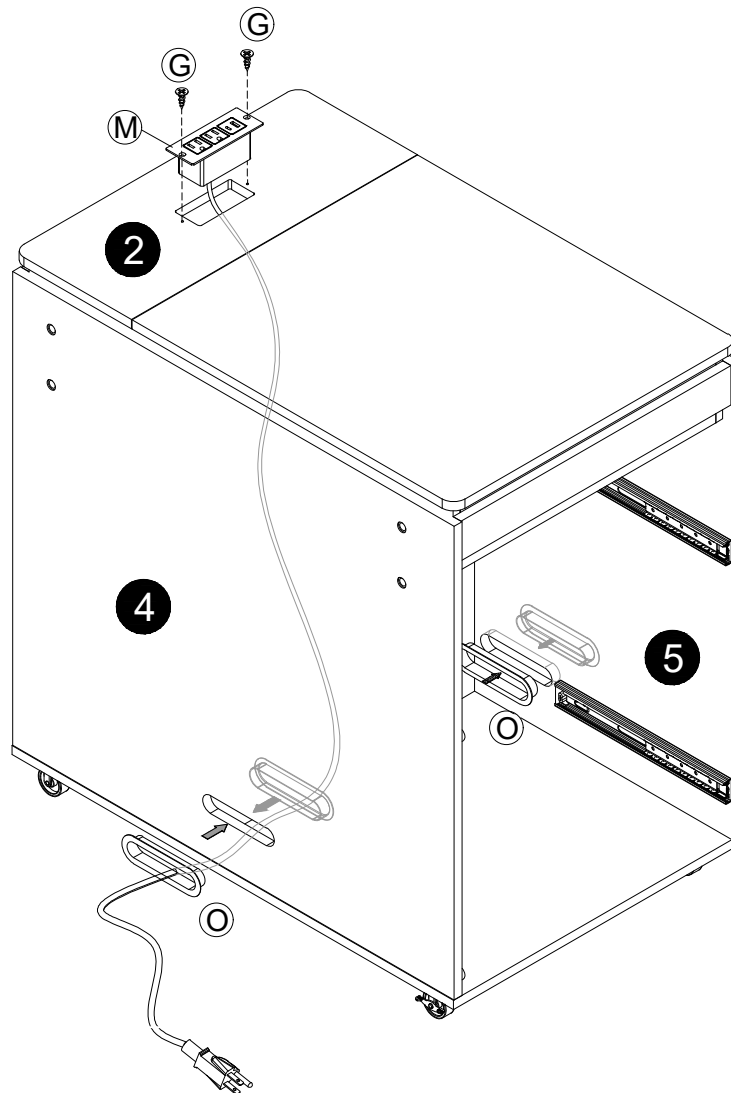

STEP 20

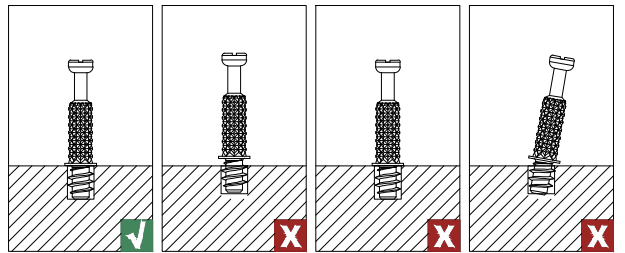
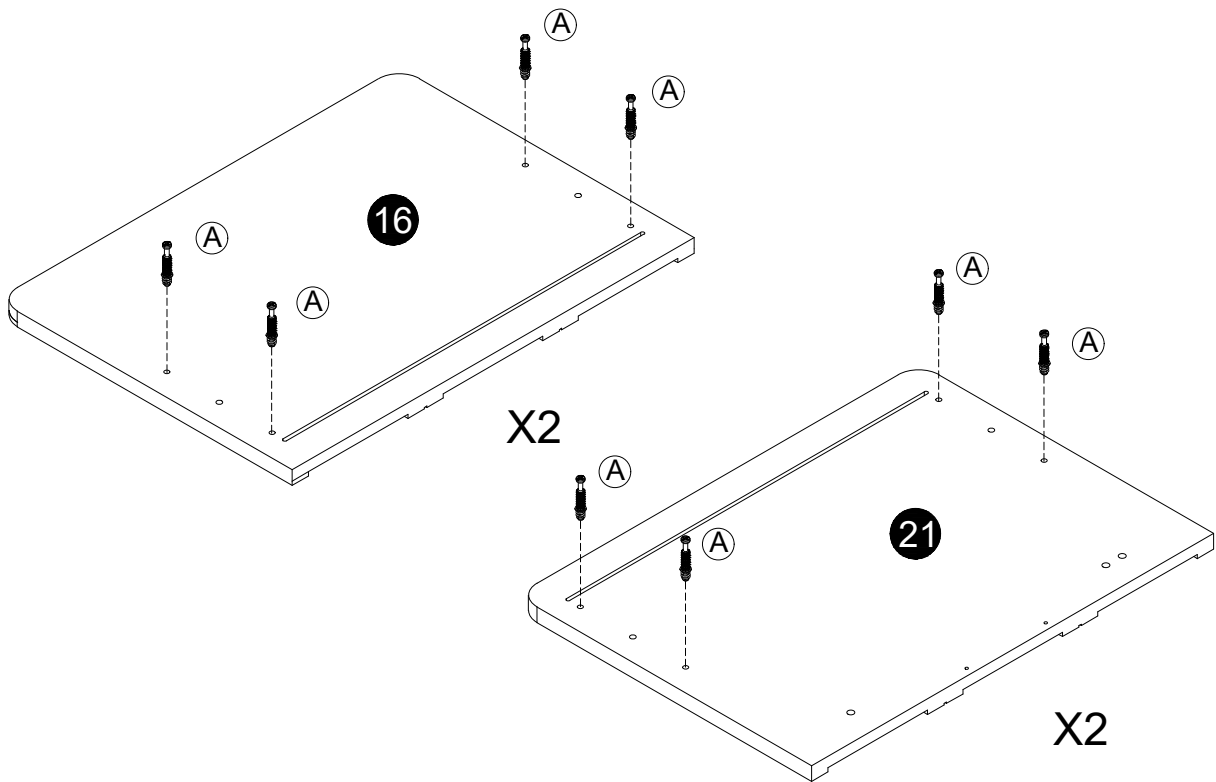

Install the screw correctly to secure the screw.

STEP 21

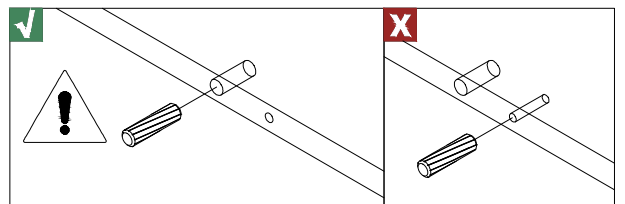
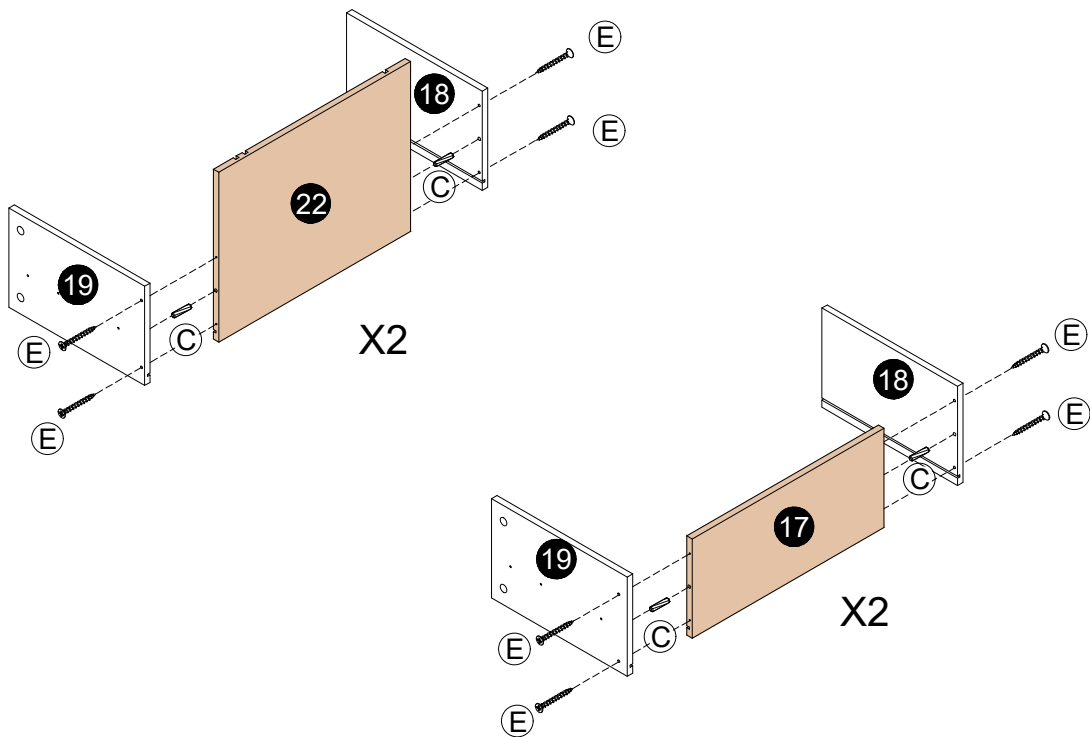

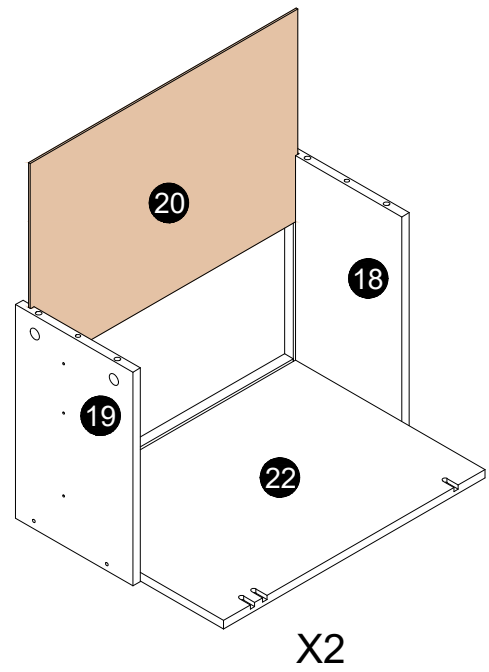
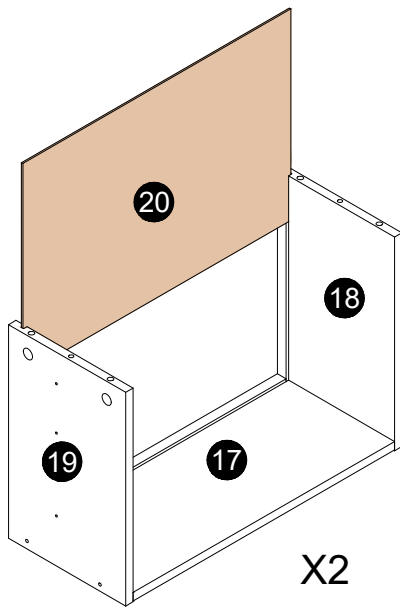
STEP 22

STEP 23





B X16

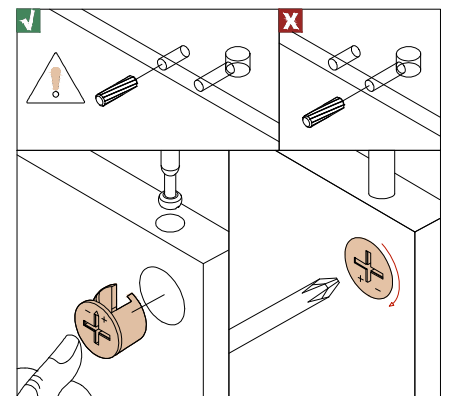
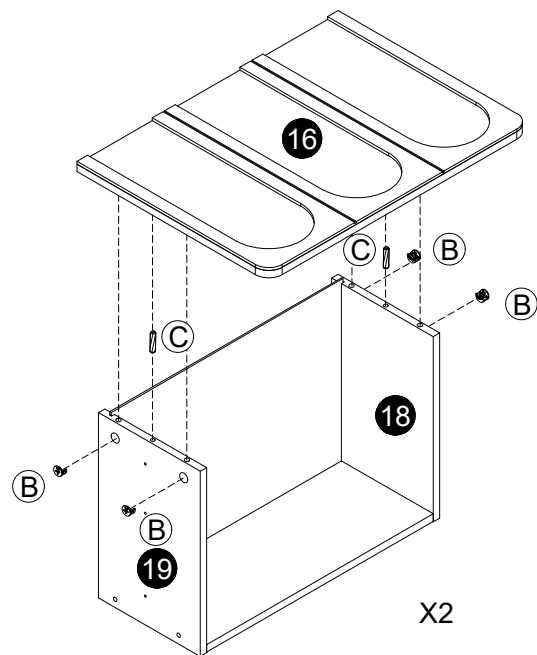
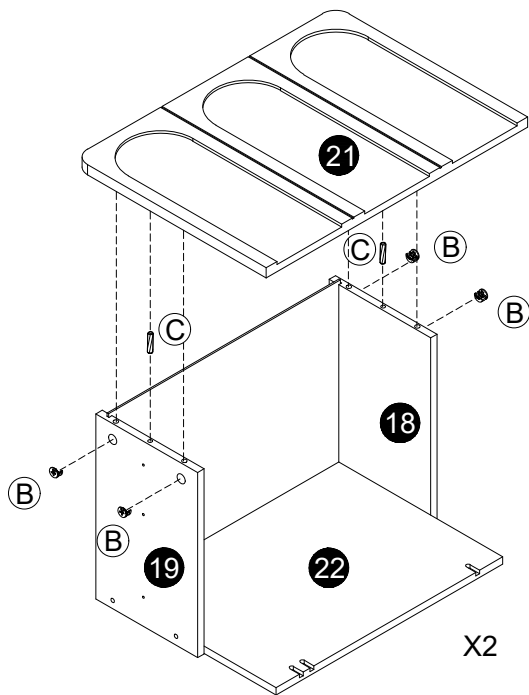

C X8



STEP 24

- 
H X24
- 
Y2 X8

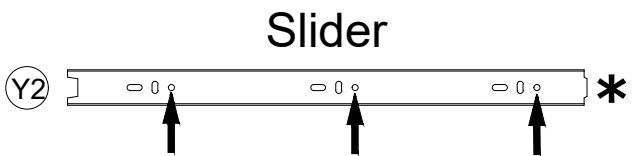
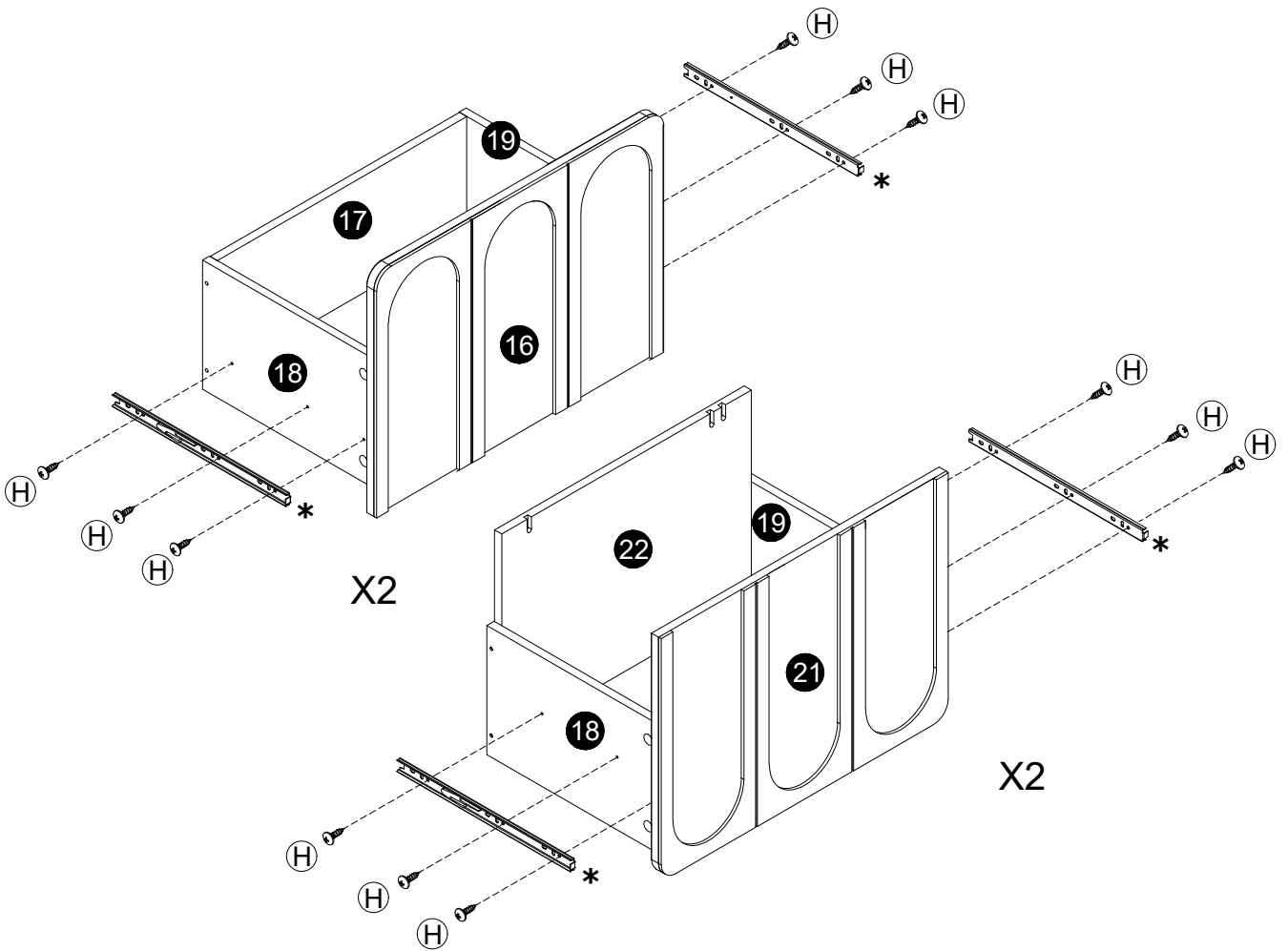

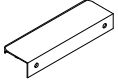
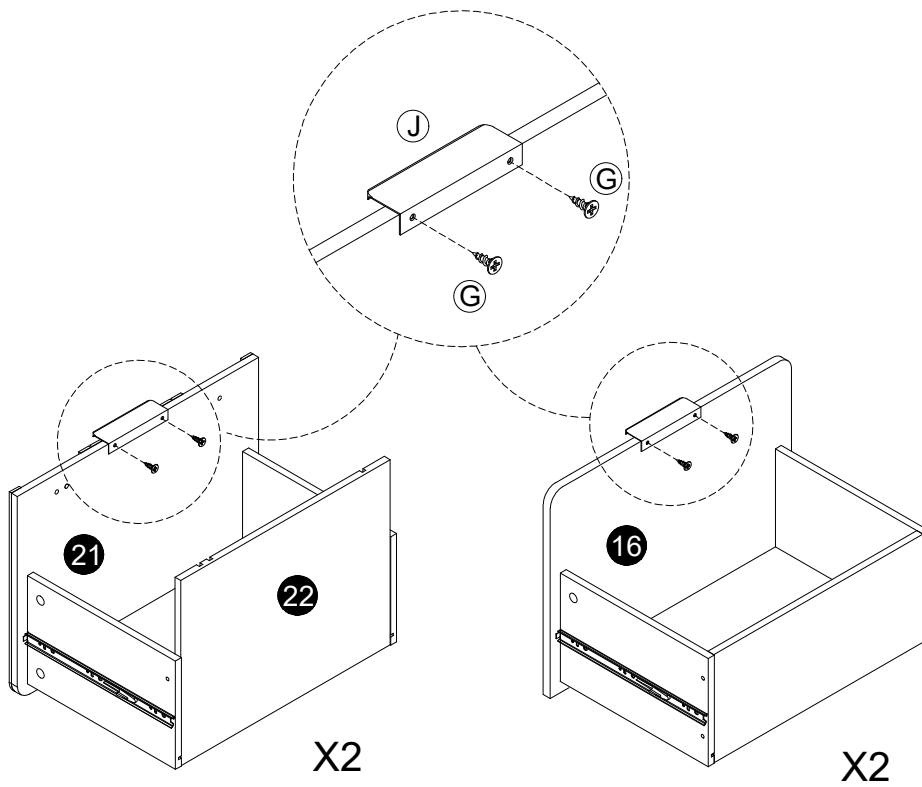
STEP 25**G** X8**J** X4

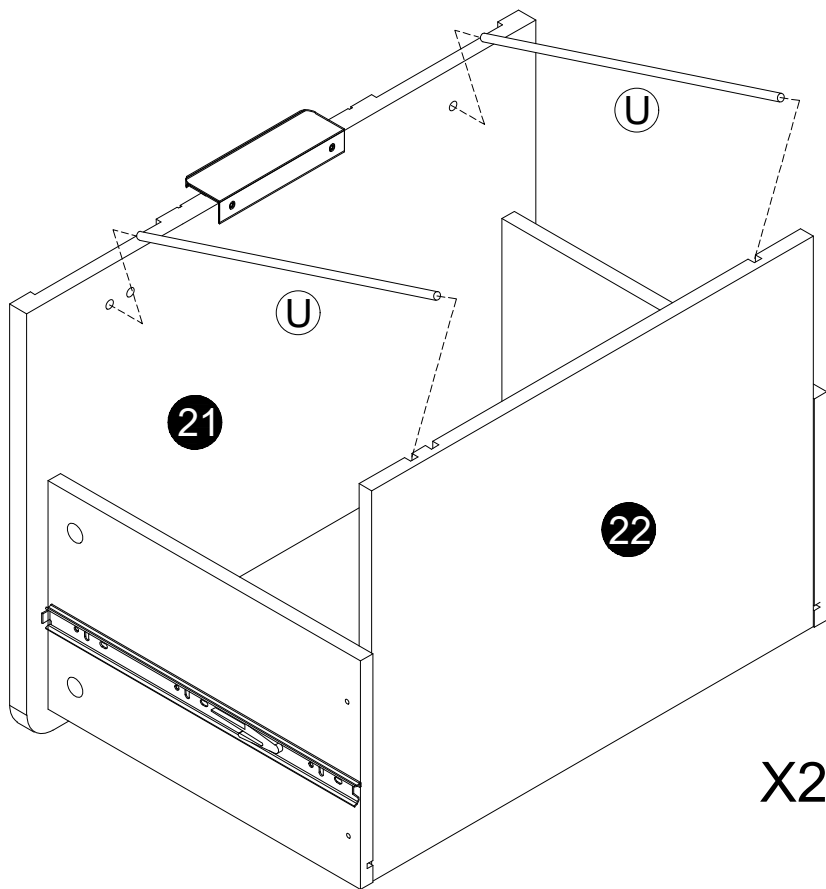
STEP 26

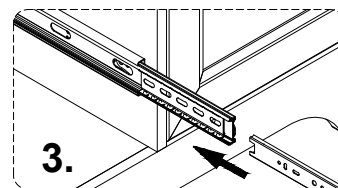
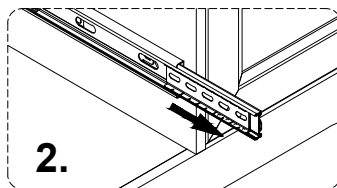
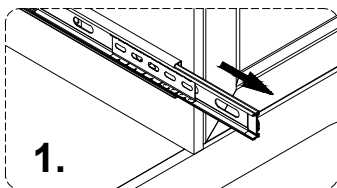
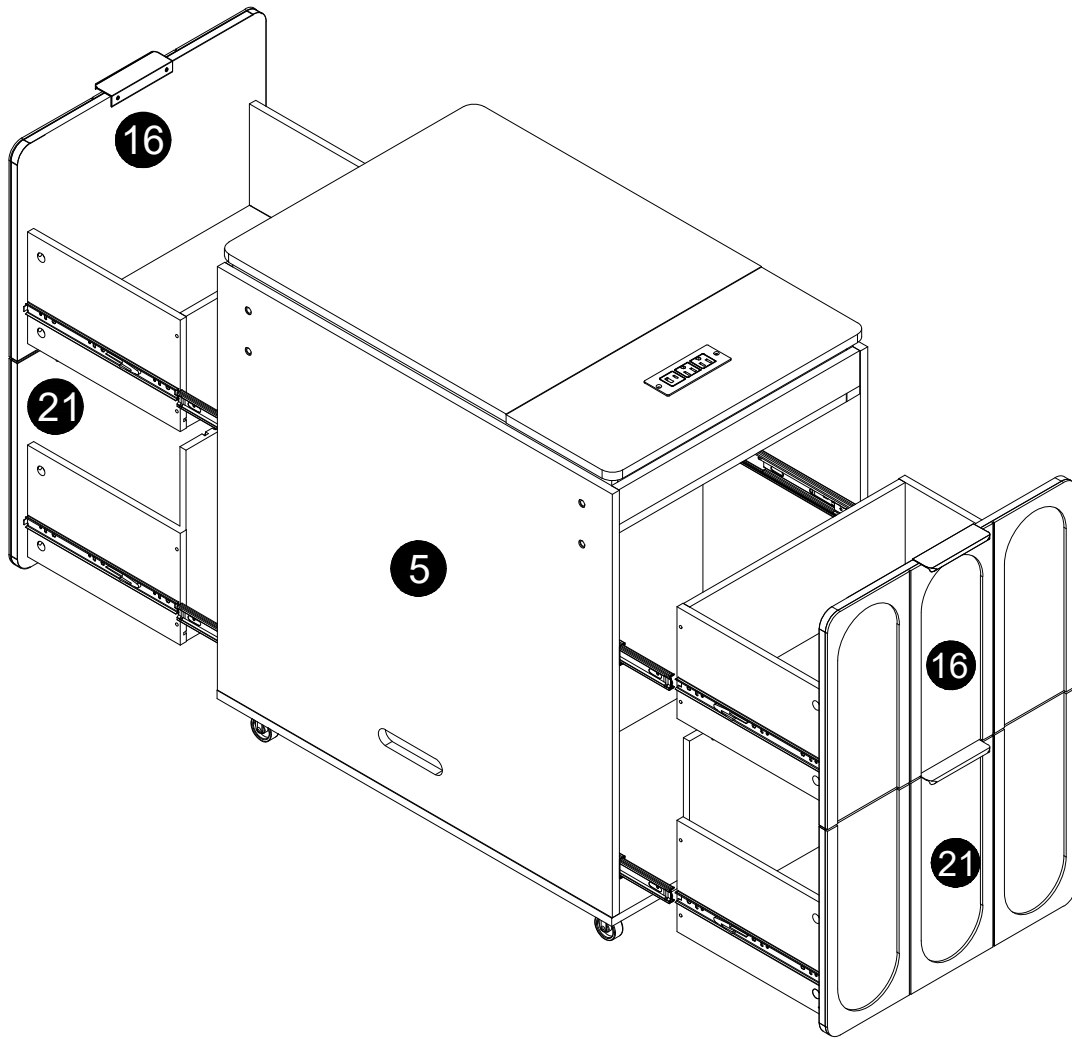
STEP 27

STEP 28

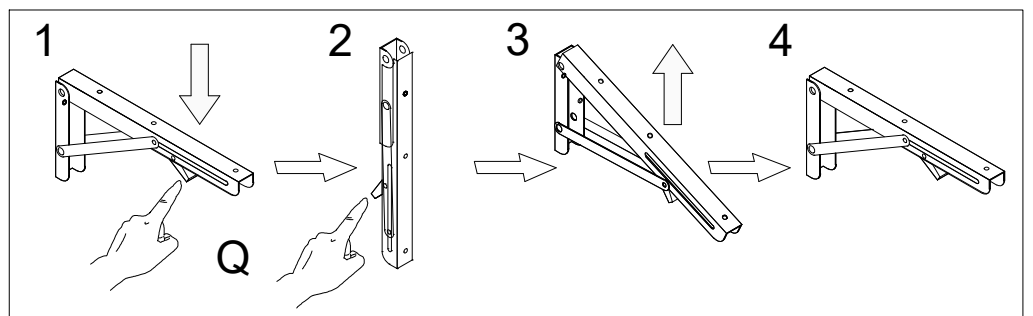
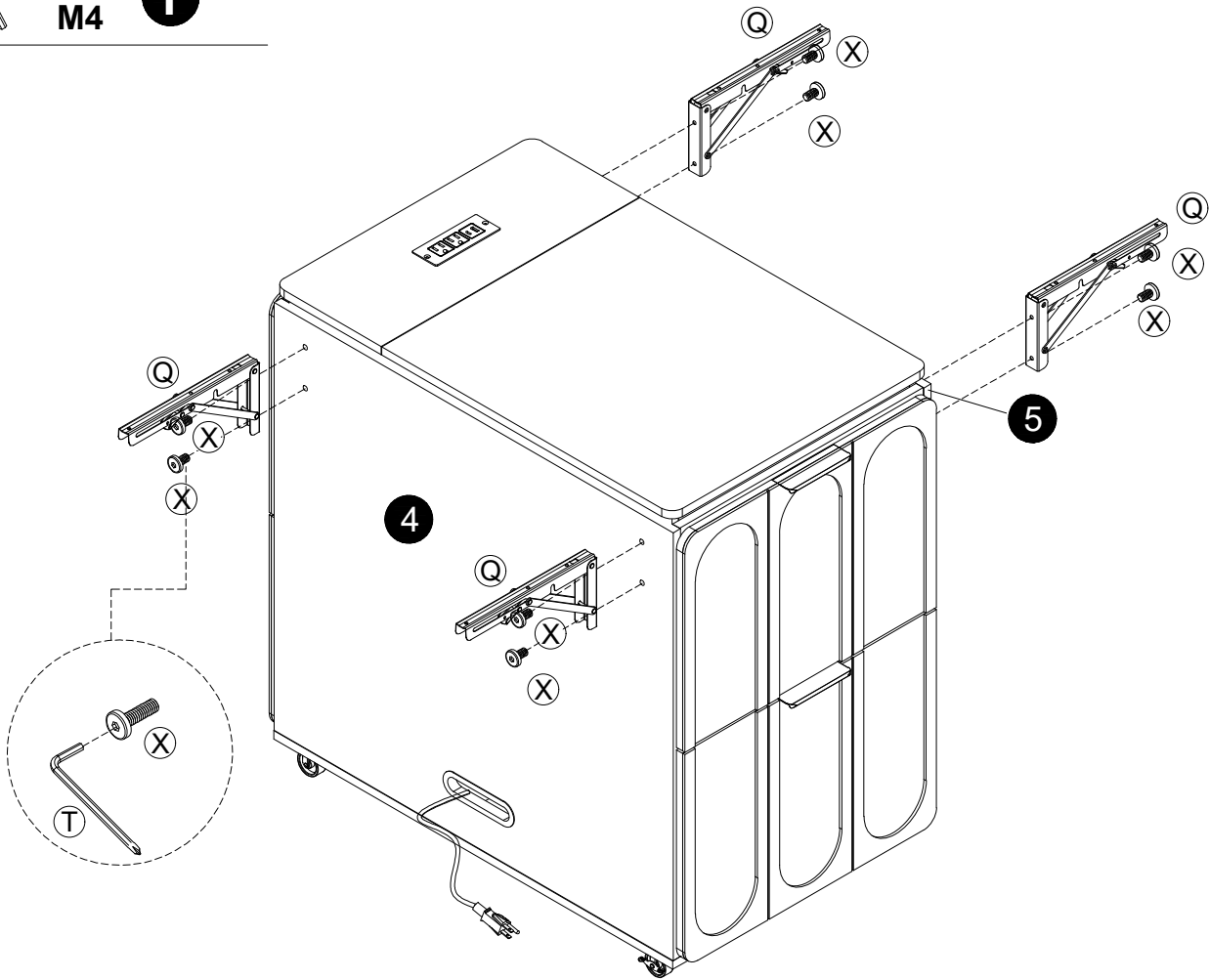

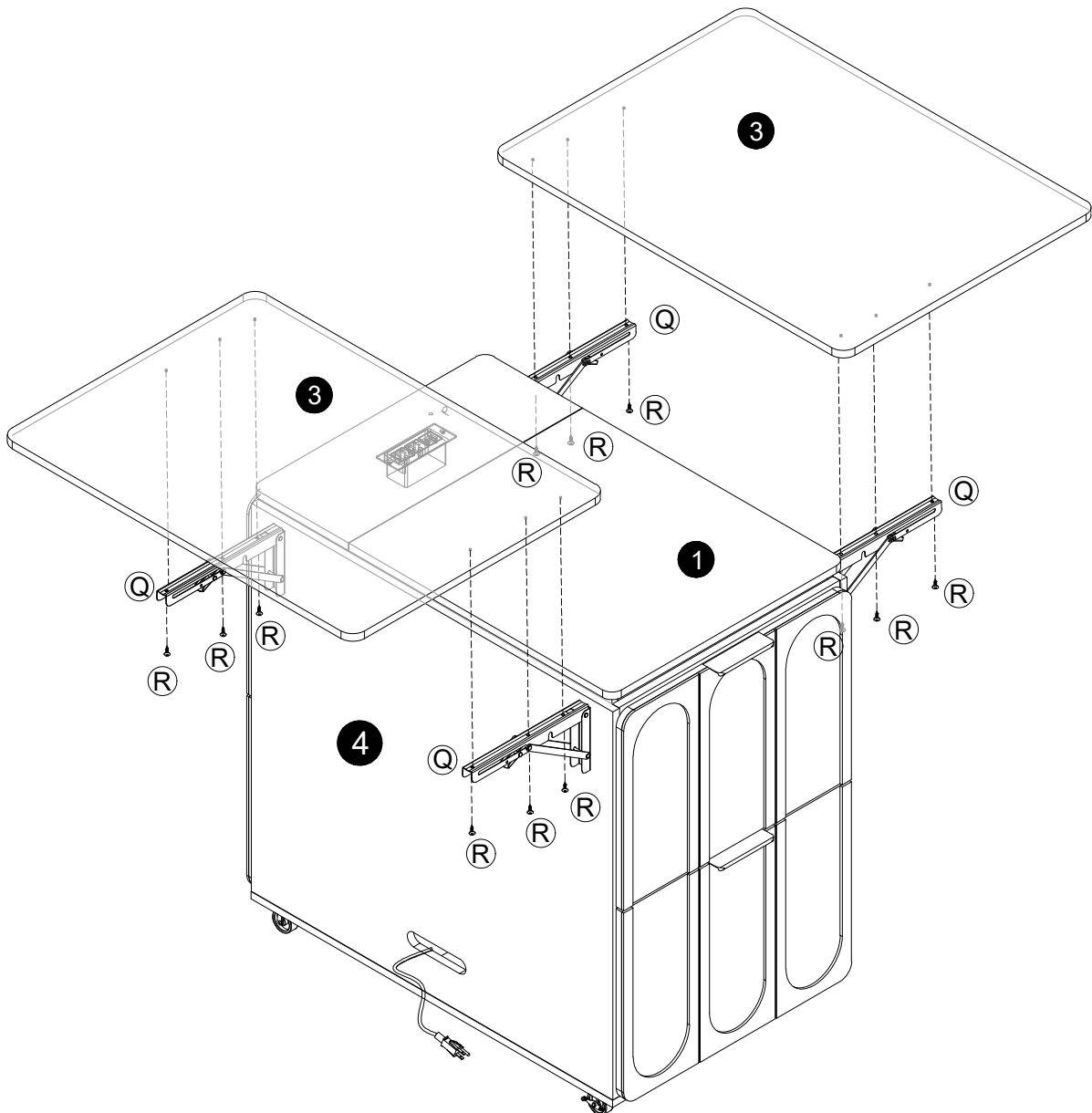
STEP 29**R** X12

STEP 30



N X36

Note: After assembly, cover the holes.

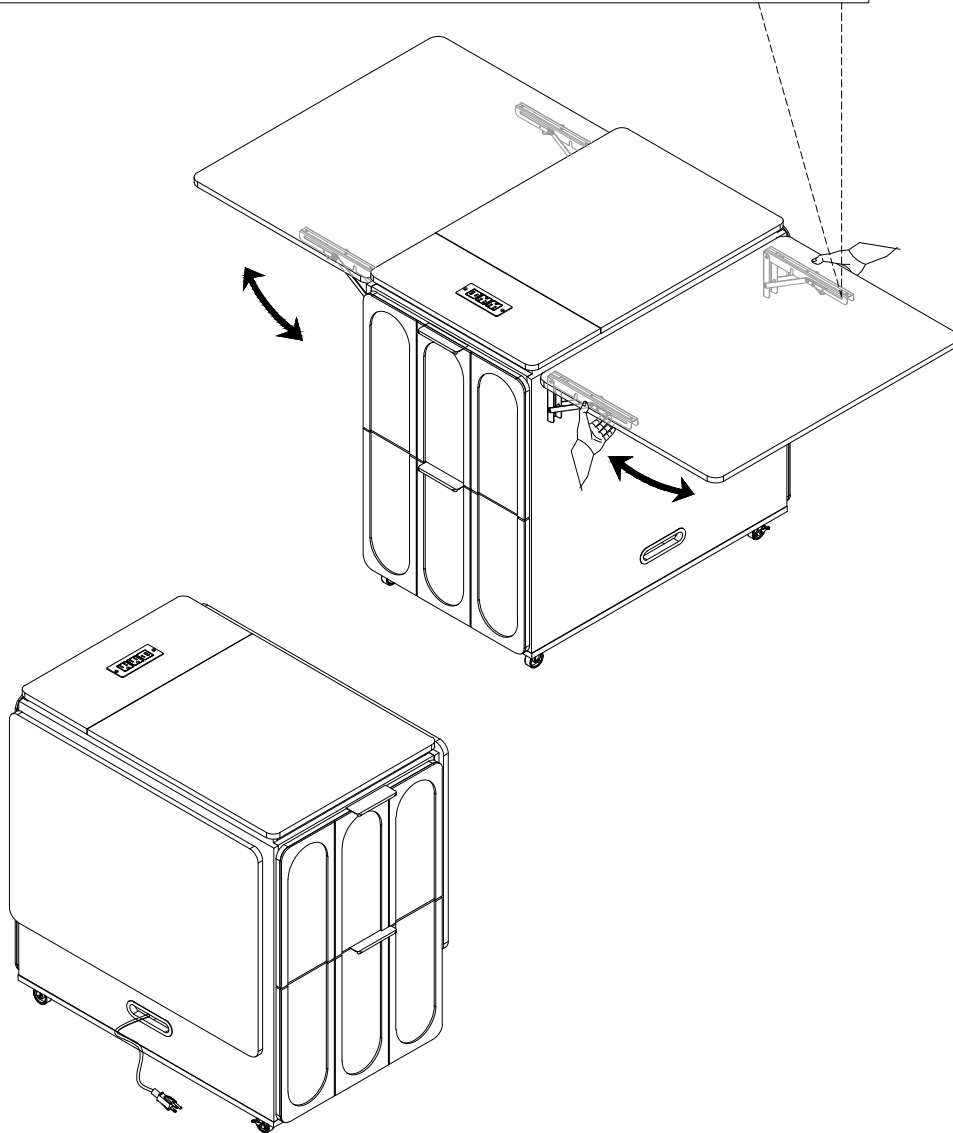
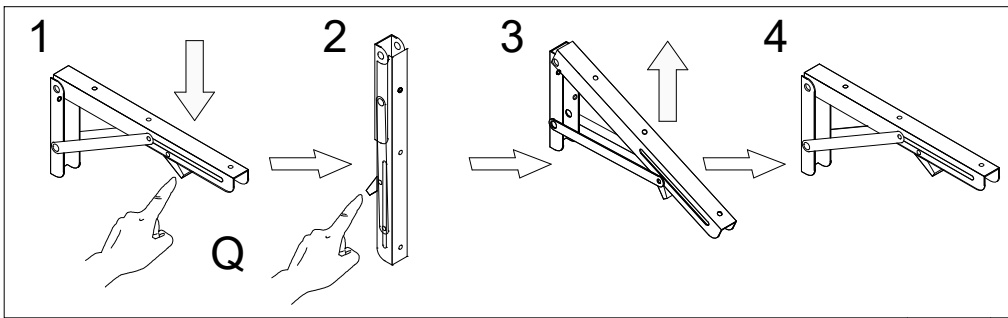



After-Sales Service Hotline: (800) 661-5928