

ASSEMBLY INSTRUCTIONS

BENCH 50"



We are here to help!

We do our best to insure that your furniture arrives in excellent condition. In the event that a part is damaged or missing, We will be happy to provide you with replacement parts, at no charge, within 30 days of purchase, providing the parts are available in our warehouse and the item purchased is part of our current inventory. In order to receive spare parts, at no charge, you must provide proof of purchase within 30 days.

MADE IN CHINA

PARTS IDENTIFICATION

ITEM	DESCRIPTION	QTY
#1	SEAT	01
#2	LEG	06

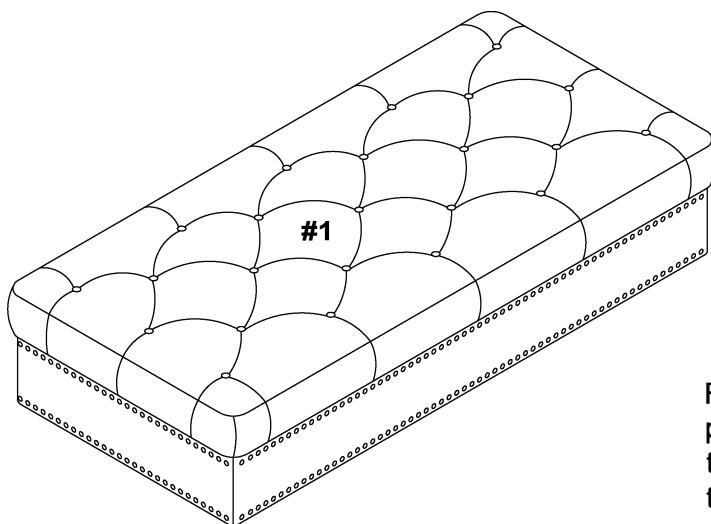

For ease of identification all parts are labeled to correspond to the Step number in which the part is used.

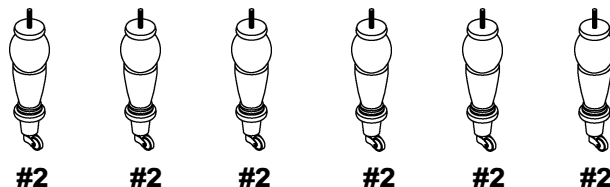

HARDWARE IDENTIFICATION

ITEM	PICTURE	DESCRIPTION	QTY
A		Not to Scale	FLAT WASHER

If any parts are missing or damaged in this package, Linon Home Decor will be happy to provide you with replacement parts, at no charge, within 30 days of purchase, providing the parts are available in our warehouse and the item purchased is part of our current inventory. In order to receive spare parts, at no charge, you must provide proof of purchase within 30 days.

STEP 1.

Take the legs out from the interior space by open the zipper

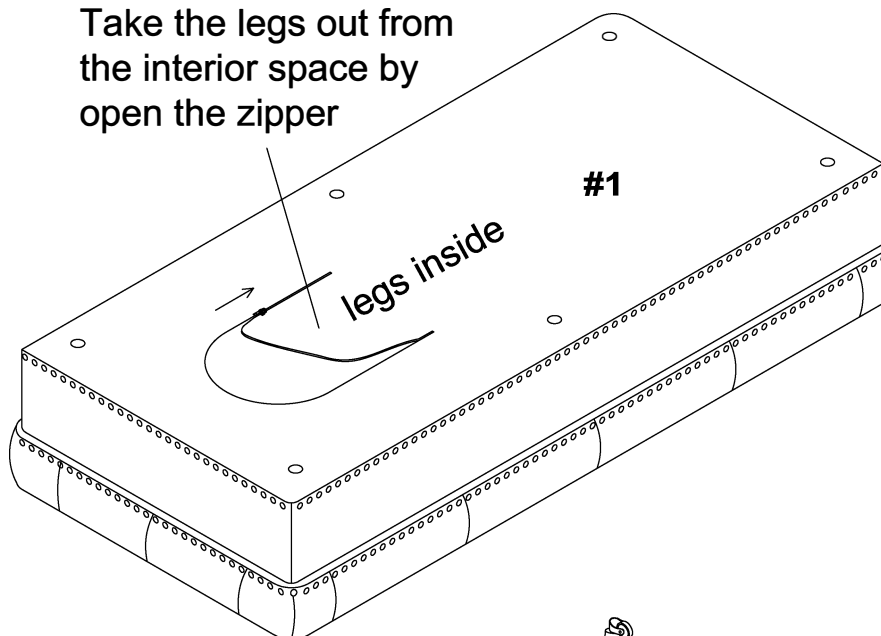

STEP 2.

ADJUSTABLE LEVELER

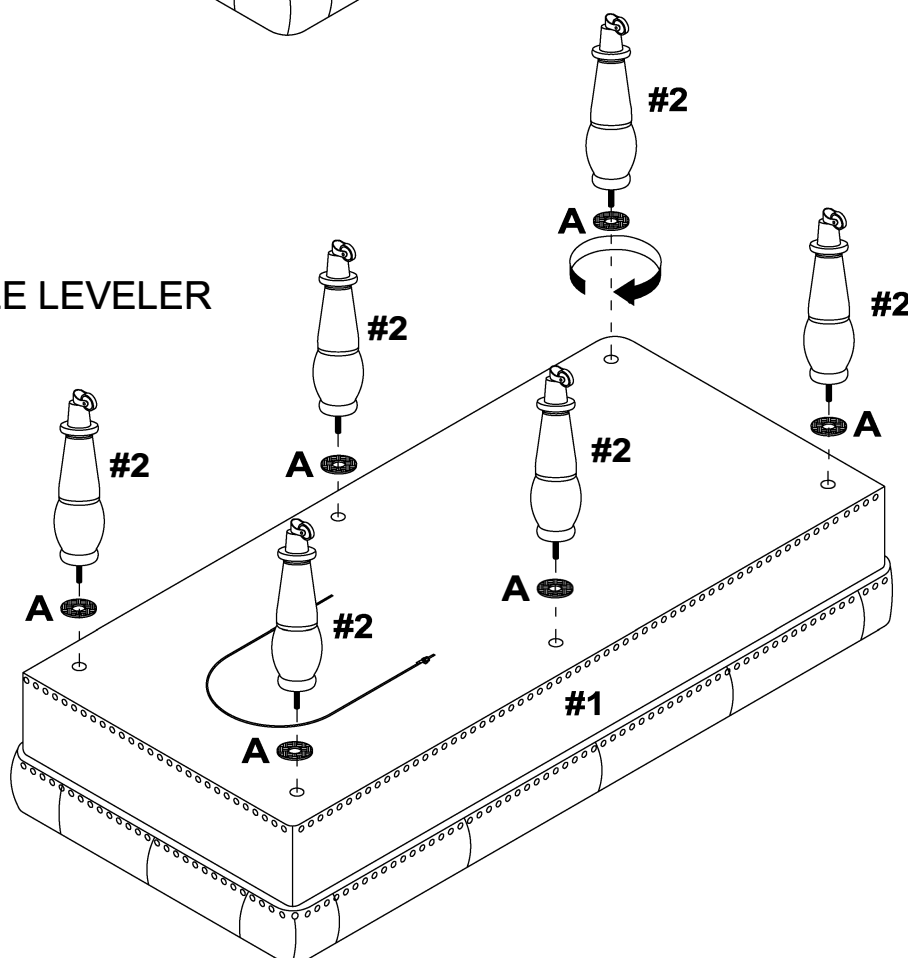

IMPORTANT:

1. DO NOT TIGHTEN BOLTS COMPLETELY UNTIL ALL BOLTS ARE COMPLETELY LINED UP AND INSERTED INTO HOLES / NUTS.
2. DO NOT OVER TIGHTEN SCREWS AND BOLTS TO AVOID STRIPPING.

LIMITED 6 MONTHS WARRANTY

WHAT IS COVERED

This product is covered under our manufacturer's 6 months limited warranty. To ensure your complete satisfaction, this warrants to the original purchaser that the supplied item is free from defects in material and workmanship, as of the date of purchase, and that it will, under normal use and proper care, remain so for six months after the date of purchase.

Replacement of missing or initially defective parts will be sent, at no charge, for a period of 30 days from the date of purchase with valid proof of purchase providing the parts are available in our warehouse and the item purchased is part of our current inventory.

WHAT IS NOT COVERED

It remains the customer's responsibility for freight and packaging charges to and from the customer service center. Labor and material charges to remove or replace parts under this warranty are not covered.

This warranty does not cover: Furniture used for commercial purposes, failures caused by improper installation assembly or by improper care, unreasonable or abusive use (do not stand on this chair; weight limit 275 lbs), freeze damage, acts of God, rust, purchased parts or return freight and packaging charges. Proof of purchase (dated register receipt) is required for warranty claims.

HOW TO OBTAIN SERVICE

For further information, please contact our customer service department between 9:00 AM and 5:00 PM Eastern Standard Time, Monday through Friday: