

Assembly Instructions

Caution: You must read this before you proceed

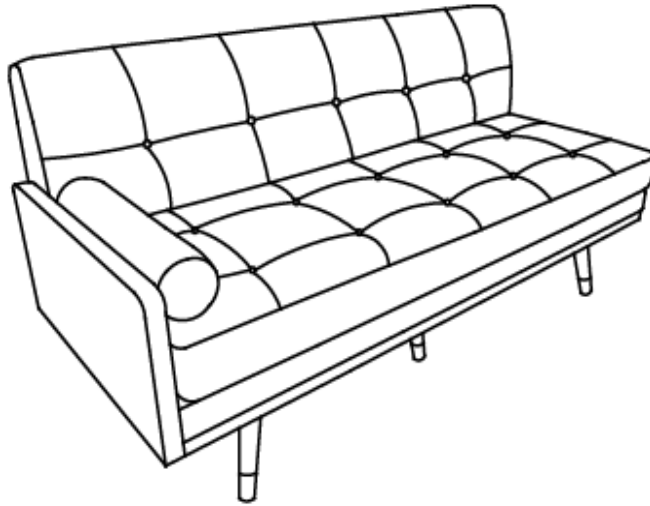

Please look in seat for hardware packs and legs.

Sofa

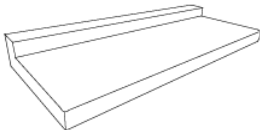
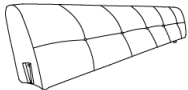
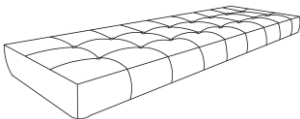
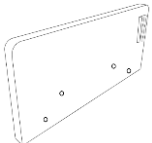
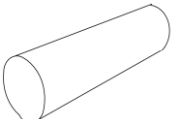

Parts List

Label	Picture	Description	QTY
A		Sofa Base	1
B		Backrest	1
C		Seat Cushion	1
D		Left Arm Board	1
E		Arm Pillow	1

F		Middle Wooden Leg with 1 Plastic Gasket	1
G		Wooden Leg with 1 Plastic Gasket	4

Hardware List

Label	Picture	Description	QTY
①		Bolt (M6*70mm)	5
②		Big Washer(φ30mm)	2
③		Small Washer(φ24mm)	5
④		Spring Washer	7
⑤		Double-threaded Bolt (M8*70mm)	2
⑥		Wing Nut	2
⑦		Allen Key	1
⑧		Plastic Gasket	3

Assembly Preparation

Before Beginning
Assembly:

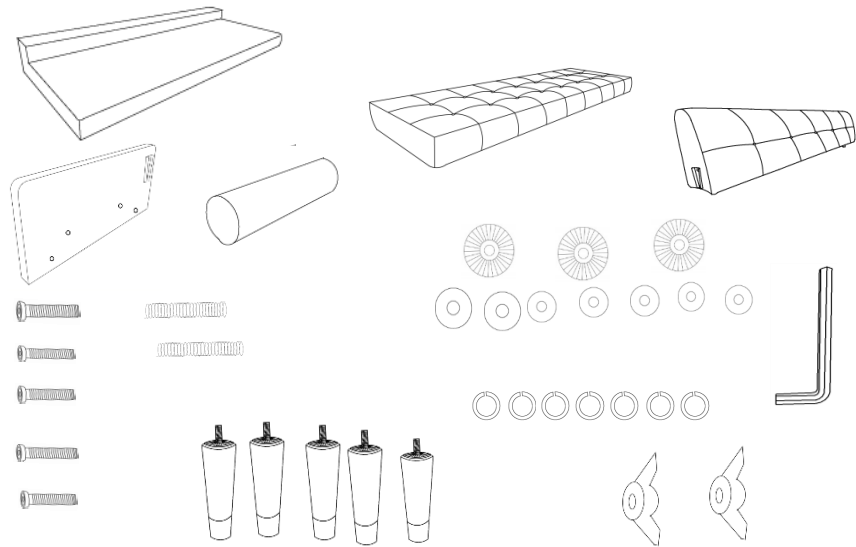

- Read instructions, cover to cover-



- Have 2 adults on hand for assembly-



- Do not assemble on flooring or carpet-



- Assemble on a clean non-marring surface (packing foam)-



- Save all packaging until finished-

Assembly Steps

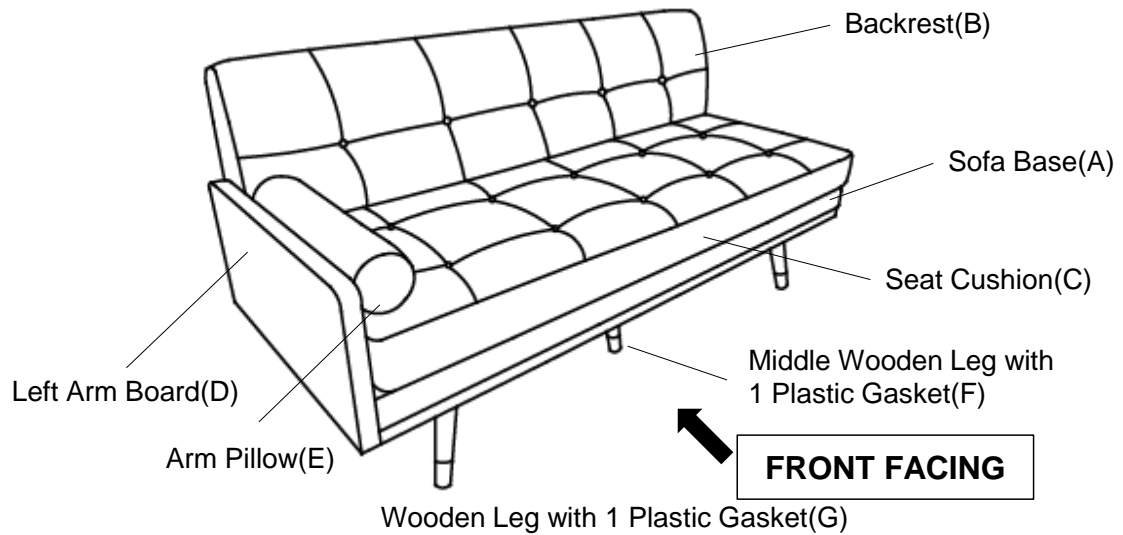

This Sofa has multiple parts and may require about 30 minutes to assemble. To give you an overview of the Sofa parts, the above picture is to help you put the various parts into perspective. Please read through the instructions below to familiarise yourself with the parts and steps before assembly.

Step 1

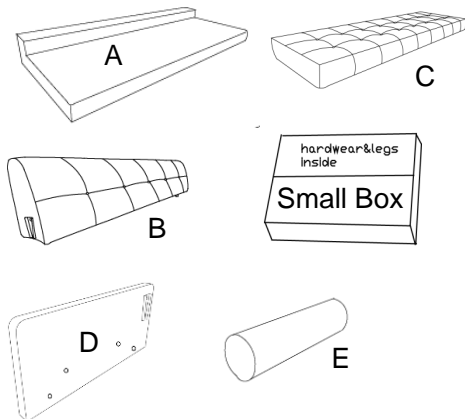
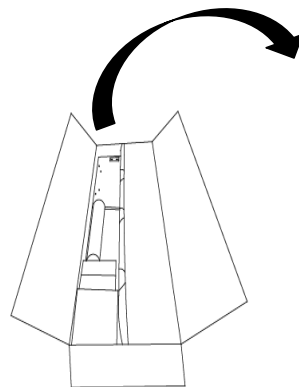

Take The Sofa Base(A),Backrest(B), Seat Cushion(C), Left Arm Board(D),Arm Pillow(E) and Small Box out of the carton and place them on a clean, non-marring surface.

Step 2

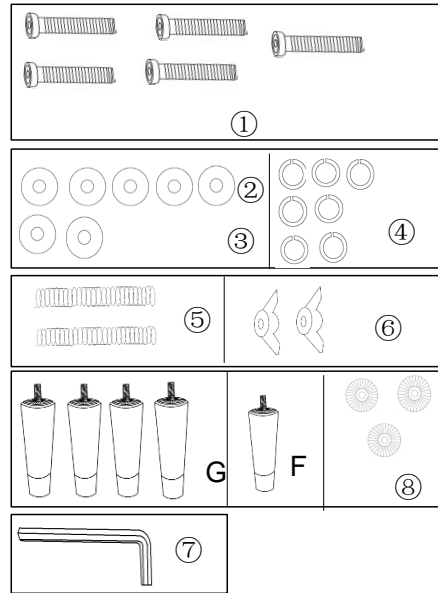
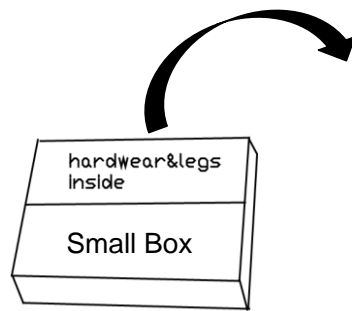

Open the Small Box and take out the Middle Wooden Leg with 1 Plastic Gasket(F), Wooden Leg with 1 Plastic Gasket(G), Plastic Gaskets(7), Bolts(1), Big Washers(2), Small Washer(3), Spring Washers(4), Double-threaded Bolts(5), Wing Nuts(6), Allen Key(7) and Plastic Gasket(8).

Step 3

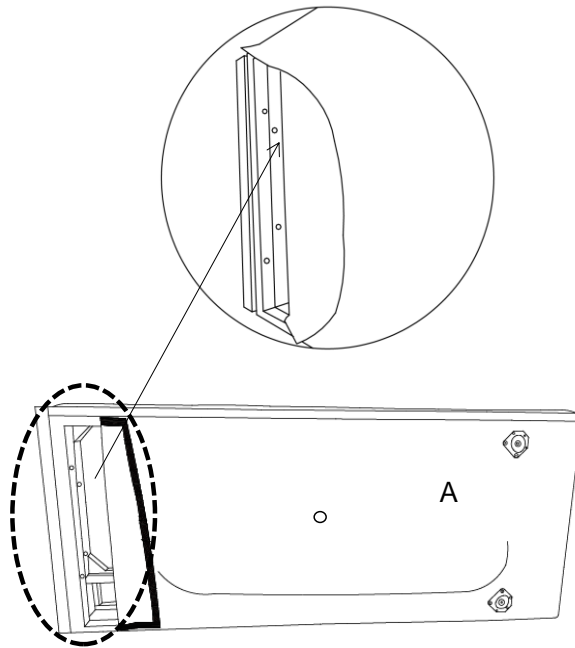

Carefully peel back the Non-woven cover under the Seat Base(A) to expose the mounting positions as Circled.

Step 4

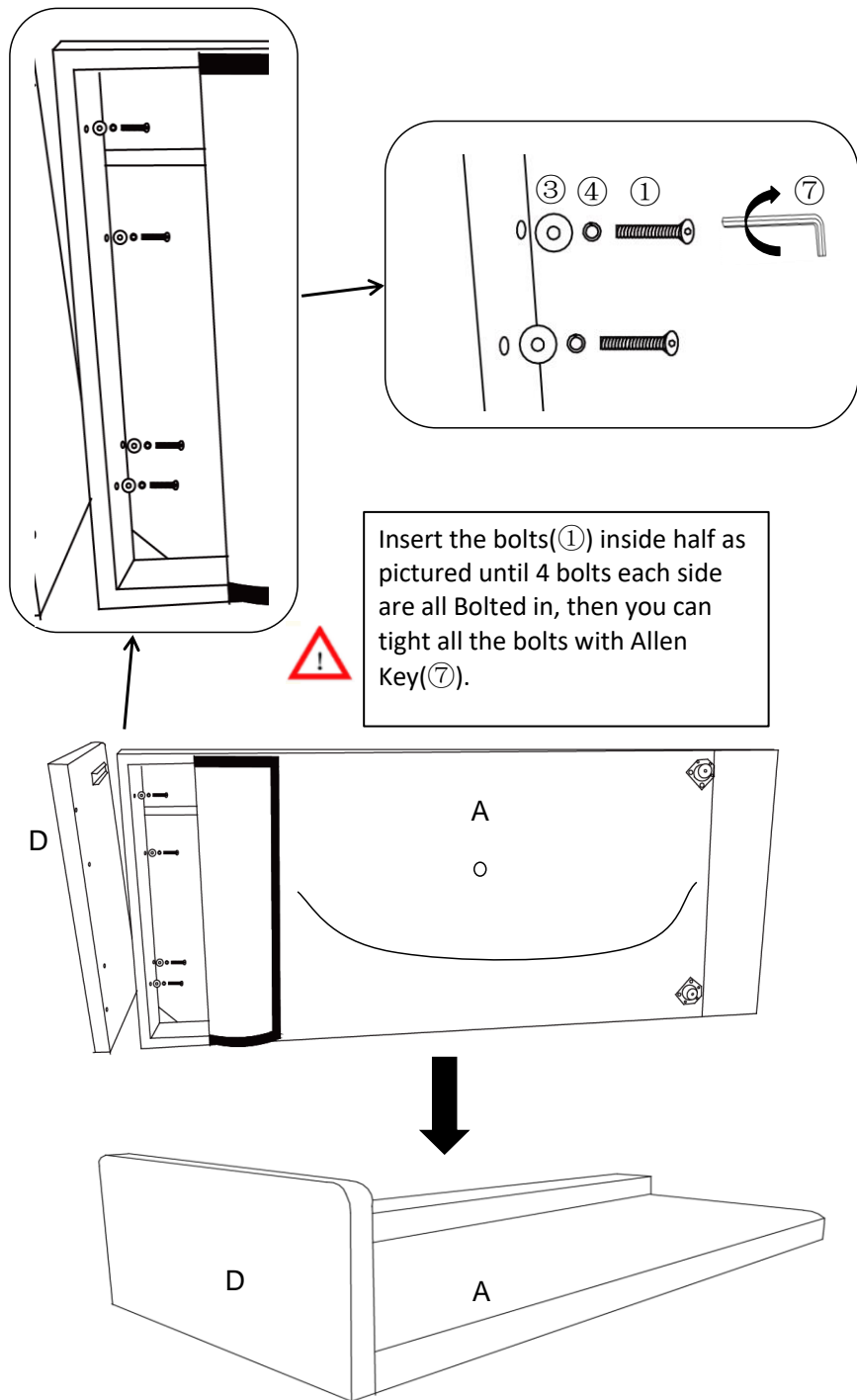

Insert the bolts(①) inside half as pictured until 4 bolts each side are all Bolted in, then you can tight all the bolts with Allen Key(⑦).

With assistance from your adult partner,
Align Left Arm Board(D) on the left side of the Sofa Base(A).
Attach Left Arm Board(D) to Sofa Base(A) using Bolts(①) Spring Washers(④), and Washers(③) with Allen Key(⑦).

Tighten the Bolts fully in a sequential manner.

Step 5

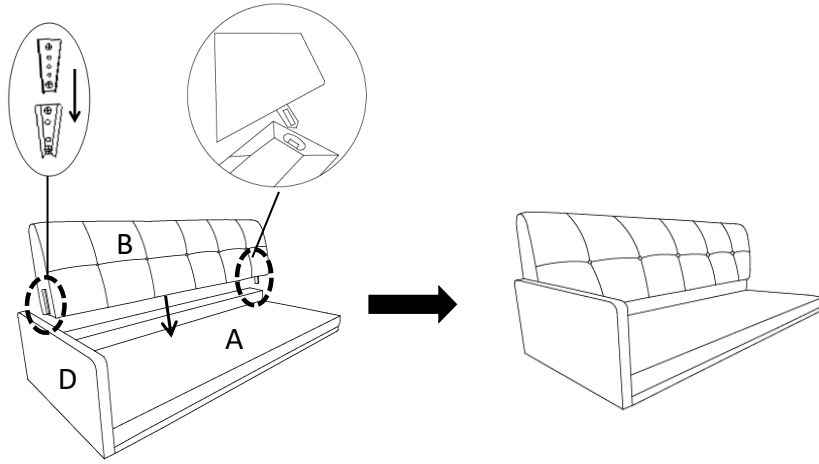

With assistance from your adult partner, hold up the Backrest(B), while standing behind the Sofa Base(A).

Align the mounting bracket on Left side of the Backrest(B) with those on the Left Arm Board(D) .

Then slide Sofa Backrest(B) downward by hand to make sure it locks into place as pictured.

Step 6

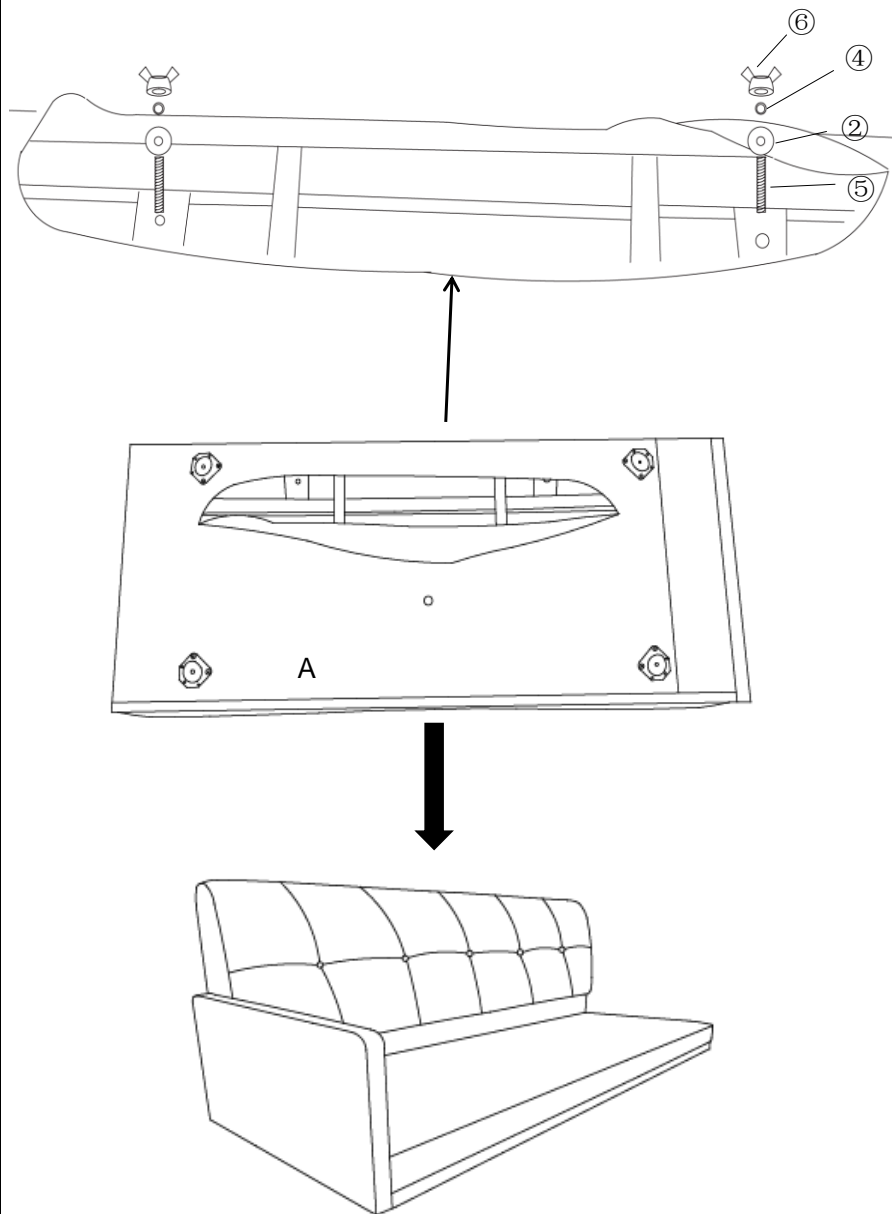

You will see two mounting positions on the hind-top panel of the Sofa Base(A).
 Insert Double-threaded Bolts(⑤) into mounting positions and tighten clockwise by hand.
 Then, place Washer Rings(②) and Spring Washers(④) onto the Double-threaded Bolts(⑤), and secure using Wing Nut(⑥).
Tighten Wing Nuts fully by turning it clockwise by hand in a sequential manner, then close the back non-woven cover under Sofa Base(A) with Velcro.

Step 7

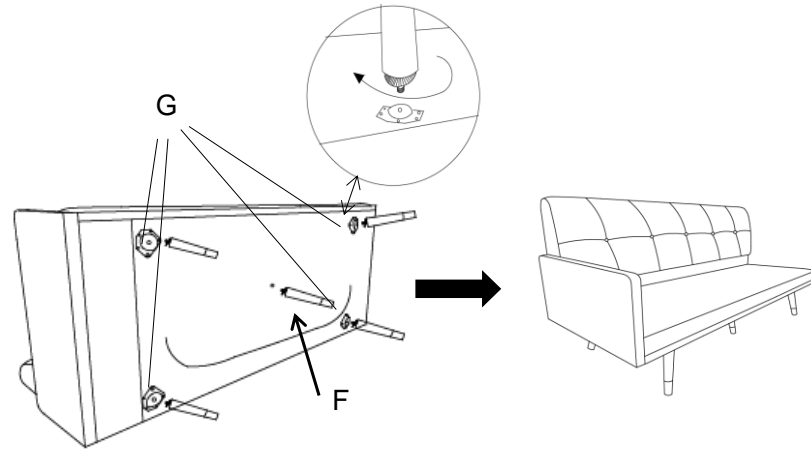

Install the Wooden Leg with 1 Plastic Gasket(G) and Middle Wooden Leg with 1 Plastic Gasket(F) at the bottom of the Sofa Base(A) .
 Tighten by turning the Leg clockwise.

1.Note: The use of Gaskets are OPTIONAL and are especially useful to help alleviate slight wobbleness. Some Legs may need more than one Gasket whilst some Legs may not need any.

2.Note: The Middle Leg(F) is shorter than other Wooden Leg(G), and is used in the middle of the seat frame

Step 8

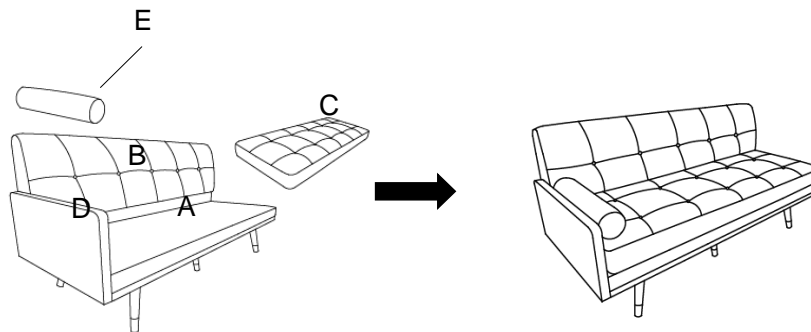

Put the Seat Cushion(C) on the Sofa Base(A) and the place the Arm Pillow(E) on the Seat Cushion(C) against the Left Arm Board(D).

Your Sofa is ready for use.





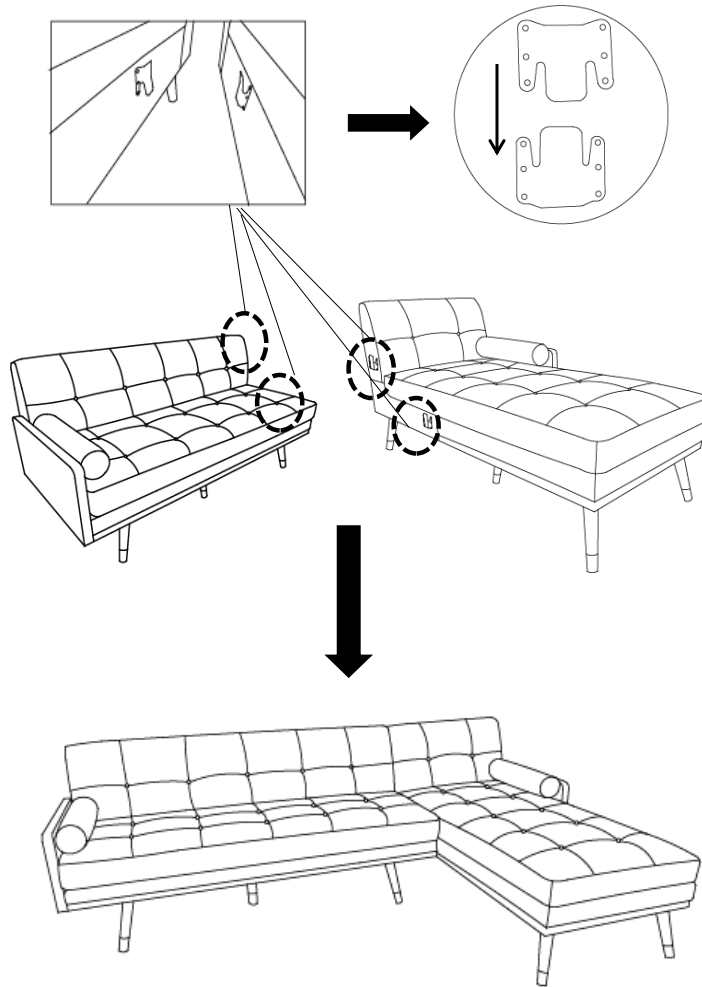















This Sofa can only be used on a flat, level surface.

Step 9



Connect the LHF Sofa and RHF Chaise by intersecting the metal Brackets as pictured(this process until finish the assemble of RHF Chaise)
Your Sectional is ready for use.
This Sectional can only be used on a flat, level surface.

Care & Maintenance

-   ● Do not put hot items directly on furniture surface
 -   ● Do not clean furniture with harsh cleansers or polish.
 -   ● Do not place furniture under direct sunlight.
 -   ● Do not place furniture near heating or cooling vents.
 -   ● Do not write on furniture without a padded barrier to protect the surface.
 -   ● Do not place furniture outside . For indoor use only .
 -   ● Not for commercial use. For residential use only .
 -   ● Stains may be removed with mild soap solution and damp cloth.
 -   ● Children should not climb or jump on the furniture.
-
-   ● Dust and pick-up spills using a clean, non-colored, lint-free cloth .

Questions & Answers about Proposition 65

• What is Proposition 65?

Proposition 65 requires businesses to provide warnings to Californians about significant exposures to chemicals that cause cancer, birth defects or other reproductive harm. These chemicals can be in the products that Californians purchase, in their homes or workplaces, or that are released into the environment. By requiring that this information be provided, Proposition 65 enables Californians to make informed decisions about their exposures to these chemicals.

Proposition 65 also prohibits California businesses from knowingly discharging significant amounts of listed chemicals into sources of drinking water.

Proposition 65 requires California to publish a list of chemicals known to cause cancer, birth defects or other reproductive harm. This list, which must be updated at least once a year, has grown to include approximately 900 chemicals since it was first published in 1987.

• What types of chemicals are on the Proposition 65 list?

The list contains a wide range of naturally occurring and synthetic chemicals that include additives or ingredients in pesticides, common household products, food, drugs, dyes, or solvents. Listed chemicals may also be used in manufacturing and construction, or they may be byproducts of chemical processes, such as motor vehicle exhaust.

• What does a warning mean?

If a warning is placed on a product label or posted or distributed at a workplace, a business, or in rental housing, the business issuing the warning is aware or believes that it is exposing individuals to one or more listed chemicals.

By law, a warning must be given for listed chemicals unless the exposure is low enough to pose no significant risk of cancer or is significantly below levels observed to cause birth defects or other reproductive harm.

• Where can I get more information on Proposition 65?

If you have specific questions on the administration or implementation of Proposition 65, you can contact OEHHA's Proposition 65 program at P65.Questions@oehha.ca.gov, or by phone at (916) 445-6900.