

# ASSEMBLY INSTRUCTION INSTRUCTIONS DE MONTAGE

## FULL BED

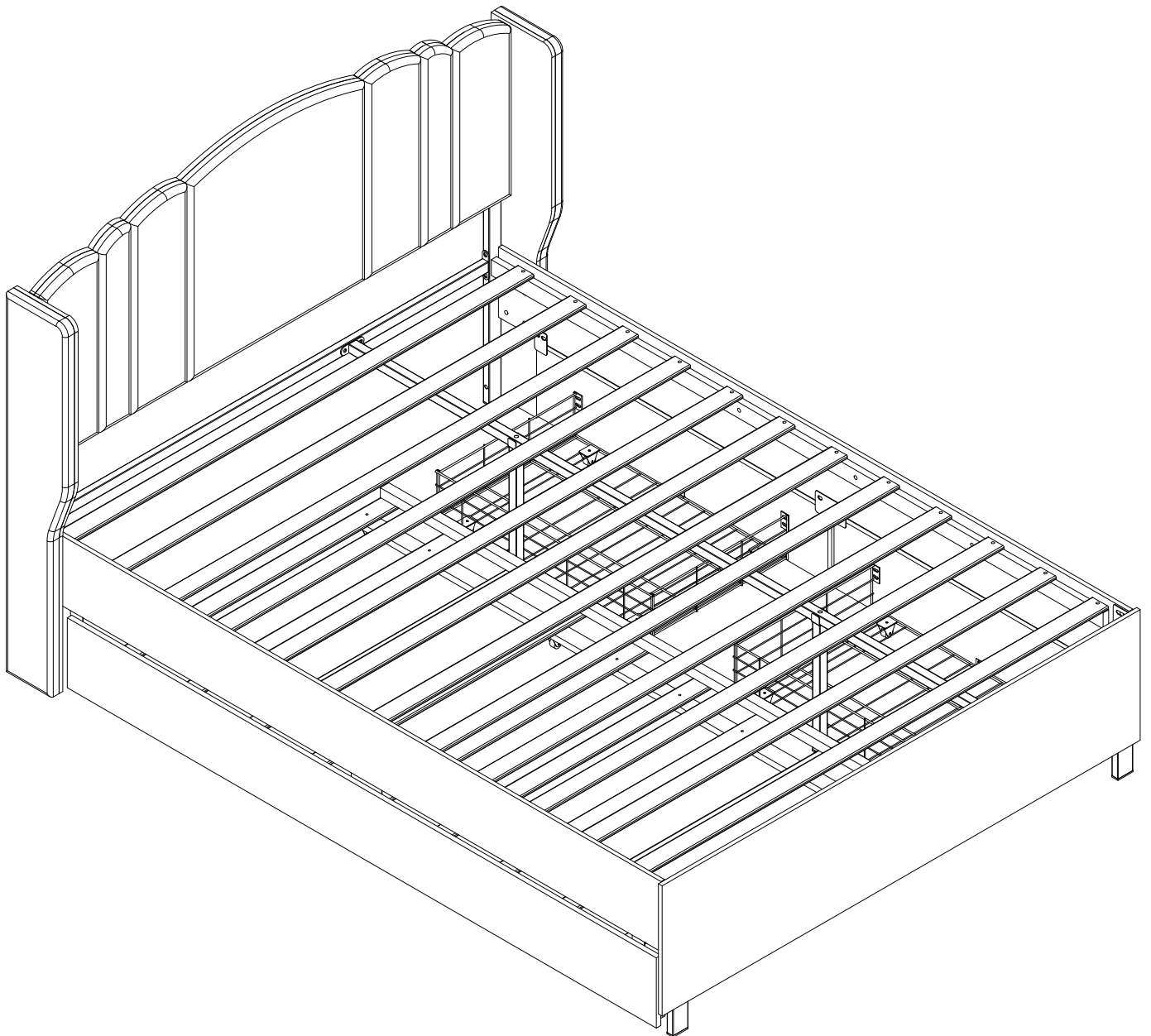

N733P208132/N733P208140

# Explosion diagram of components

## Diagramme d'explosion des composants

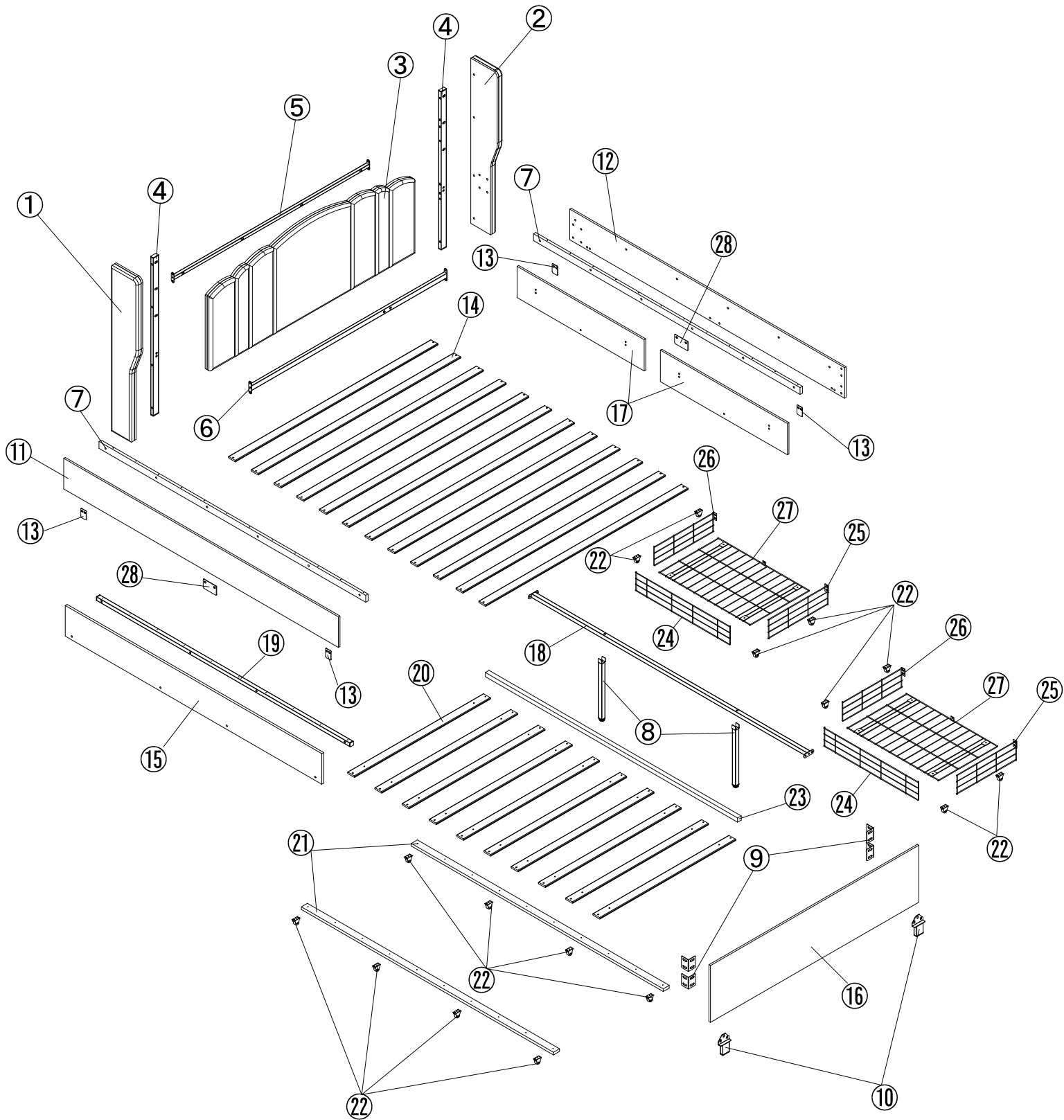

# ASSEMBLY INSTRUCTION INSTRUCTIONS DE MONTAGE

## PARTS LIST / LISTE DE PIÈCES



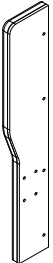
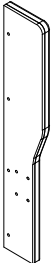
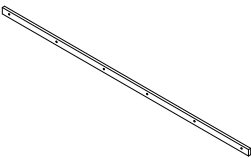
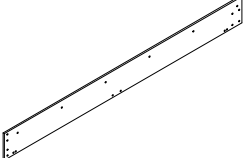
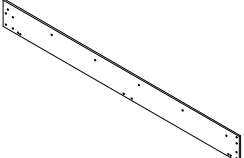
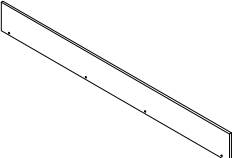
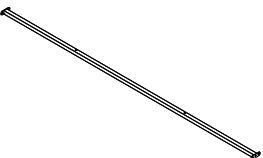
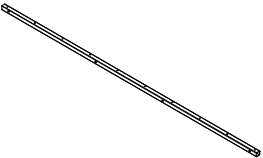
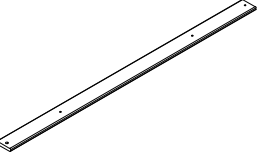
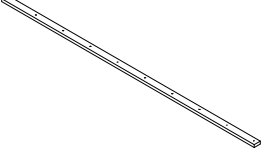
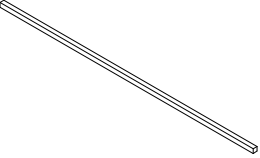



N733P208132

				
①*1	②*1	⑦*2	⑪*1	⑫*1
				
⑮*1	⑱*1	⑲*1	⑳*10	㉑*2
				
㉓*1				

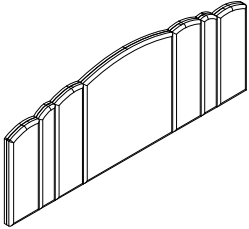
# ASSEMBLY INSTRUCTION INSTRUCTIONS DE MONTAGE

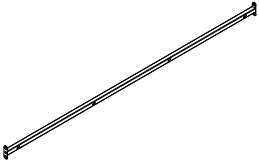
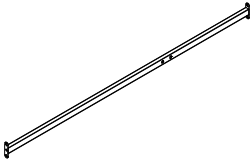
## PARTS LIST / LISTE DE PIÈCES

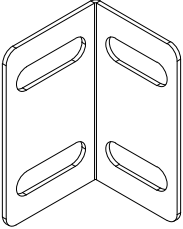
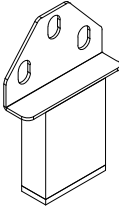
N733P208140

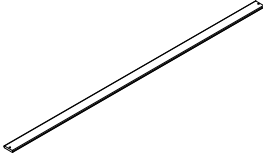
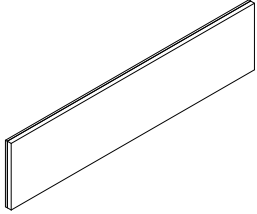
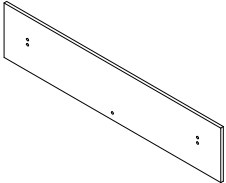
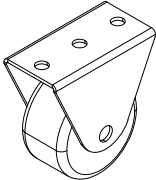
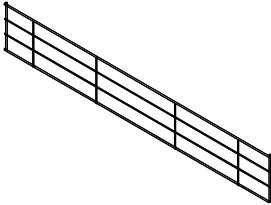
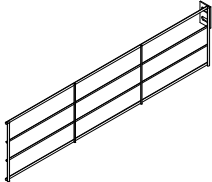
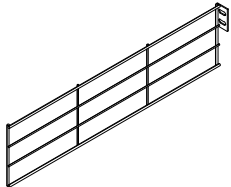
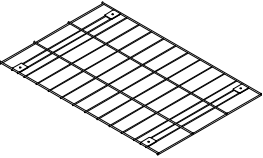
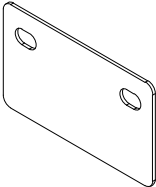
				
③*1	④*2	⑤*1	⑥*1	⑧*2
				
⑨*4	⑩*2	⑬*4	⑭*12	⑯*1
				
⑰*2	⑳*16	㉔*2	㉕*2	㉖*2
				
㉗*2	㉘*2			

# ASSEMBLY INSTRUCTION INSTRUCTIONS DE MONTAGE

## PARTS LIST / LISTE DE PIÈCES

N733P208132

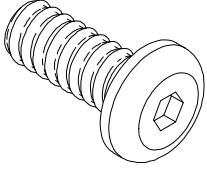
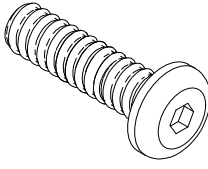
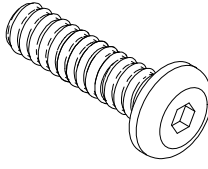
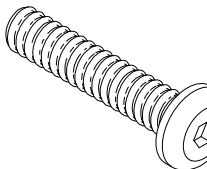
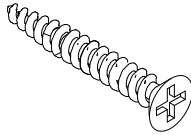
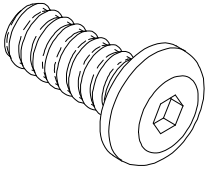
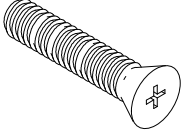
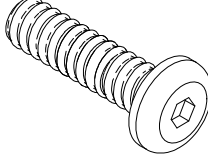
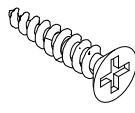
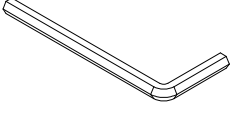
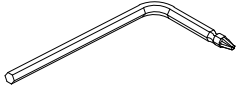
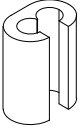
				
<b>M8*16</b> A*46	<b>M8*35</b> B*36	<b>M6*35</b> C*4	<b>M8*55</b> D*8	<b>S4*30</b> E*54
				
<b>M6*20</b> F*10	<b>M4*10</b> G*8	<b>M6*25</b> H*10	<b>S4*15</b> I*16	<b>M6</b> J*1
				
<b>M8</b> K*1	<b>L*18</b>			

Please note that the shapes of screws A and B and C and D and E and F and G and H and I are similar. Please install according to the instructions and distinguish them!

Veillez noter que les formes des vis A et B et C et D et E et F et G et H et I sont similaires. Installez-les selon les instructions et distinguez-les !

Before installation, insert the screws into the holes and tighten them, but do not tighten them to 100%, 70% to 80% is sufficient. Finally, after all screws are installed, tighten all screws to 100%. If you encounter these issues, such as if the holes cannot be aligned or some parts cannot be installed, please check if the screws are used correctly and adjust the tightness of the screws.

Insérer la vis dans le trou avant la fin de l'assemblage, serrer la vis, mais ne pas serrer à 100%, 70% ~ 80% est correct. Enfin, une fois que toutes les vis sont bien serrées, toutes les vis sont serrées à 100%. Si vous rencontrez ces problèmes, par exemple si les trous ne sont pas alignés ou si certaines pièces ne peuvent pas être montées, vérifiez que les vis sont utilisées correctement et Ajustez leur serrage.

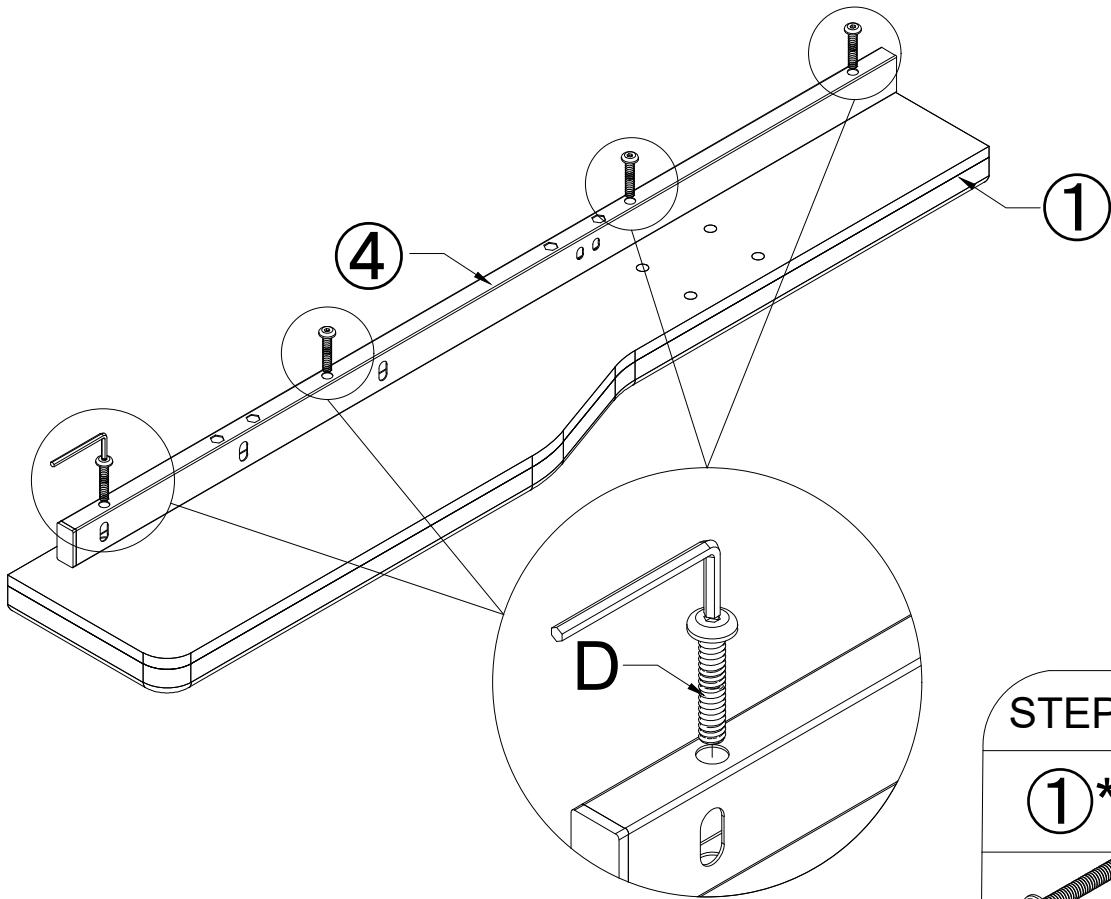

STEP 1/ÉTAPE 1

①\*1, ④\*1

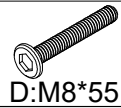

D\*4

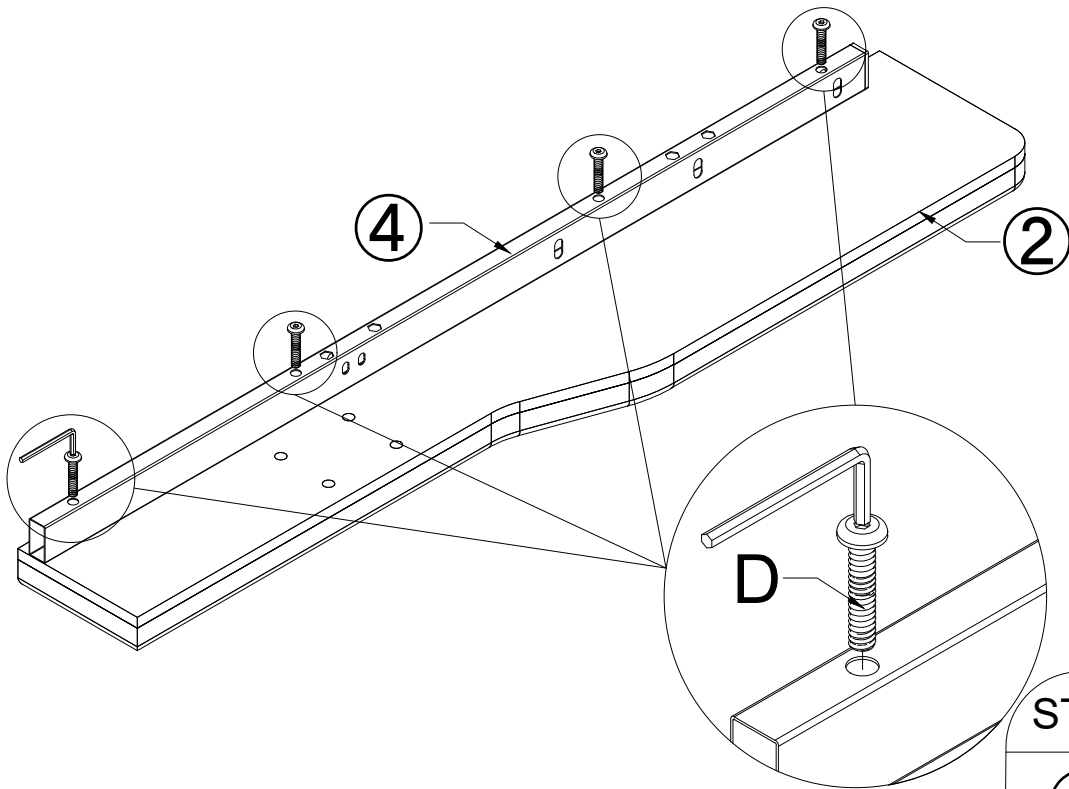

STEP 2/ÉTAPE 2

②\*1, ④\*1

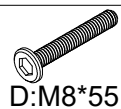

D\*4

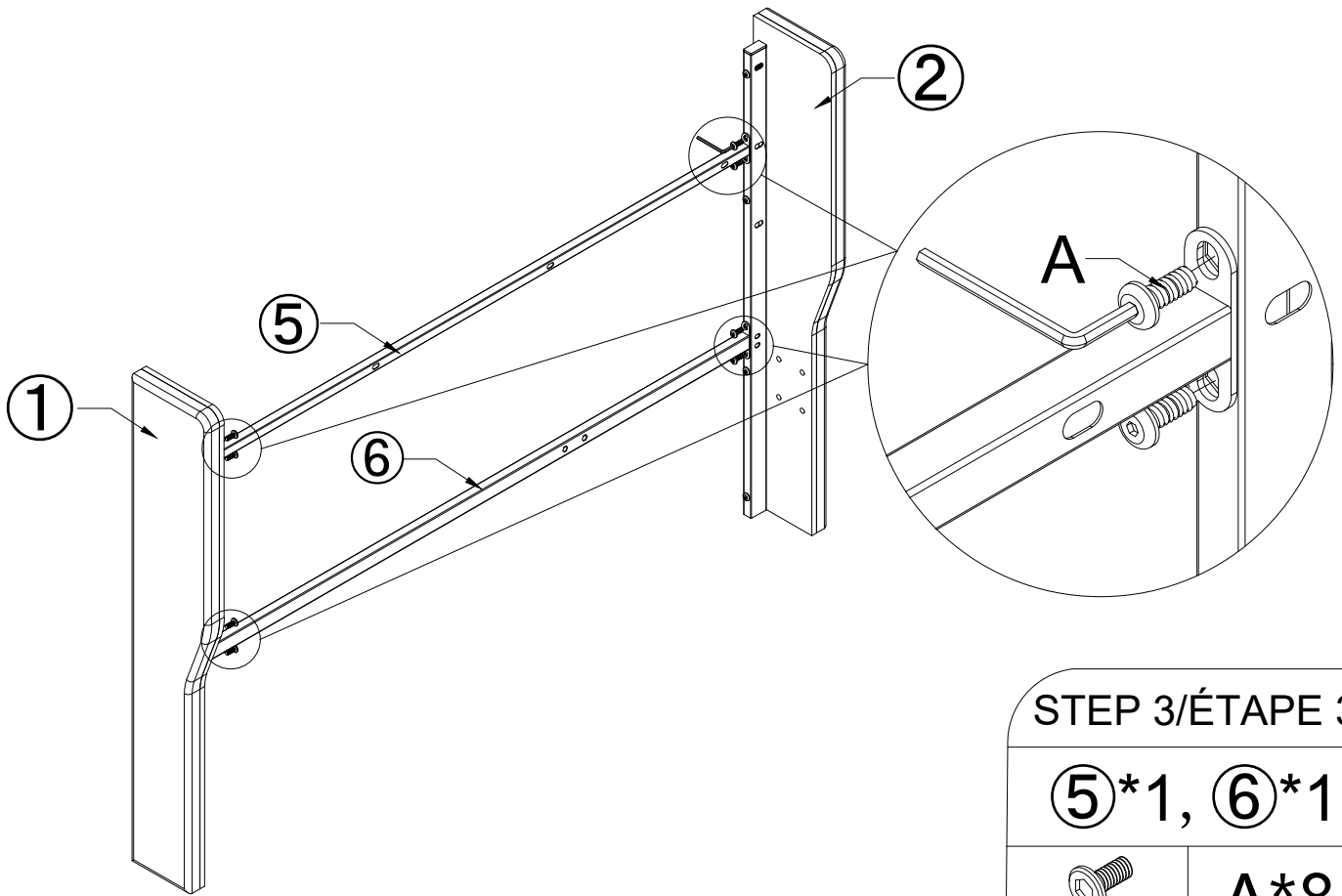

STEP 3/ÉTAPE 3

⑤\*1, ⑥\*1



A:M8\*16

A\*8

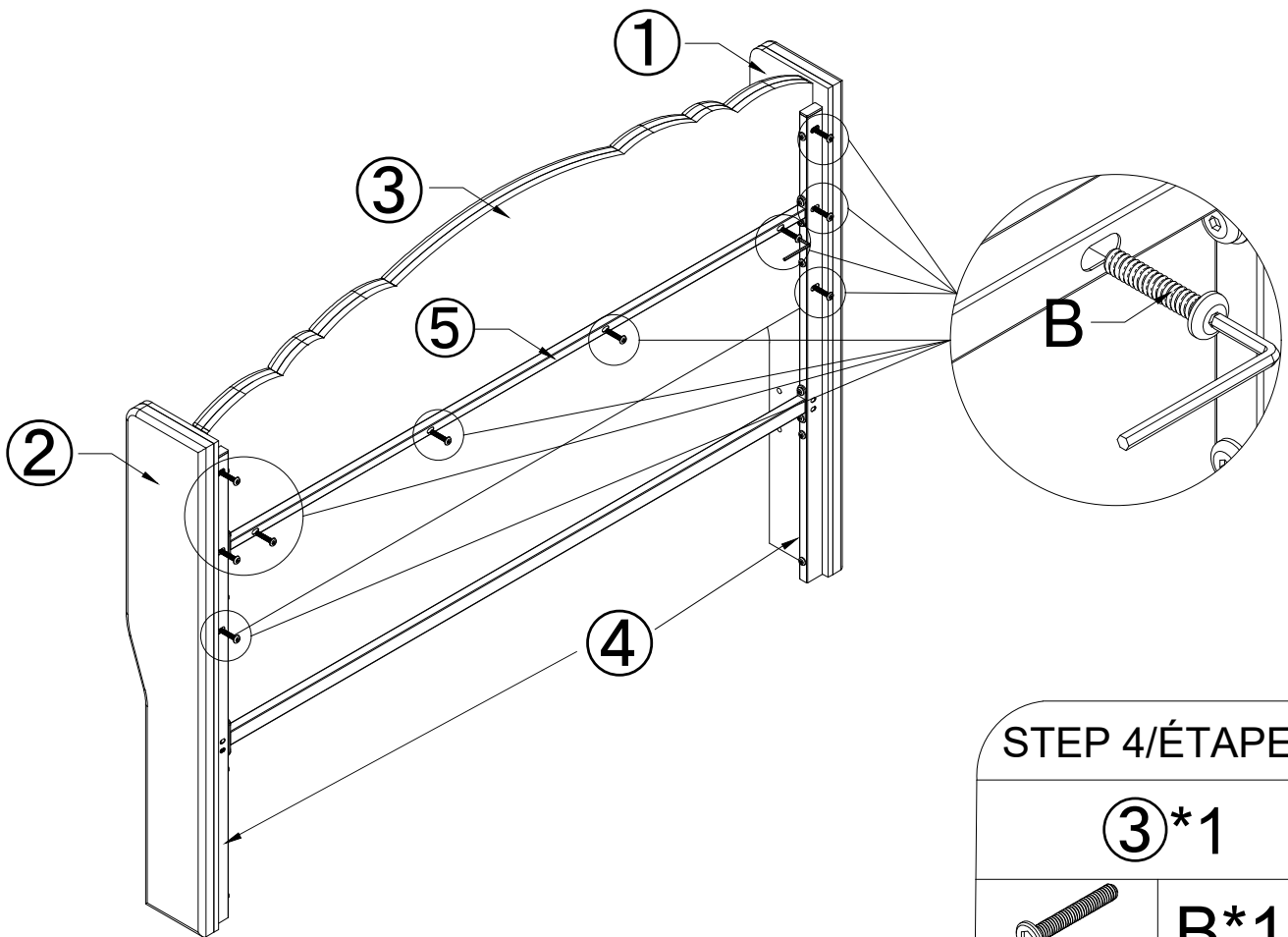

STEP 4/ÉTAPE 4

③\*1

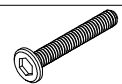

B:M8\*35

B\*10

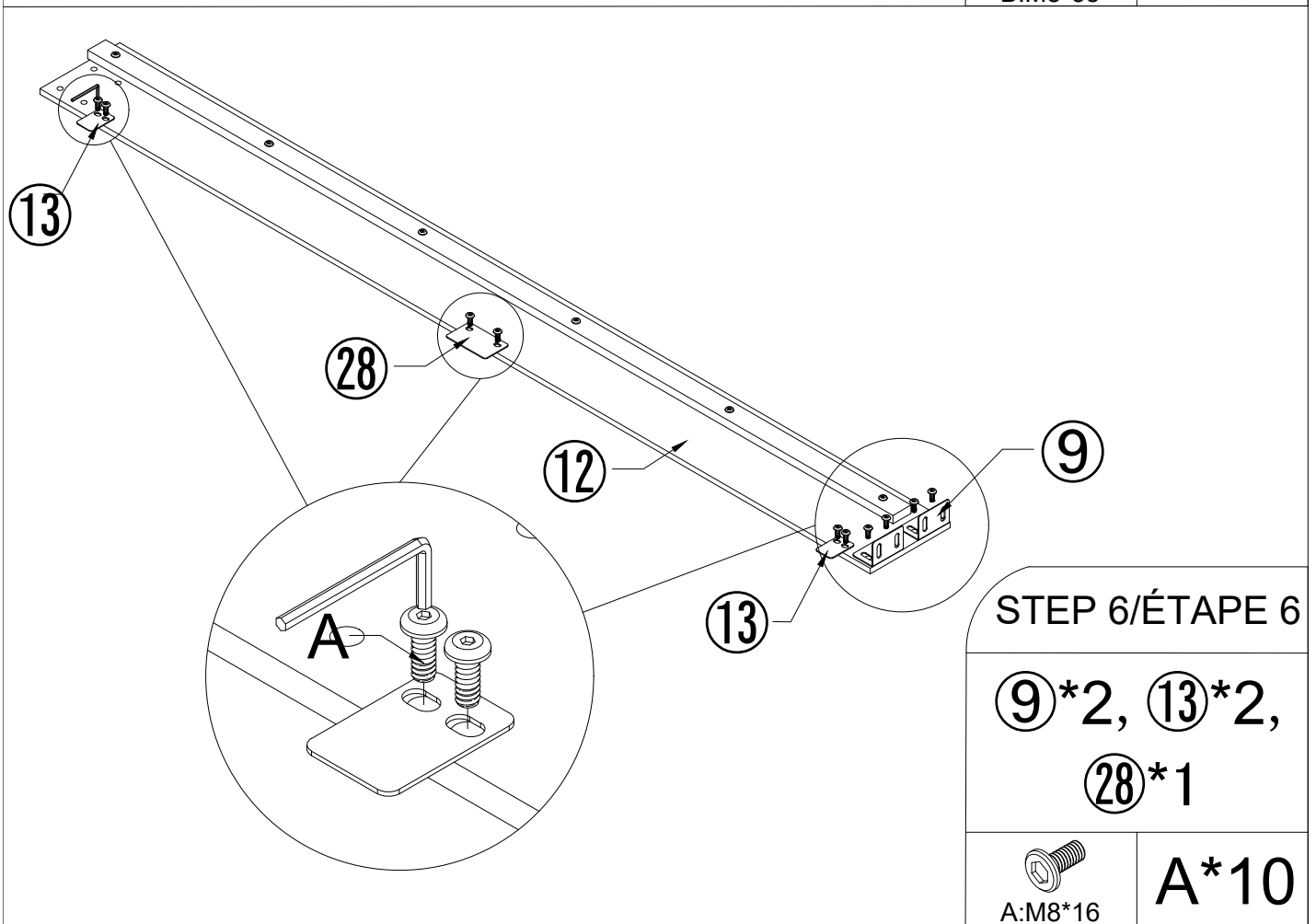
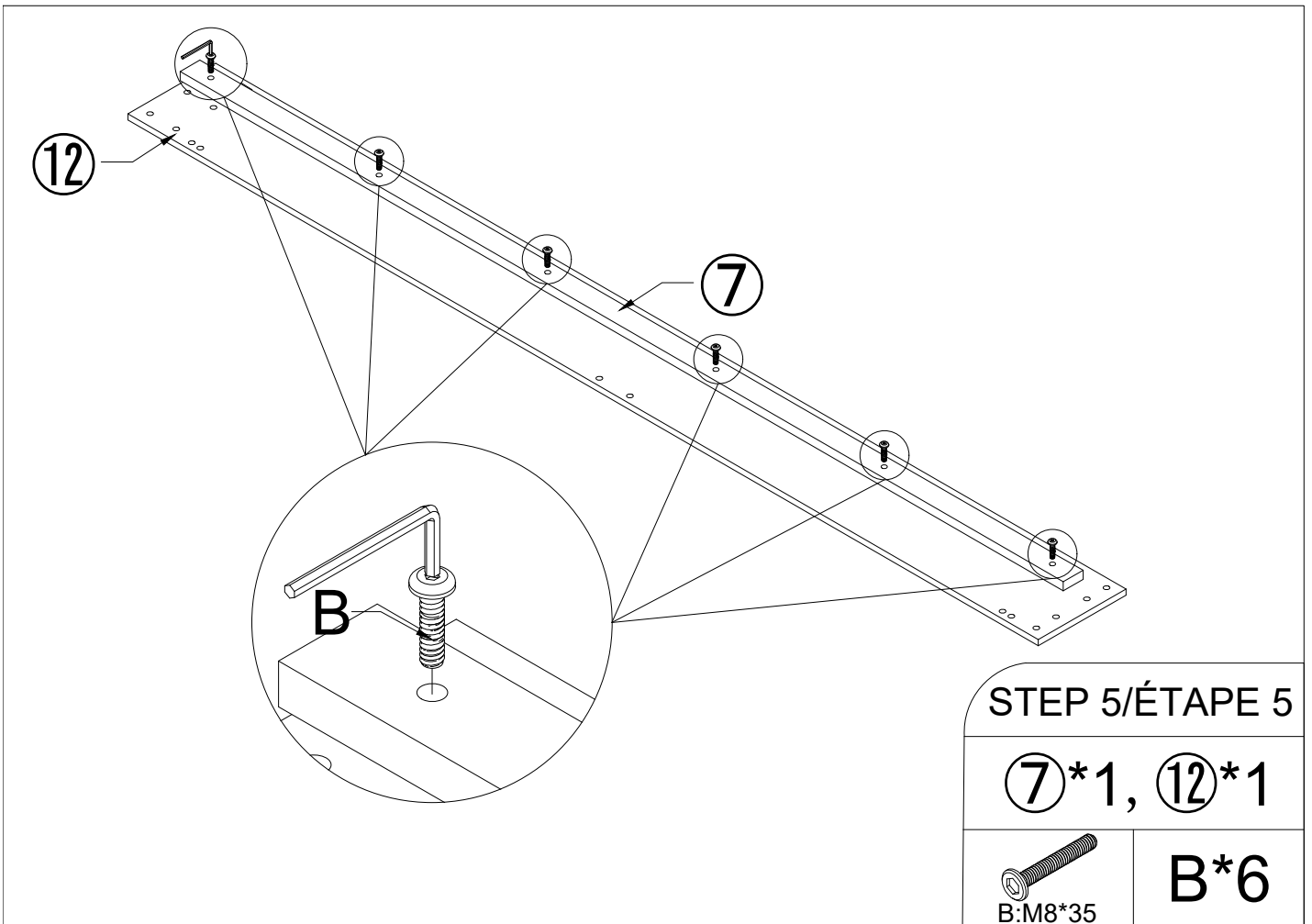

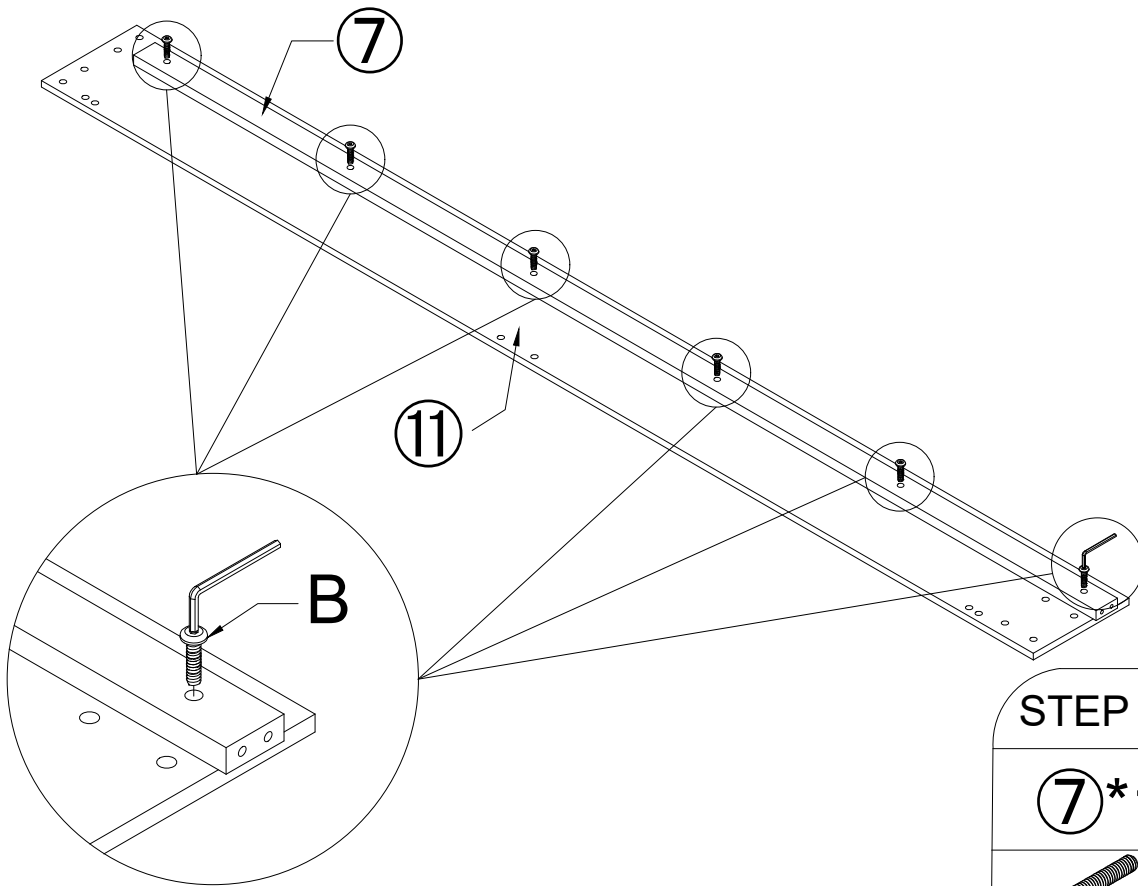

STEP 7/ÉTAPE 7

⑦\*1, ⑪\*1

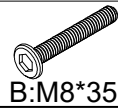

B\*6

B:M8\*35

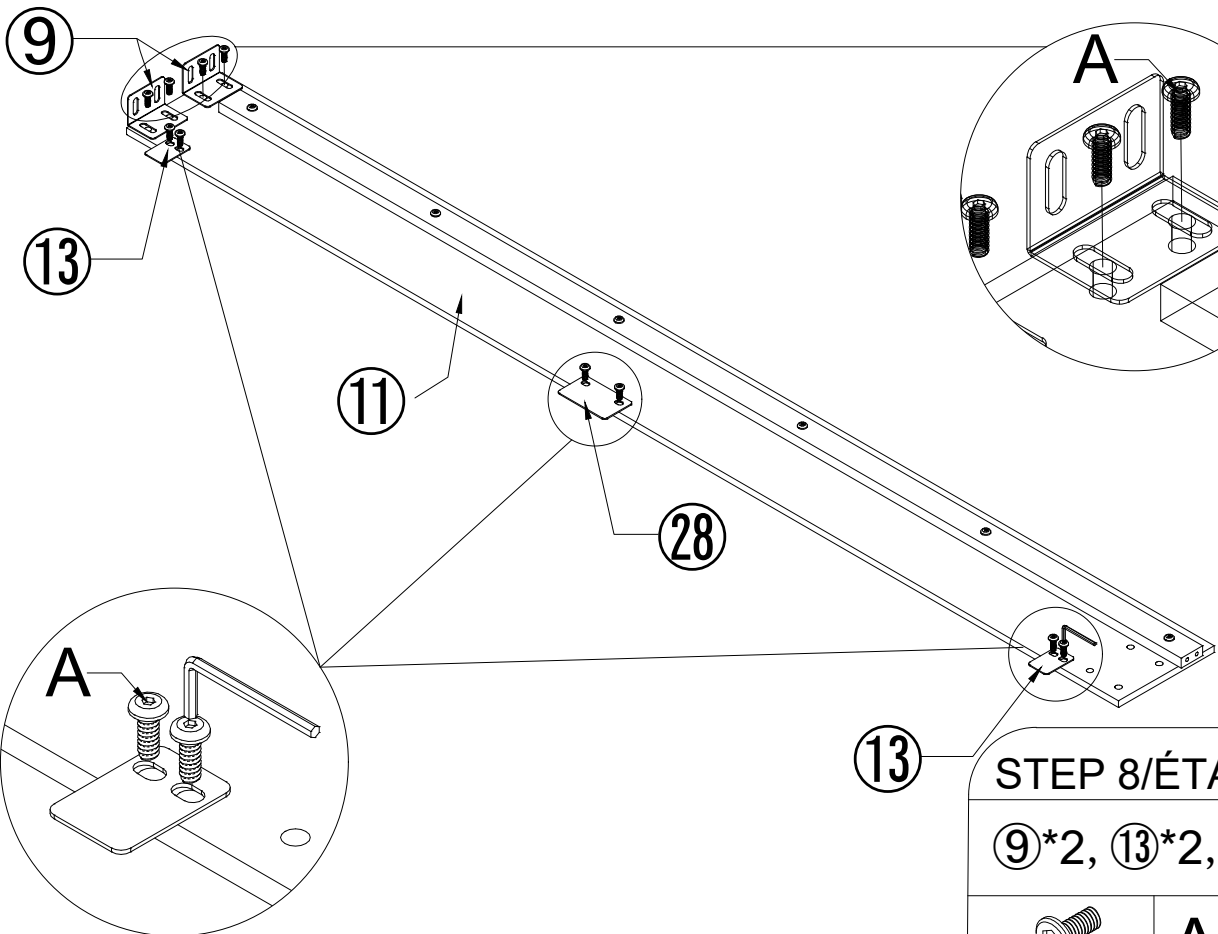

STEP 8/ÉTAPE 8

⑨\*2, ⑬\*2, ⑳\*1



A\*10

A:M8\*16

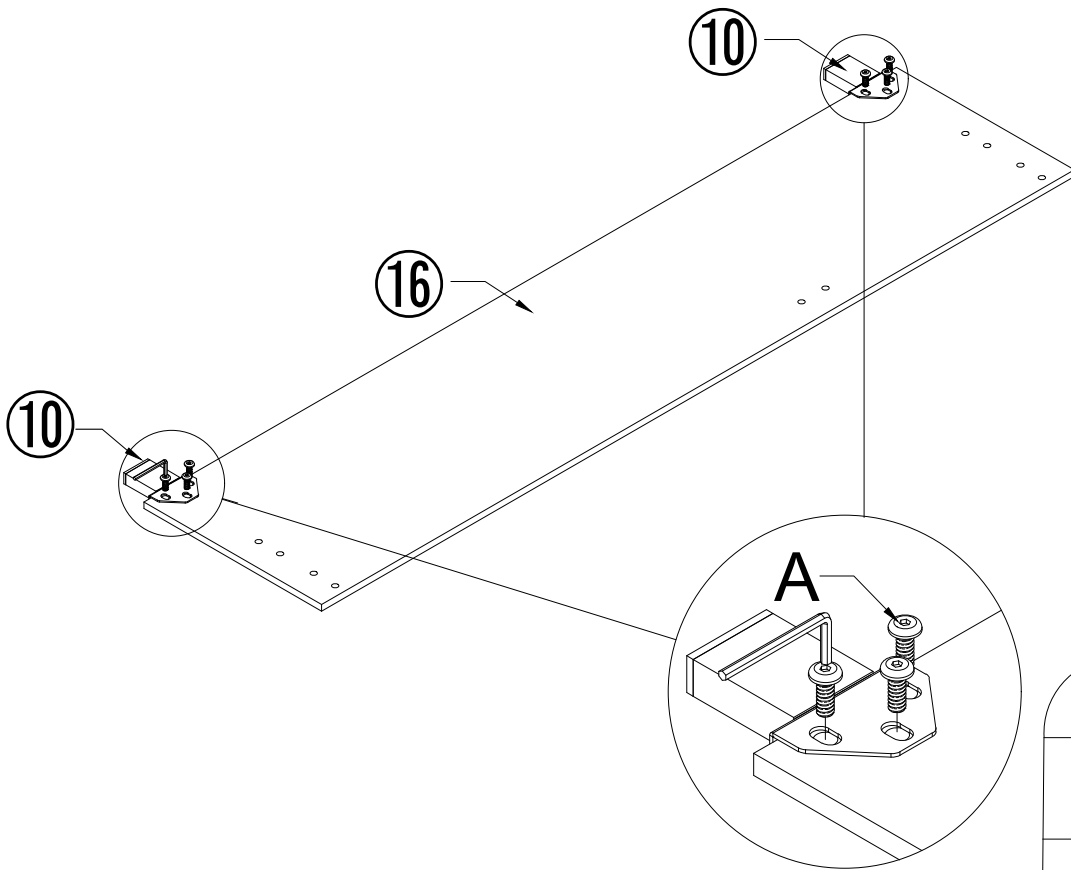

STEP 9/ÉTAPE 9

⑩\*2, ⑯\*1



A:M8\*16

A\*6

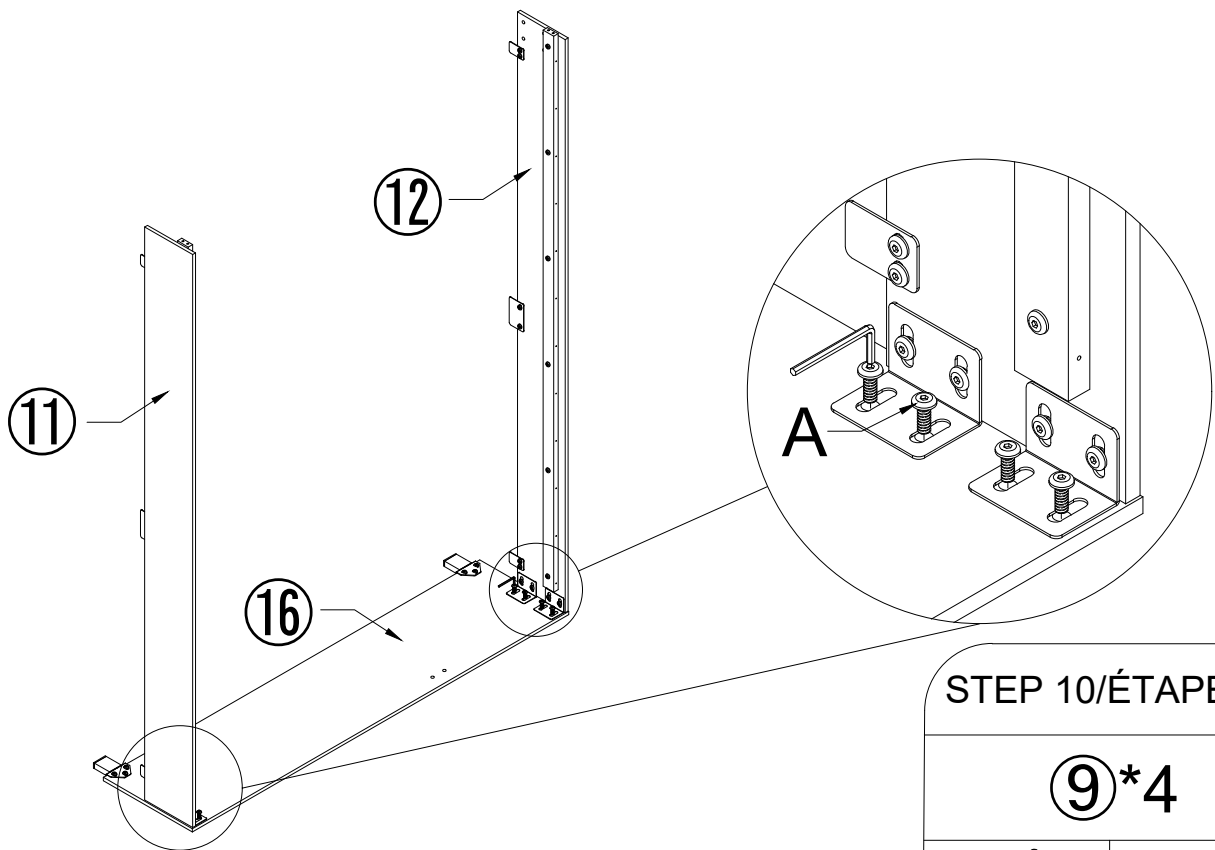

STEP 10/ÉTAPE 10

⑨\*4



A:M8\*16

A\*8

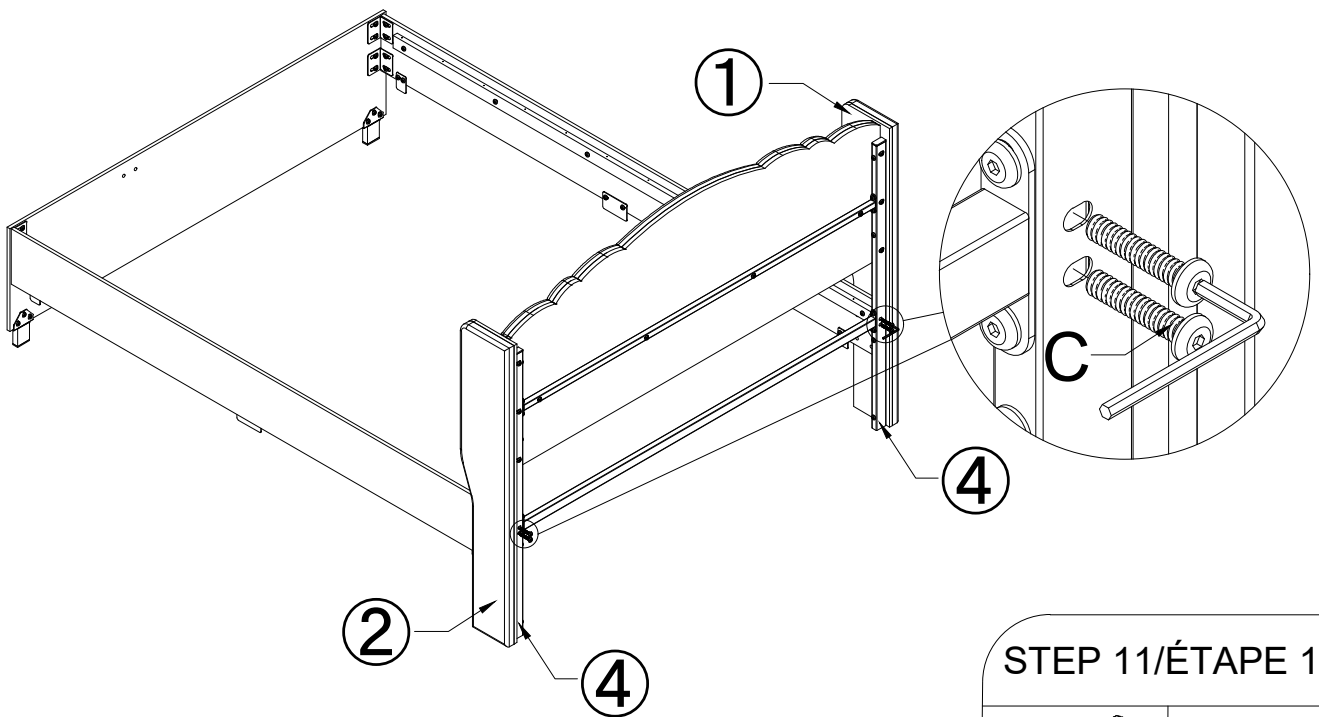

STEP 11/ÉTAPE 11



C:M6\*35

C\*4

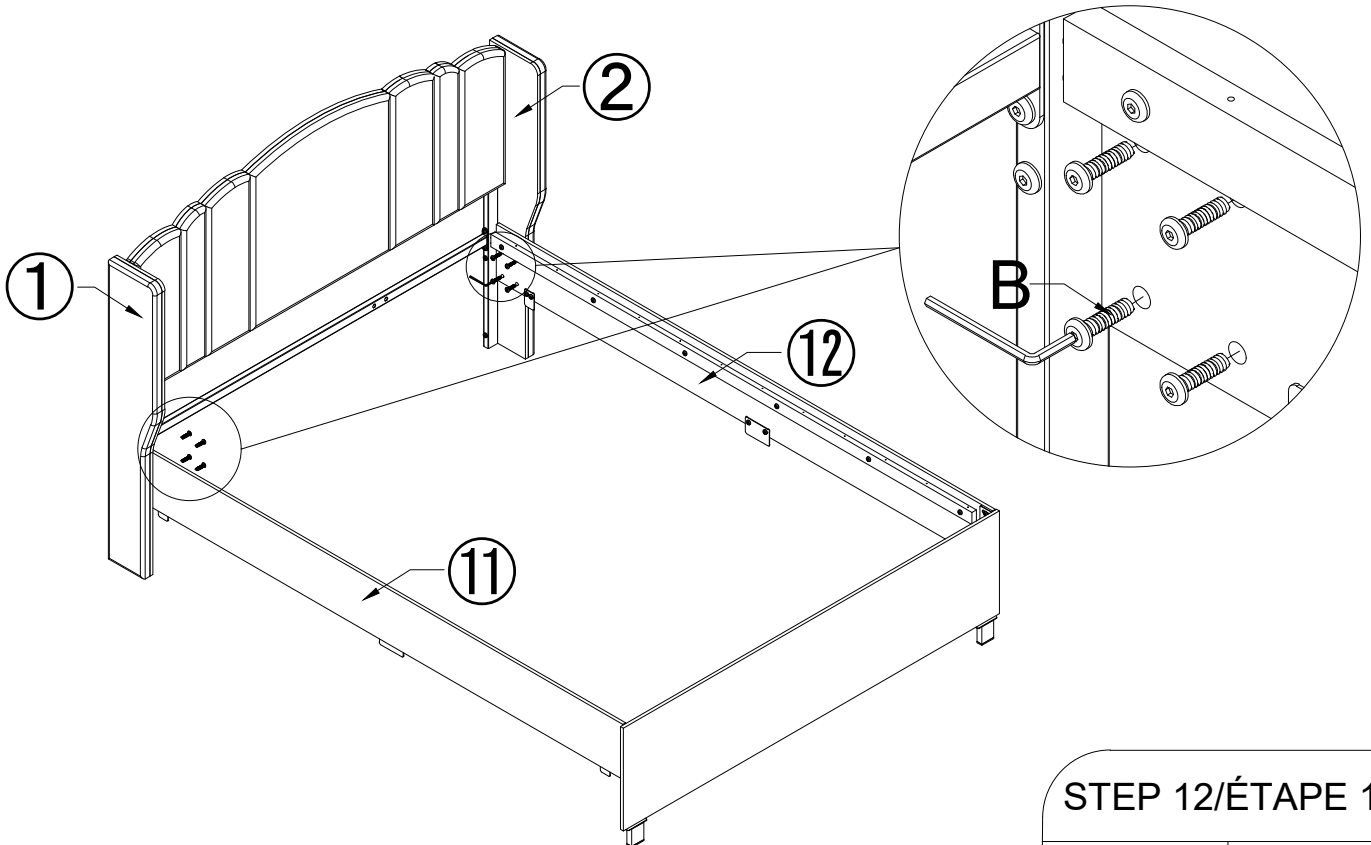

STEP 12/ÉTAPE 12



B:M8\*35

B\*8

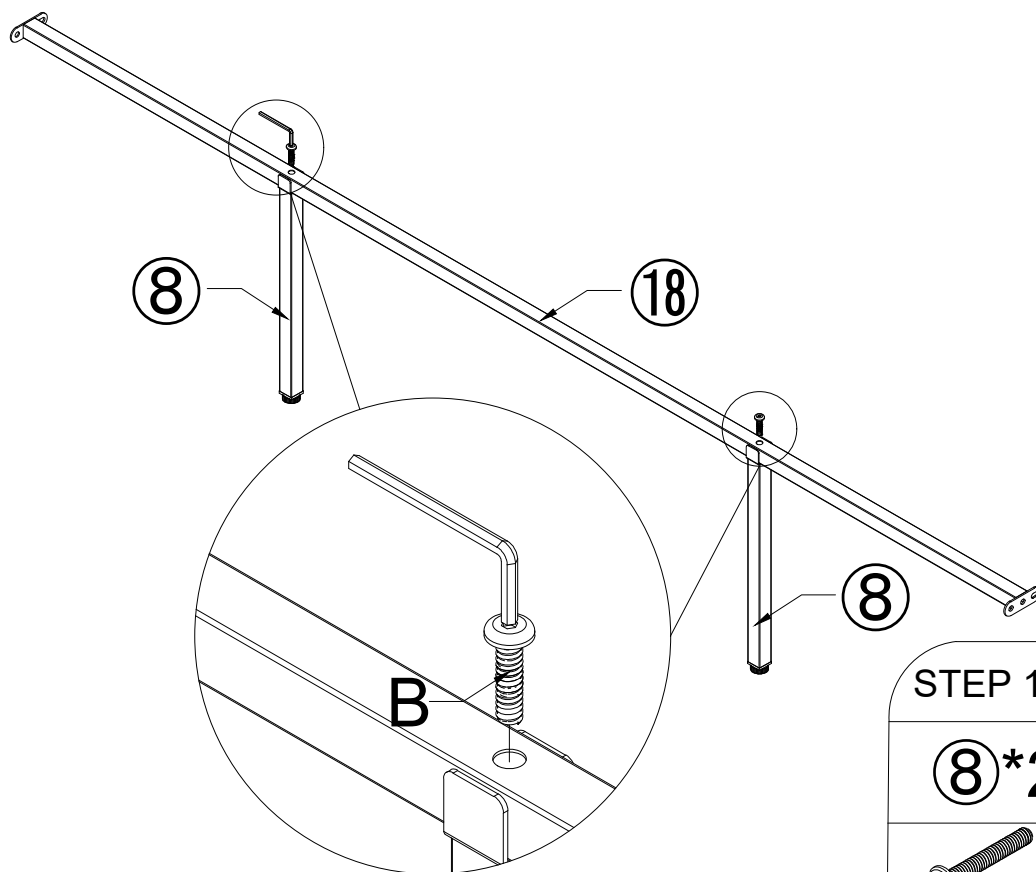

STEP 13/ÉTAPE 13

⑧\*2, ⑱\*1

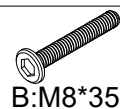

B:M8\*35

B\*2

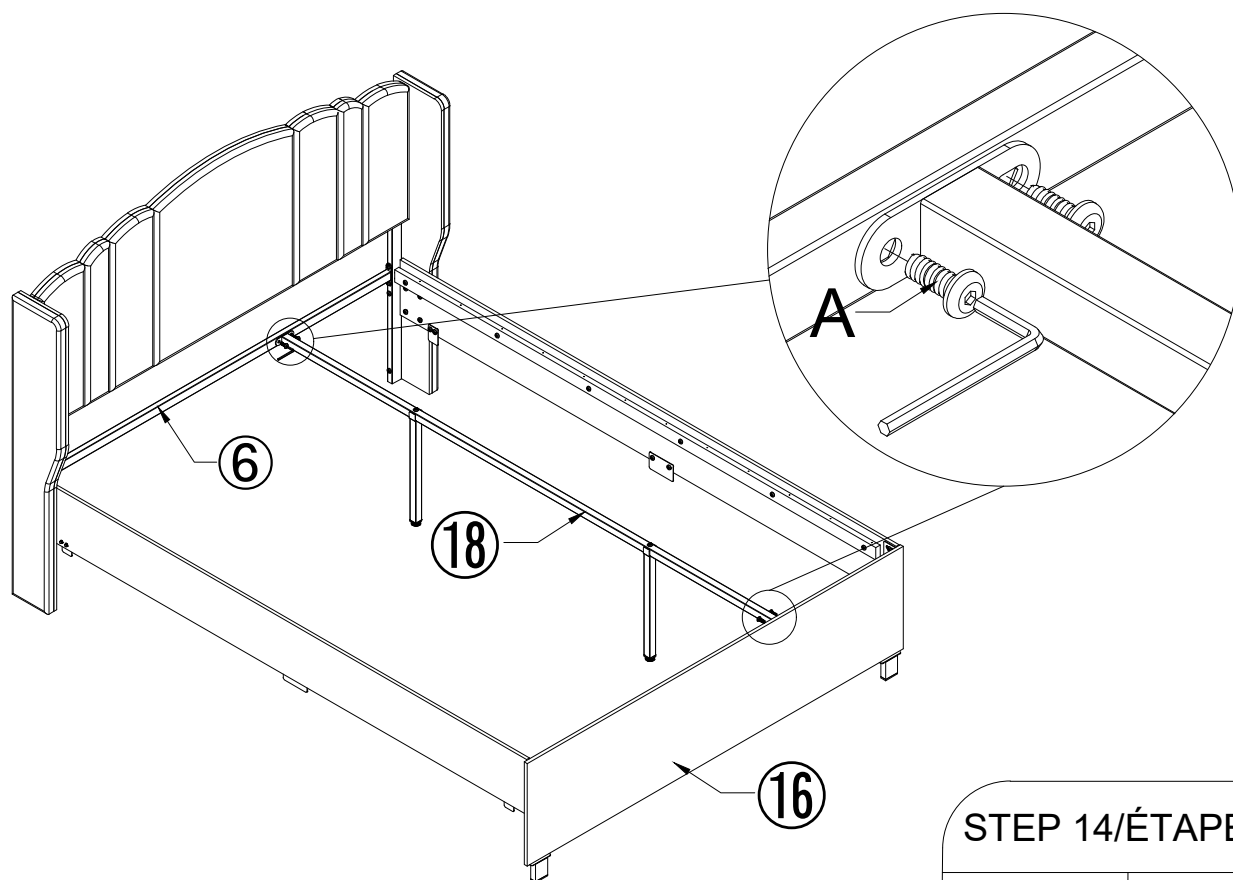

STEP 14/ÉTAPE 14



A:M8\*16

A\*4

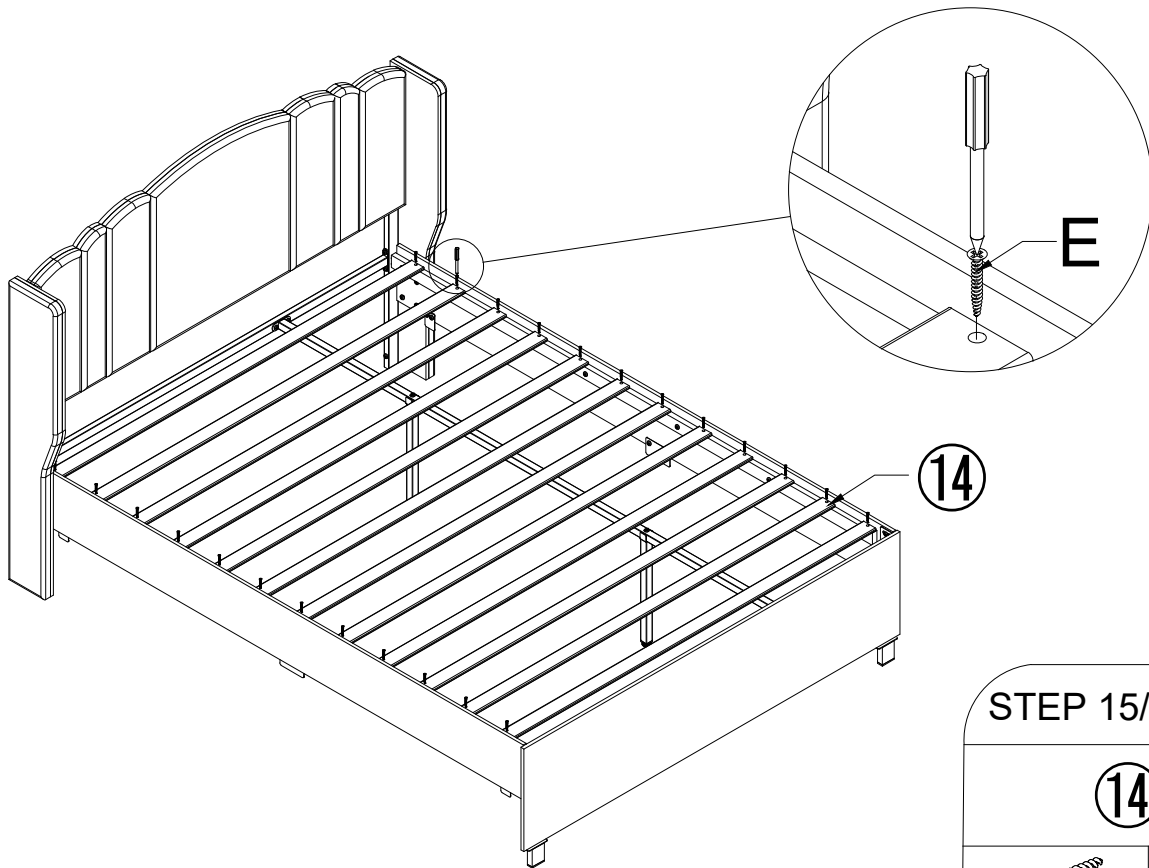

STEP 15/ÉTAPE 15

①④\*12



E\*24

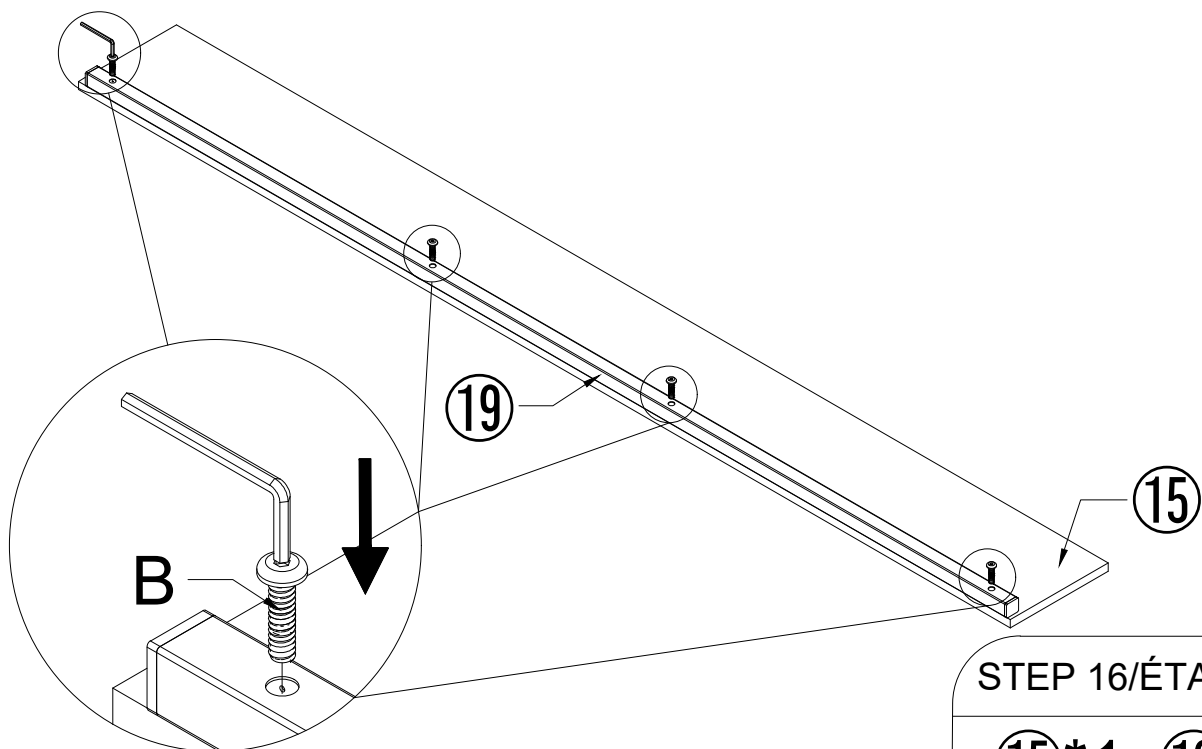

STEP 16/ÉTAPE 16

①⑤\*1, ①⑨\*1

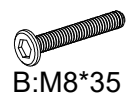

B\*4

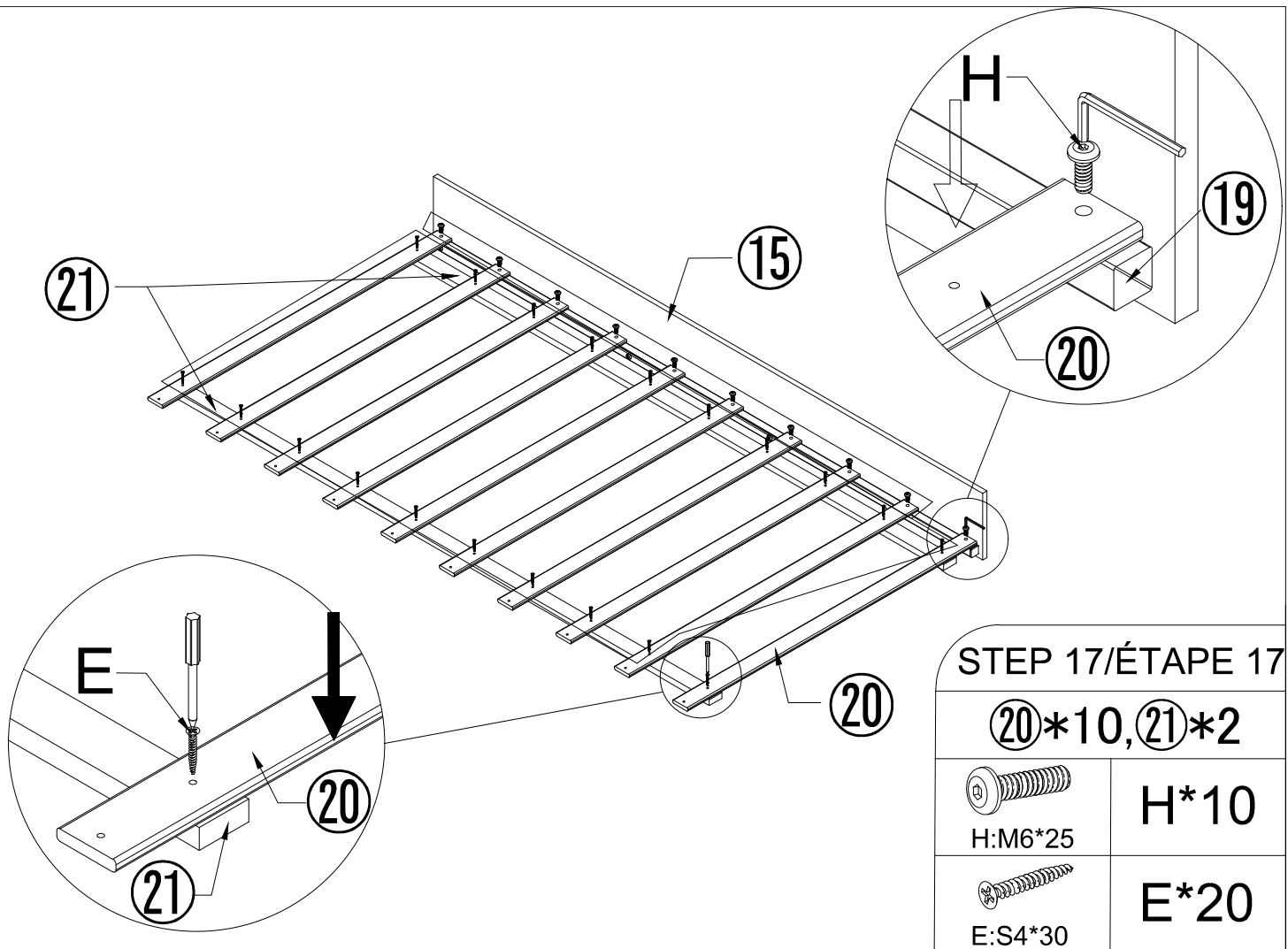

STEP 17/ÉTAPE 17

(20)\*10, (21)\*2

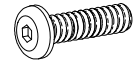

H:M6\*25

H\*10

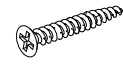

E:S4\*30

E\*20

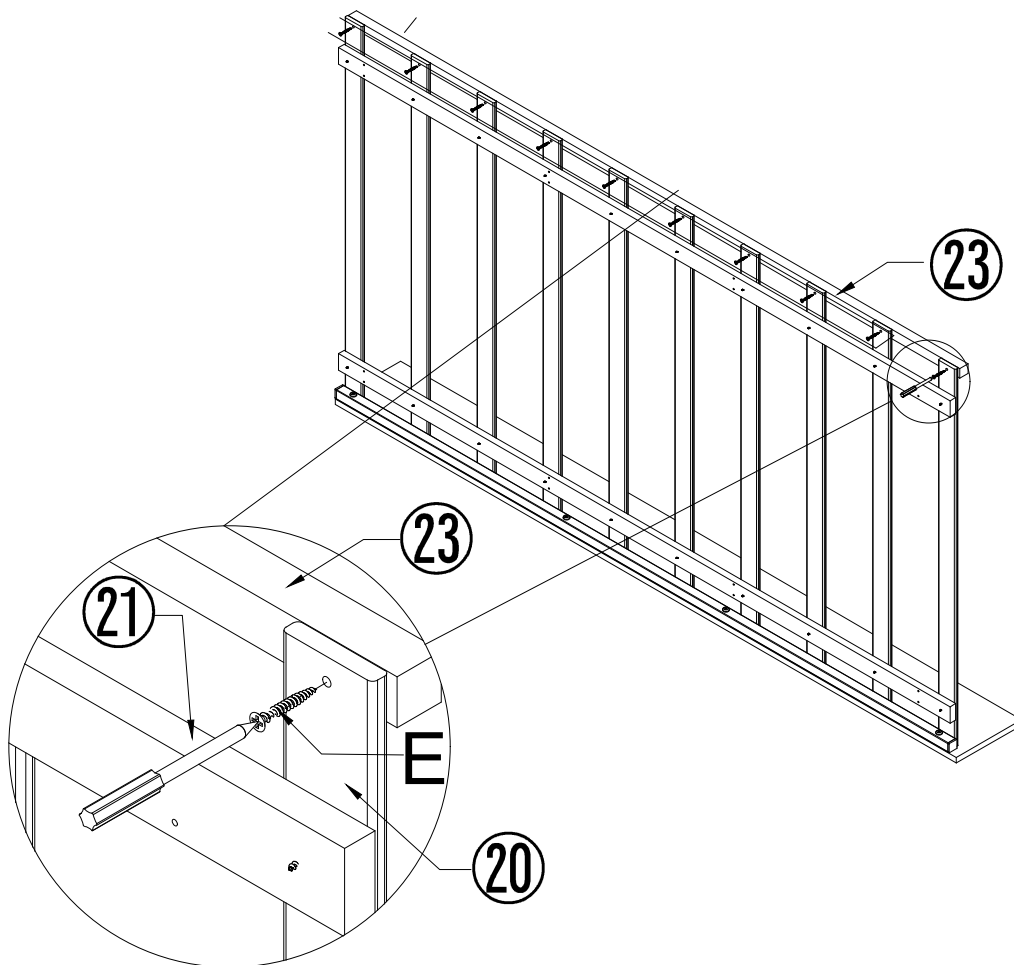

STEP 18/ÉTAPE 18

(23)\*1



E:S4\*30

E\*10

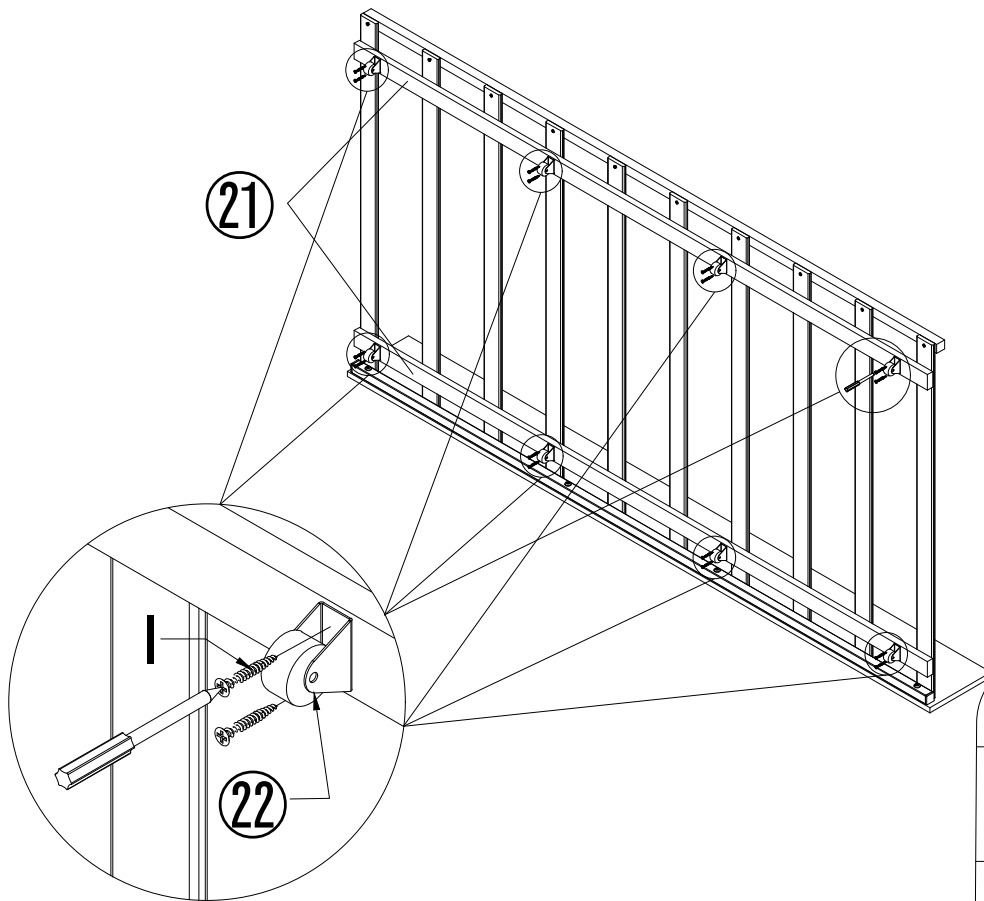

STEP 19/ÉTAPE 19	
<b>22*8</b>	
 I:S4*15	<b>I*16</b>

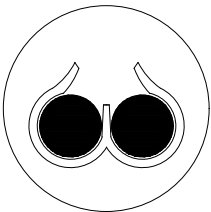
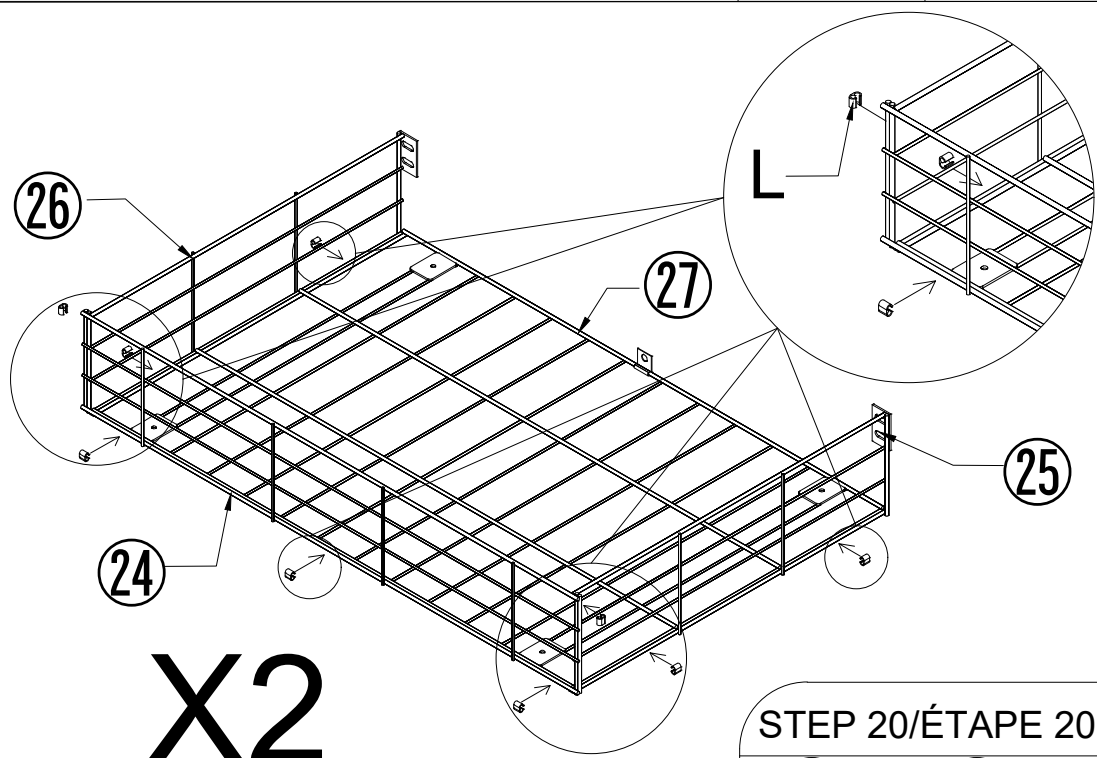

X2

STEP 20/ÉTAPE 20	
<b>24*2, 25*2</b>	
<b>26*2, 27*2</b>	
 L*18	

Embed L to the rod and make sure it is wrapped in one hole and Install 2 groups.  
 Insérez L dans la tige et assurez-vous qu'il est enroulé dans un seul trou et Installez 2 groupes.

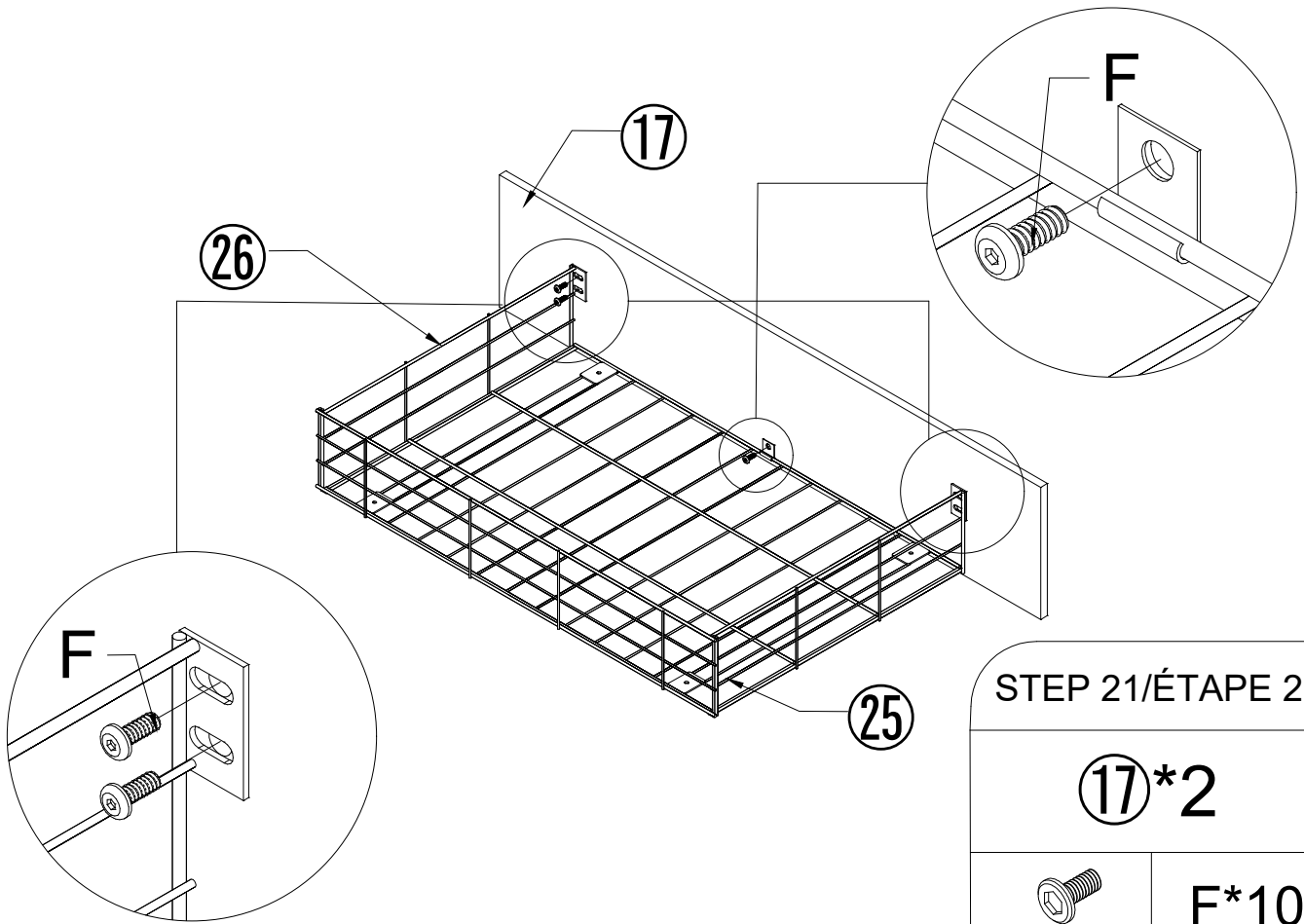

STEP 21/ÉTAPE 21

17\*2

F:M6\*20

F\*10

Install 2 groups.  
Installez 2 groupes.

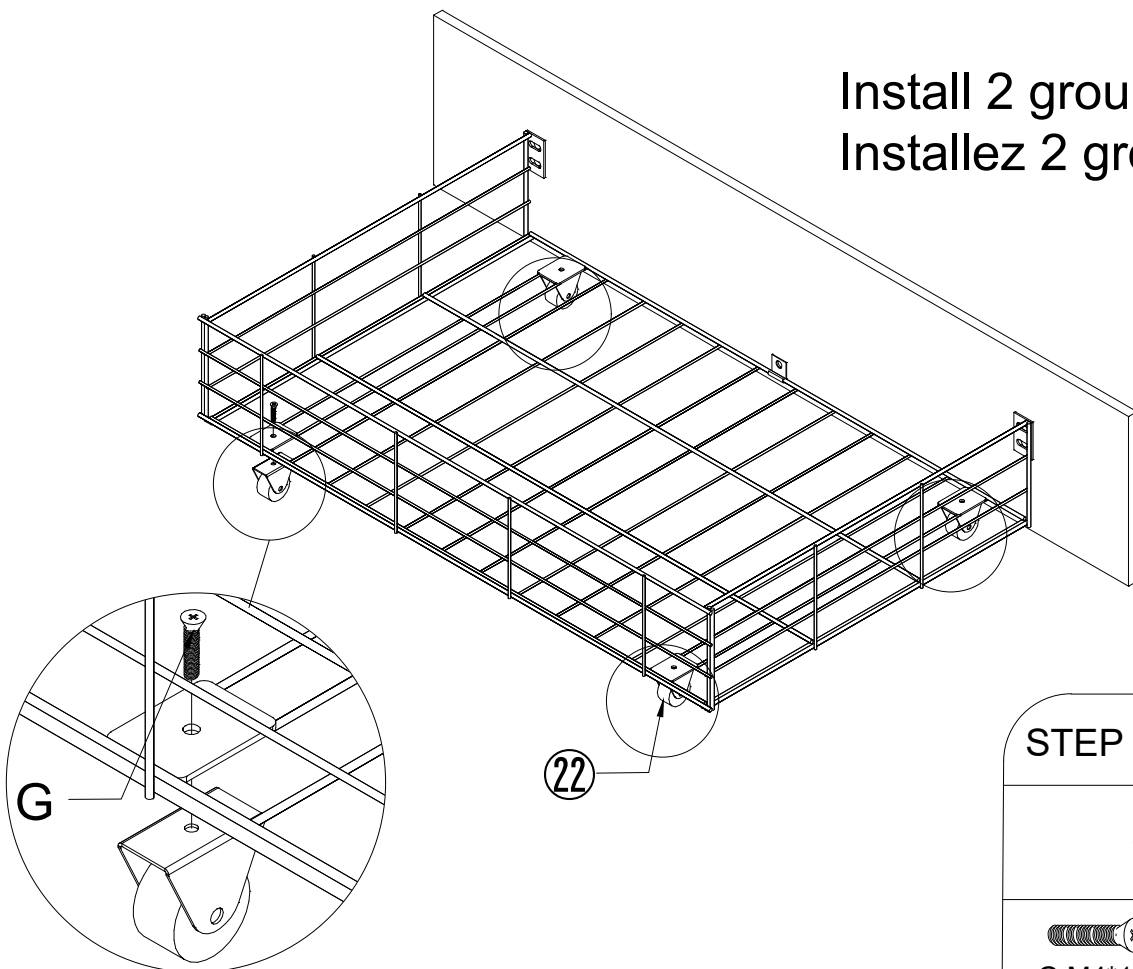

STEP 22/ÉTAPE 22

22\*8

G:M4\*10

G\*8

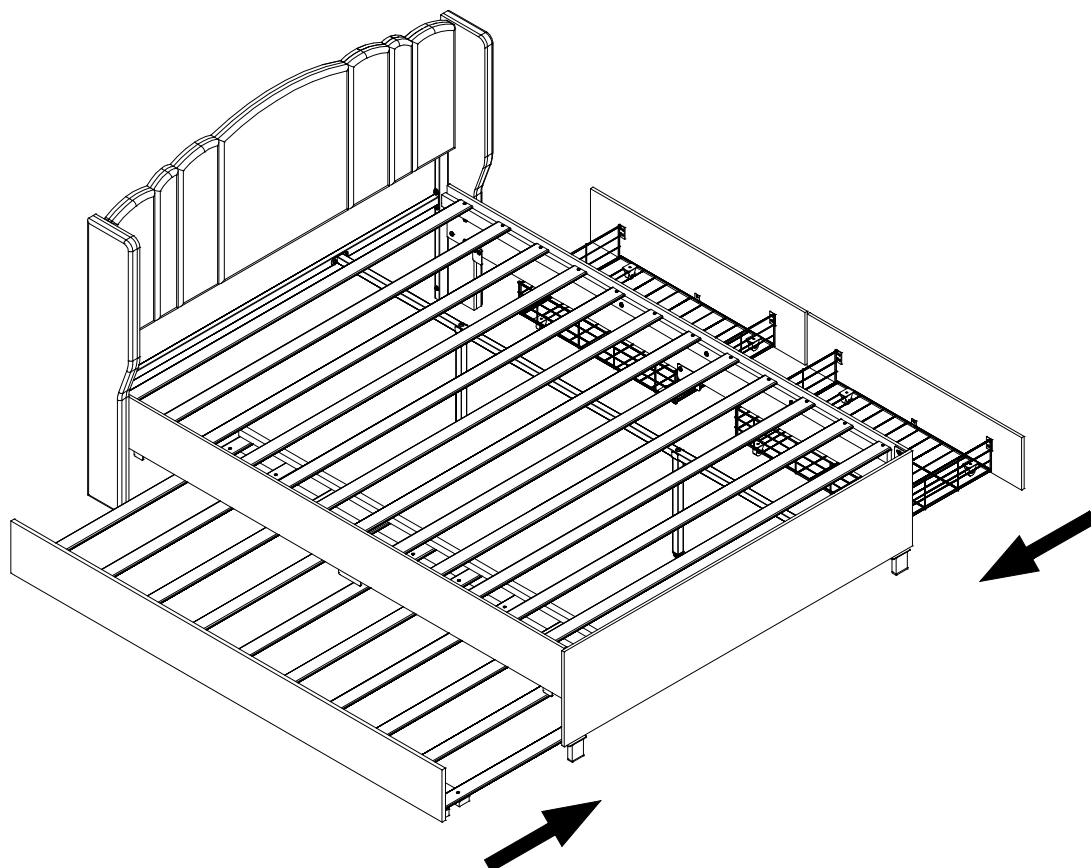

STEP 23/ÉTAPE 23

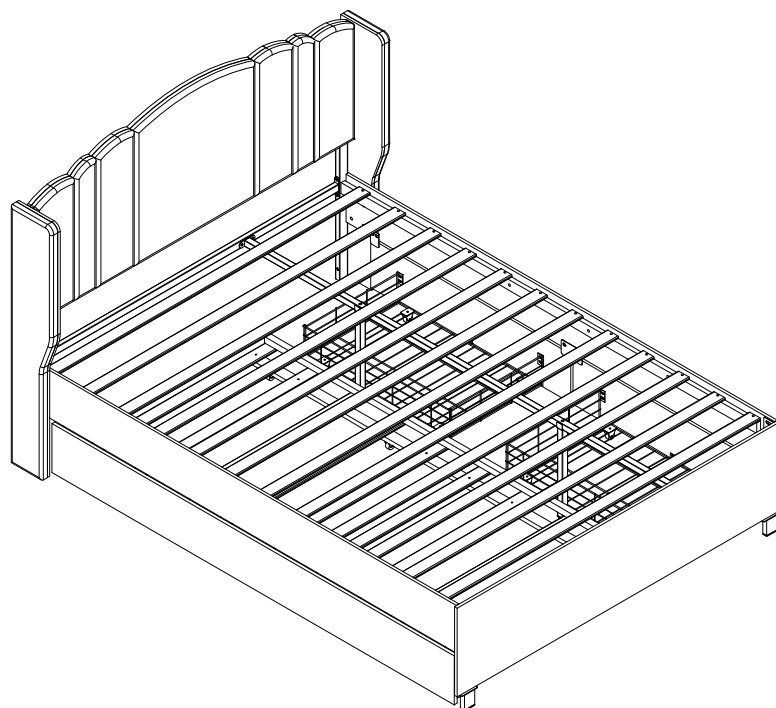

**Congratulations, installation is complete!  
Félicitations, l'installation est terminée !**