

**IMPORTANT PLEASE FOLLOW !**

After unpacking the product, keep the original packaging in case you need to return it. Before starting assembly, check that all parts and hardware are included and in good condition. If anything is missing or damaged, contact the supplier or retailer. **Do not use** non-original parts, modify the item or use power tools as this will void the warranty. Study the instructions thoroughly and follow each step carefully before proceeding to the next.

# DAKOTA 2 DOOR 1 DRAWER WARDROBE WHITE ASSEMBLY INSTRUCTIONS



LARGE SHELF  
MAX WEIGHT



HANGING RAIL  
MAX WEIGHT



MAX DRAWER  
WEIGHT

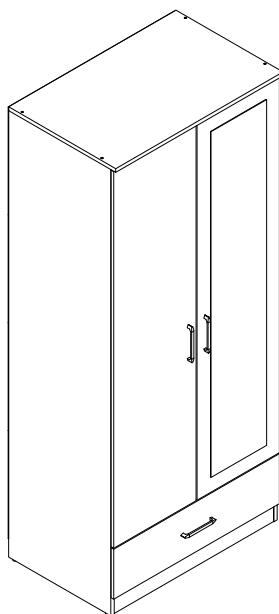

**FOR DOMESTIC USE ONLY  
FURNITURE CARE AND MAINTENANCE  
PLEASE READ BEFORE YOU CONTINUE FURTHER**

### Safety

- Keep children away from the area during assembly for safety.
- Use a blanket or sheet on the floor during assembly to protect both the product and your flooring.
- Attach the Anti-Tip strap shown on the final step to the wall. This will prevent the item from tipping over and causing damage or serious injury.
- Follow all recommended weight limits as shown on the assembly instructions.

### Care

- Avoid dragging or pushing the product, as this may damage the joints and weaken the structure.
- Avoid prolonged exposure to direct sunlight, which can cause fading, discolouration, or drying of natural wood.
- Maintain stable room temperature and humidity, as extreme heat, cold, or moisture may lead to warping, cracking, or swelling.
- Protect the surface from hot or cold items by using placemat's or coasters.
- Please avoid attaching anything sticky to the item, such as Sellotape, stickers, or similar materials, as this can damage the finish.
- Use felt pads under décor, lamps and accessories to prevent scratches.
- Clean spills immediately, blotting rather than rubbing to prevent spreading and surface damage.

### Maintenance

- Periodically tighten all fittings to ensure the furniture remains stable and secure.
- Use only a damp cloth followed by a dry cloth for routine cleaning - avoid detergents, solvents and chemical cleaner.

## TOOLS REQUIRED

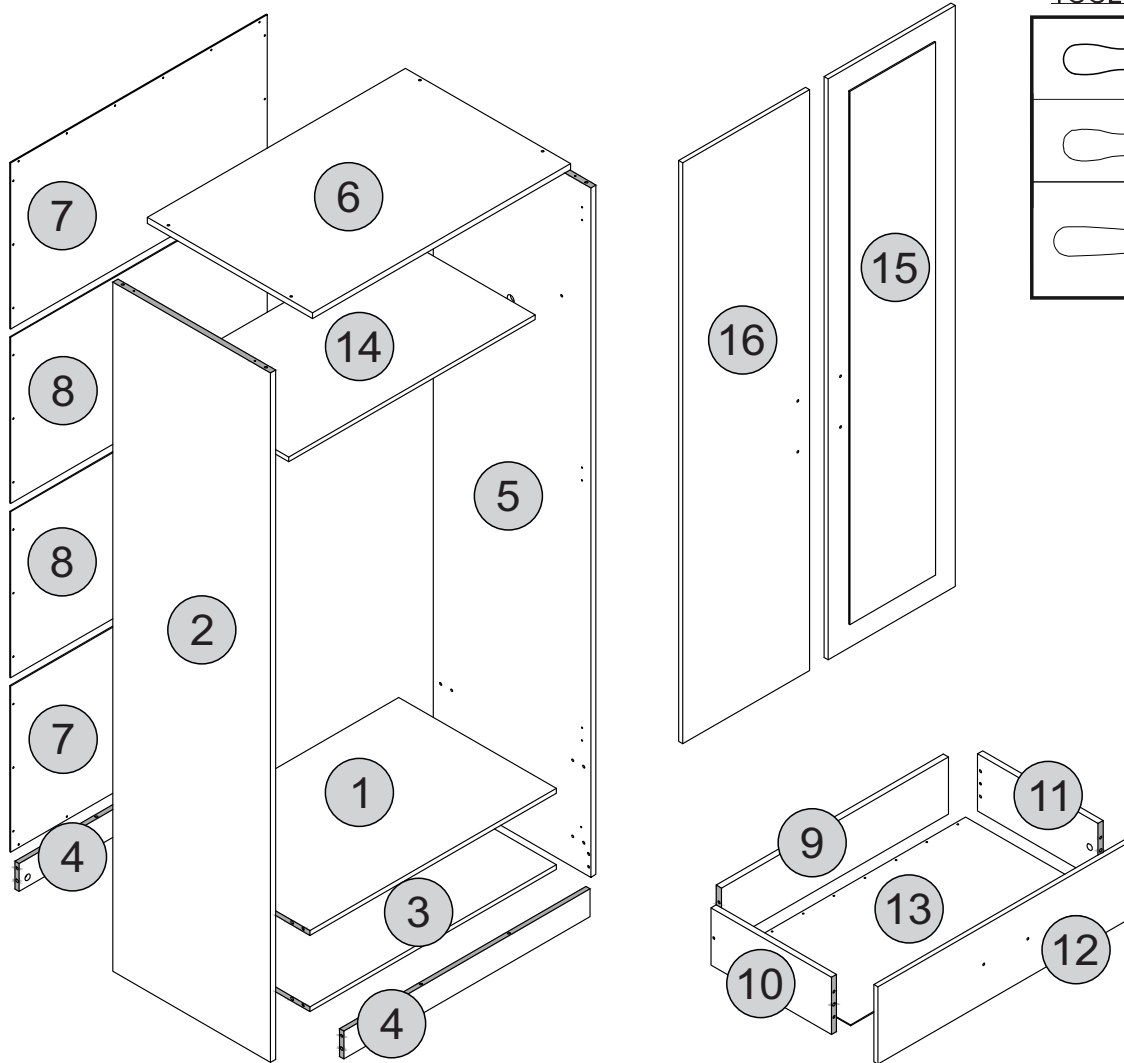
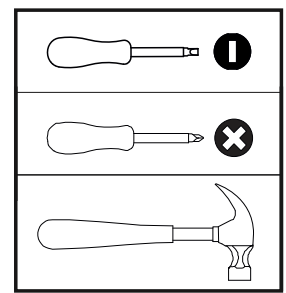











**PART LIST****Carton 1 of 2**

Part Number	Part Code	Part Description	Quantity	Carton
2	S100-101-262-EU1-02	Side Panel - Left	1	1/2
5	S100-101-262-EU1-05	Side Panel - Right	1	1/2
15	S100-101-262-EU1-15	Mirrored Door - Right	1	1/2
16	S100-101-262-EU1-16	Door - Left	1	1/2

**Carton 2 of 2**

1	S100-101-262-EU1-01	Shelf Panel 1	1	2/2
3	S100-101-262-EU1-03	Bottom Panel	1	2/2
4	S100-101-262-EU1-04	Bottom Apron	2	2/2
6	S100-101-262-EU1-06	Top Panel	1	2/2
7	S100-101-262-EU1-07	Back Panel 1	2	2/2
8	S100-101-262-EU1-08	Back Panel 2	2	2/2
9	S100-101-262-EU1-09	Drawer Back	1	2/2
10	S100-101-262-EU1-10	Drawer Side - Left	1	2/2
11	S100-101-262-EU1-11	Drawer Side - Right	1	2/2
12	S100-101-262-EU1-12	Drawer Front	1	2/2
13	S100-101-262-EU1-13	Drawer Base	1	2/2
14	S100-101-262-EU1-14	Shelf Panel 2	1	2/2

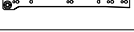
## HARDWARE LIST

A		DOWEL 6 X 30MM	28 PCS
B		SCREW M4 X 50MM	4 PCS
C		SCREW M3.5 X 16MM	7 PCS
D		CAM BOLT + CAM NUT	14 SETS
E		HANDLE	3 PCS
F		HANDLE SCREW 16MM	6 PCS
G		TACK	44 PCS
H		SCREW M3.5 X 12MM	20 PCS
I		STOPPER	1 PC
J		PLASTIC H STRIP	3 PCS
K		PLASTIC FOOT	4 PCS
L		SHELF SUPPORT	4 PCS
M		HINGES	6 PCS
N		TAPPING SCREW M8 X 12MM	12 PCS
O		HANGING RAIL	1 PC
P		PLASTIC CORNER BLOCK	2 PCS
Q		DRAWER RUNNER A - L/R	2 PCS
R		DRAWER RUNNER B - L/R	2 PCS
S		SCREW M4 X 38MM	2 PCS
T		ANTI - TIP STRAP	2 PCS
U		SCREW M4 X 16MM	2 PCS

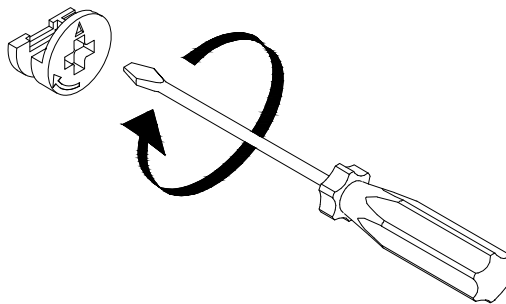

(SCREWDRIVER NOT PROVIDED)

USE A FLAT HEAD SCREWDRIVER TO TIGHTEN THE CAM NUTS. A QUARTER TURN CLOCKWISE IS ALL THAT IS NEEDED.

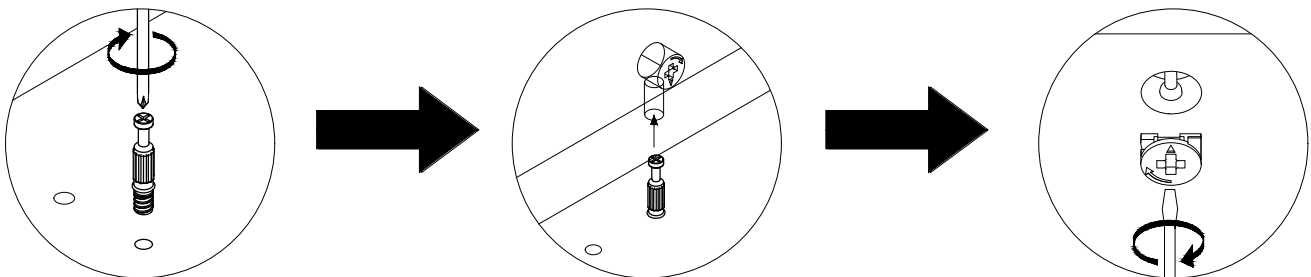

STEP 1 - USE A CROSS SLOT SCREWDRIVER TO TIGHTEN THE CAM BOLT INTO THE HOLE.

STEP 2 - ALIGN THE CAM BOLT WITH THE HOLE AND PUSH TOGETHER UNTIL FLUSH. ( MAKE SURE THE ARROW OF THE CAM LOCK IS POINTING TOWARD THE EDGE OF THE PANEL.)





STEP 3 - THE HEAD OF THE BOLT GOES INTO THE WIDE MOUTH OF THE CAM LOCK. YOU THEN TURN THE LOCK SO THE NARROW PART CLOSES OVER THE BOLT.

# STEP 1

**PARTS REQUIRED**

1 - SHELF PANEL 1	x1
6 - TOP PANEL	x1

**HARDWARE REQUIRED**

A		04
C		01
D		04
I		01

**TOOLS REQUIRED**

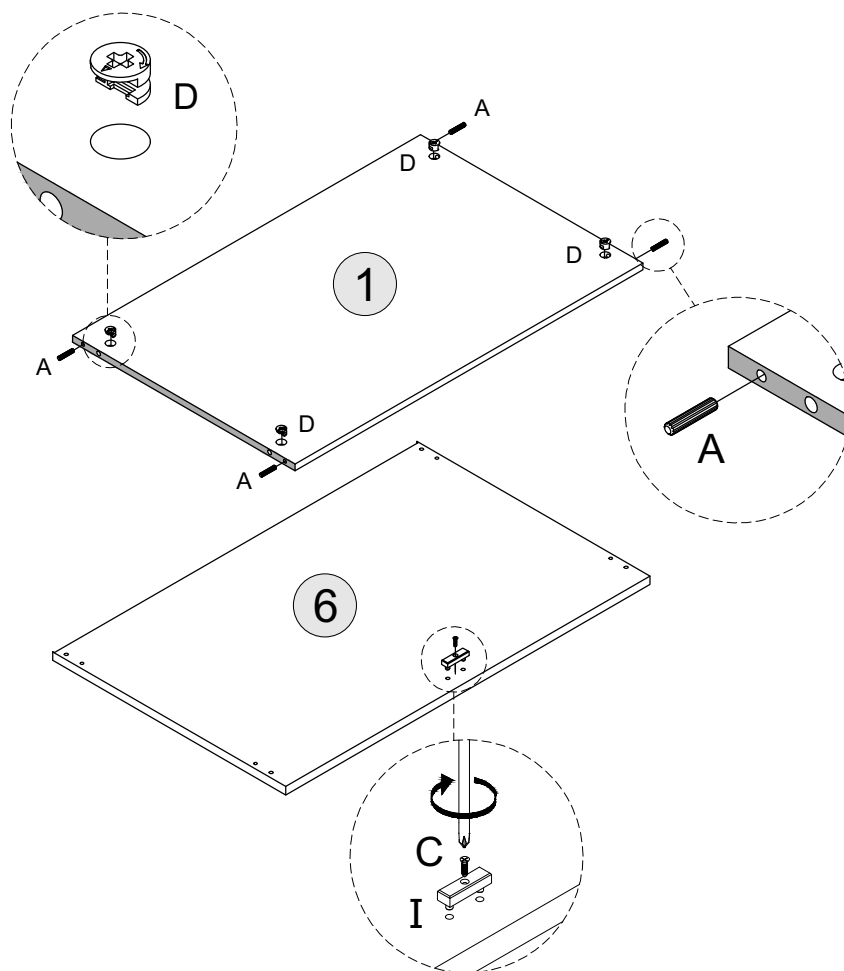
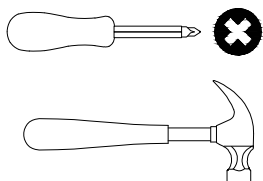



# STEP 2

**PARTS REQUIRED**

3 - BOTTOM PANEL	x1
4 - BASE APRON	x2

**HARDWARE REQUIRED**

A		12
D		08

**TOOLS REQUIRED**

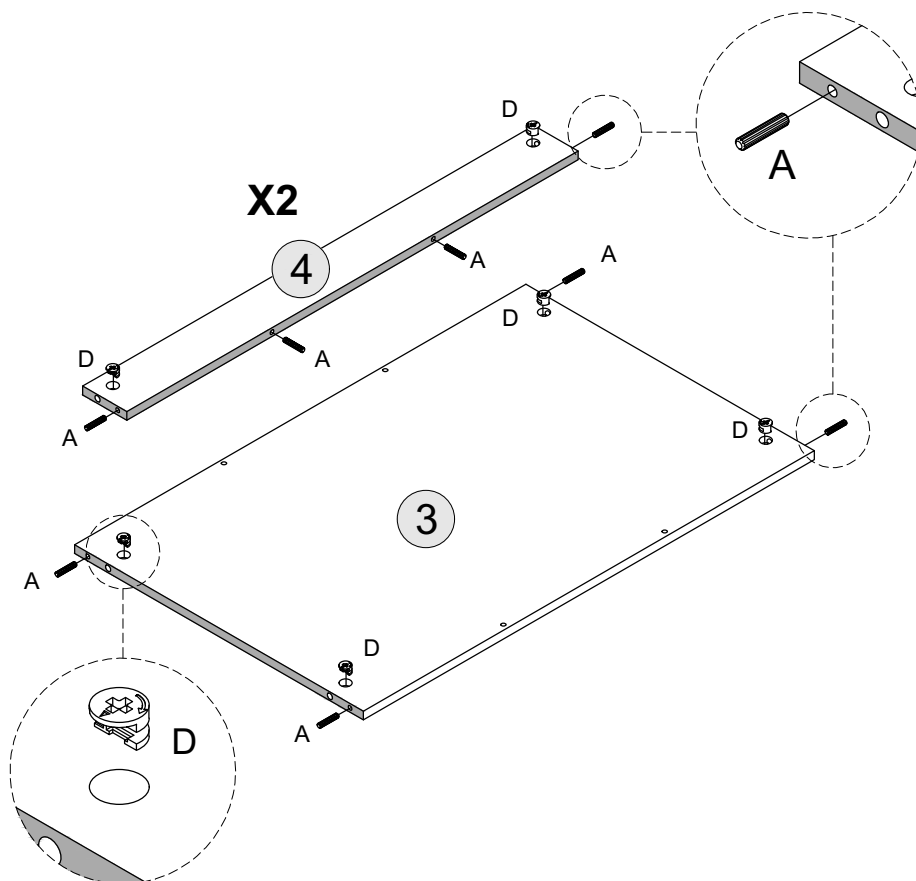
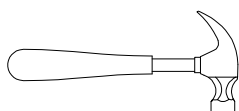

# STEP 3

**PARTS REQUIRED**

2 - SIDE PANEL - LEFT x1

**HARDWARE REQUIRED**

A  02

D  06

H  04

L  02

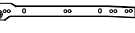
Q  01

**TOOLS REQUIRED**

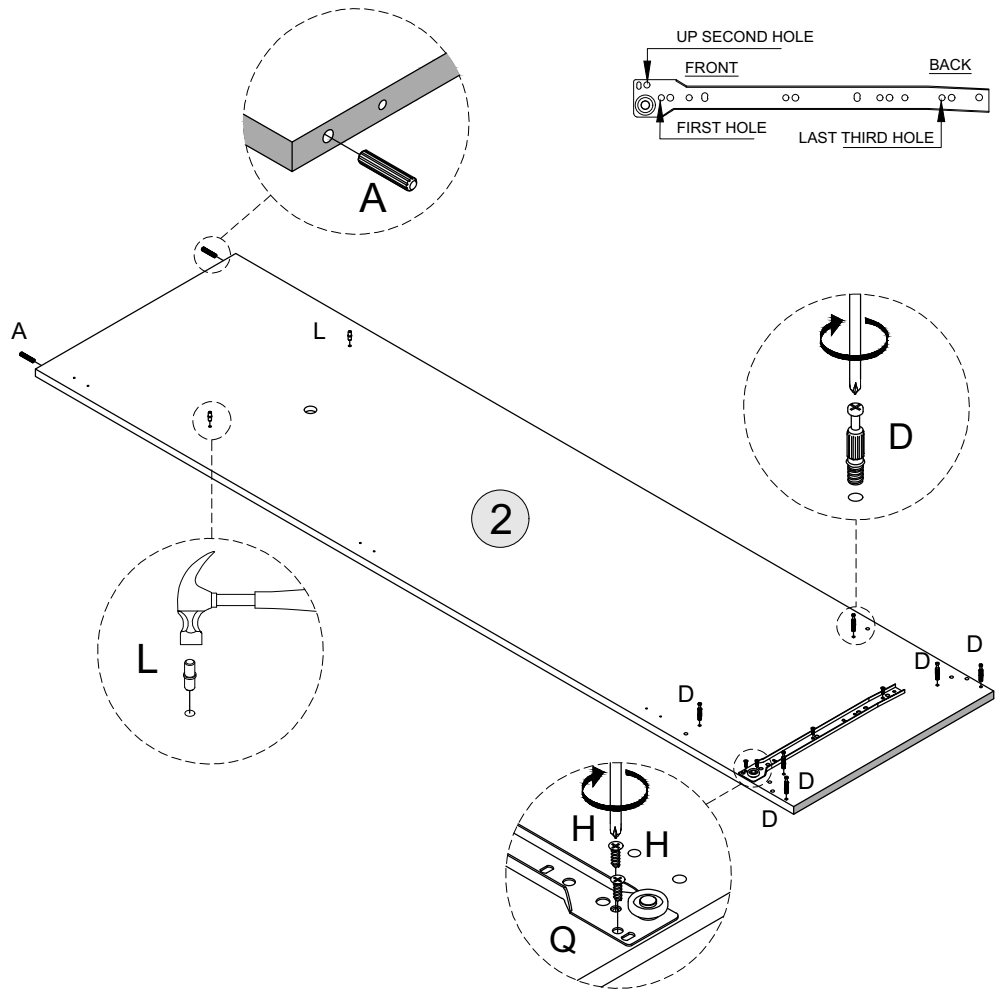
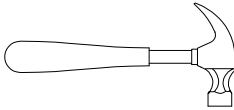
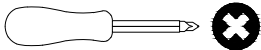

# STEP 4

**PARTS REQUIRED**

5 - SIDE PANEL - LEFT x1

**HARDWARE REQUIRED**

A  02

D  06

H  04

L  02

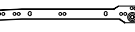
Q  01

**TOOLS REQUIRED**

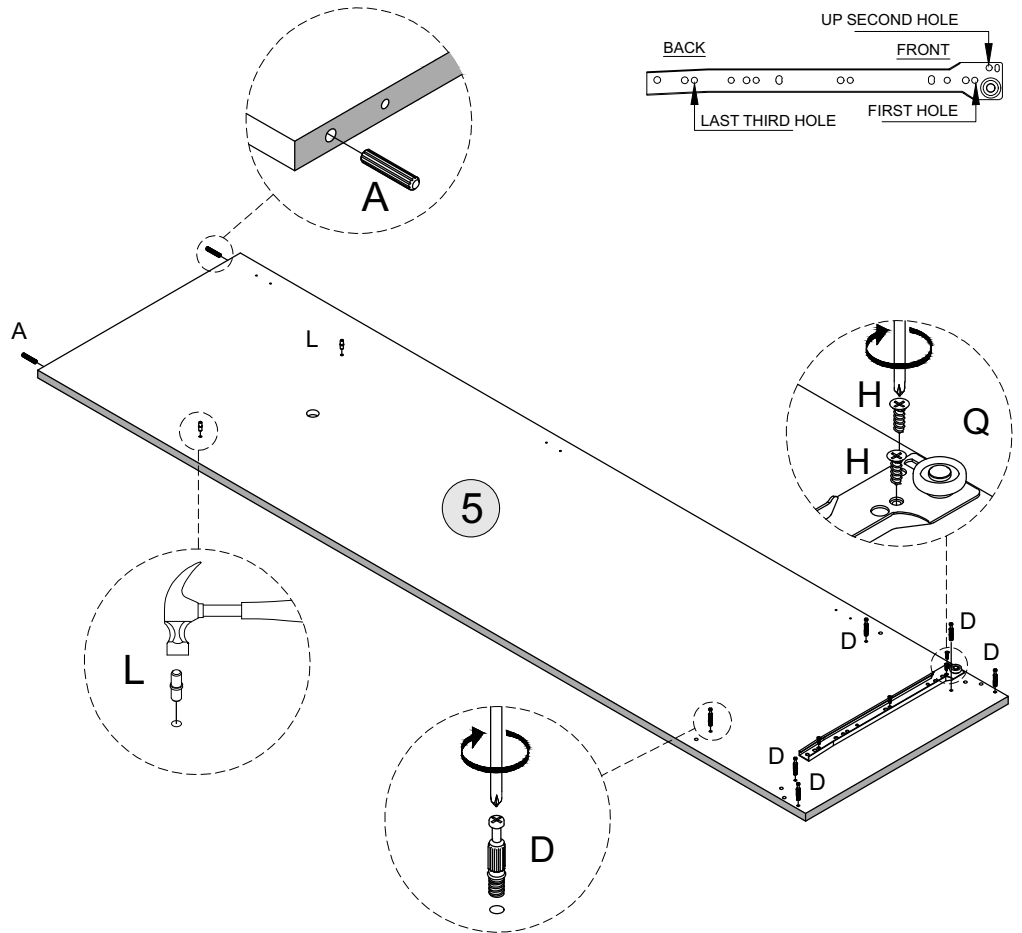
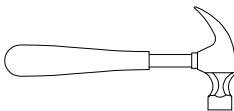
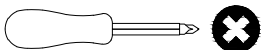

## STEP 5

### PARTS REQUIRED

1 - SHELF PANEL 1	x1
-------------------	----

2 - SIDE PANEL - LEFT	x1
-----------------------	----

### HARDWARE REQUIRED

### TOOLS REQUIRED

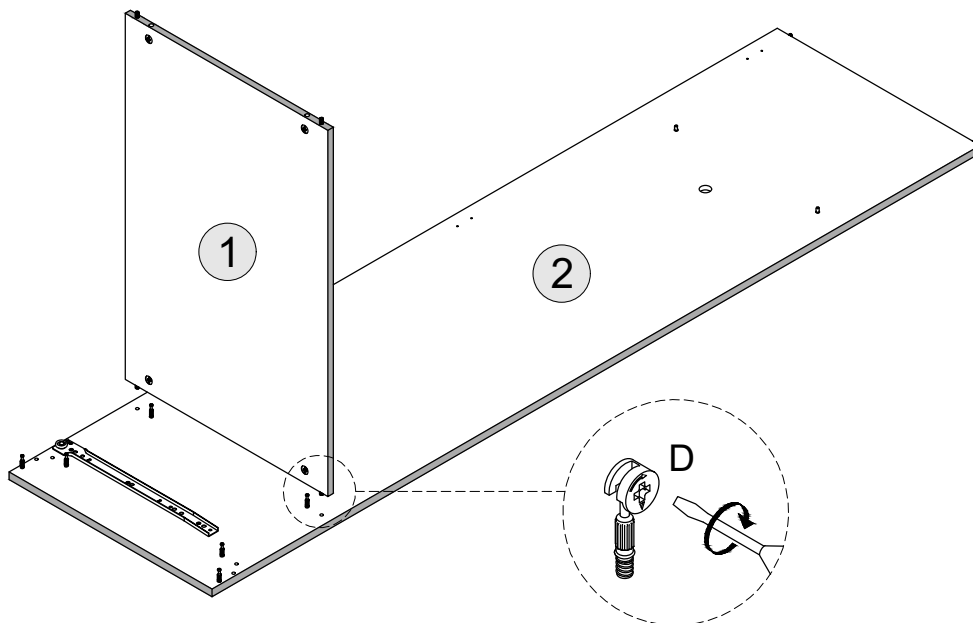
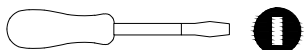

## STEP 6

### PARTS REQUIRED

3 - BOTTOM PANEL	x1
------------------	----

4 - BASE APRON	x2
----------------	----

### HARDWARE REQUIRED

### TOOLS REQUIRED

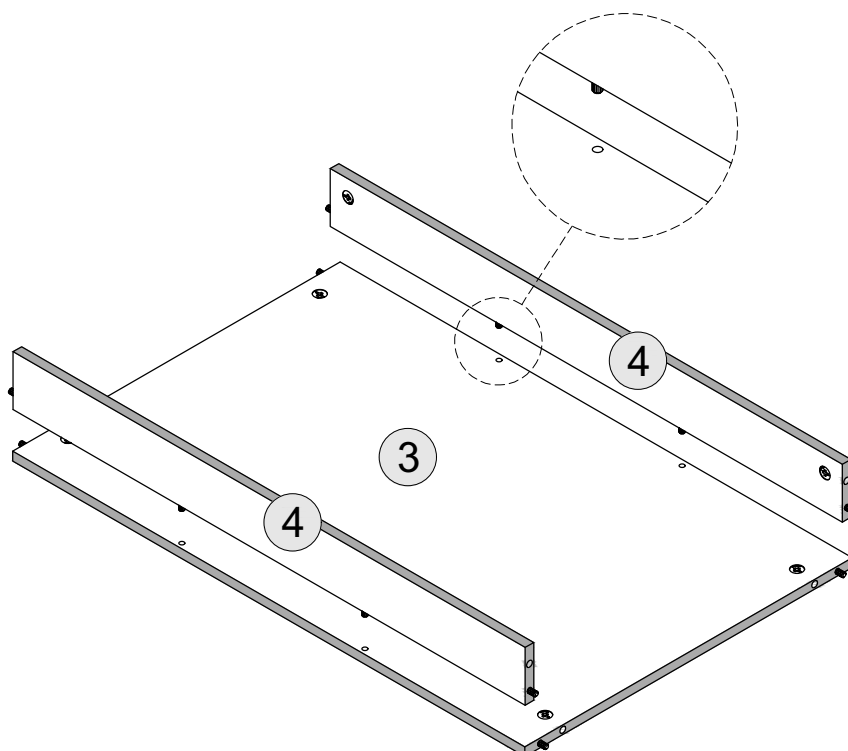

# STEP 7

PARTS REQUIRED

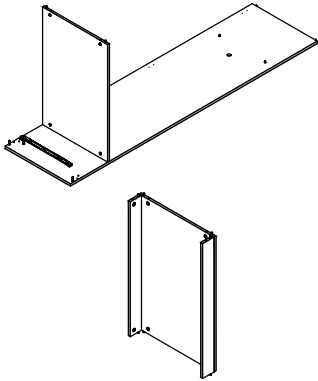

HARDWARE REQUIRED

TOOLS REQUIRED

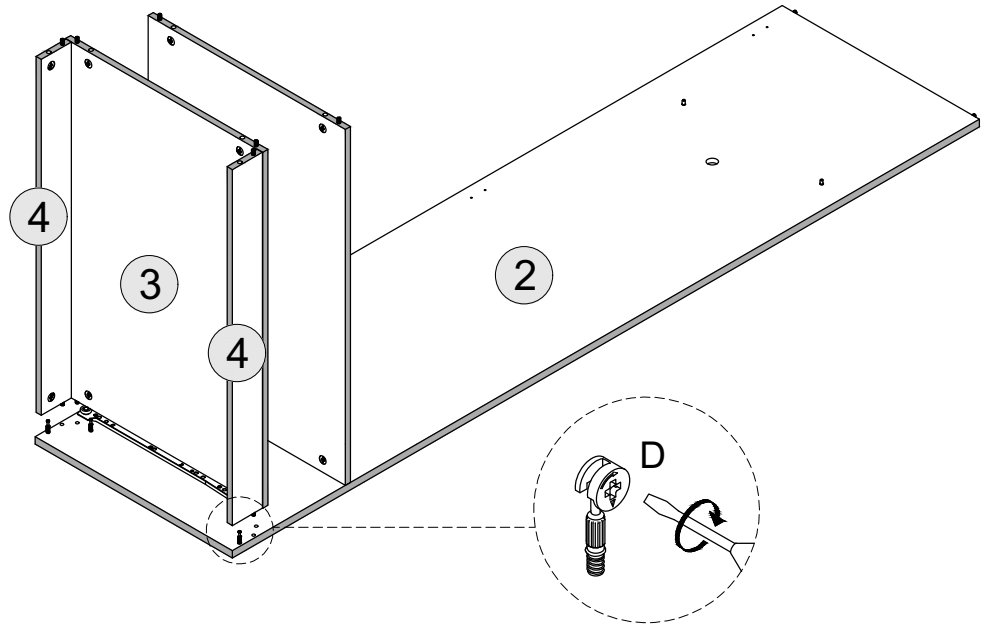
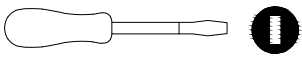

# STEP 8

PARTS REQUIRED

5 - SIDE PANEL - RIGHT x1

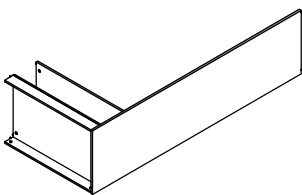

HARDWARE REQUIRED

TOOLS REQUIRED

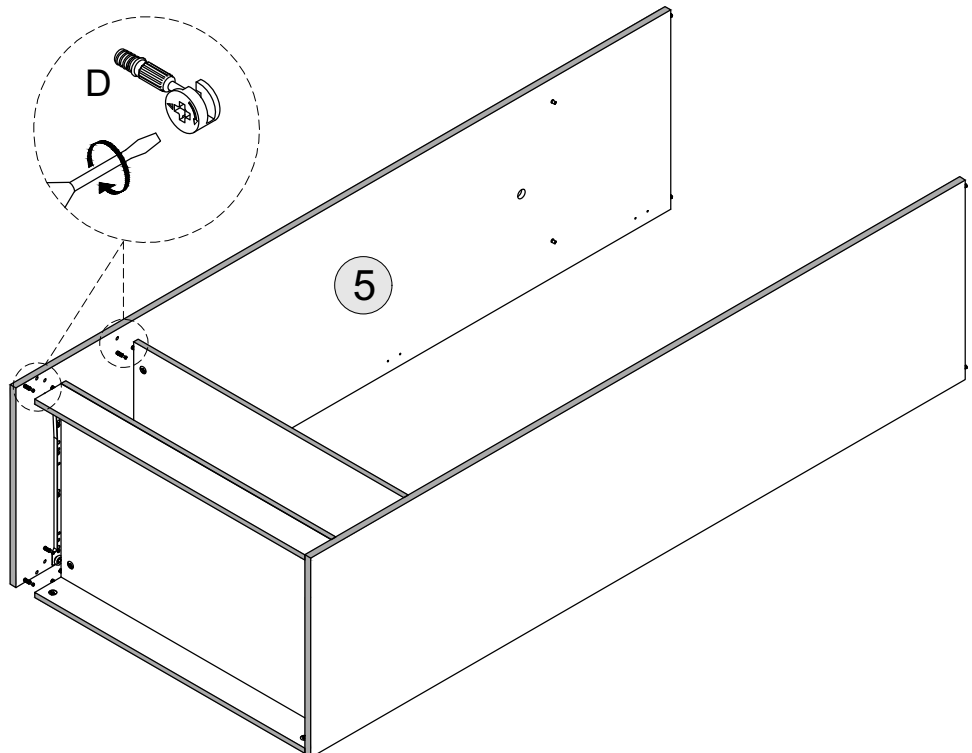
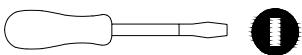

# STEP 9

**PARTS REQUIRED**

6 - TOP PANEL x1

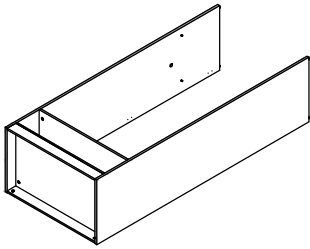

**HARDWARE REQUIRED**

B  04

O  01

**TOOLS REQUIRED**

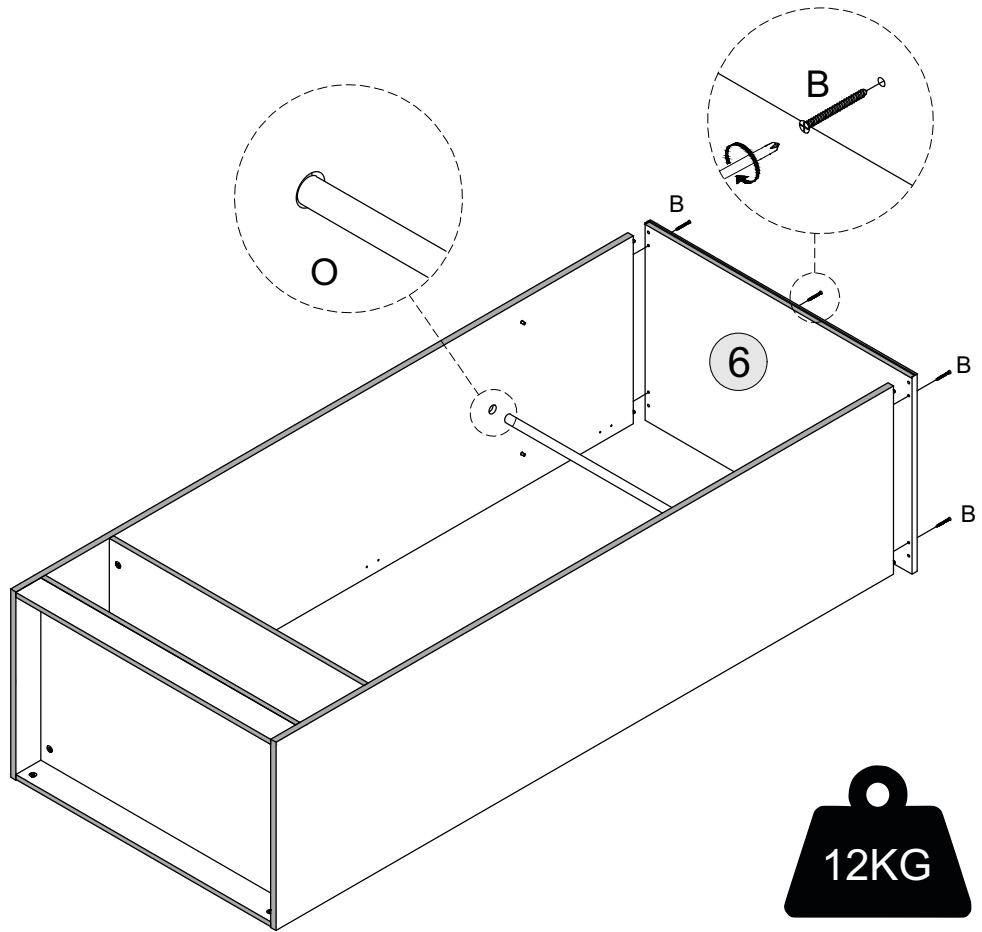
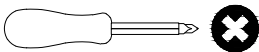

**12KG**  
HANGING RAIL  
MAX WEIGHT

# STEP 10

**PARTS REQUIRED**

7 - BACK PANEL 1 x2

8 - BACK PANEL 2 x2

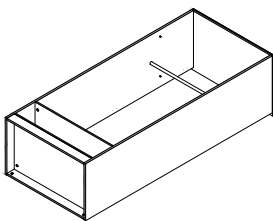

**HARDWARE REQUIRED**

G  36

J  03

K  04

**TOOLS REQUIRED**

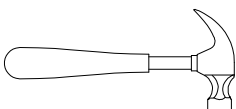

**IMPORTANT PLEASE FOLLOW !**

Ensure Part 7 is correctly aligned at the top before hammering Fitting G into the panel, as any misalignment will affect the final positioning of the doors once assembled.

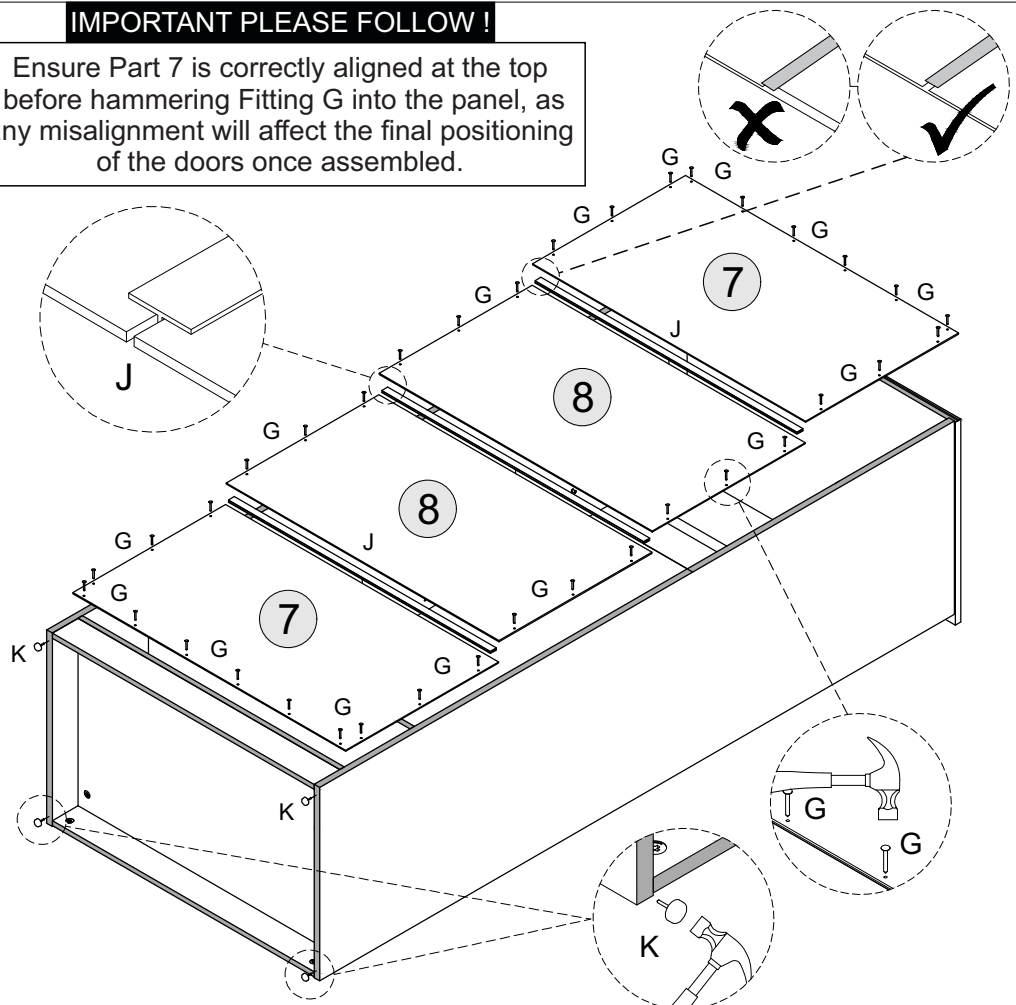



# STEP 11

**PARTS REQUIRED**

- 9 - DRAWER BACK x1
- 10 - DRAWER SIDE - LEFT x1
- 11 - DRAWER SIDE - RIGHT x1

**HARDWARE REQUIRED**

- A  08
- D  02
- S  02

**TOOLS REQUIRED**

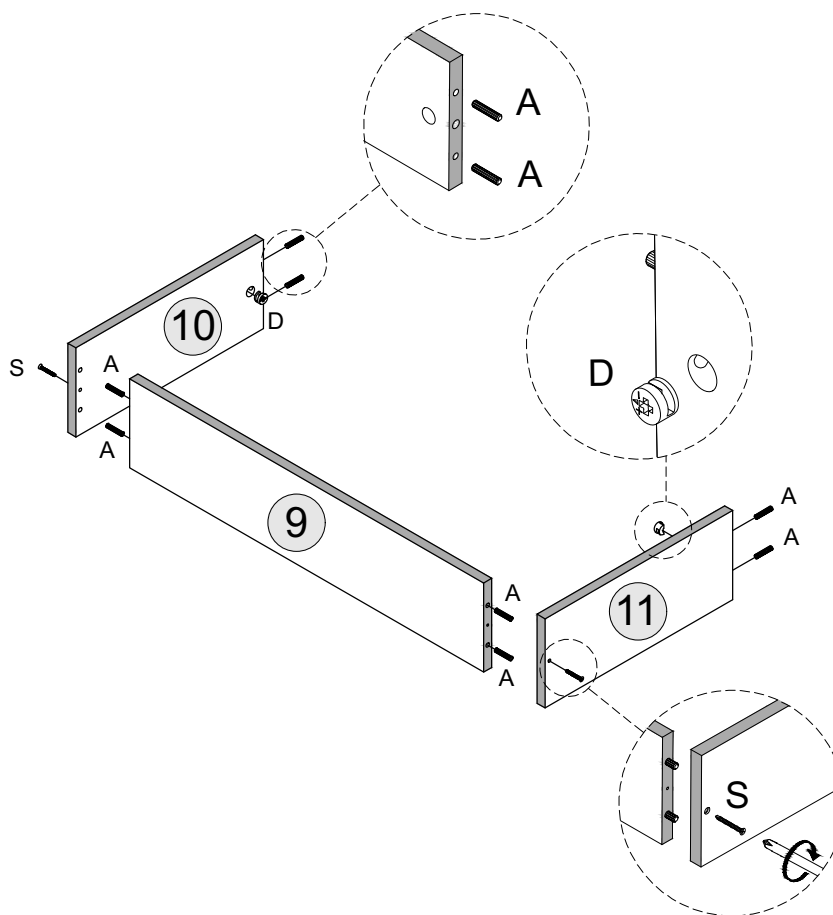
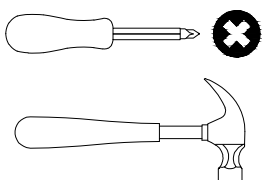

# STEP 12

**PARTS REQUIRED**

- 12 - DRAWER FRONT x1

**HARDWARE REQUIRED**

- D  02

**TOOLS REQUIRED**

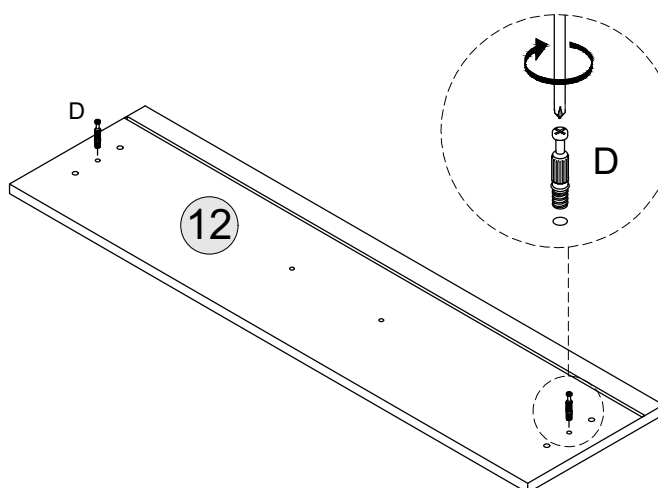
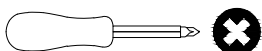

# STEP 13

**PARTS REQUIRED**

12 - DRAWER FRONT x1

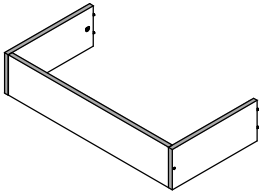

**HARDWARE REQUIRED**

E  01

F  02

**TOOLS REQUIRED**

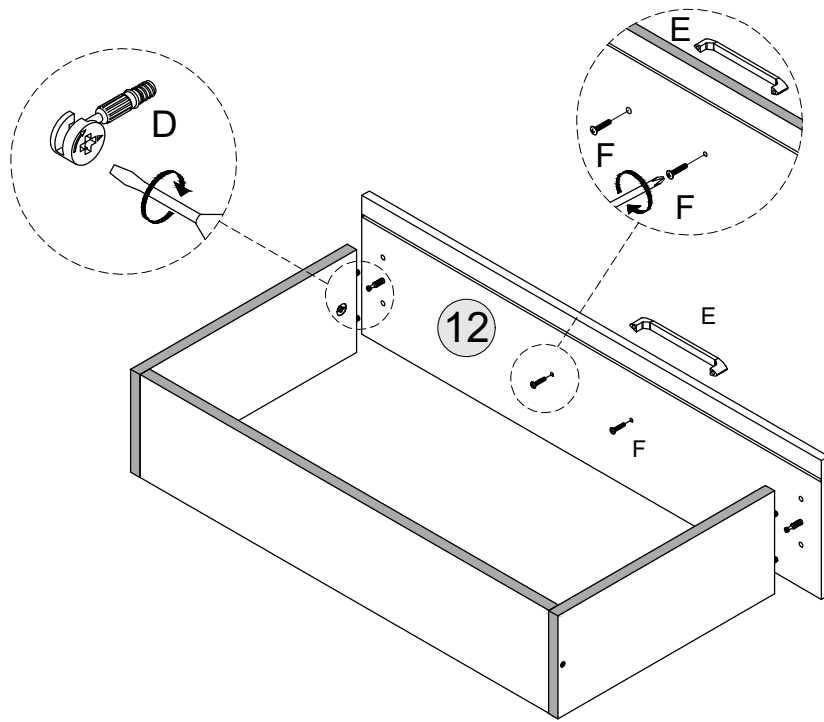
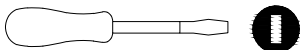
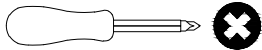

# STEP 14

**IMPORTANT PLEASE FOLLOW !**

Ensure Part 13 is correctly aligned and square with the drawer frame before hammering Fitting G into the back, as any misalignment will affect the final positioning of the drawers once assembled.

**PARTS REQUIRED**

13 - DRAWER BASE x1

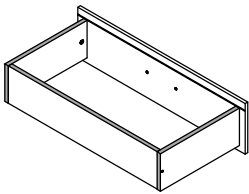

**HARDWARE REQUIRED**

G  08

**TOOLS REQUIRED**

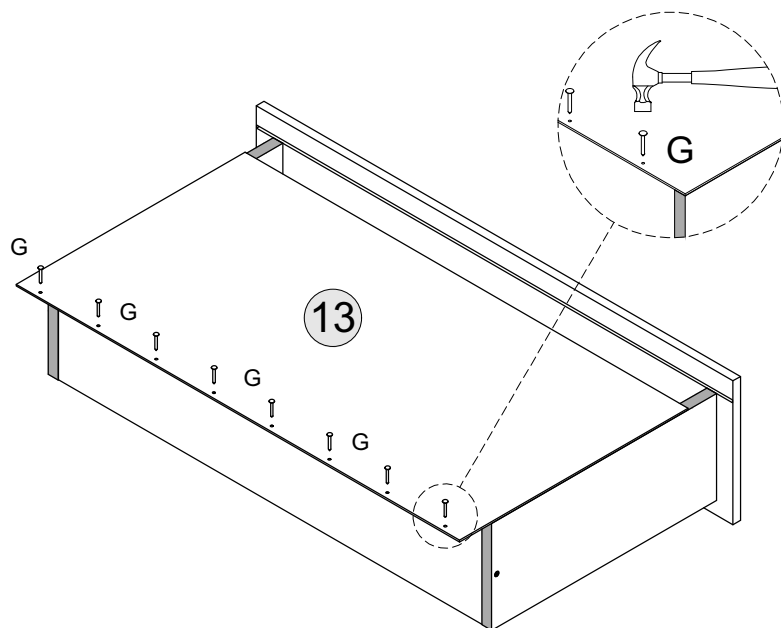
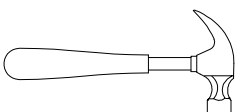

# STEP 15

PARTS REQUIRED

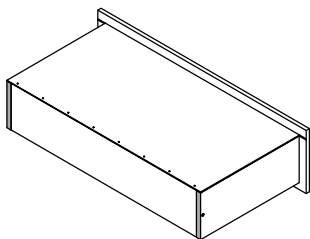

HARDWARE REQUIRED

C  06

P  02

R  02

TOOLS REQUIRED

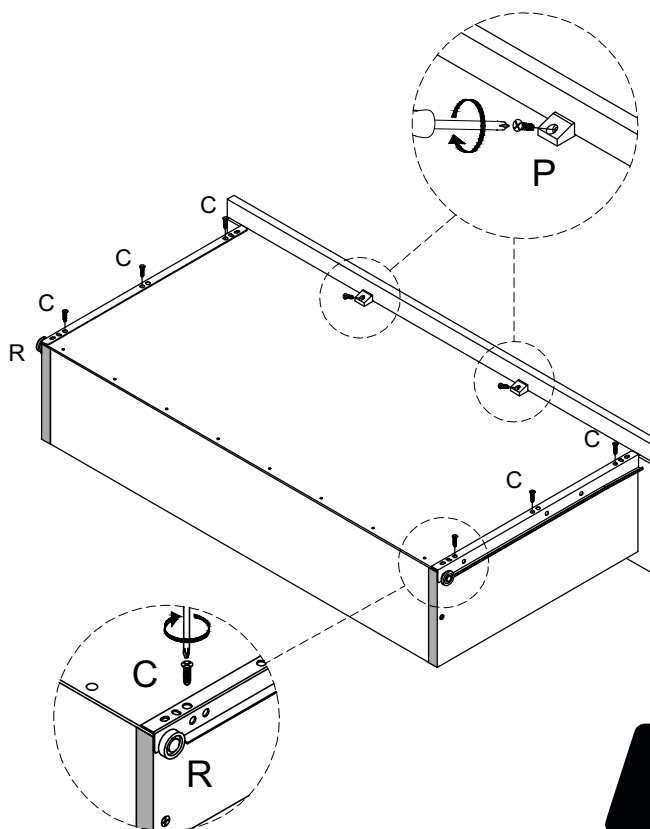
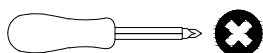

**MAX DRAWER WEIGHT**

# STEP 16

PARTS REQUIRED

14 - SHELF PANEL 2 x1

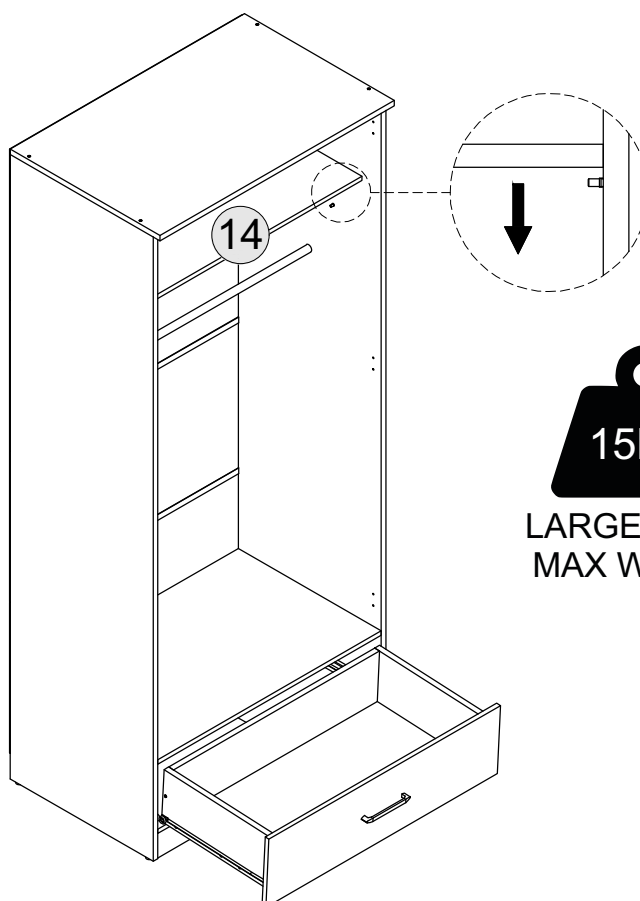
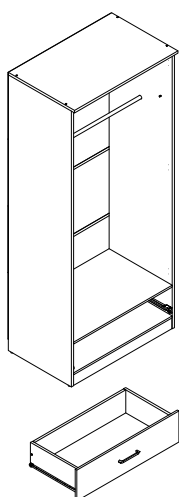

**LARGE SHELF MAX WEIGHT**

HARDWARE REQUIRED

TOOLS REQUIRED

# STEP 17

**PARTS REQUIRED**

15 - MIRRORED DOOR-RIGHT x1

16 - DOOR - LEFT x1

**HARDWARE REQUIRED**

H  12

M  06

**TOOLS REQUIRED**

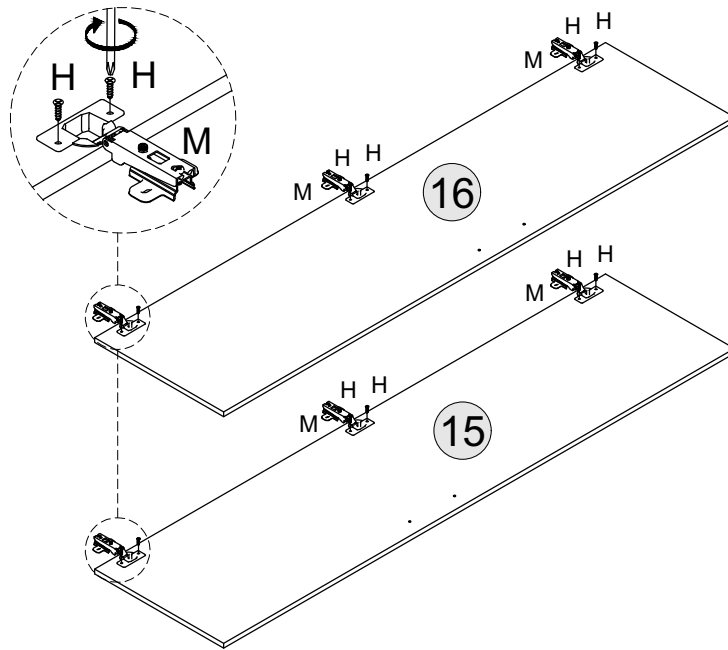
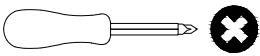

# STEP 18

**PARTS REQUIRED**

15 - MIRRORED DOOR-RIGHT x1

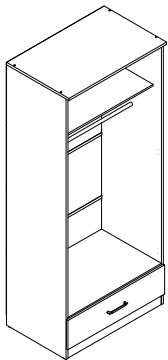

**HARDWARE REQUIRED**

E  01

F  02

N  06

**TOOLS REQUIRED**

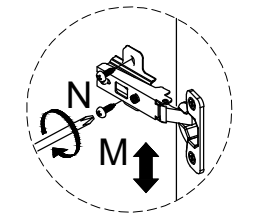
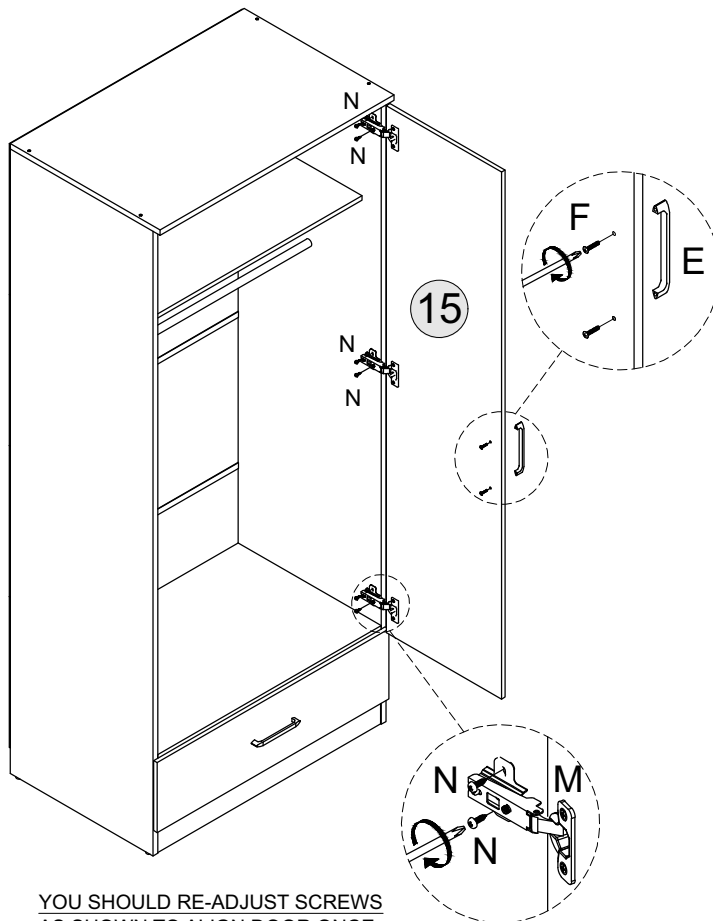
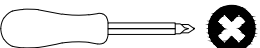

1. VERTICAL ADJUSTMENT VIA SLOT IN THE MOUNTING PLATE

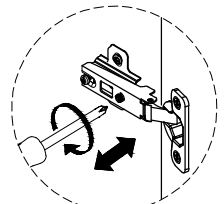

2. LATERAL ADJUSTMENT BY SCREW ADJUSTING

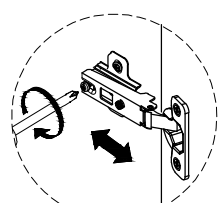

3. FRONT-TO-BACK BY THE SLACKING THE HINGE ARM MOUNTING SCREW

YOU SHOULD RE-ADJUST SCREWS AS SHOWN TO ALIGN DOOR ONCE HINGES HAVE BEEN ATTACHED.

# STEP 19

**PARTS REQUIRED**

16 - DOOR - LEFT x1

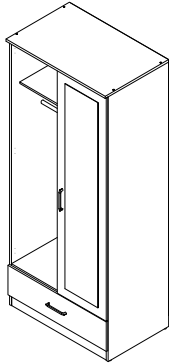

**HARDWARE REQUIRED**

E		01
F		02
N		06

**TOOLS REQUIRED**

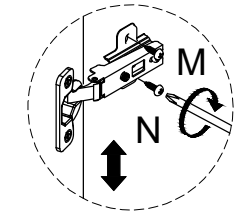
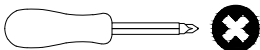

1. VERTICAL ADJUSTMENT VIA SLOT IN THE MOUNTING PLATE

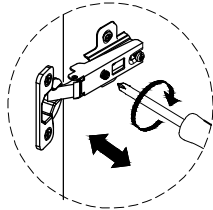

2. LATERAL ADJUSTMENT BY SCREW ADJUSTING

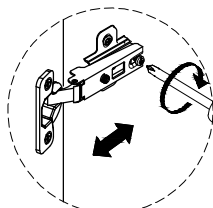

3. FRONT-TO-BACK BY THE SLACKING THE HINGE ARM MOUNTING SCREW

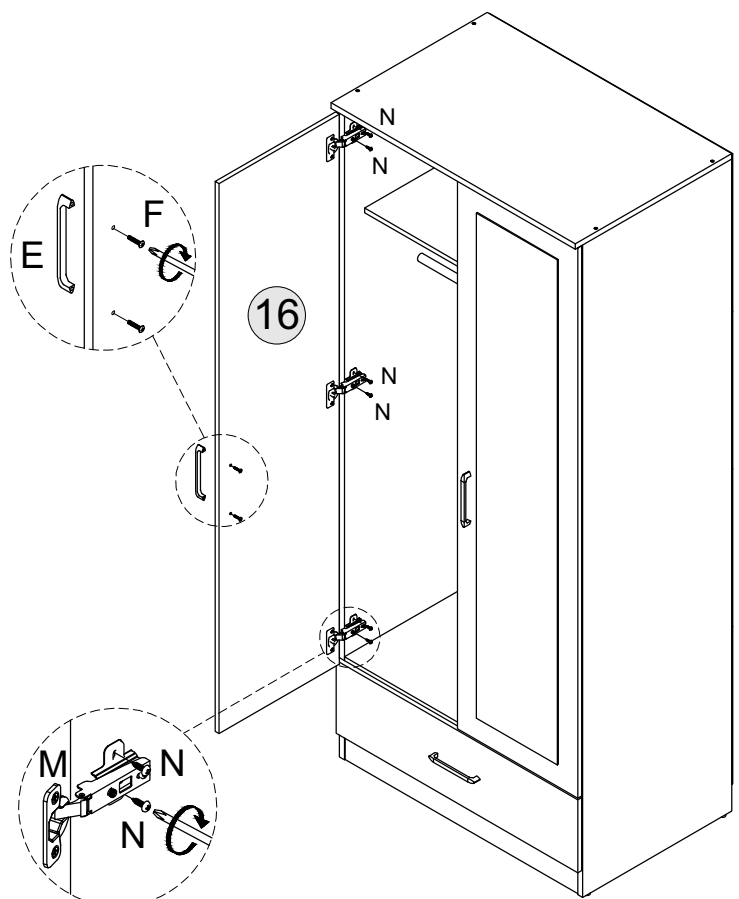

**YOU SHOULD RE-ADJUST SCREWS AS SHOWN TO ALIGN DOOR ONCE HINGES HAVE BEEN ATTACHED.**

# STEP 20

**PARTS REQUIRED**

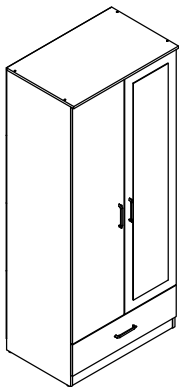

**HARDWARE REQUIRED**

T		02
U		02

**TOOLS REQUIRED**

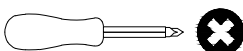

## WARNING

Serious or fatal injuries can occur from furniture tipping over. To prevent the furniture from tipping over we recommend that it is permanently fixed to the wall.

Wall fixings are not supplied with this product as different wall materials require different types of fixing devices. Please make sure you use fixings suitable for the walls in your home.

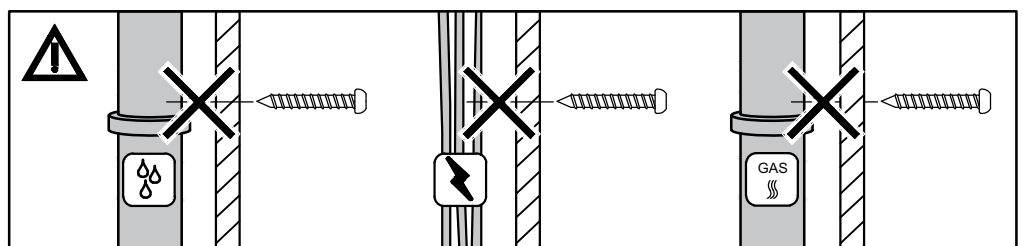
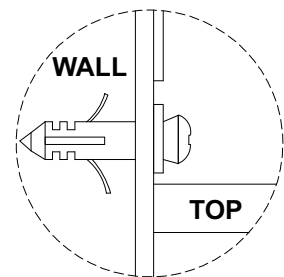
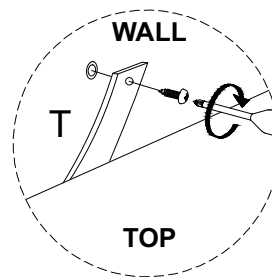
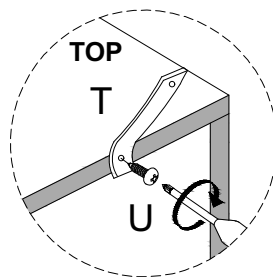

INFORMATIONS IMPORTANTES (FRENCH)	INFORMACIÓN IMPORTANTE (SPANISH)
<p style="text-align: center;"><b>IMPORTANTE POUR USAGE DOMESTIQUE UNIQUEMENT VEUILLEZ LIRE AVANT DE CONTINUER</b></p> <p>Le produit que vous avez acheté vous offrira de nombreuses années de service si vous suivez les directives pour son assemblage sûr et son entretien et nettoyage périodiques. Montez sur une surface douce et propre. N'utilisez aucun autre outil que ceux indiqués. Les clés ou clés Allen nécessaires sont fournies avec le kit de fixation. En fonction de la fréquence d'utilisation de ce produit, il peut être nécessaire de resserrer les fixations de temps en temps. Cela est tout à fait normal pour tout meuble en kit. Ce produit comprend du verre trempé d'une épaisseur nominale de 8 mm. Si le verre est ébréché ou cassé, remplacez-le par le type décrit ou consultez les détaillants en indiquant les détails du modèle. <b>AVERTISSEMENT</b> La charge maximale sur le dessus ne doit pas dépasser la limite de poids indiquée sur la première page. Ne vous asseyez pas ou ne vous tenez pas debout sur les surfaces en verre. N'utilisez pas le verre comme surface de coupe. Ne frappez pas le verre avec des objets durs ou pointus. Ne placez pas d'objets très chauds ou très froids sur la surface en verre, à moins que des sets de table suffisamment épais ne soient utilisés pour empêcher ces objets d'entrer en contact avec le verre. Pour nettoyer les panneaux en verre, utilisez un chiffon humide ou un cuir avec du liquide vaisselle ou du savon doux si nécessaire. N'utilisez pas de lessive en poudre ou toute autre substance contenant des abrasifs car ceux-ci rayent considérablement le verre. L'utilisation d'outils électriques pour assembler ce produit invalidera toute réclamation et peut endommager ce produit, le rendant dangereux. Conservez ces instructions dans un endroit sûr pour référence ultérieure.</p>	<p style="text-align: center;"><b>IMPORTANTE SOLO PARA USO DOMÉSTICO LEER ANTES DE CONTINUAR</b></p> <p>El producto que ha adquirido le brindará muchos años de servicio si sigue las pautas para su montaje seguro y su mantenimiento y limpieza periódicos. Ensamble sobre una superficie suave y limpia. No utilice herramientas distintas a las que se muestran. Las llaves inglesas o llaves Allen necesarias se incluyen con el kit de accesorios. Dependiendo de la cantidad de uso que reciba este producto, puede ser necesario apretar las fijaciones de vez en cuando. Esto es completamente normal en cualquier mueble de paquete plano. Este producto incluye vidrio templado con un espesor nominal de 8 mm. Si el vidrio está astillado o roto, reemplácelo con el tipo descrito o, alternativamente, consulte con los minoristas indicando los detalles del modelo. <b>ADVERTENCIA</b> La carga máxima en la parte superior no excede el límite de peso que se muestra en la página principal. No se siente ni se pare sobre superficies de vidrio. No use el vidrio como superficie para cortar. No golpee el vidrio con elementos duros o puntiagudos. No coloque elementos muy calientes o muy fríos sobre la superficie de vidrio a menos que se utilicen manteles individuales lo suficientemente gruesos para evitar que dichos elementos entren en contacto con el vidrio. Para limpiar los paneles de vidrio, utilice un paño húmedo o un paño de cuero con detergente líquido o jabón suave, si es necesario. No utilice detergente en polvo ni ninguna otra sustancia que contenga abrasivos, ya que rayan considerablemente el vidrio. El uso de herramientas eléctricas para ensamblar este producto invalidará cualquier reclamo y puede dañar este producto, haciéndolo inseguro. Guarde estas instrucciones en un lugar seguro para futuras consultas.</p>
WICHTIGE INFORMATIONEN (GERMAN)	INFORMAZIONI IMPORTANTI (ITALIAN)
<p style="text-align: center;"><b>WICHTIGUR FÜR DEN HAUSHALTSGEBRAUCH BITTE LESEN SIE, BEVOR SIE FORTFAHREN</b></p> <p>Das von Ihnen erworbene Produkt wird Ihnen viele Jahre lang gute Dienste leisten, wenn Sie die Richtlinien für eine sichere Montage und regelmäßige Wartung und Reinigung befolgen. Auf einer weichen, sauberen Oberfläche montieren. Verwenden Sie keine anderen Werkzeuge als die abgebildeten. Alle benötigten Schraubenschlüssel oder Inbusschlüssel sind im Montagesatz enthalten. Je nach Nutzungsintensität dieses Produkts kann es erforderlich sein, die Befestigungen von Zeit zu Zeit festzuziehen. Dies ist bei Möbeln aus dem Bausatz völlig normal. Dieses Produkt enthält gehärtetes Glas mit einer Nennstärke von 8 mm. Wenn das Glas angeschlagen oder zerbrochen ist, ersetzen Sie es bitte durch das beschriebene Glas oder wenden Sie sich alternativ an den Händler und geben Sie die Modelldetails an. <b>WARNUNG</b> Die maximale Belastung oben darf die auf der Titelseite angegebene Gewichtsgrenze nicht überschreiten. Setzen oder stellen Sie sich nicht auf Glasoberflächen. Verwenden Sie Glas nicht als Schneideunterlage. Schlagen Sie nicht mit harten oder spitzen Gegenständen auf Glas. Stellen Sie keine sehr heißen oder sehr kalten Gegenstände auf die Glasoberfläche, es sei denn, Sie verwenden ausreichend dicke Tischmatten, um zu verhindern, dass diese Gegenstände mit dem Glas in Berührung kommen. Verwenden Sie zum Reinigen von Glasscheiben ein feuchtes Tuch oder Leder mit Spülmittel oder Schmierseife, falls erforderlich. Verwenden Sie kein Waschpulver oder andere scheuernde Substanzen, da diese das Glas stark zerkratzen. Die Verwendung von Elektrowerkzeugen zur Montage dieses Produkts macht jegliche Ansprüche ungültig und kann das Produkt beschädigen, wodurch es unsicher wird. Bewahren Sie diese Anleitung zum späteren Nachschlagen an einem sicheren Ort auf.</p>	<p style="text-align: center;"><b>IMPORTANTE, SOLO PER USO DOMESTICO SI PREGA DI LEGGERE PRIMA DI CONTINUARE OLTRE</b></p> <p>Il prodotto che hai acquistato ti garantirà molti anni di servizio se seguirai le linee guida per il suo montaggio sicuro e la manutenzione e pulizia periodiche. Montare su una superficie morbida e pulita. Non utilizzare utensili diversi da quelli mostrati. Tutte le chiavi inglesi o le chiavi a brugola necessarie sono incluse nel kit di accessori. A seconda della quantità di utilizzo di questo prodotto, potrebbe essere necessario stringere i fissaggi di tanto in tanto. Ciò è del tutto normale per qualsiasi mobile in kit. Questo prodotto include vetro temperato con uno spessore nominale di 8 mm. Se il vetro è scheggiato o rotto, sostituirlo con il tipo descritto o in alternativa consultare i rivenditori indicando i dettagli del modello. <b>AVVERTENZA</b> Il carico massimo sulla parte superiore non deve superare il limite di peso indicato sulla prima pagina. Non sedersi o stare in piedi sulle superfici in vetro. Non utilizzare il vetro come superficie di taglio. Non colpire il vetro con oggetti duri o appuntiti. Non posizionare oggetti molto caldi o molto freddi sulla superficie in vetro a meno che non vengano utilizzati tovagliette adeguatamente spesse per evitare che tali oggetti entrino in contatto con il vetro. Per la pulizia dei pannelli in vetro, utilizzare un panno umido o pelle con detersivo per piatti o sapone delicato, se necessario. Non utilizzare detersivo in polvere o altre sostanze contenenti abrasivi, poiché graffiano notevolmente il vetro. L'uso di utensili elettrici per assemblare questo prodotto invaliderà qualsiasi reclamo e potrebbe danneggiare il prodotto rendendolo non sicuro. Conservare queste istruzioni in un luogo sicuro per riferimento futuro.</p>