

118"x118"x79" Outdoor Pet Run Owner's Manual

Tip: Shipped out as 1 box.
Please feel free to contact us if there is damage or parts missing.
24 Hours After-Sales Service.

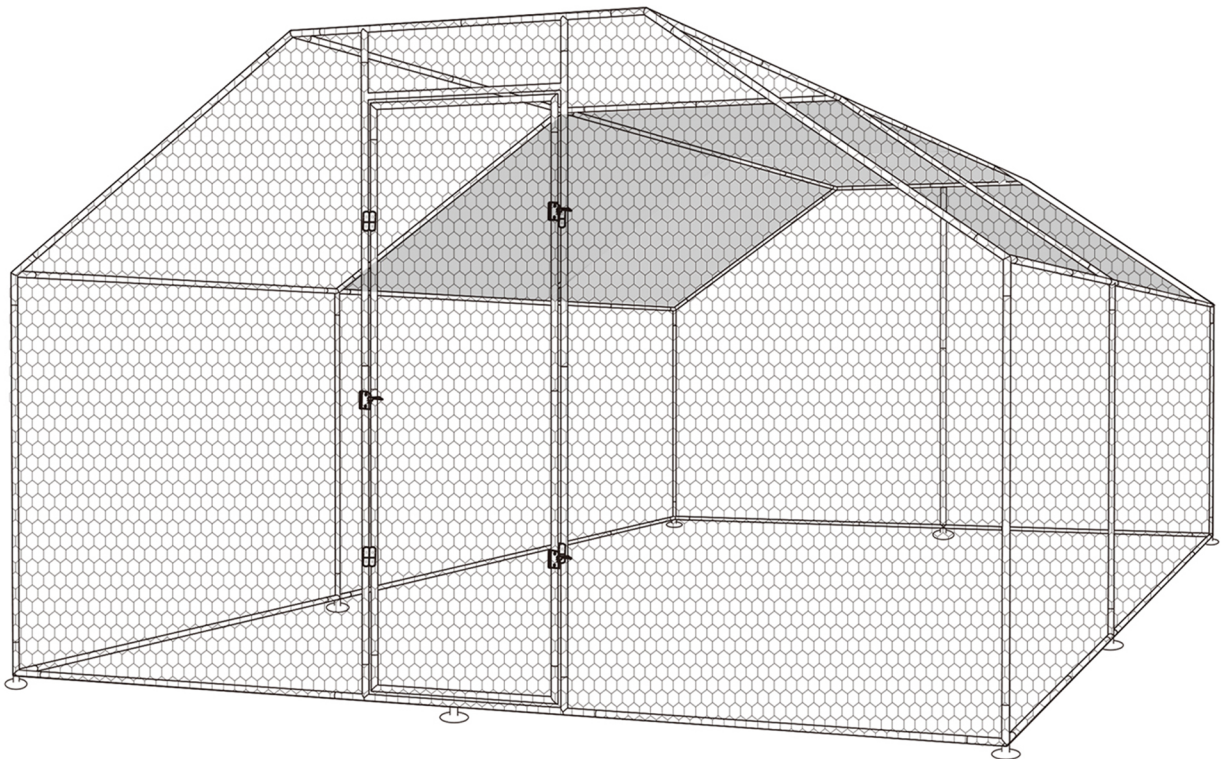

Watch the weather: Better select a calm day to install this item.
Teamwork: More partners to complete this item may be more efficient.
Tools: Basic tools are needed in assembly.

Before You Begin

Owner's Manual

Before beginning construction, check local building codes regarding footings, location and other requirements. Study and understand this owner's manual. Important information and helpful tips will make your construction easier and more enjoyable.

Assembly Instructions: Instructions are supplied in this manual and contain all appropriate information for your building model. Review all instructions before you begin, and during assembly, follow the step sequence carefully for correct results.

Parts and Parts List: Check to be sure that you have all the necessary parts for building .

Separate contents of the carton by the part number while reviewing parts list.

The first few steps show how to join related parts to make larger sub assemblies which will be used later.

Familiarize yourself with the hardware and fasteners for easier use during construction.

These are packaged within the carton. Note that extra fasteners have been supplied for your convenience.

Plan Ahead





Watch the Weather: Be sure the day you select to install your building is dry and calm.





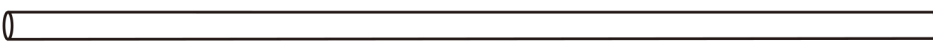
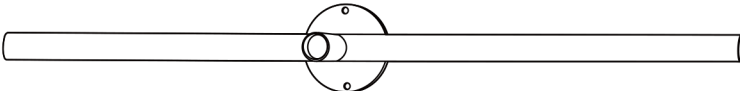
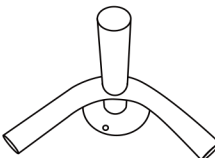
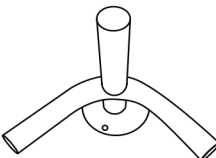
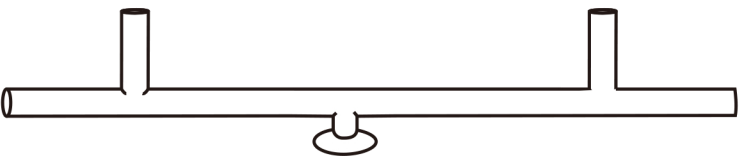
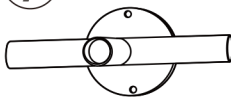

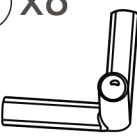
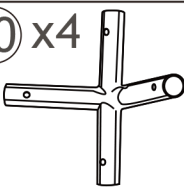
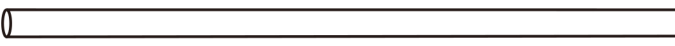

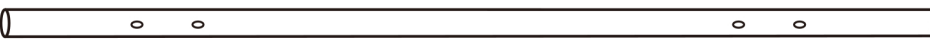
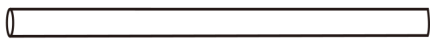
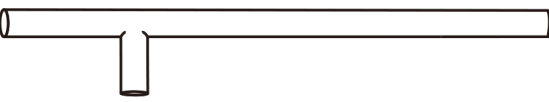
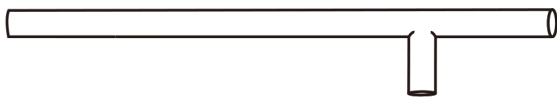
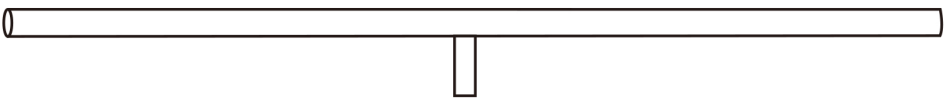

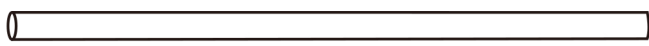
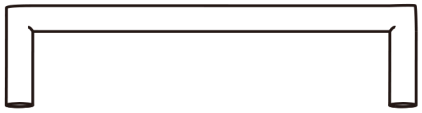
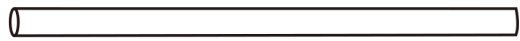

Do not attempt to assemble your building on a windy day.

Teamwork: Whenever possible, two or more people should work together to assemble your building. One person can position parts or panels while the other is able to handle the fasteners and the tools.

Tools and Materials: These are some basic tools and materials you will need for the construction of your building. Decide which method of anchoring and the type of foundation you wish to use in order to form a complete list of the materials you will need.

Parts list

① x12:133.5cm 		
② x4:106.5cm 		
③ x1:84cm 		
④ x2 	⑤ x2 	⑥ x1:84.5cm 
⑦ x2 	⑧ x6:94.5cm 	
⑨ x8 	⑩ x4 	⑪ x6:103.5cm 
⑫ x1:94.5cm 		
⑬ x1:94.5cm 		
⑭ x1:60.5cm 		
⑮ x1:64cm 	⑯ x1:64cm 	
⑰ x1:122cm 		

18 x1:122cm 			
19 x1:94.5cm 			
20 x2:89cm 	23 x1:90cm 		
21 x1:133.5cm 	24 x1:90cm 		
22 x1:133.5cm 	25 x1:90cm 		
Gx2 	Hx4 	Ix2 	
Jx8 	Mx2 	16x 	220x 

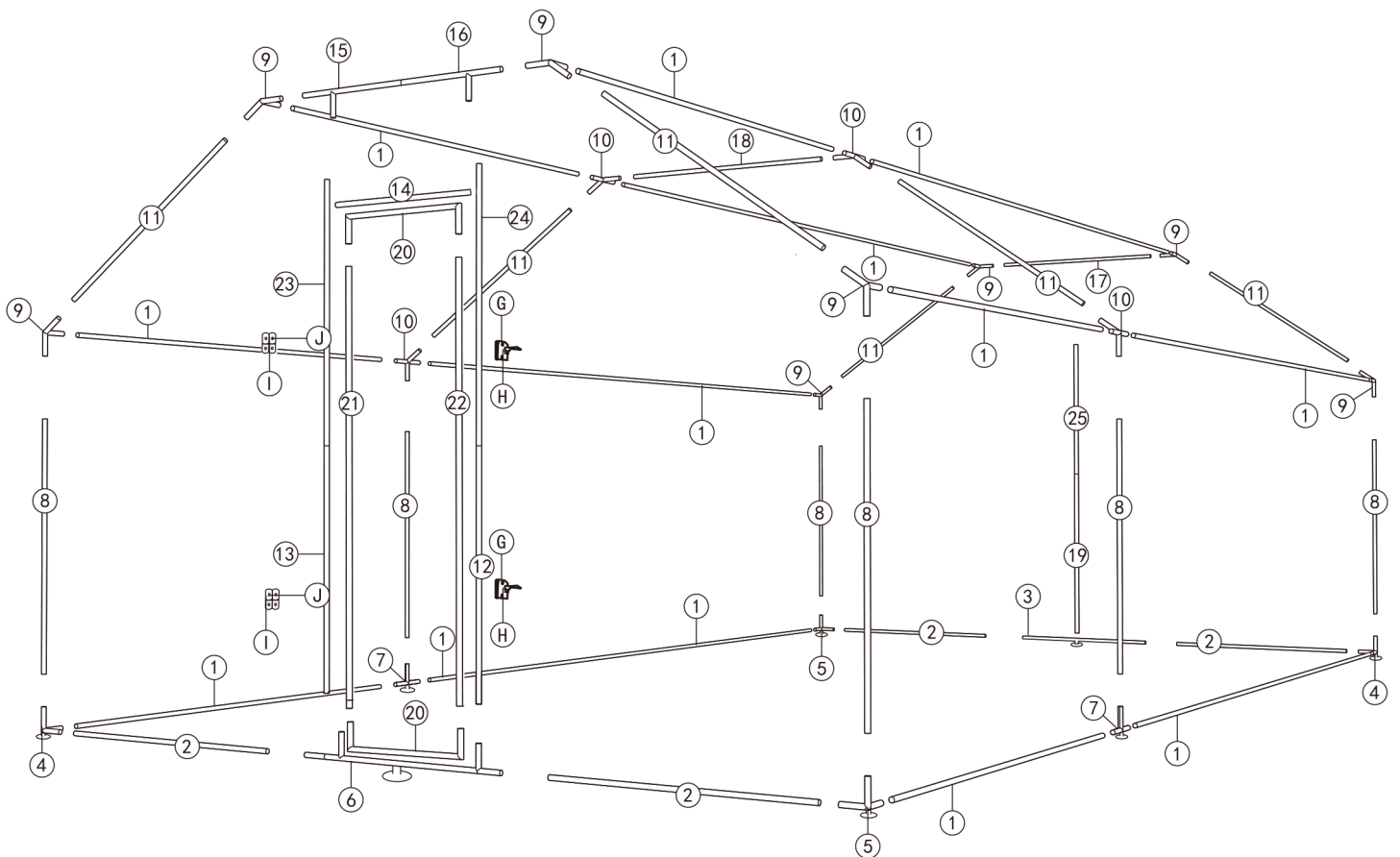

Assembly

1

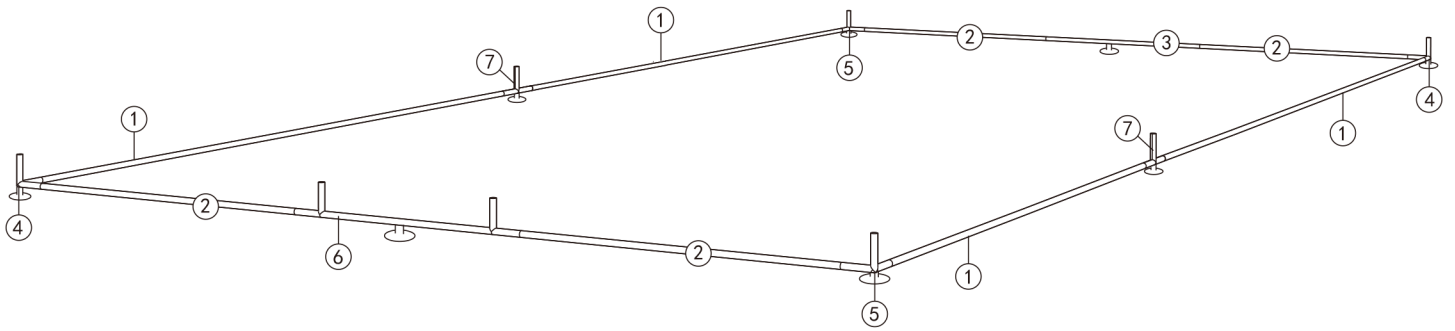

①x4	
②x4	
③x1	
④x2	
⑤x2	
⑥x1	
⑦x2	

2

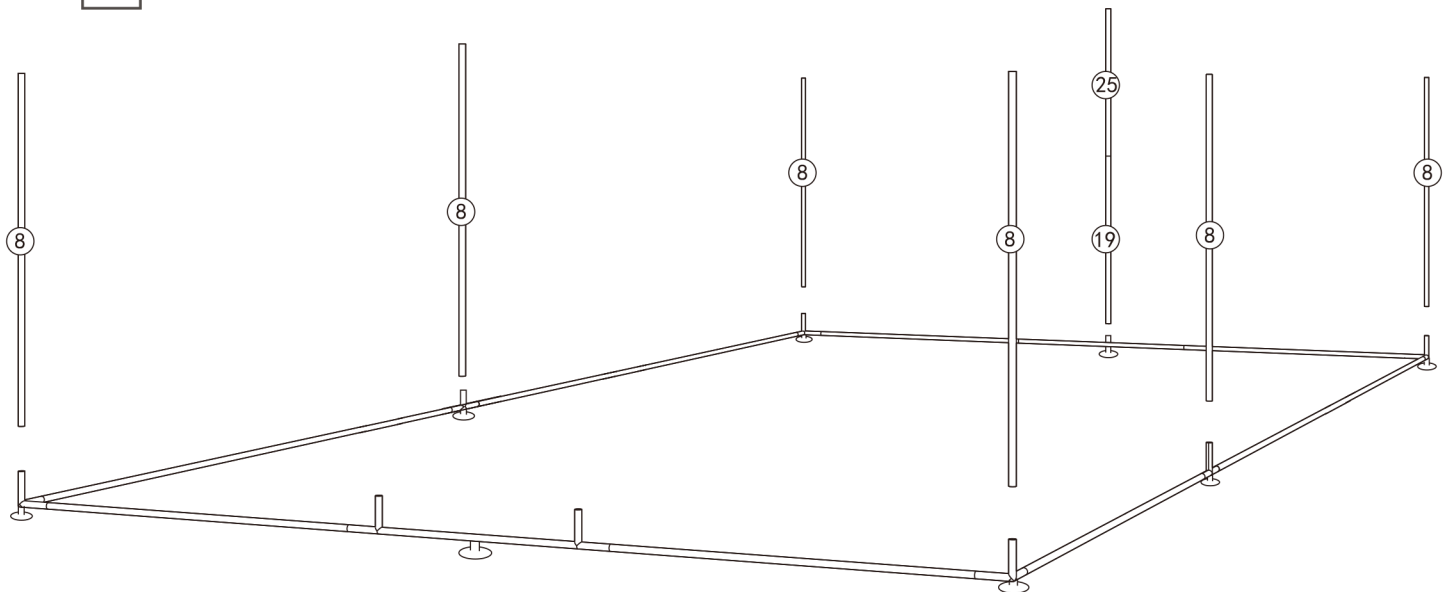

⑧x6	
⑱x1	
⑳x1	

3

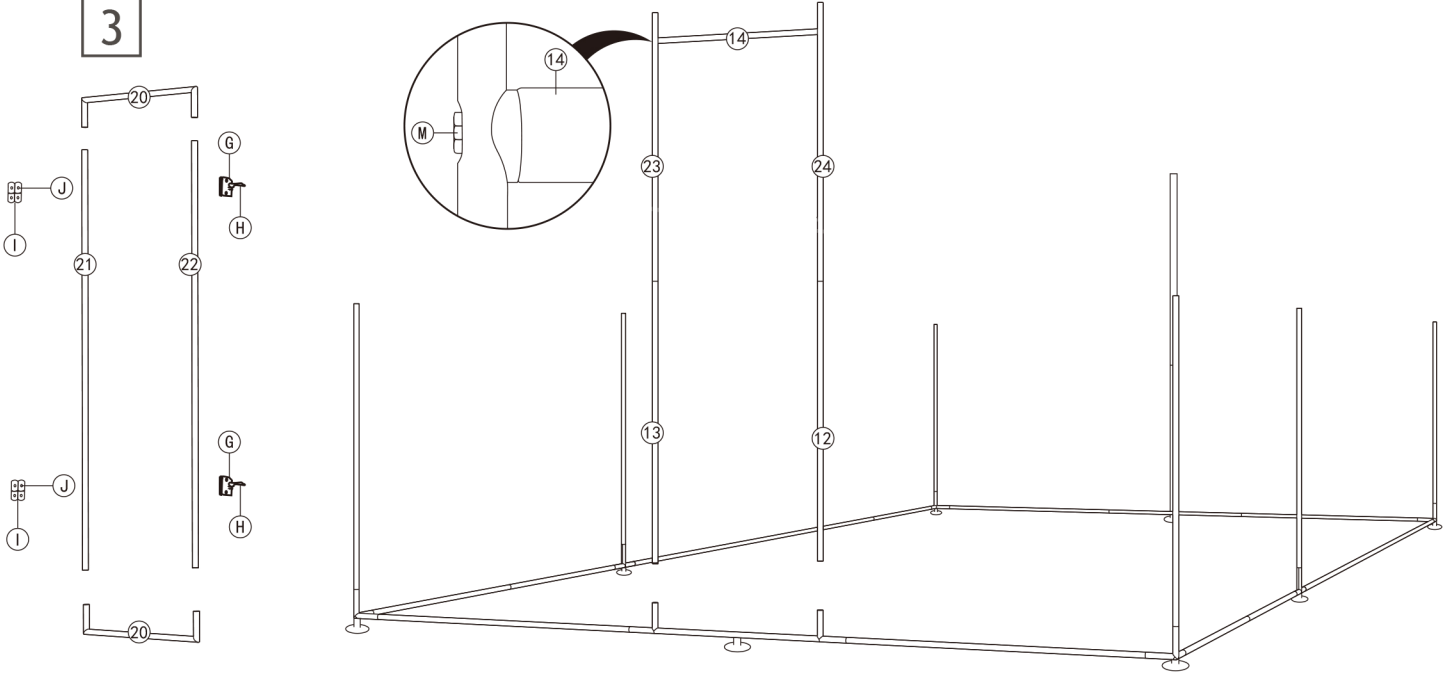

12 x1		20 x1					
13 x1		23 x1					
14 x1		24 x1					
21 x1		Gx2	Hx4	Ix2	Jx8	Mx2	
22 x1							

4

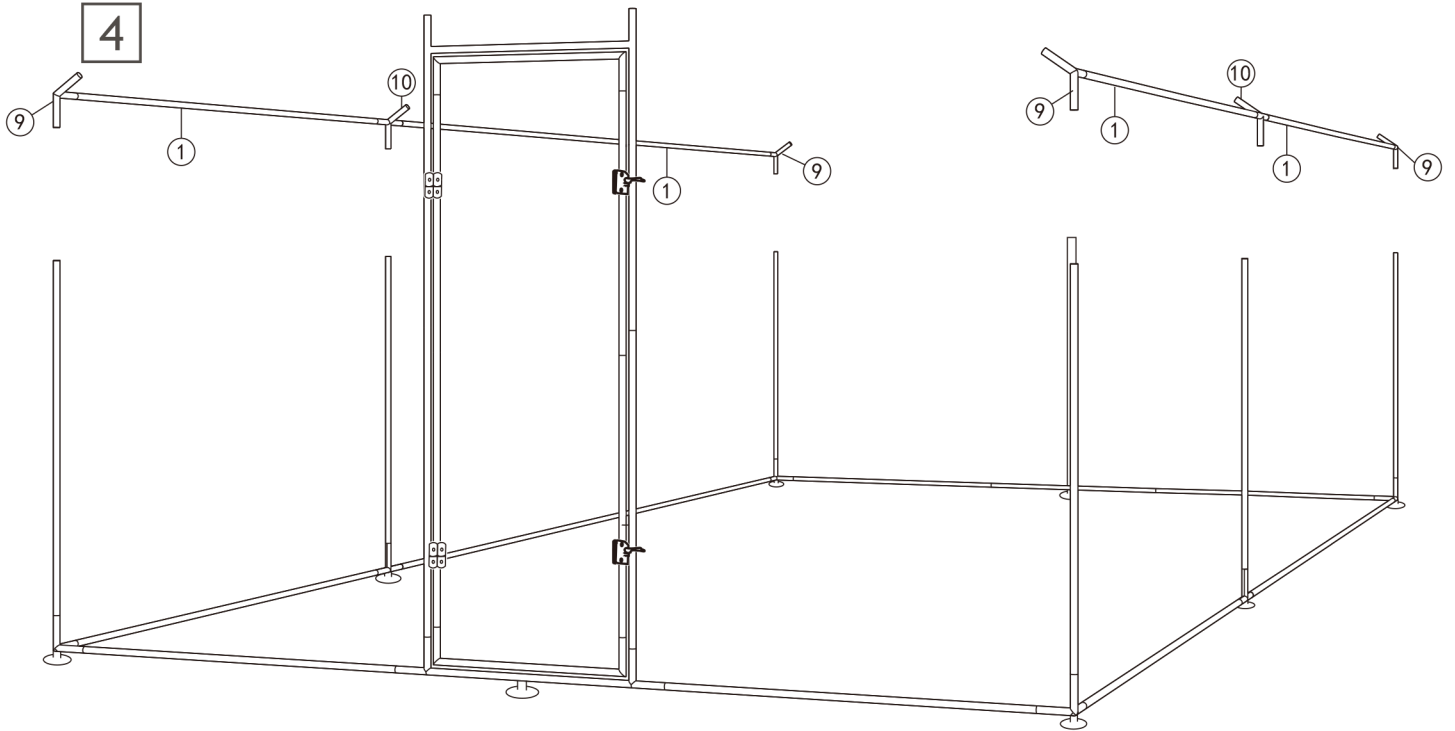

1 x4		9 x4		10 x2	
------	--	------	--	-------	--

5

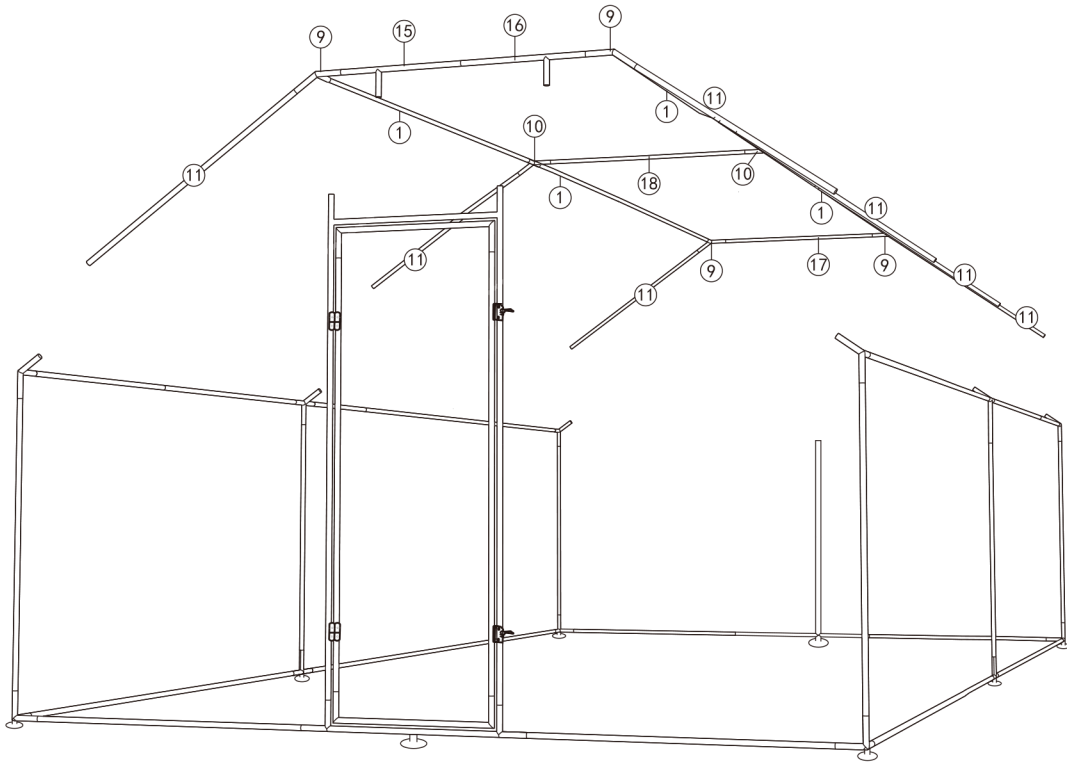

① x4				
⑨ x4		⑩ x2		⑪ x6
				⑮ x1
⑯ x1				⑰ x1
⑱ x1				

6

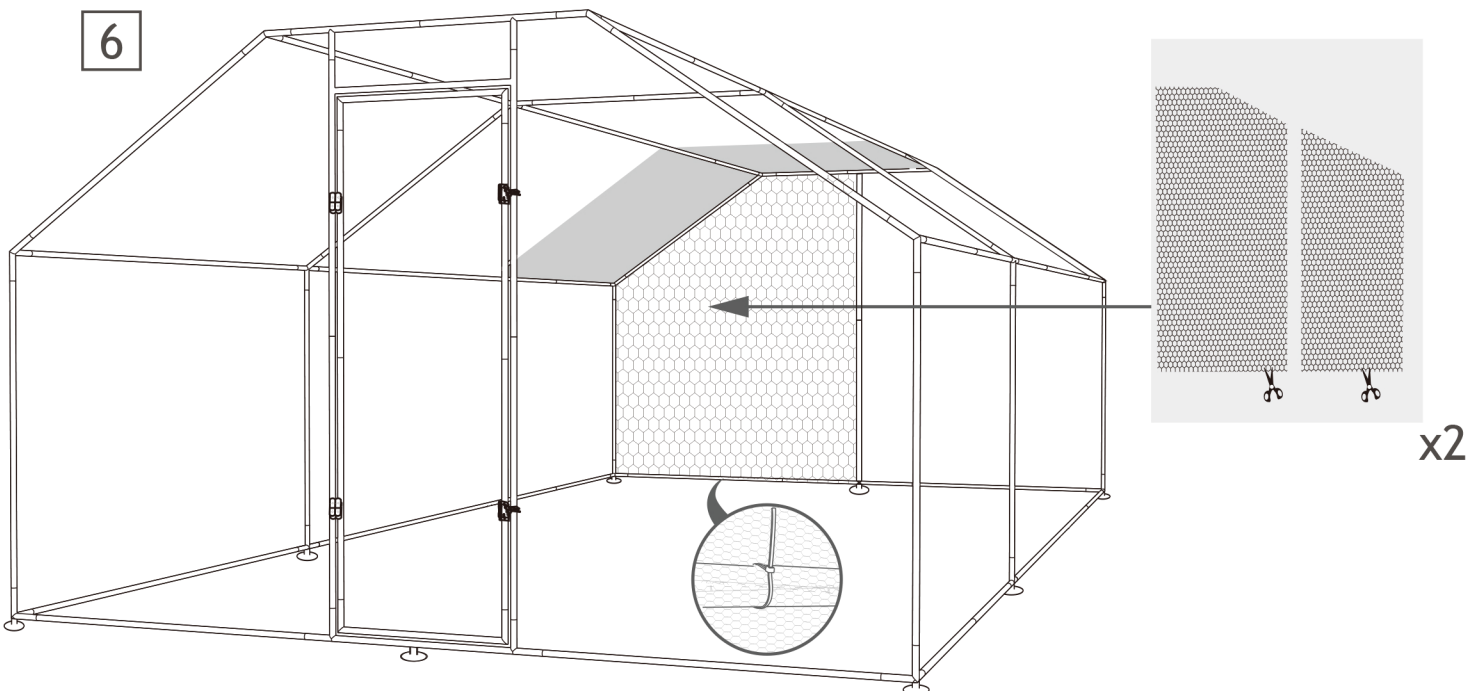

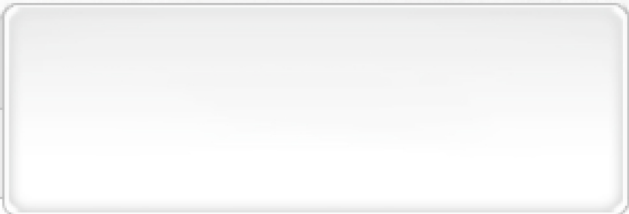

7

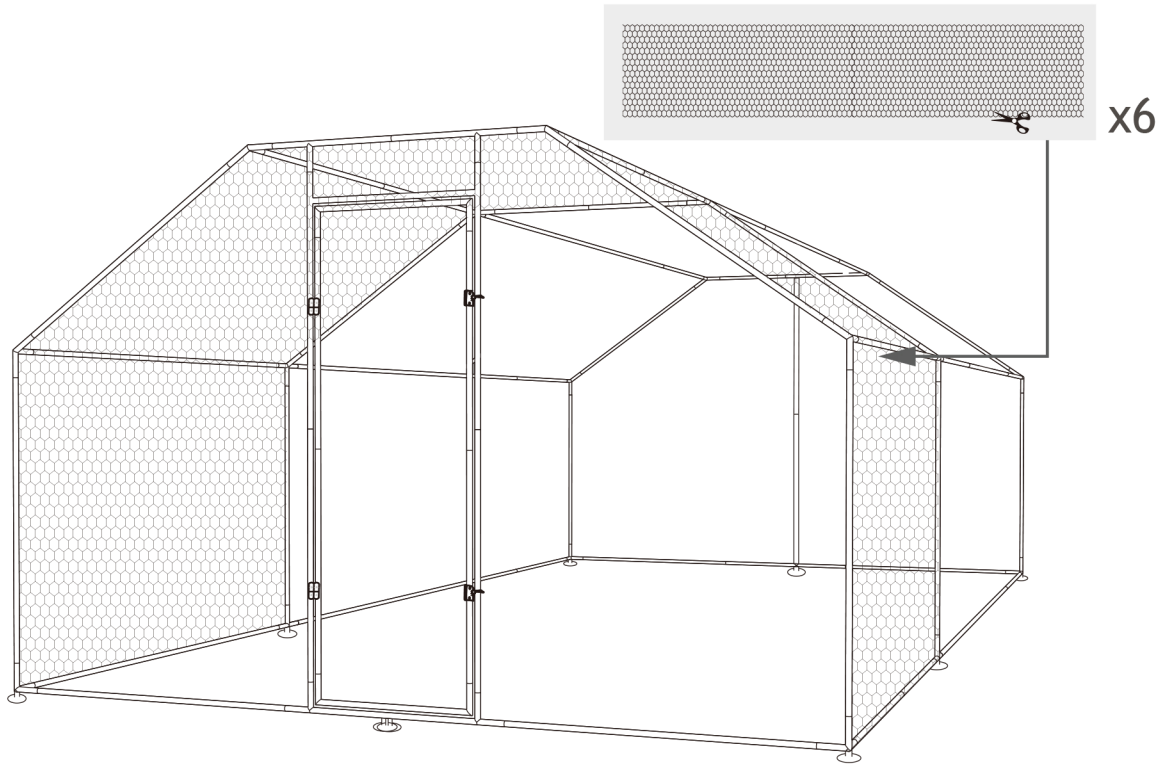

8

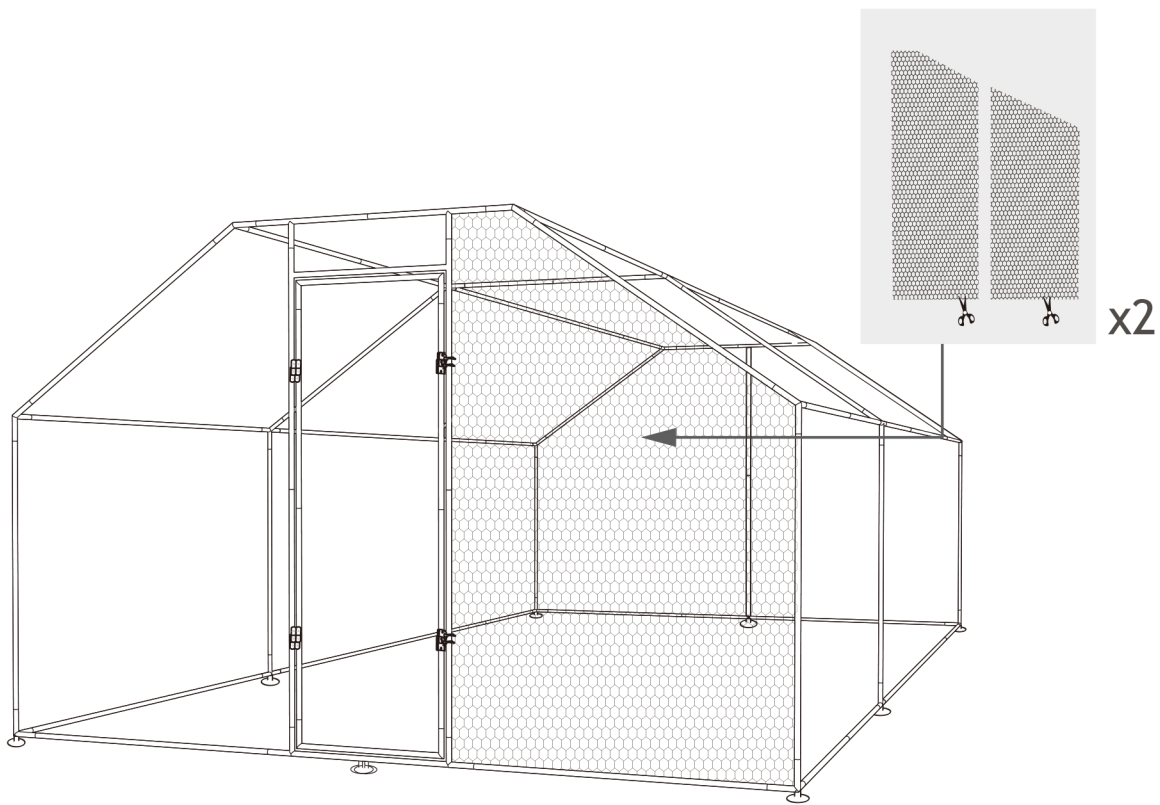

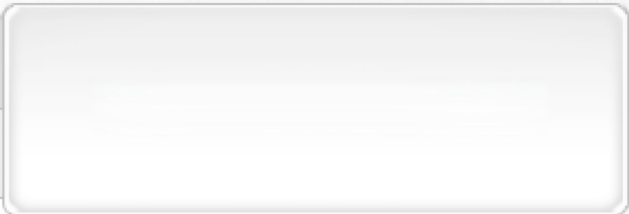

9

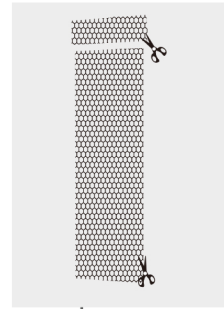
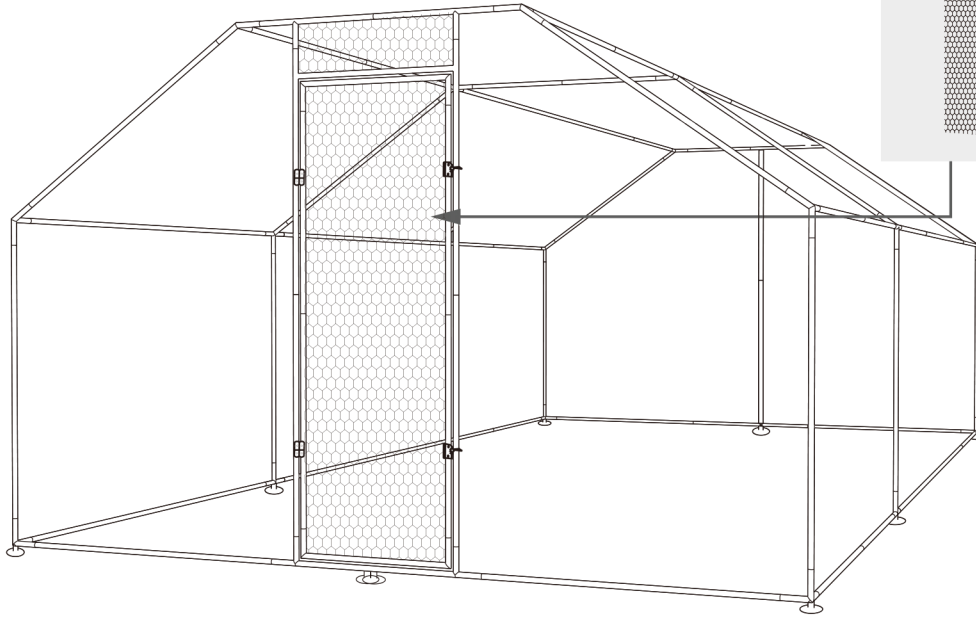

x1

10

