

Installation & Assembly

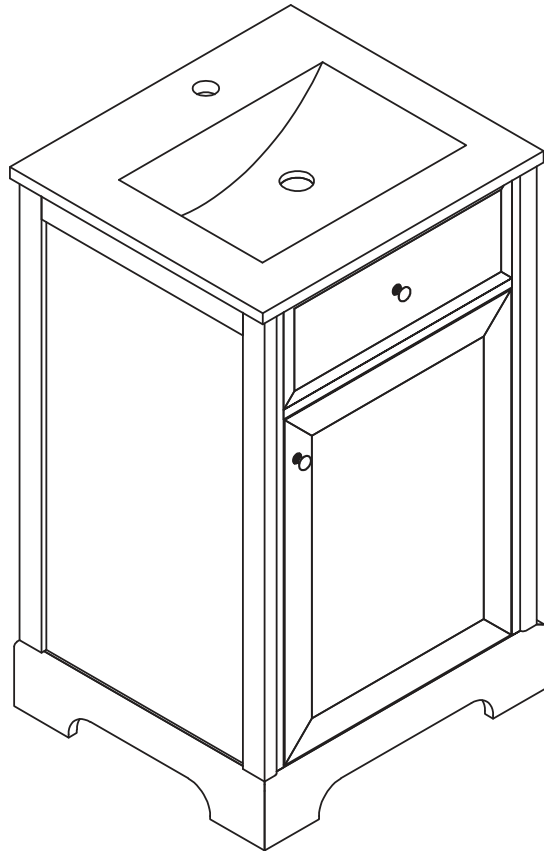

Thank you for purchasing this quality product. Be sure to check all package material carefully for small parts which may have come loose inside the carton during shipment. Separate, identify and count all parts and hardware. Compare with the parts list to be sure all parts are present.

"DO NOT TIGHTEN SCREWS UNTIL COMPLETELY ASSEMBLED"

Merci d'avoir acheté ce produit de qualité. Assurez-vous de vérifier soigneusement tout le matériel d'emballage pour détecter les petites pièces qui auraient pu se détacher à l'intérieur du carton pendant le transport. Séparez, identifiez et comptez toutes les pièces et le matériel. Comparez avec la liste des pièces pour vous assurer que toutes les pièces sont présentes.

"NE SERREZ PAS LES VIS AVANT D'ÊTRE COMPLÈTEMENT ASSEMBLÉES"

*** Use of power tool to assemble this product will invalidate any claim and damage this product making unsafe !!!**
*** Please assemble on a clean soft surface to avoid damage.**

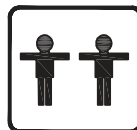

Tools Requi

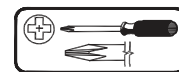

(Not included)

IMPORTANT:

PLEASE READ INSTRUCTION BEFORE STARTING THE ASSEMBLY
VEUILLEZ LIRE LES INSTRUCTIONS AVANT DE COMMENCER L'ASSEMBLAGE

Before Installation

Important - Please read these instructions fully before starting assembly

Thank you for purchasing this quality product. Be sure to check all packing materials carefully for small parts, which may have come loose inside the carton during shipment. Identify and count all items according to the PARTS LIST and/or HARDWARE LIST shown below. Check you have all the components and tools listed on the following pages.

- . We recommend that you assemble this product with the assistance of another person; this will make the assembly easier, and will help eliminate damage to the product or injury to persons during assembly.
- . Please do not over tighten screws or bolts until the assembly is completed.
- . Keep children and animal away from the work area, small parts could choke if swallowed.
- . Please put all parts on a non-abrasive floor before assembly, and follow the assembly steps to assemble your newly purchased product correctly and efficiently.

If you find that you have any trouble with assembly or missing or damaged parts please contact the seller.

Cam Lock Assembly Instructions

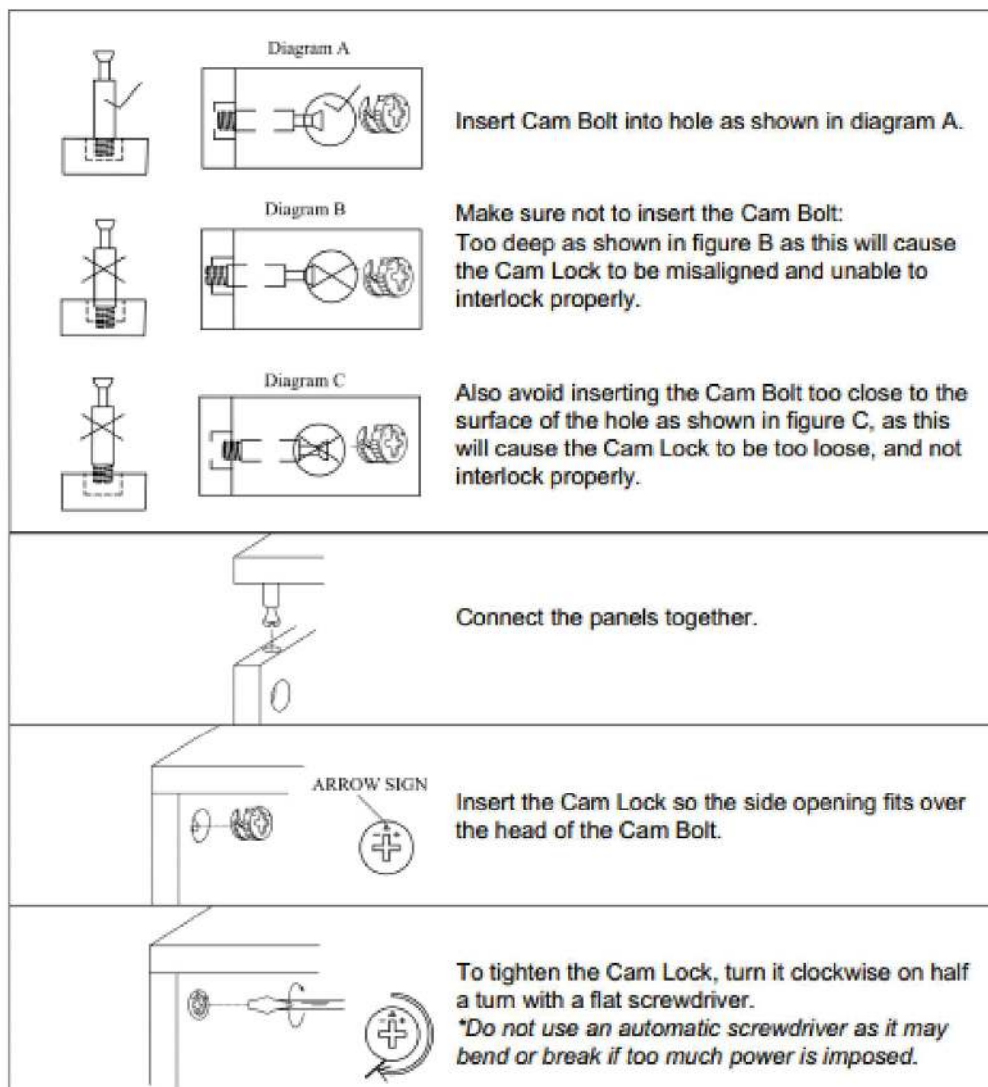

Before Installation

Important - Veuillez lire entièrement ces instructions avant de commencer l'assemblage.

Merci d'avoir acheté ce produit de qualité. Assurez-vous de vérifier soigneusement tous les matériaux d'emballage pour détecter les petites pièces qui pourraient s'être détachées à l'intérieur du carton pendant le transport. Identifiez et comptez tous les éléments conformément à la LISTE DES PIÈCES et/ou à la LISTE DU MATÉRIEL indiquée ci-dessous. Vérifiez que vous disposez de tous les composants et outils répertoriés dans les pages suivantes.

- Nous vous recommandons d'assembler ce produit avec l'aide d'une autre personne ; cela facilitera l'assemblage et aidera à éliminer les dommages au produit ou les blessures corporelles pendant l'assemblage.

- Veuillez ne pas trop serrer les vis ou les boulons jusqu'à ce que l'assemblage soit terminé.

- Tenir les enfants et les animaux éloignés de la zone de travail, les petites pièces pourraient s'étouffer en cas d'ingestion.

- Veuillez placer toutes les pièces sur un sol non abrasif avant l'assemblage et suivre les étapes d'assemblage pour assembler correctement et efficacement votre produit nouvellement acheté.

Si vous constatez des problèmes d'assemblage ou des pièces manquantes ou endommagées, veuillez contacter le vendeur.

Instructions d'assemblage du verrou à came

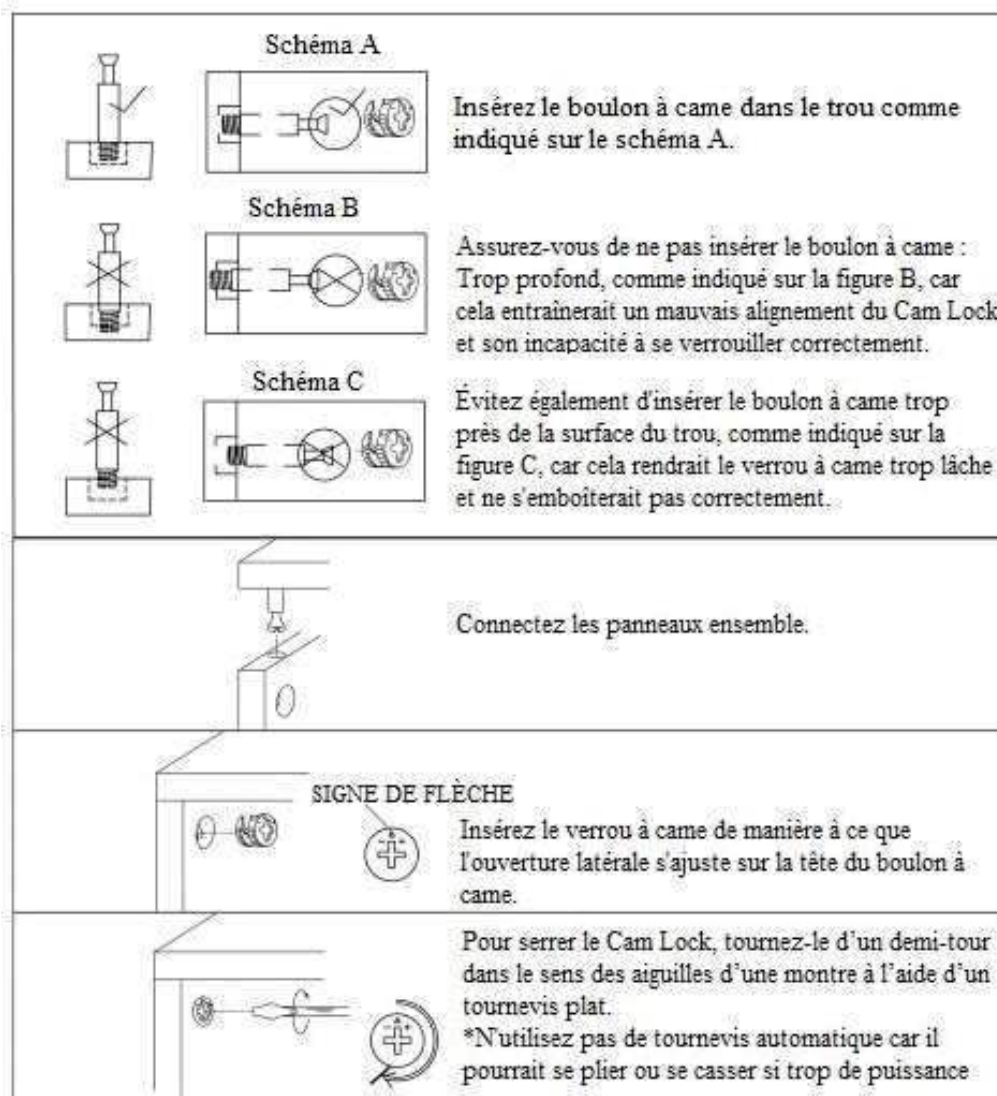



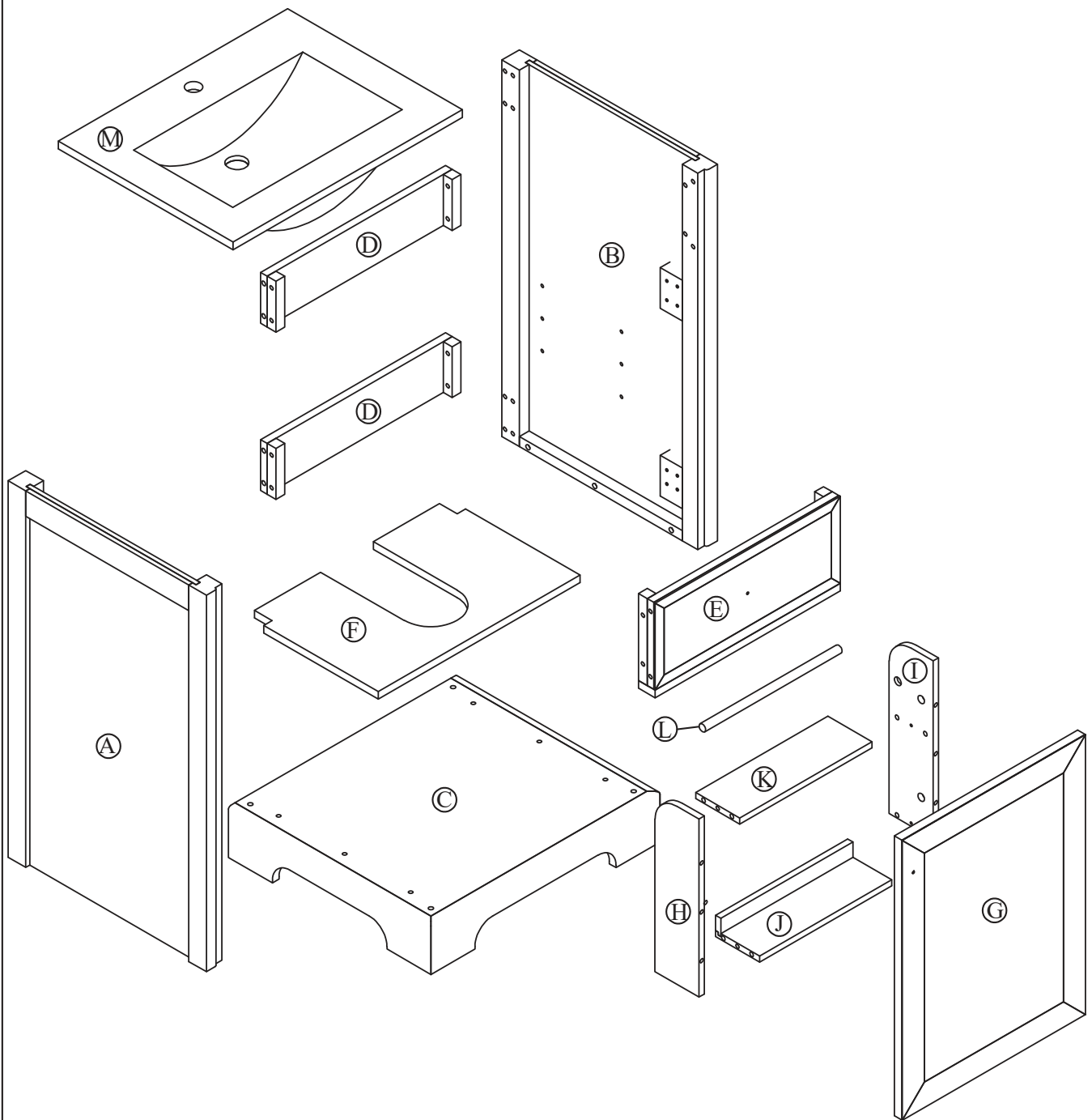

Detail View - VANITY
(Vue détaillée - Vanité)



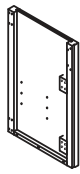
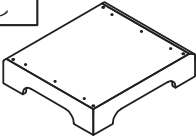
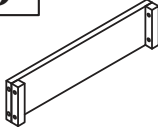
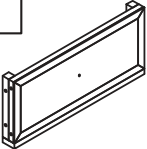
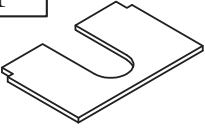
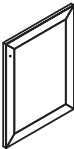

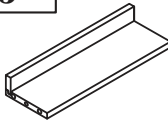
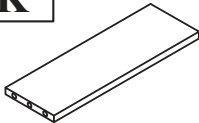

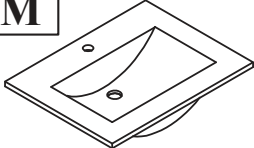

Identifying the Hardware - Identify the hardware using the illustrations below
(Identification du matériel - Identifiez le matériel à l'aide des illustrations ci-dessous)

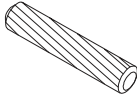
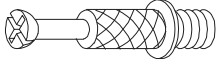
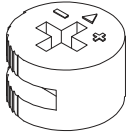
Part List (Liste des pièces)

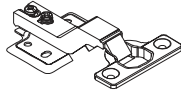
<p>A</p>  <p>Side Panel (L) - 1PC Panneau latéral</p>	<p>B</p>  <p>Side Panel (R) - 1PC Panneau latéral</p>
<p>C</p>  <p>Bottom frame - 1PC Cadre inférieur</p>	<p>D</p>  <p>Back rail - 2PCS Rail arrière</p>
<p>E</p>  <p>Front rail - 1PC Rail avant</p>	<p>F</p>  <p>Adjustable Shelf - 1PC Étagère réglable</p>
<p>G</p>  <p>Door - 1PC Porte</p>	<p>H</p>  <p>Left side of door detail- 1 PC Détail du côté gauche de la porte</p>
<p>I</p>  <p>Right side of door detail - 1 PC Détail du côté droit de la porte</p>	<p>J</p>  <p>Bottom Door Panel - 1PC Panneau de porte inférieur</p>
<p>K</p>  <p>Medium Drawer Panel - 1PC Panneau de tiroir inférieur</p>	<p>L</p>  <p>Wooden bars of door details- 1 PC Barres en bois des détails de la porte</p>
<p>M</p>  <p>Sink- 1PC Lavabo</p>	

Part List (Liste des pièces)

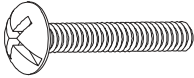
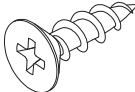
<p>1</p>  <p>Allen Bolts 1/4"x30 - 18PCS Boulons Allen</p>	<p>2</p>  <p>Wooden Ø8 x 30 - 28 PCS Enbois</p>	<p>3</p>  <p>Cam Lock Screws - 8PCS Vis de verrouillage à came</p>
<p>4</p>  <p>Cam Lock -8PCS Serrure à came</p>	<p>5</p>  <p>Screws M3.5x12 - 12PCS Vis White</p>	<p>6</p>  <p>Hinges - 2PCS Charnières</p>
<p>7</p>  <p>Allen key M4 - 1PC Clé Allen</p>	<p>8</p>  <p>Shelf Support - 4PCS Support d'étagère</p>	<p>9</p>  <p>Handle - 2PCS Poignée</p>
<p>10</p>  <p>Screws M4x20 - 2PCS boulons à tête de vis</p>	<p>11</p>  <p>Screws M3.5x12 - 4PCS Vis Rainbow</p>	

ASSEMBLY TOOLS REQUIRED (NOT INCLUDED)

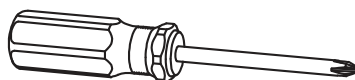

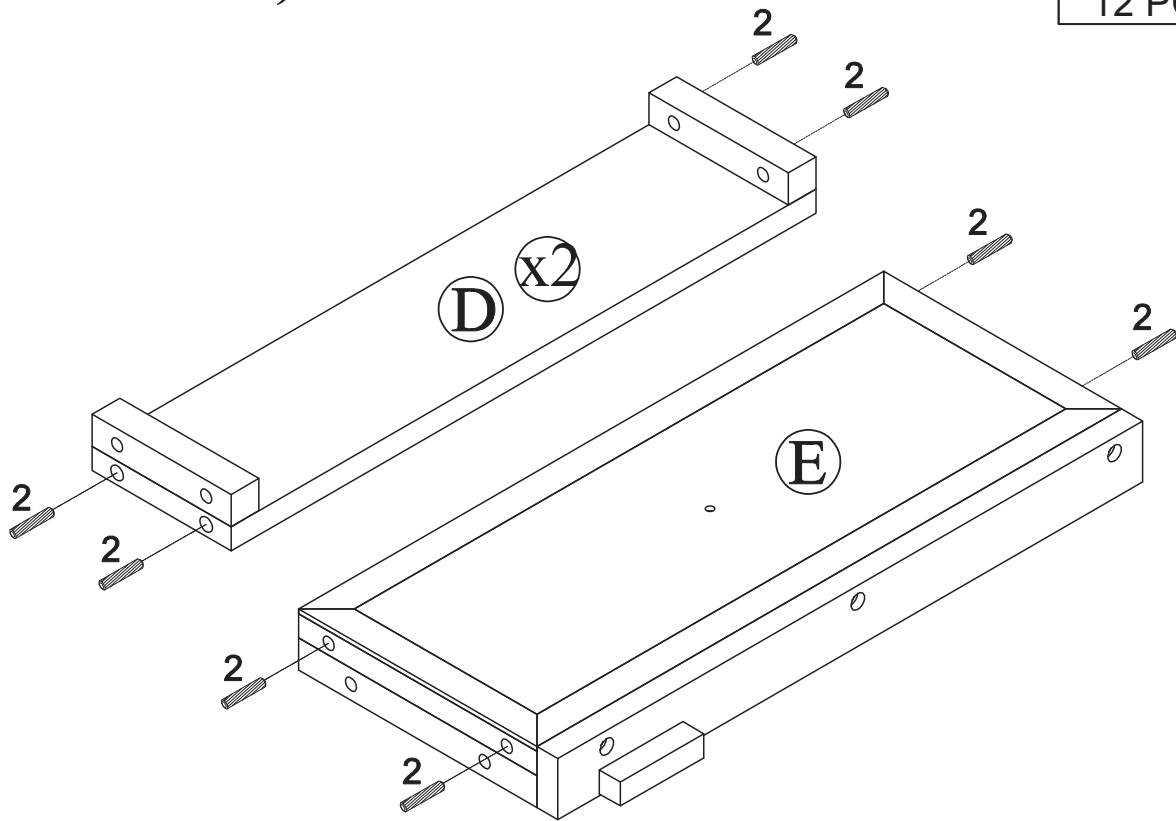

STEP: 1
(ÉTAPE : 1)

2	
Ø8 X 30	
12 PCS	



STEP: 2
(ÉTAPE : 2)

7		1	
M4		1/4 X 30	
1 PC		6 PCS	

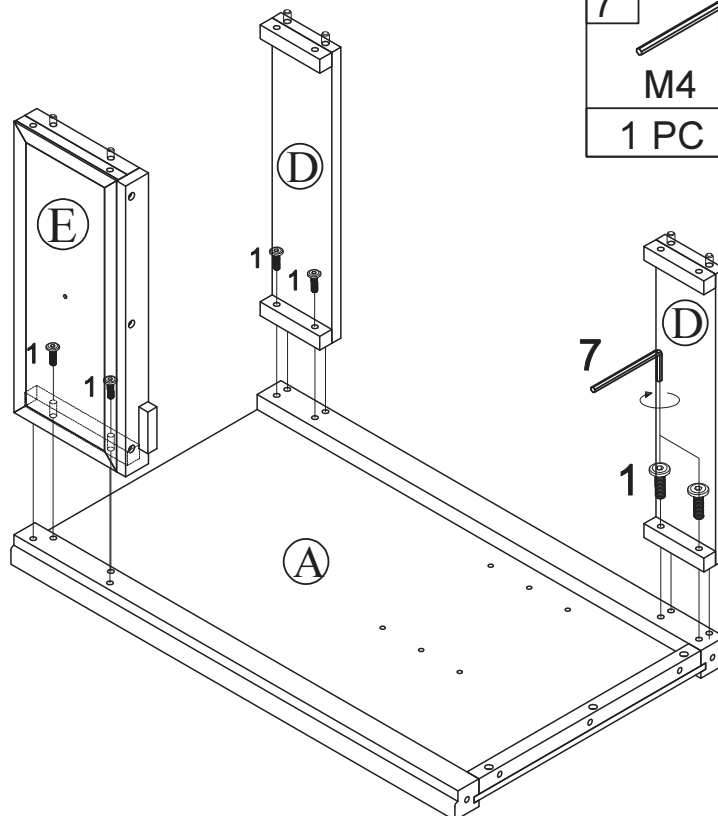

STEP: 3

(ÉTAPE : 3)

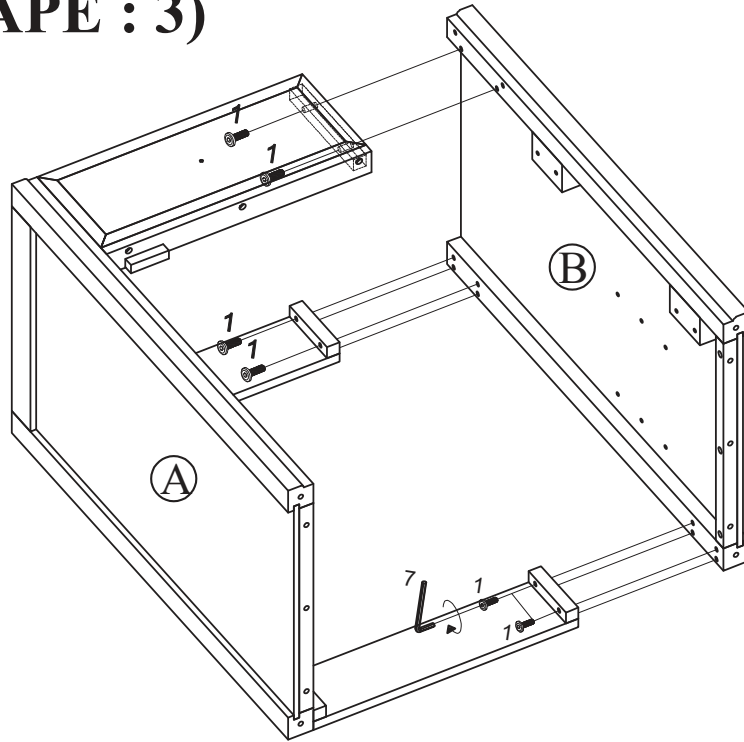

7		1	
	M4		1/4 X 30
	1 PC		6 PCS

STEP: 4

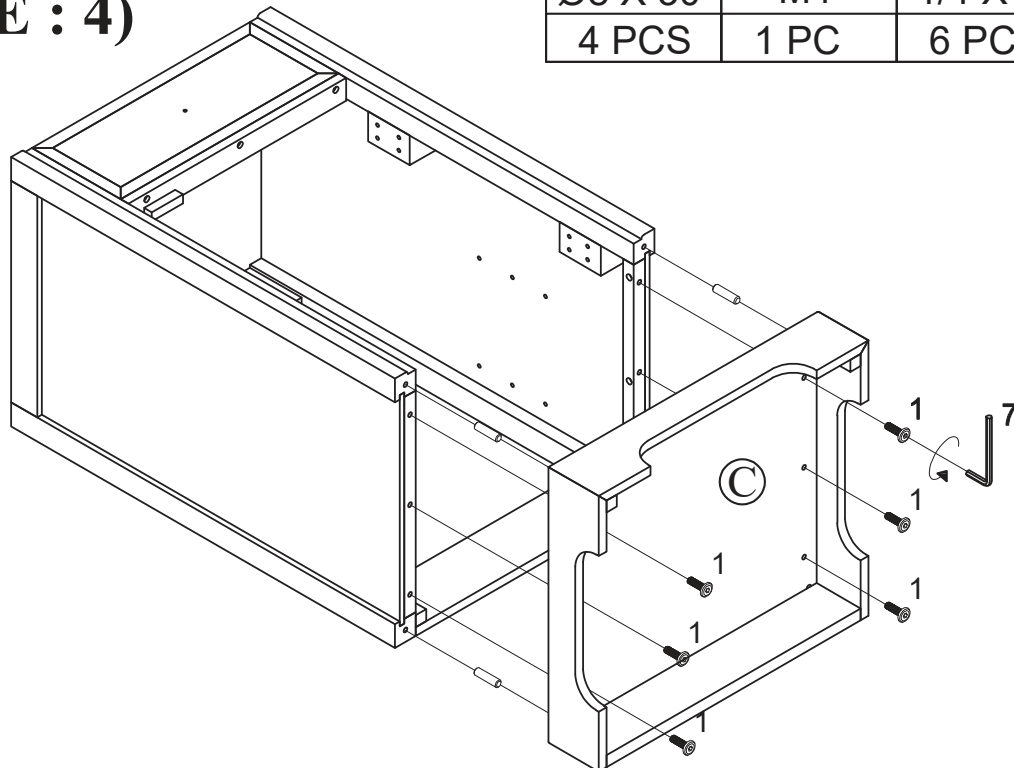

(ÉTAPE : 4)



2		7		1	
	Ø8 X 30		M4		1/4 X 30
	4 PCS		1 PC		6 PCS

STEP: 5

(ÉTAPE : 5)

3	2
	
4 PCS	Ø8 X 30 8 PCS

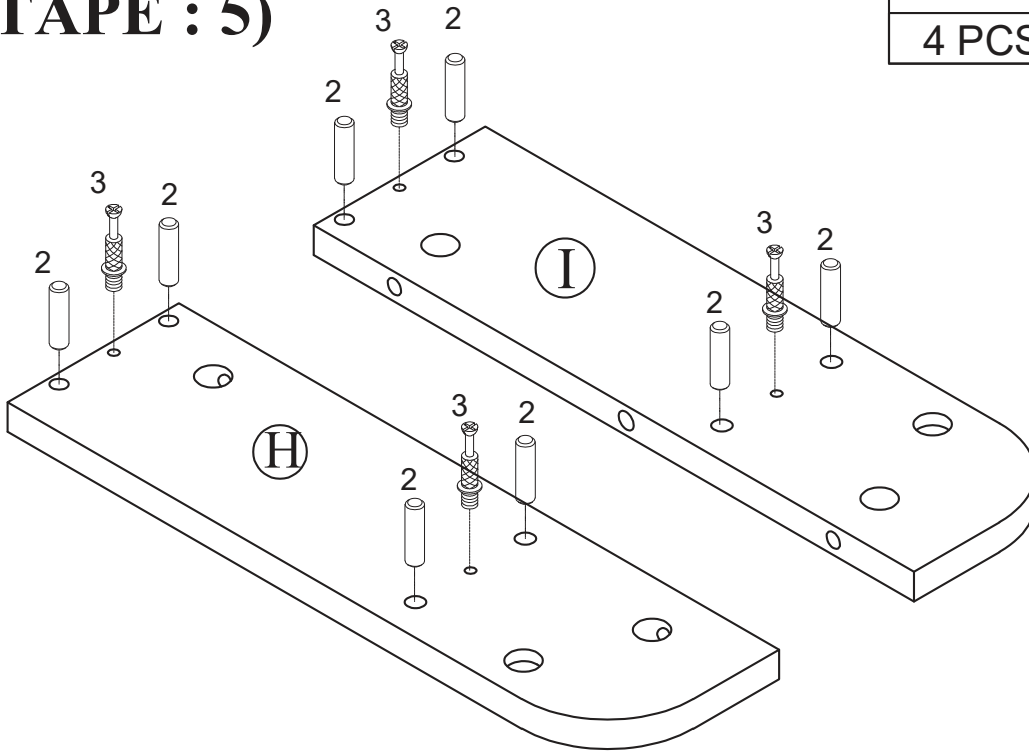

STEP: 6



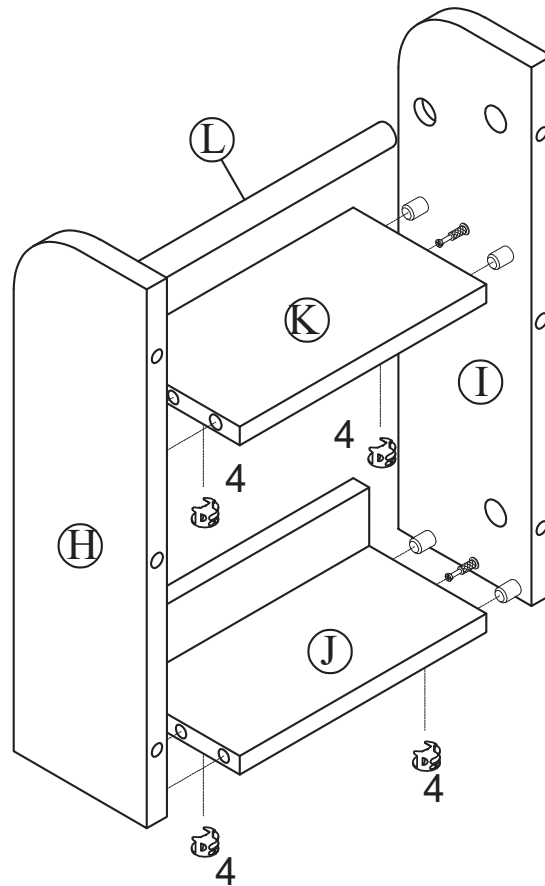

(ÉTAPE : 6)

4

4 PCS

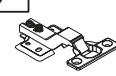

STEP: 7

(ÉTAPE : 7)

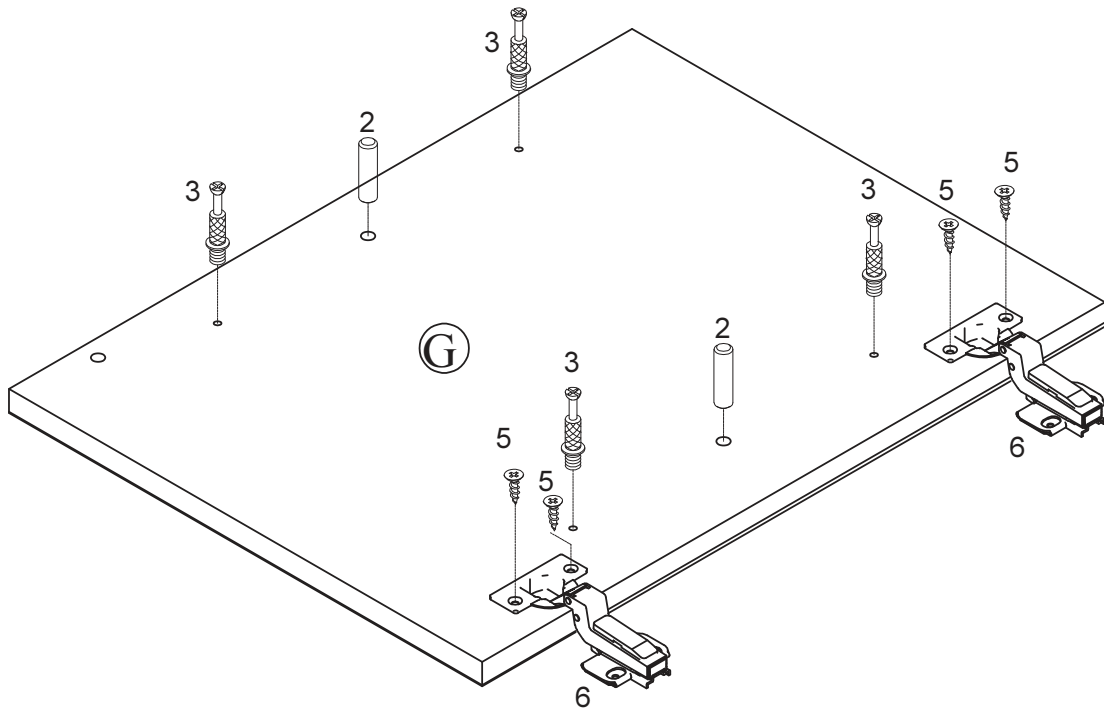
3		2		6		5	
	Ø8 X 30						M3.5 X 12
4 PCS		2 PCS		2 PCS		4 PCS	



STEP: 8

(ÉTAPE : 8)

4	
4 PCS	

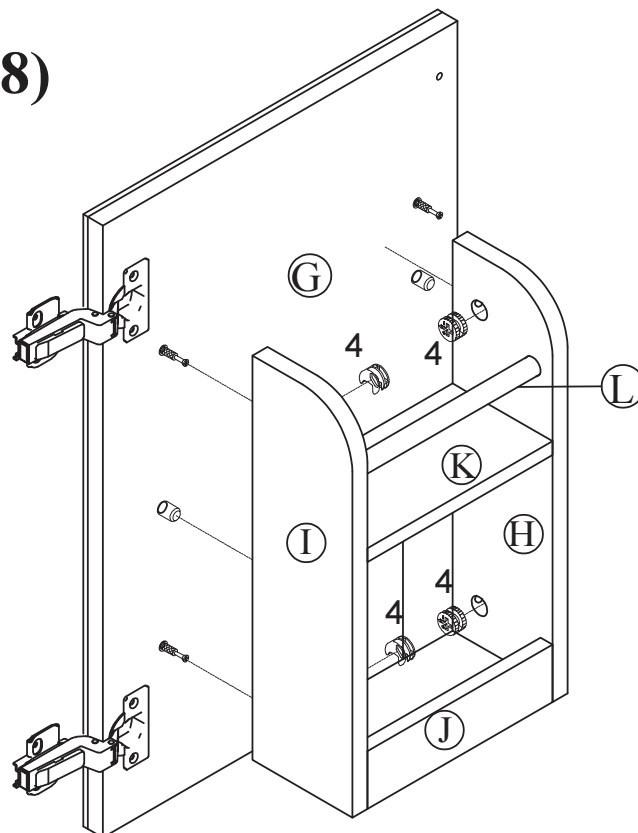

STEP: 9
(ÉTAPE : 9)

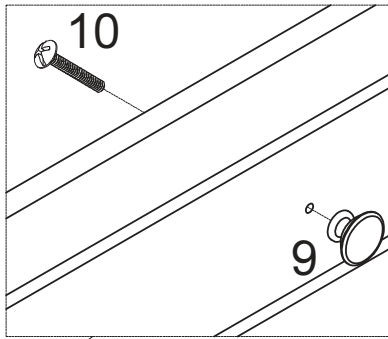
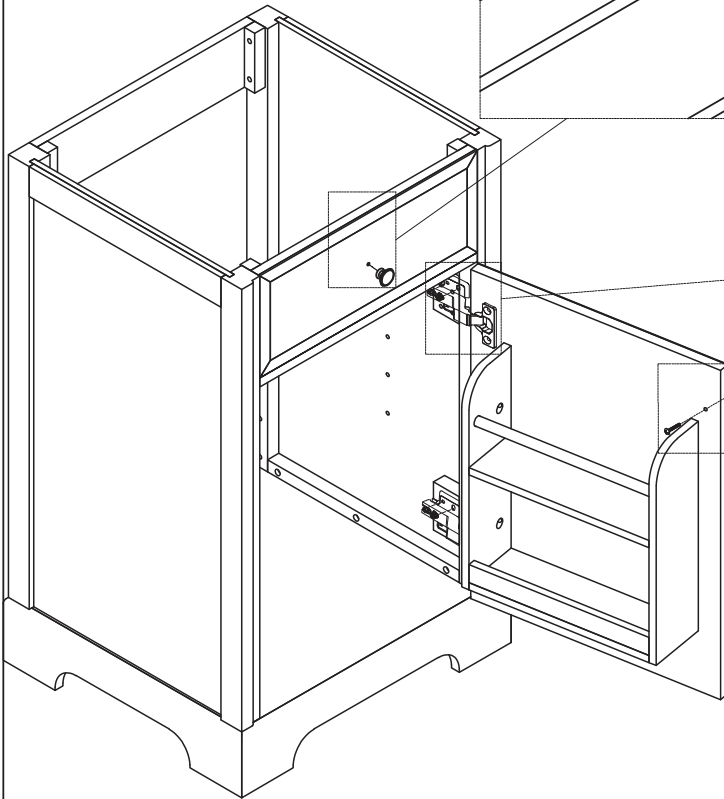

9		10	
2 PCS		M4 X20	
2 PCS		2 PCS	

5	
M3.5 X 12	
8 PCS	

(X2)

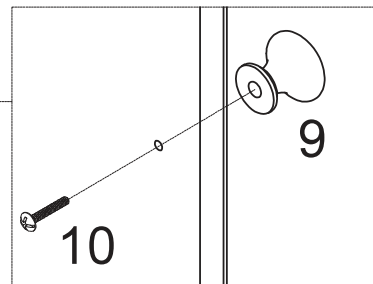

STEP: 10
(ÉTAPE : 10)

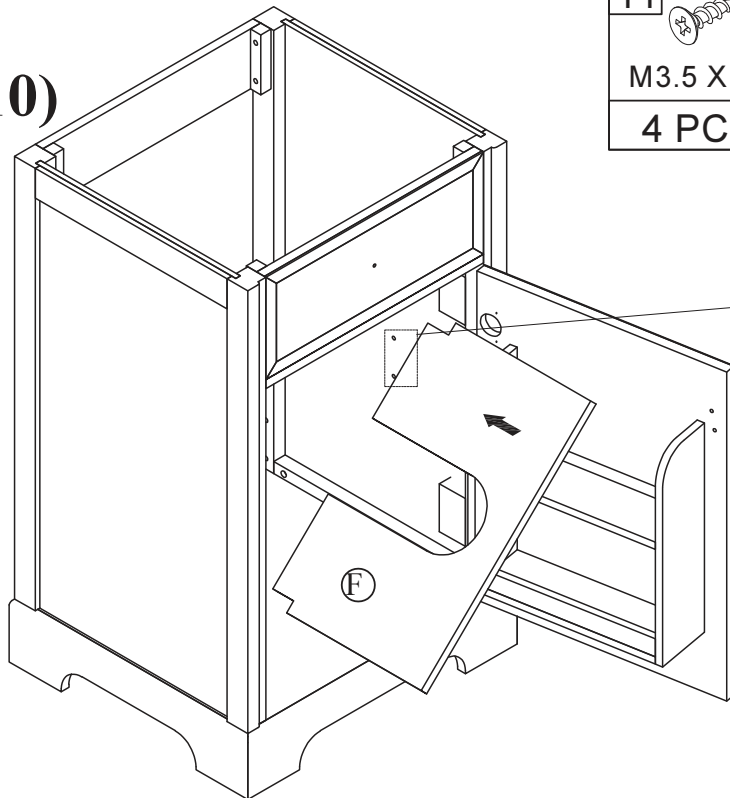

11		8	
M3.5 X 12			
4 PCS		4 PCS	

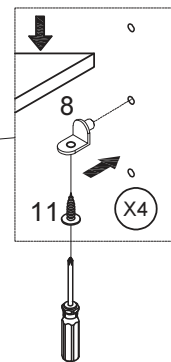

STEP:11

(ÉTAPE : 11)

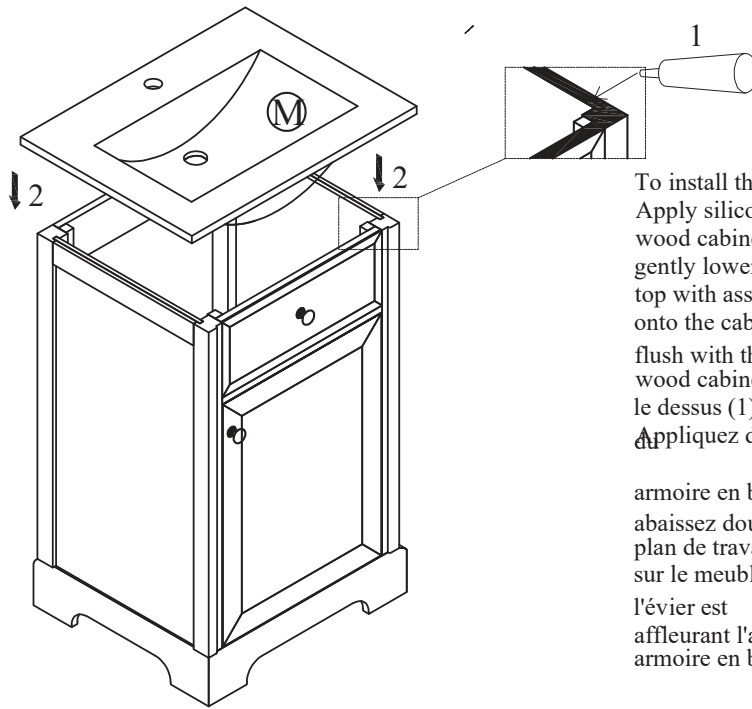

To install the Top (1) to the vanity (2). Apply silicone caulk to the top edge of the wood cabinet. With the help of another adult, gently lower the Sink top with assembled sink onto the cabinet. Make sure the Sink top is flush with the back side of the wood cabinet and the wood cabinet left and right side walls. Pour installer le dessus (1) sur la vanité (2).



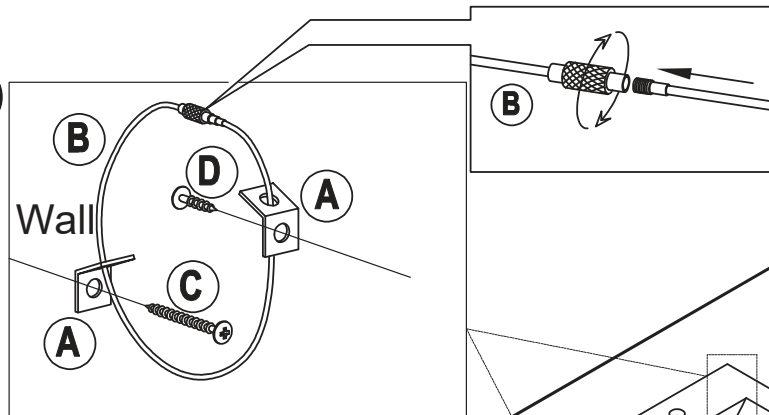

Appliquez du mastic silicone sur le bord supérieur armoire en bois. Avec l'aide d'un autre adulte, abaissez doucement l'évier plan de travail avec évier assemblé sur le meuble. Assurez-vous que le dessus de l'évier est affleurant l'arrière de l'armoire en bois et le armoire en bois parois latérales gauche et droite.

STEP: 12

(ÉTAPE : 12)



Hardware list: (Anti tipping kit 2 set in the bag)

<p>A</p>  <p>Brackets - 04pcs</p>	<p>B</p>  <p>Steel cables - 02pcs</p>
<p>C</p>  <p>Screws - 02pcs</p>	<p>D</p>  <p>Screws - 02pcs</p>
<p>E</p>  <p>wall anchor - 02pcs</p>	

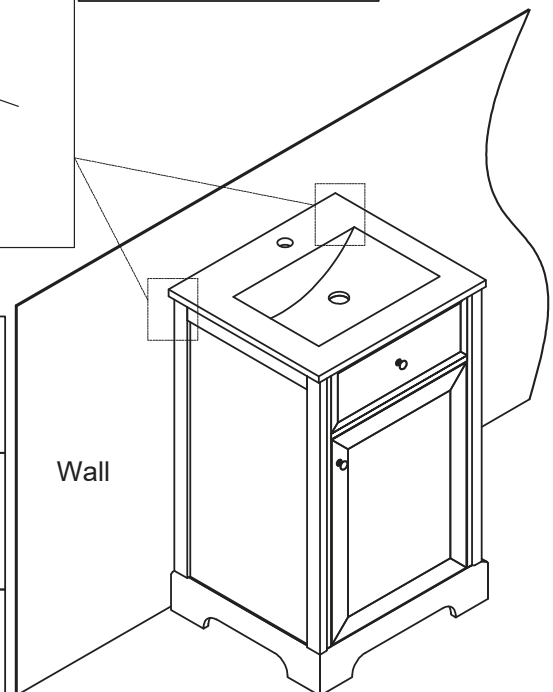

HINGE ADJUSTMENTS

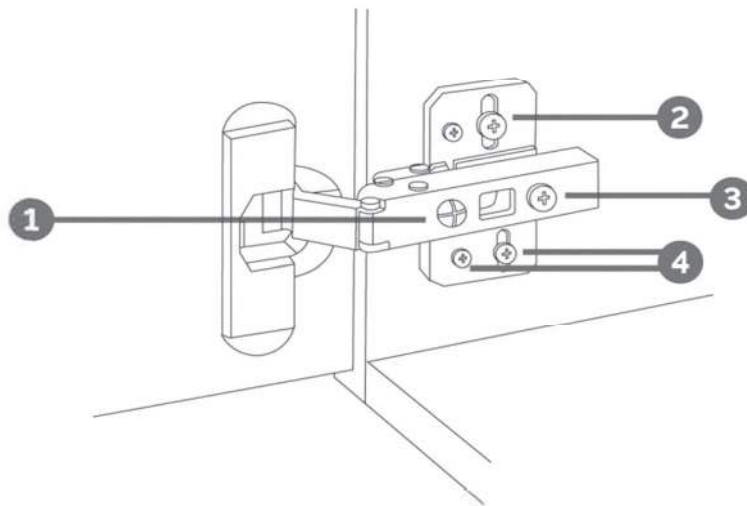

1 Sideways / Tilt adjustment

Turn the screw
clockwise to move the door further away from
the side of the cabinet
anticlockwise to move the door closer to the
side of the cabinet

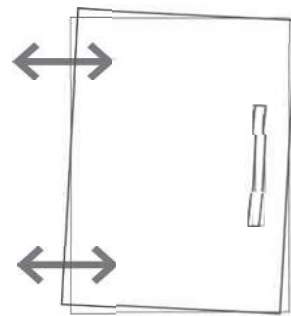

2 4 Height adjustment

While supporting the weight of the door, turn the
screws
clockwise to move the door up
anticlockwise to move the door down

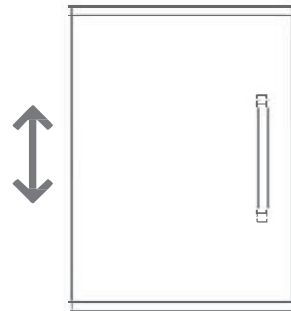

3 Forward and back adjustment

If the gap between the back of the door and the
cabinet is too small, and the door may not close
fully. Turn the screw
clockwise to decrease the gap between the
door and the cabinet
anticlockwise to increase the gap between the
door and the cabinet

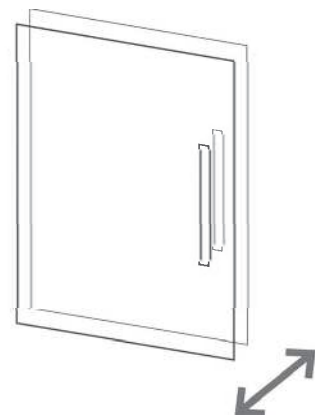

RÉGLAGES DES CHARNIÈRES

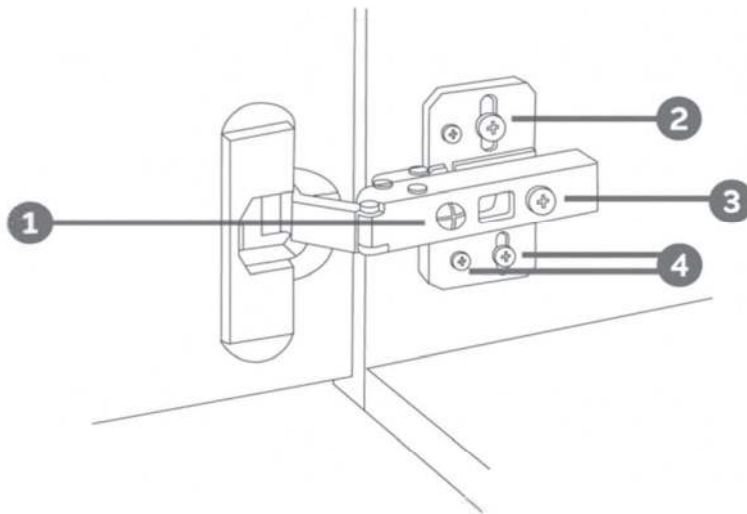

① De côté / Réglage de l'inclinaison

Tournez la vis
dans le sens des aiguilles d'une montre pour éloigner
la porte
le côté du meuble
dans le sens inverse des aiguilles d'une montre pour
rapprocher la porte du
côté du meuble

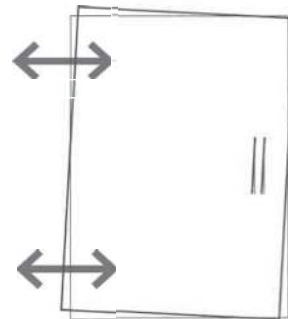

② ④ Réglage de la

Tout en supportant le poids de la porte, tournez les vis
dans le sens des aiguilles d'une montre pour déplacer la
porte vers le haut
dans le sens inverse des aiguilles d'une montre pour
abaisser la porte



③ Réglage vers l'avant et vers l'arrière

Si l'espace entre l'arrière de la porte et le
l'armoire est trop petite et la porte risque de ne pas se
fermer complètement. Tournez la vis
dans le sens des aiguilles d'une montre pour diminuer
l'écart entre la porte et l'armoire
dans le sens inverse des aiguilles d'une montre pour
augmenter l'écart entre la porte et l'armoire.

