

SKU N651P366138-N651P366139-N651P366140

DE: Installationsanleitung
UK: Installation Instruction
FR: Instruction d'installation
IT: Istruzioni di installazione
ES: Instrucciones de instalación
NL: Installatie-instructies
SE: Installationsanvisningar
PL: Instrukcja instalacji

Unser Produkt wird Ihnen in 3 Paketen geliefert. Die Lieferzeiten dieser 3 Pakete können abweichen, bitte haben Sie etwas Geduld und vielen Dank für Ihr Verständnis.

Our product will be delivered to you in 3 packages. The delivery times of these 3 packages may differ, please be patient and thank you for your understanding.

Notre produit vous sera livré en 3 colis. Les délais de livraison de ces 3 colis peuvent différer, soyez patient et merci pour votre compréhension.

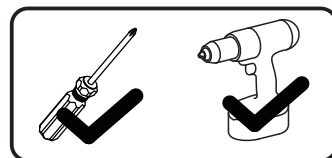
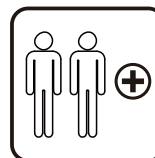
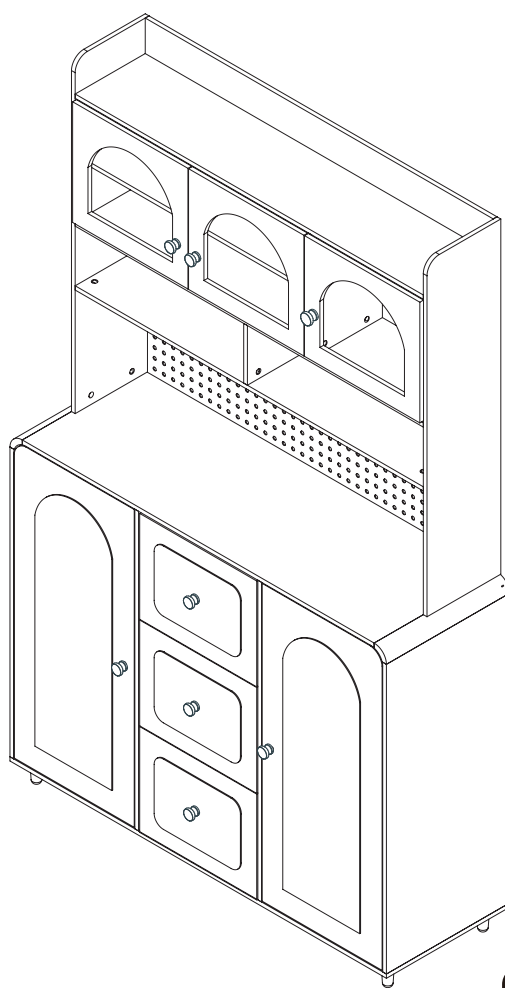

EN_IMPORTANT, RETAIN FOR FUTURE REFERENCE: READ CAREFULLY.

FR_IMPORTANT: A LIRE ATTENTIVEMENT ET À CONSERVER POUR CONSULTATION ULTÉRIEURE.

ES_IMPORTANTE, LEA Y GUARDE PARA FUTURAS REFERENCIAS.

DE_„, WICHTIG! SORGFÄLTIG LESEN UND FÜR SPÄTER NACHSCHLAGEN AUFBEWAHREN.“

IT_IMPORTANTE! CONSERVARE IL PRESENTE MANUALE PER FUTURO RIFERIMENTO E LEGGERLO ATTENTAMENTE.



DE

Warnung: Die maximale Belastbarkeit dieses Möbels beträgt: 50 kg, bitte nicht überlasten!

EN

Warning: The maximum load-bearing capacity of this furniture is: 50 kg, please do not overload!

FR

Avertissement : La capacité de charge maximale de ce meuble est de : 50 kg, merci de ne pas surcharger !

IT

Attenzione: la capacità di carico massima di questo mobile è: 50 kg, non sovraccaricare!

ES

Advertencia: La capacidad máxima de carga de este mueble es: 50 kg, ¡no lo sobrecargue!



[DE]

Warnung: Lesen Sie die Anleitung vor dem Zusammenbau bitte vollständig durch. Überprüfen Sie, ob Sie alle auf den Seiten aufgeführten Komponenten und Werkzeuge haben.

Warnung: Legen Sie alle Teile auf eine ebene Fläche. Legen Sie eine weiche Decke oder Ähnliches darunter, um sie vor Kratzern oder Flecken zu schützen. Vermeiden Sie es, Komponenten über den Boden zu ziehen oder zu schieben.

Warnung: Überprüfen Sie regelmäßig alle Beschläge und Befestigungen, um sicherzustellen, dass sie sicher sind und um Unfälle zu vermeiden. Wenn Teile fehlen, kaputt, beschädigt oder abgenutzt sind, verwenden Sie das Produkt nicht weiter, bis es mit vom Hersteller autorisierten Teilen repariert wurde.

Warnung: Lassen Sie Kinder nicht auf die Möbel klettern, da dies zum Umkippen und zu schweren Verletzungen führen kann. Bauen Sie die Möbel außerhalb der Reichweite von Kindern zusammen.

Warnung: Stellen Sie die Möbel nicht in die Nähe von Feuerquellen oder heißen Gegenständen, um Brandgefahr zu vermeiden.

Warnung: Reinigen Sie die Möbel mit einem feuchten Tuch oder Alkohol. Verwenden Sie keine Reinigungsmittel mit ätzenden Chemikalien.

[EN]

Warning: Please read instructions fully before starting assembly. Check you have all the components and tools listed on pages.

Warning: Please place all parts on a flat surface. Place a soft blanket or similar underneath to protect against scratches or stains. Avoid dragging or sliding components across the floor.

Warning: Regularly check all fittings and fastenings to ensure they are secure and to prevent accidents. If any parts are missing, broken, damaged, or worn, discontinue use of the product until repairs have been made using factory authorized parts.

Warning: Do not allow children to climb on the furniture as this may result in tipping and serious personal injury. Assemble the furniture away from the reach of children.

Warning: Do not place furniture close to fire sources or high-temperature objects to avoid the risk of fire.

Warning: Clean furniture with a damp cloth or alcohol, avoid using cleaning agents containing corrosive chemicals.

[FR]

Avertissement : Veuillez lire entièrement les instructions avant de commencer l'assemblage. Vérifiez que vous disposez de tous les composants et outils répertoriés sur les pages.

Avertissement : Veuillez placer toutes les pièces sur une surface plane. Placez une couverture douce ou similaire en dessous pour les protéger des rayures ou des taches. Évitez de faire glisser les composants sur le sol.

Avertissement : Vérifiez régulièrement tous les raccords et fixations pour vous assurer qu'ils sont bien fixés et pour éviter les accidents. Si des pièces manquent, sont cassées, endommagées ou usées, cessez d'utiliser le produit jusqu'à ce que des réparations aient été effectuées à l'aide de pièces autorisées par l'usine.

Avertissement : Ne laissez pas les enfants grimper sur les meubles car cela pourrait entraîner un basculement et des blessures graves. Assemblez les meubles hors de portée des enfants.

Avertissement : Ne placez pas les meubles à proximité de sources de feu ou d'objets à haute température pour éviter tout risque d'incendie.

Avertissement : Nettoyez les meubles avec un chiffon humide ou de l'alcool, évitez d'utiliser des produits de nettoyage contenant des produits chimiques corrosifs.



[IT]

Attenzione: leggere attentamente le istruzioni prima di iniziare il montaggio. Verificare di avere tutti i componenti e gli strumenti elencati nelle pagine.

Attenzione: posizionare tutte le parti su una superficie piana. Posizionare una coperta morbida o simile sotto per proteggere da graffi o macchie. Evitare di trascinare o far scivolare i componenti sul pavimento.

Attenzione: controllare regolarmente tutti i raccordi e i dispositivi di fissaggio per assicurarsi che siano sicuri e per prevenire incidenti. Se alcune parti sono mancanti, rotte, danneggiate o usurate, interrompere l'uso del prodotto fino a quando non siano state eseguite le riparazioni utilizzando parti autorizzate dalla fabbrica.

Attenzione: non consentire ai bambini di arrampicarsi sui mobili poiché ciò potrebbe causare ribaltamenti e gravi lesioni personali. Montare i mobili lontano dalla portata dei bambini.

Attenzione: non posizionare i mobili vicino a fonti di fuoco o oggetti ad alta temperatura per evitare il rischio di incendio.

Attenzione: pulire i mobili con un panno umido o alcol, evitare di utilizzare detergenti contenenti sostanze chimiche corrosive.

[ES]

Advertencia: Lea las instrucciones completamente antes de comenzar el montaje. Compruebe que tiene todos los componentes y herramientas que se enumeran en las páginas.

Advertencia: Coloque todas las piezas sobre una superficie plana. Coloque una manta suave o algo similar debajo para protegerlas de rayones o manchas. Evite arrastrar o deslizar los componentes por el piso.

Advertencia: Verifique regularmente todos los accesorios y fijaciones para asegurarse de que estén seguros y evitar accidentes. Si falta alguna pieza, está rota, dañada o desgastada, deje de usar el producto hasta que se hayan realizado las reparaciones con piezas autorizadas de fábrica.

Advertencia: No permita que los niños se suban a los muebles, ya que esto puede provocar que se vuelquen y lesiones personales graves. Monte los muebles fuera del alcance de los niños.

Advertencia: No coloque los muebles cerca de fuentes de fuego u objetos de alta temperatura para evitar el riesgo de incendio.

Advertencia: Limpie los muebles con un paño húmedo o alcohol, evite usar agentes de limpieza que contengan químicos corrosivos.

Importeur	Decobus Handel GmbH		
Adresse	Innungsstraße 9, 21244 Buchholz, Deutschland		
URL	https://www.decobusgroup.de		
Hersteller	Onetime Furniture Limited		
Adresse	ROOM 602, 6/F, KAI YUE COMMERCIAL BUILDING, NO.2C, ARGYLE STREET, MONGKOK KOWLOON, HONG KONG		
Email/URL	84973089@qq.com		
Partienummer	C811UZH20250811TA		
Hergestellt in	HERGESTELLT IN CHINA		
<table border="1"><tr><td>EC</td><td>REP</td></tr></table>	EC	REP	Decobus Handel GmbH Innungsstraße 9, 21244 Buchholz, Deutschland https://www.decobusgroup.de
EC	REP		



DE

1. Die maximale Tragfähigkeit der Oberplatte beträgt 330 kg, bitte nicht überladen.
2. Lassen Sie Kinder nicht auf Möbeln klettern, da dies zu Umstürzen und schweren Verletzungen führen kann.
3. Um die Sicherheit zu gewährleisten, installieren Sie bitte gemäß der Anleitung und ziehen Sie bei Bedarf Fachleute hinzu.
4. Stellen Sie Möbel nicht in die Nähe von Feuerquellen oder heißen Gegenständen, um Brandgefahr zu vermeiden.
5. Stellen Sie Möbel nicht in feuchten Umgebungen auf, um Materialschäden zu verhindern.
6. Überprüfen Sie regelmäßig alle Verbindungs- und Befestigungselemente, um sicherzustellen, dass sie fest sitzen und Unfälle zu vermeiden.
7. Dieses Produkt ist mit einem Kipp-Schutz ausgestattet, installieren Sie diesen Schutz, um Verletzungen durch Umstürzen zu vermeiden.

UK

1. The maximum weight capacity of the top panel is 330kg; please do not overload.
2. Do not allow children to climb on furniture, as this may cause tipping and serious injury.
3. To ensure safety, please install correctly according to the instructions and seek professional assistance if necessary.
4. Do not place furniture near fire sources or hot objects to avoid fire hazards.
5. Do not place furniture in damp environments to prevent material damage.
6. Regularly check all connectors and fasteners to ensure they are secure to prevent accidents.
7. This product comes with a anti-tipping device; install this device to prevent injuries from tipping.

FR

1. La charge maximale du panneau supérieur est de 330 kg, ne pas surcharger.
2. Ne laissez pas les enfants grimper sur les meubles, cela peut entraîner des basculements et des blessures graves.
3. Pour garantir la sécurité, installez correctement selon les instructions et demandez l'aide de professionnels si nécessaire.
4. Ne placez pas les meubles près de sources de chaleur ou d'objets chauds pour éviter les risques d'incendie.
5. Ne placez pas les meubles dans des environnements humides pour éviter d'endommager les matériaux.
6. Vérifiez régulièrement tous les connecteurs et les fixations pour vous assurer qu'ils sont bien serrés et éviter les accidents.
7. Ce produit est équipé d'un dispositif anti-basculement; installez ce dispositif pour éviter les blessures dues au basculement.

IT

1. La capacità massima del pannello superiore è di 330 kg; non sovraccaricare.
2. Non permettere ai bambini di arrampicarsi sui mobili, poiché ciò può causare ribaltamenti e gravi infortuni.
3. Per garantire la sicurezza, installare correttamente secondo le istruzioni e, se necessario, chiedere assistenza a professionisti.
4. Non posizionare i mobili vicino a fonti di calore o oggetti caldi per evitare rischi di incendio.
5. Non posizionare i mobili in ambienti umidi per prevenire danni ai materiali.
6. Controllare regolarmente tutti i connettori e le viti per assicurarsi che siano saldi e prevenire incidenti.
7. Questo prodotto è dotato di un dispositivo anti-ribaltamento; installare questo dispositivo per evitare infortuni da ribaltamento.

ES

1. La capacidad máxima del panel superior es de 330 kg; no sobrecargar.
2. No permita que los niños escalen los muebles, ya que esto puede causar volcaduras y lesiones graves.
3. Para garantizar la seguridad, instale correctamente según las instrucciones y busque ayuda profesional si es necesario.
4. No coloque los muebles cerca de fuentes de fuego u objetos calientes para evitar riesgos de incendio.
5. No coloque los muebles en ambientes húmedos para evitar daños en los materiales.
6. Revise regularmente todos los conectores y sujetadores para asegurarse de que estén seguros y prevenir accidentes.
7. Este producto viene con un dispositivo anti-vuelco; instale este dispositivo para prevenir lesiones por

vuelcos.

NL

1. De maximale draagcapaciteit van het bovenpaneel is 330 kg; niet overbelasten.
2. Laat kinderen niet op meubels klimmen, dit kan leiden tot omvallen en ernstige verwondingen.
3. Installeer correct volgens de instructies om de veiligheid te waarborgen, en schakel indien nodig professionele hulp in.
4. Plaats meubels niet in de buurt van vuurbronnen of warme objecten om brandgevaar te voorkomen.
5. Plaats meubels niet in vochtige omgevingen om materiaalschade te voorkomen.
6. Controleer regelmatig alle verbindingen en bevestigingsmiddelen om ervoor te zorgen dat ze stevig zijn en om ongevallen te voorkomen.
7. Dit product is uitgerust met een kantelbeveiliging; installeer dit apparaat om verwondingen door omvallen te voorkomen.

SE

1. Den maximala viktkapaciteten för överpanelen är 330 kg; överbelasta inte.
2. Låt inte barn klättra på möbler, då detta kan orsaka tippning och allvarliga skador.
3. För att säkerställa säkerheten, installera korrekt enligt instruktionerna och sök professionell hjälp om det behövs.
4. Placera inte möbler nära eldkällor eller heta föremål för att undvika brandrisk.
5. Placera inte möbler i fuktiga miljöer för att förhindra skador på materialen.
6. Kontrollera regelbundet alla kopplingar och fästelement för att säkerställa att de är säkra för att förhindra olyckor.
7. Denna produkt levereras med en anti-tippanordning; installera denna anordning för att förhindra skador vid tippning.

PL

1. Maksymalne obciążenie górnej płyty wynosi 330 kg; nie przeciążaj.
2. Nie pozwól dzieciom wspinać się na meble, ponieważ może to prowadzić do przewrócenia się i poważnych obrażeń.
3. Aby zapewnić bezpieczeństwo, zainstaluj prawidłowo zgodnie z instrukcją i w razie potrzeby skorzystaj z pomocy profesjonalistów.
4. Nie stawiaj mebli w pobliżu źródeł ognia lub gorących przedmiotów, aby uniknąć ryzyka pożaru.
5. Nie stawiaj mebli w wilgotnych środowiskach, aby zapobiec uszkodzeniu materiałów.
6. Regularnie sprawdzaj wszystkie złącza i elementy mocujące, aby upewnić się, że są stabilne i aby zapobiec wypadkom.
7. Produkt ten jest wyposażony w urządzenie zapobiegające przewróceniu; zainstaluj to urządzenie, aby uniknąć obrażeń w wyniku przewrócenia.

EN

Dear customer,

Thank you for purchasing this product. So that your appliance serves you well, please read all the instructions in this user's manual. If you have any questions, please contact our customer care center.

FR

Cher client,

Nous vous remercions d'avoir acheté ce produit. Afin que vous puissiez profiter pleinement de votre appareil, veuillez lire toutes les instructions de ce manuel d'utilisation. Si vous avez la moindre question, veuillez contacter notre centre d'assistance à la clientèle.

DE

Sehr geehrter Kunde,

Vielen Dank, dass Sie dieses Produkt erworben haben. Damit Ihr Gerät Ihnen gute Dienste leistet, lesen Sie bitte alle Hinweise in diesem Benutzerhandbuch. Wenn Sie Fragen haben, wenden Sie sich bitte an unser Kundendienstzentrum.

ES

Queridos clientes,

Gracias por comprar este producto. Para que su electrodoméstico le sirva mejor, lea todas las instrucciones de este manual del usuario. Si tiene alguna pregunta, comuníquese con nuestro Centro de Atención al Cliente.

IT

Caro Cliente,

Grazie per aver acquistato questo prodotto. Per servirti meglio con questo apparecchio ti prego di leggere tutte le istruzioni in presente manuale utente. In caso di dubbio, si prega di contattare il nostro centro assistenza clienti.

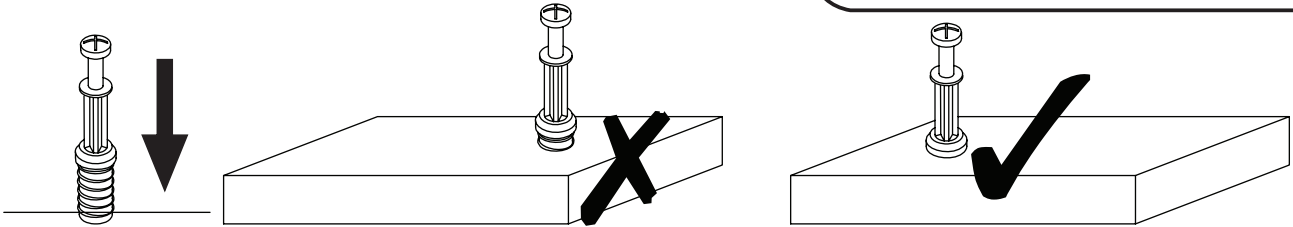

EN_QUICKFIT: Tighten quickfit until shoulder is flush with panel. Do not overtighten or undertighten.

FR_RACCORD RAPIDE: Faites serrer le raccord rapide jusqu'à ce que l'épaulement soit parfaitement encastré dans le panneau. Il ne faut ni trop serrer ni insuffisamment serrer.

ES_QUICKFIT: Apriete quickfit hasta que el hombro se descargue con el panel. NO lo sobreapriete ni lo apriete poco.

DE_QUICKFIT: Ziehen Sie den Quickfit fest, bis die Schulter mit der Platte bündig ist. Bitte nicht zu fest oder zu schwach anziehen.

IT_MONTAGGIO RAPIDO: Stringere il montaggio rapido fino a quando la spalla è a filo con il pannello, non stringere troppo o troppo poco.

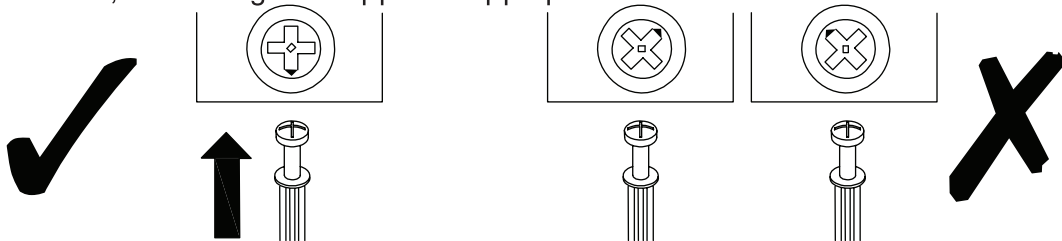

EN_CAM LOCK: When fitting cam lock, ensure starting position is correct before you insert connecting quickfit.

FR_SERRURE BATTEUSE: Avant d'insérer la serrure batteuse, veillez à la bonne orientation avant d'insérer le raccord rapide.

ES_CIERRE DE LA CÁMARA: Cuando instale el cierre de la cámara, asegúrese de que la posición de inicio es correcta antes de que inserte el quickfit conector.

DE_CAM-LOCK: Achten Sie bei der Montage des Cam-Locks auf die richtige Ausgangsposition, bevor Sie den Quickfit einsetzen.

IT_BLOCCAGGIO A CAMMA: Quando si monta il bloccaggio a camma, assicurarsi che la posizione iniziale sia corretta prima di inserire il montaggio rapido di collegamento.

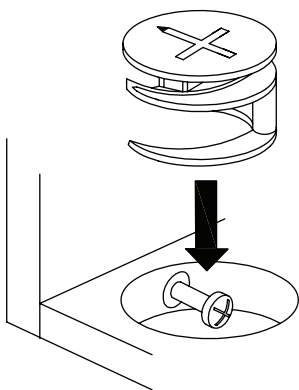

EN_Quickfit head should be in the centre of the cam lock when the two panels are joined.

Cam lock should be inserted before quickfit.

FR_Lorsque les deux panneaux sont assemblés, la tête du raccord rapide doit reposer au centre de la serrure batteuse. Il faut insérer la serrure batteuse avant le raccord rapide.

ES_El cabezal del quickfit debe estar en el centro del cierre de la cámara cuando se unan los dos paneles.

Se debe insertar el cierre de la cámara antes que el quickfit.

DE_Der Quickfit-Kopf sollte sich in der Mitte des Cam-Locks befinden, wenn die beiden Platten zusammengefügt sind.

Der Cam-Lock sollte vor dem Quickfit eingesetzt werden.

IT_La testa del montaggio rapido deve trovarsi al centro del bloccaggio a camma quando i due pannelli sono uniti.

Il Bloccaggio a Camma deve essere inserito prima del montaggio rapido.

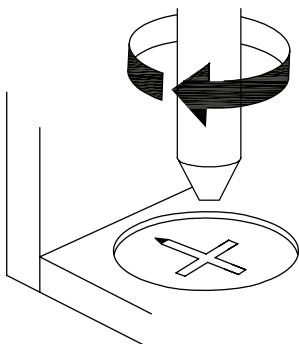

EN_Turn cam lock clockwise to tighten.

FR_Faites tourner la serrure batteuse dans le sens des aiguilles d'une montre pour la resserrer.

ES_Gire el cierre de la cámara en sentido horario para apretarlo.

DE_Drehen Sie den Cam-Lock im Uhrzeigersinn, um ihn festzuziehen.

IT_Ruotare il bloccaggio a camma in senso orario per stringere.

EN It may be necessary to adjust the hinges so that the doors align. Use the instructions below as a guide.

FR Il est parfois nécessaire d'ajuster les charnières pour un meilleur alignement des portes. Servez-vous des instructions ci-dessous comme guide.

ES Puede que sea necesario ajustar los quicios de forma que se alineen las puertas. Use las instrucciones que aparecen debajo como guía.

DE Möglicherweise müssen Sie die Scharniere so einstellen, dass die Türen ausgerichtet sind. Verwenden Sie die nachstehenden Anweisungen als Leitfaden.

IT Potrebbe essere necessario regolare le cerniere in modo che le porte siano allineate. Per fare ciò attenersi alle istruzioni sottostanti.

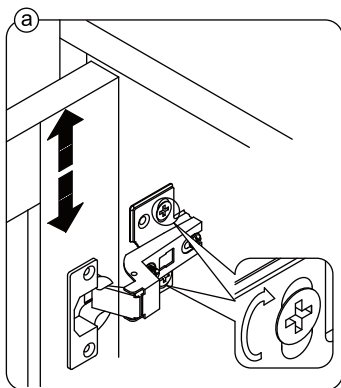

EN To adjust the door vertically loosen the screw as shown and move up and down as needed.

FR Si vous souhaitez régler la porte **verticalement**, desserrez la vis comme indiqué et déplacez la porte de haut en bas selon les besoins.

ES Para ajustar la puerta **verticalmente** afloje el tornillo tal y como se muestra y muévelo hacia arriba o hacia abajo según sea necesario.

DE Um die Tür **vertikal** auszurichten, lösen Sie die Schraube wie abgebildet und bewegen Sie sie nach Bedarf nach oben oder nach unten.

IT Per allineare la porta **verticalmente** allentare la vite come mostrato e spostarla in alto o in basso secondo necessità.

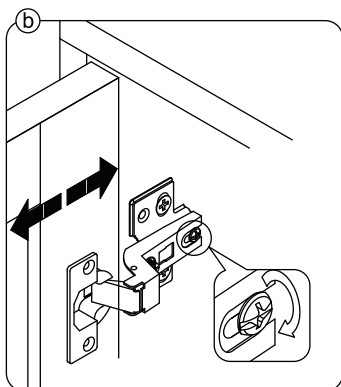

EN To adjust the gap from the door to the main frame turn the screw clockwise or anti-clockwise as needed.

FR Si vous souhaitez ajuster l'**écart** entre la porte et le cadre principal, tournez la vis dans le sens des aiguilles d'une montre ou dans le sens inverse, si nécessaire.

ES Para ajustar el **espacio** desde la puerta al marco principal, gire el tornillo en sentido horario o antihorario, según se necesite.

DE Um den **Abstand** von der Tür zum Hauptrahmen auszurichten, drehen Sie die Schraube je nach Bedarf im oder gegen den Uhrzeigersinn.

IT Per regolare lo **spazio** tra la porta e il telaio principale, avvitare o svitare la vite secondo necessità.

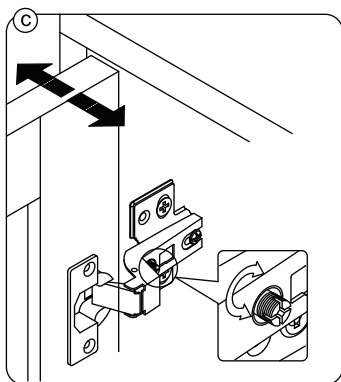

EN To adjust the door laterally adjust the screw as shown by turning clockwise or anti-clockwise.

FR Si vous souhaitez ajuster la porte **latéralement**, ajustez la vis comme indiqué en tournant dans le sens des aiguilles d'une montre ou dans le sens inverse des aiguilles d'une montre.

ES Para ajustar la puerta **lateralmente** ajuste el tornillo tal y como se muestra girándolo en sentido horario y antihorario.

DE Um die Tür **seitlich** auszurichten, stellen Sie bitte die Schraube wie abgebildet durch Drehen im oder gegen den Uhrzeigersinn ein.

IT Per allineare la porta **lateralmente** regolare la vite come mostrato, avvitandola o svitandola.

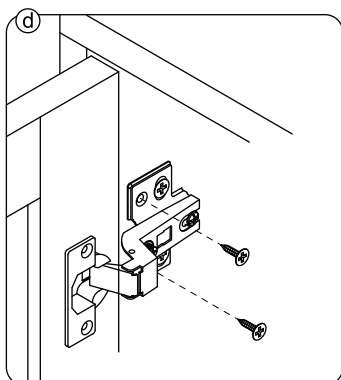









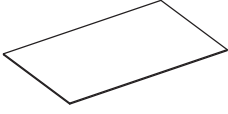
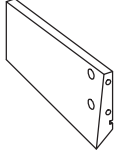
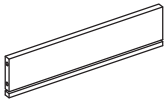
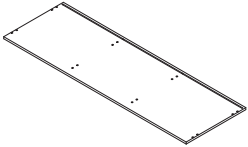
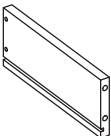
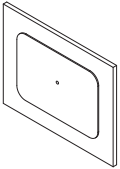

EN Please fix other screws

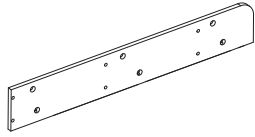
FR Merci de serrer les autres vis.

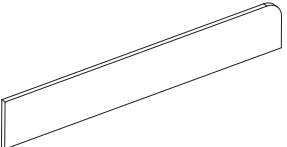
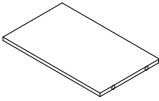
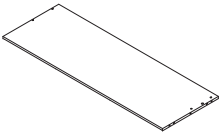
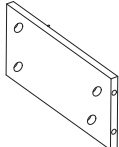
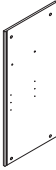
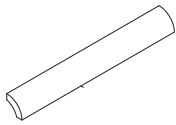
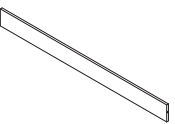
ES Fije los demás tornillos

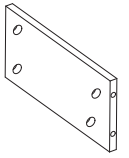
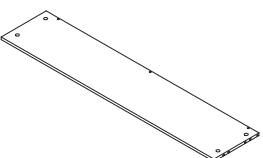
DE Befestigen Sie bitte die anderen Schrauben

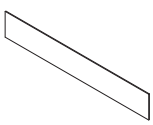
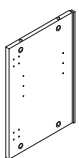
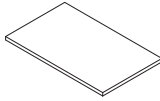
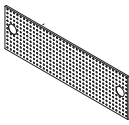
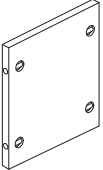
IT Fissare le altre viti

NO.	N651P366138	QTY	NO.	N651P366139	QTY	NO.	N651P366140	QTY
4		3	2		3	1		3
6		1	3		3	5		3
12		2	18		2	7		1
13		1	19		2	8		2
14		1	20		4	9		1
15		2	22		1	10		1
20		1	23		1	11		1
29		1	25		1	16		2
33		1	27		1	17		1

PARTS

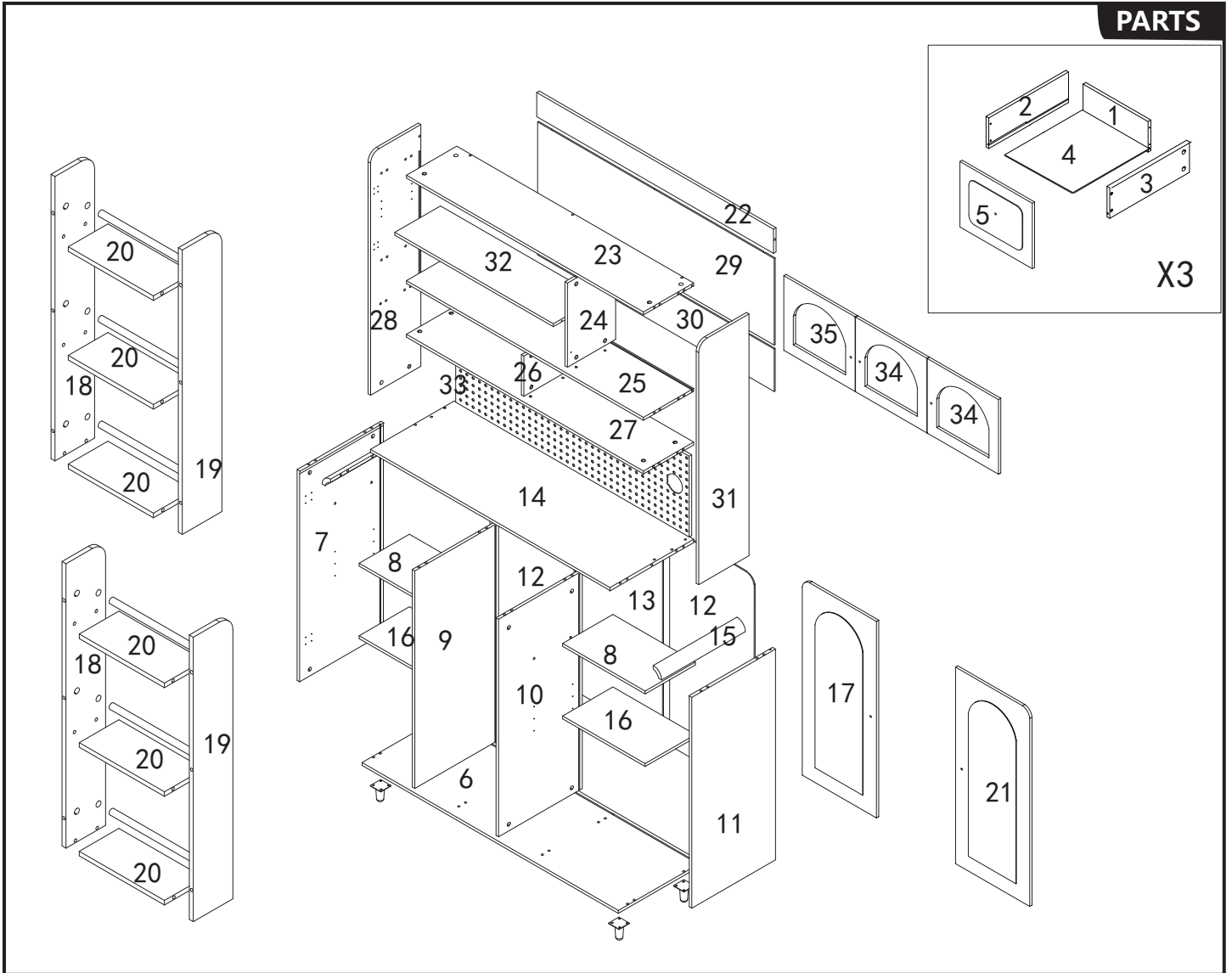

HARDWARE

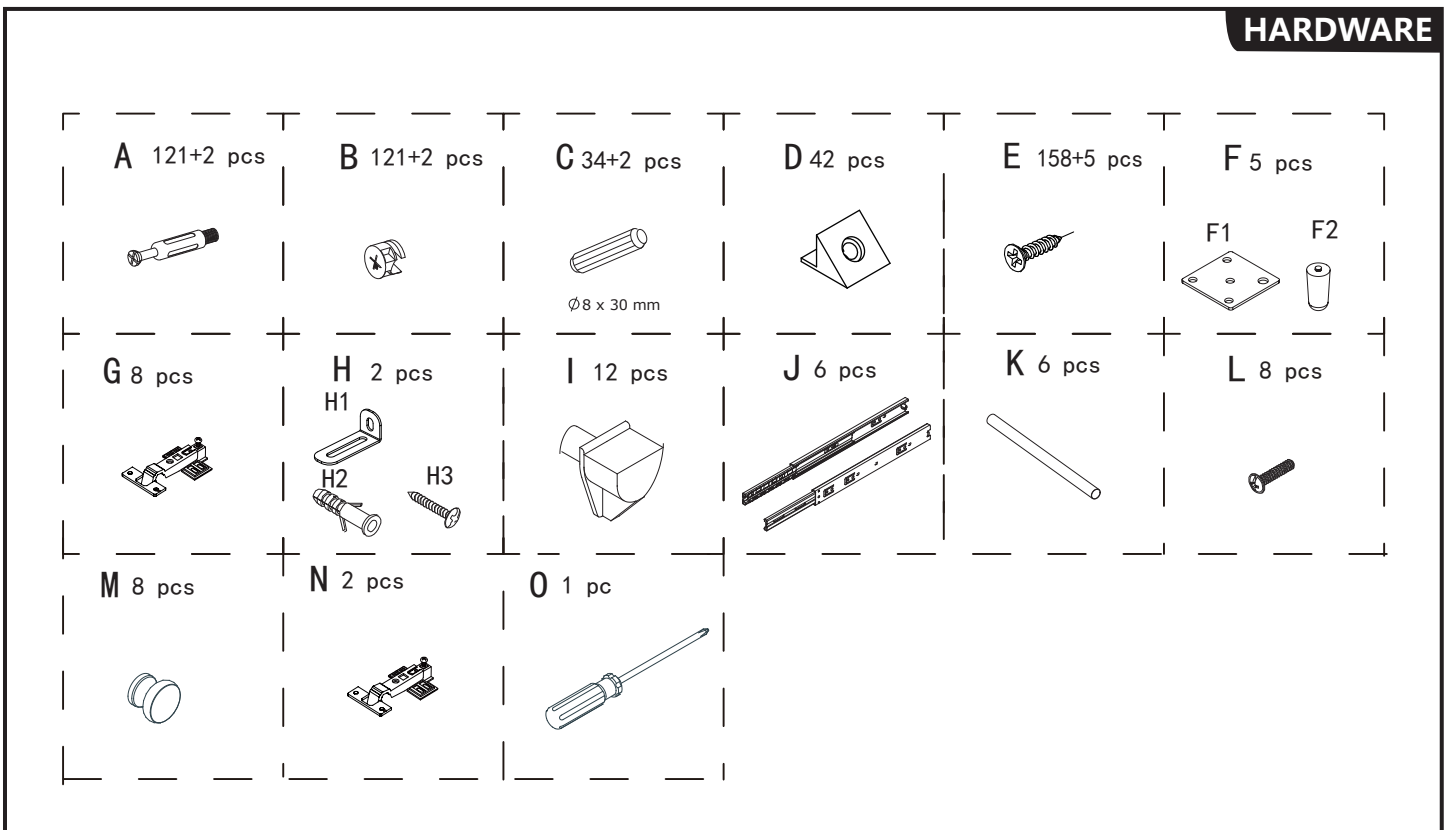

DE

Vor dem Einbau die Schrauben in die Löcher stecken und festziehen, aber nicht bis 100%, 70% bis 80% anziehen reicht aus. Schließlich, nachdem alle Schrauben installiert sind, ziehen Sie alle Schrauben auf 100%. Wenn Sie auf diese Probleme stoßen, wie z. B. Fehlausrichtung der Löcher oder Unfähigkeit, bestimmte Teile zu installieren, überprüfen Sie bitte, ob die Schrauben korrekt verwendet werden und passen Sie die Dichtigkeit der Schrauben an.

UK

Before installation, insert the screws into the holes and tighten them, but do not tighten them to 100%, 70% to 80% is sufficient. Finally, after all screws are installed, tighten all screws to 100%. If you encounter these issues, such as if the holes cannot be aligned or some parts cannot be installed, please check if the screws are used correctly and adjust the tightness of the screws.

FR

Insérer la vis dans le trou avant la fin de l'assemblage, serrer la vis, mais ne pas serrer à 100%, 70% ~ 80% est correct. Enfin, une fois que toutes les vis sont bien serrées, toutes les vis sont serrées à 100%. Si vous rencontrez ces problèmes, par exemple si les trous ne sont pas alignés ou si certaines pièces ne peuvent pas être montées, vérifiez que les vis sont utilisées correctement et Ajustez leur serrage.

1.

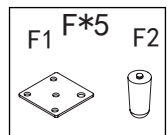
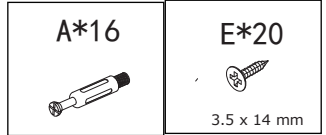
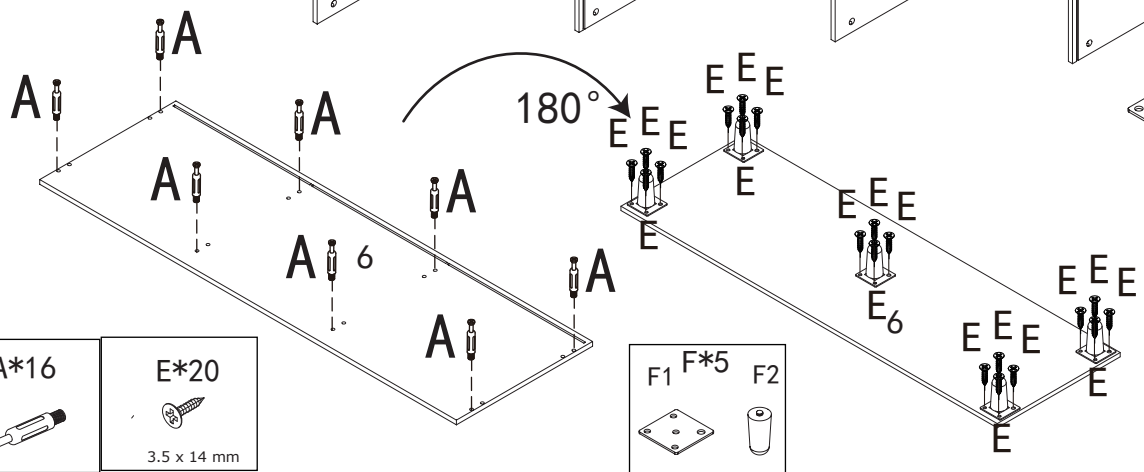
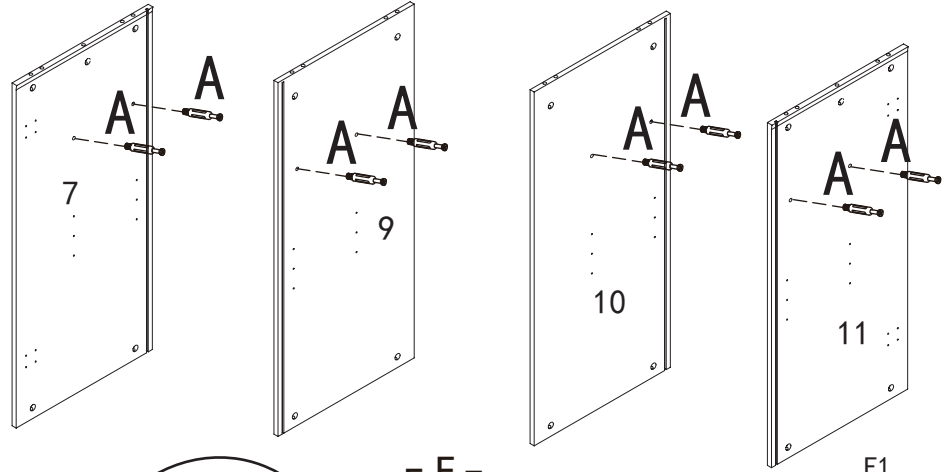
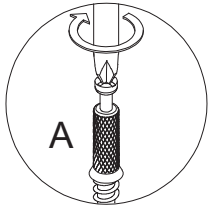

x 5

2.

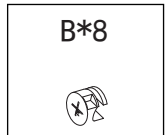
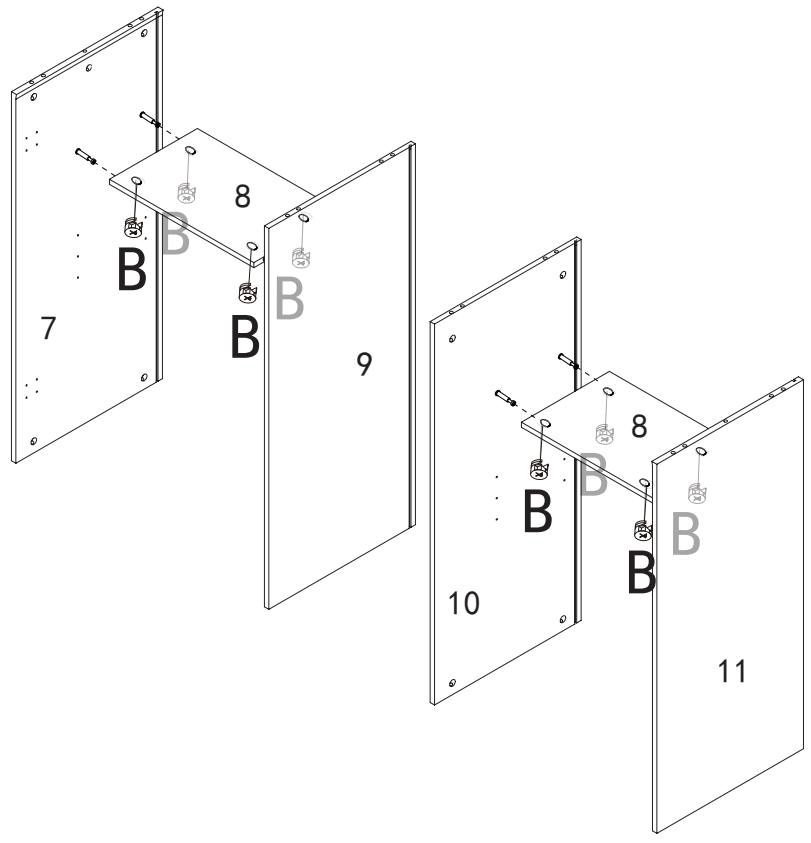

3.

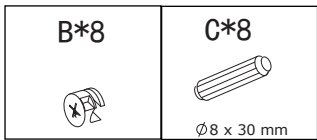
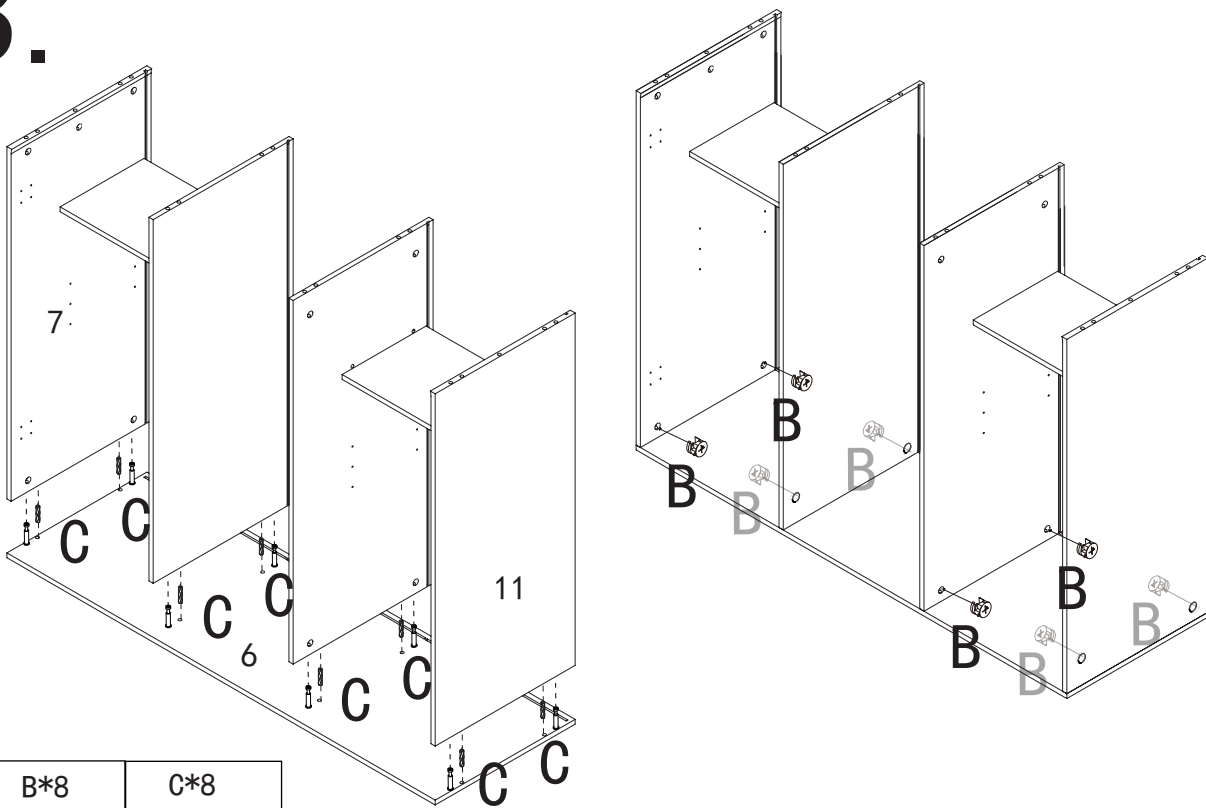

4.

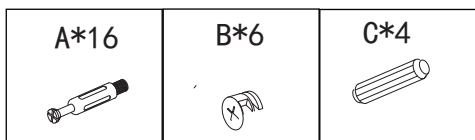
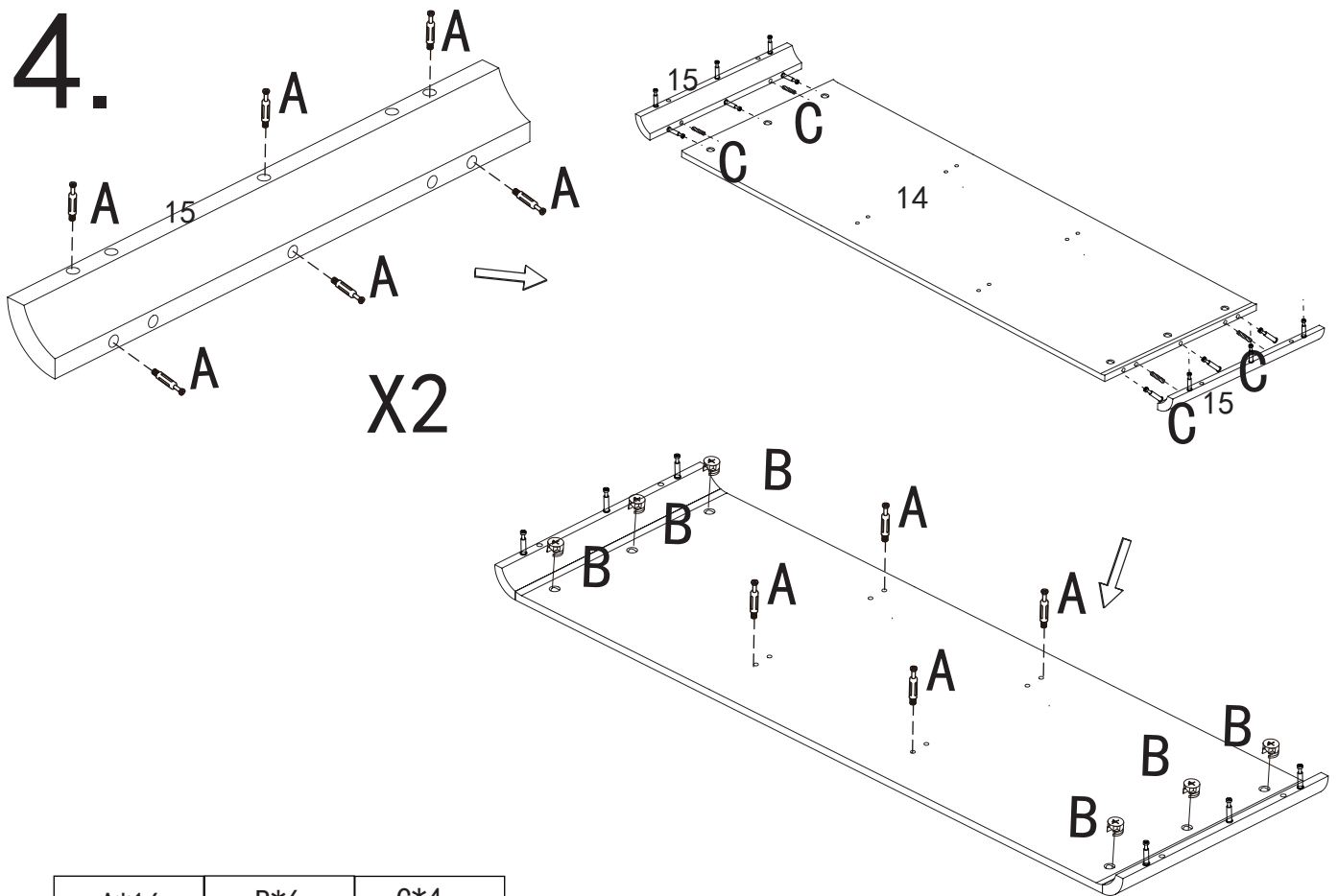

5.

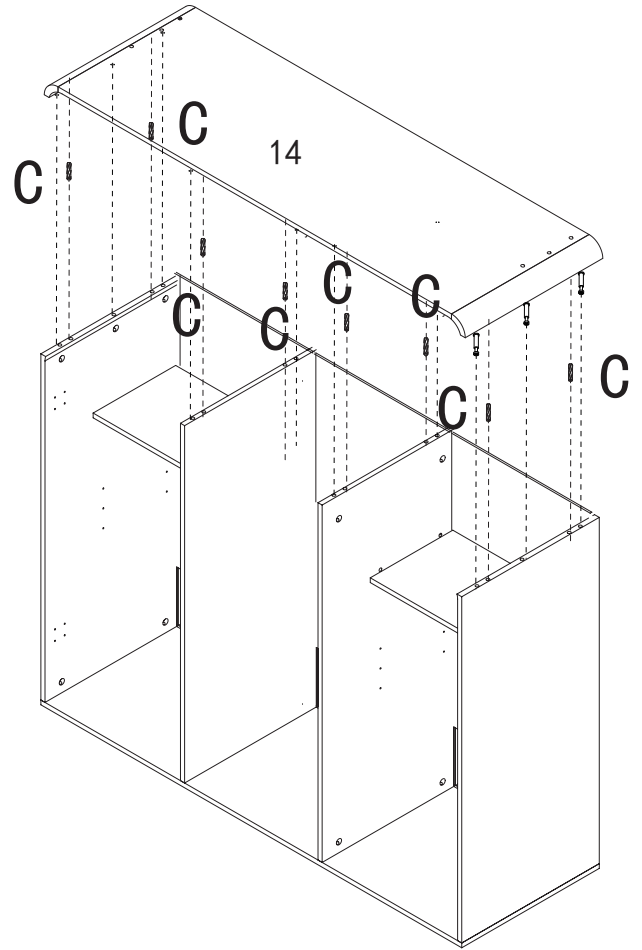
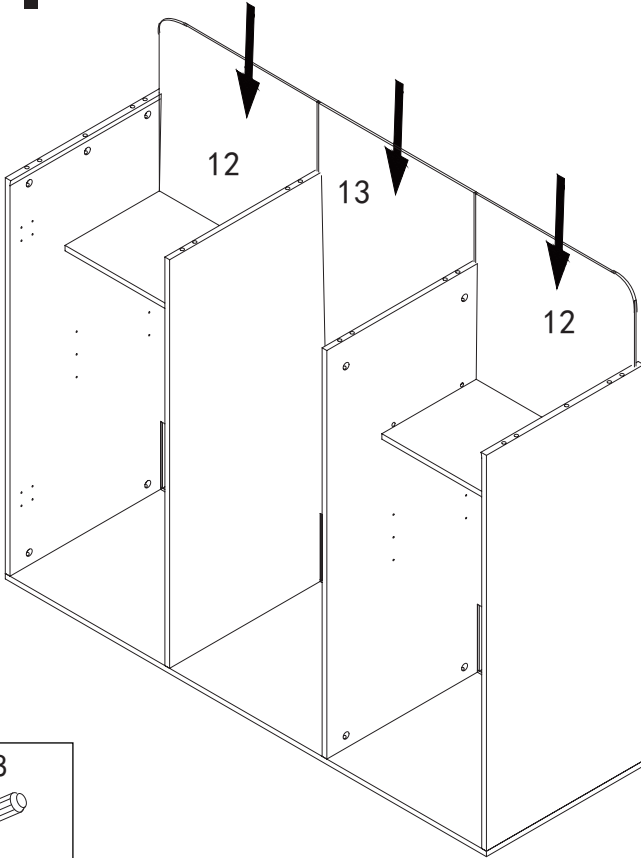

C*8



Ø8 x 30 mm

6.

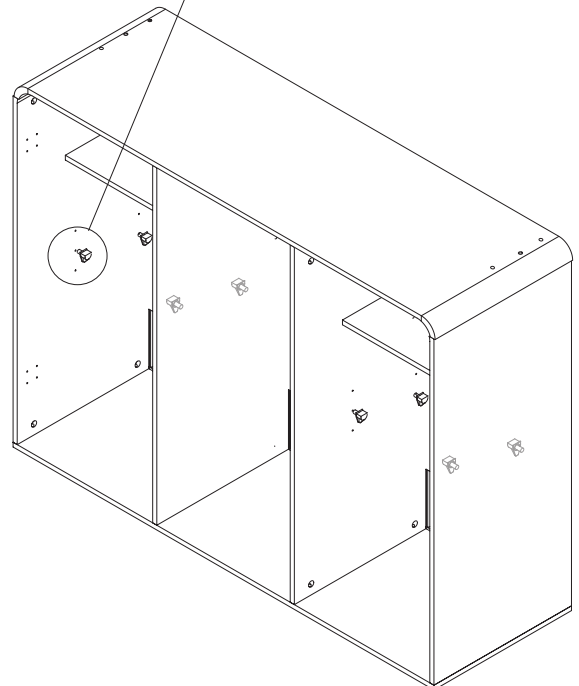
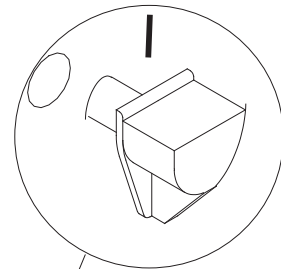
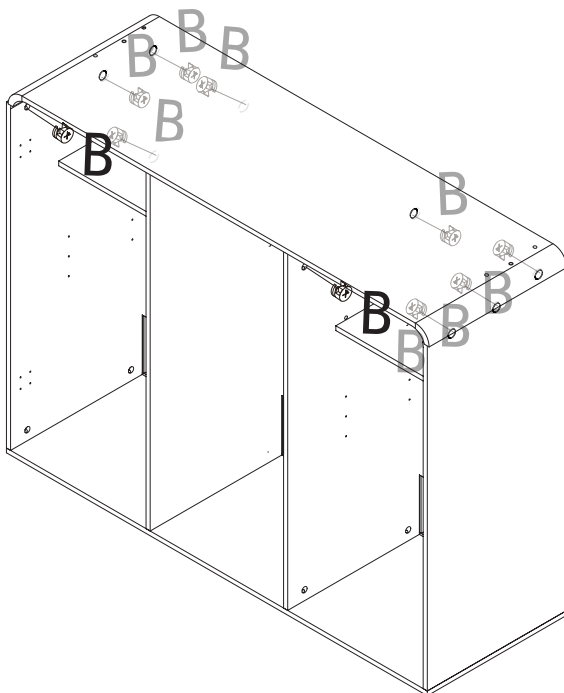





B*10

I*8

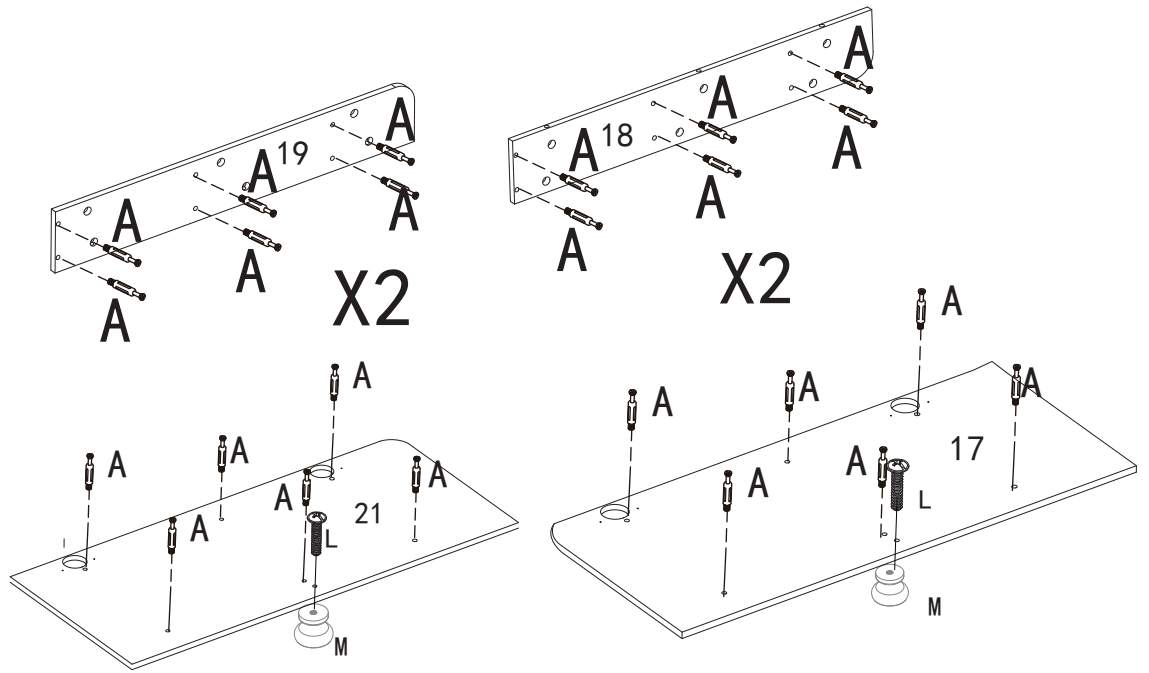



7.

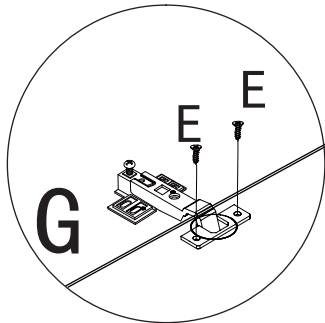
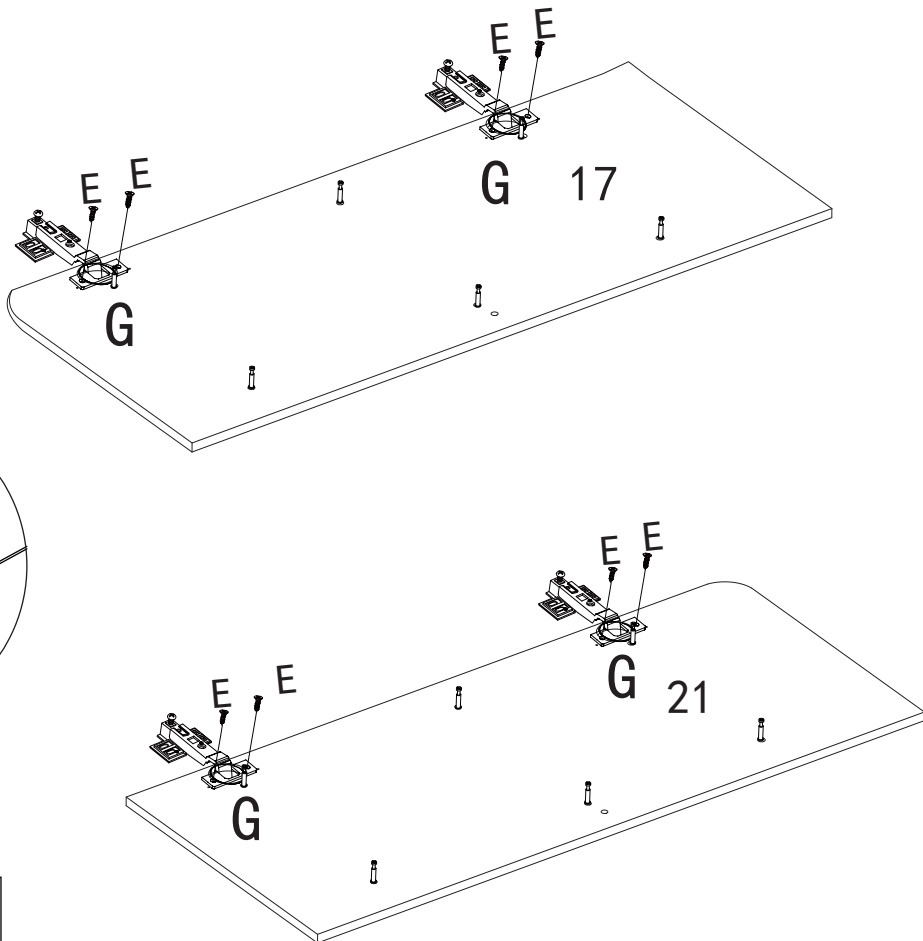

A*36 	M*2 	L*2 
--	---	---

8.

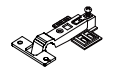

E*8  Ø3.5 x 14 mm	G*4 
--	--

9.

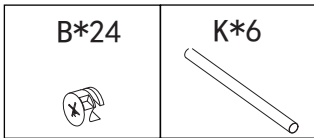
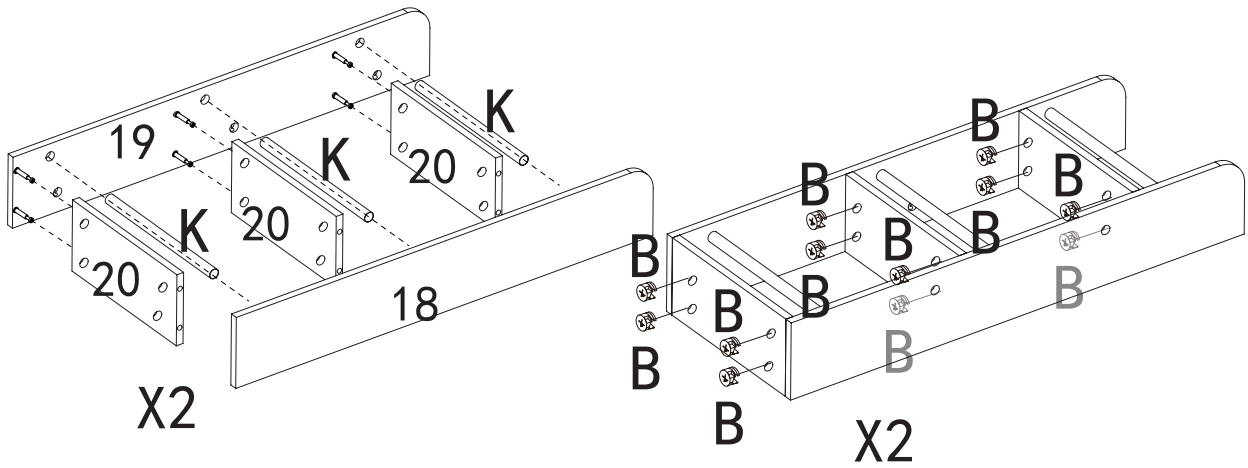

10.

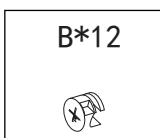
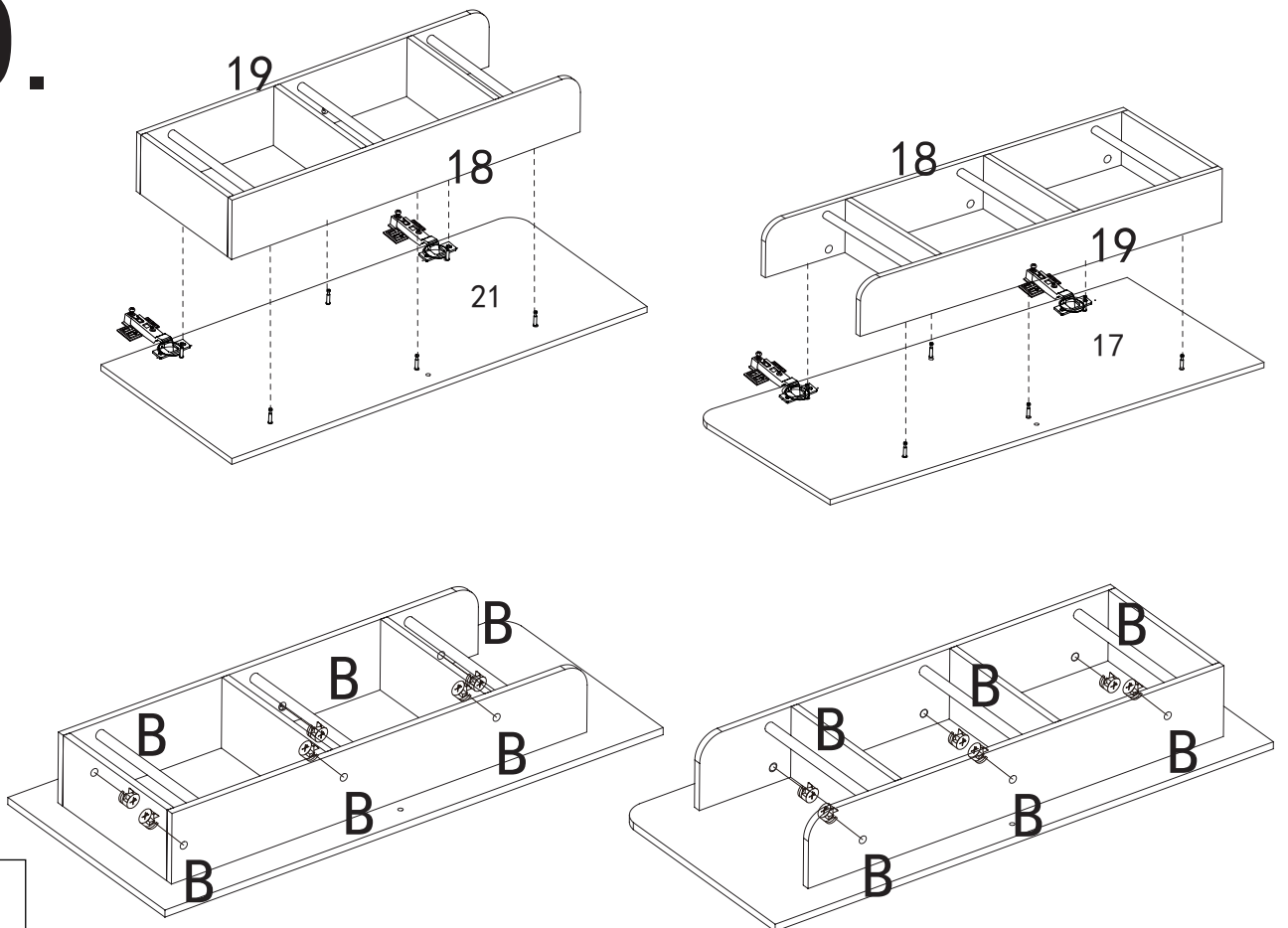

11.

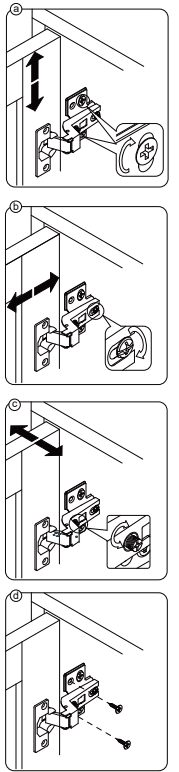
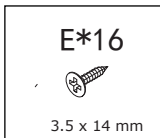
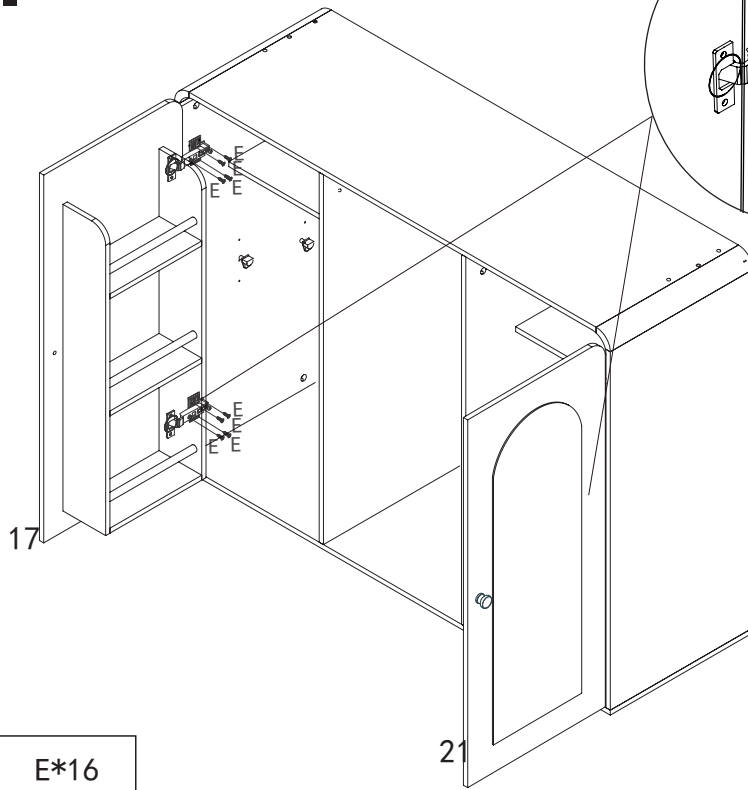



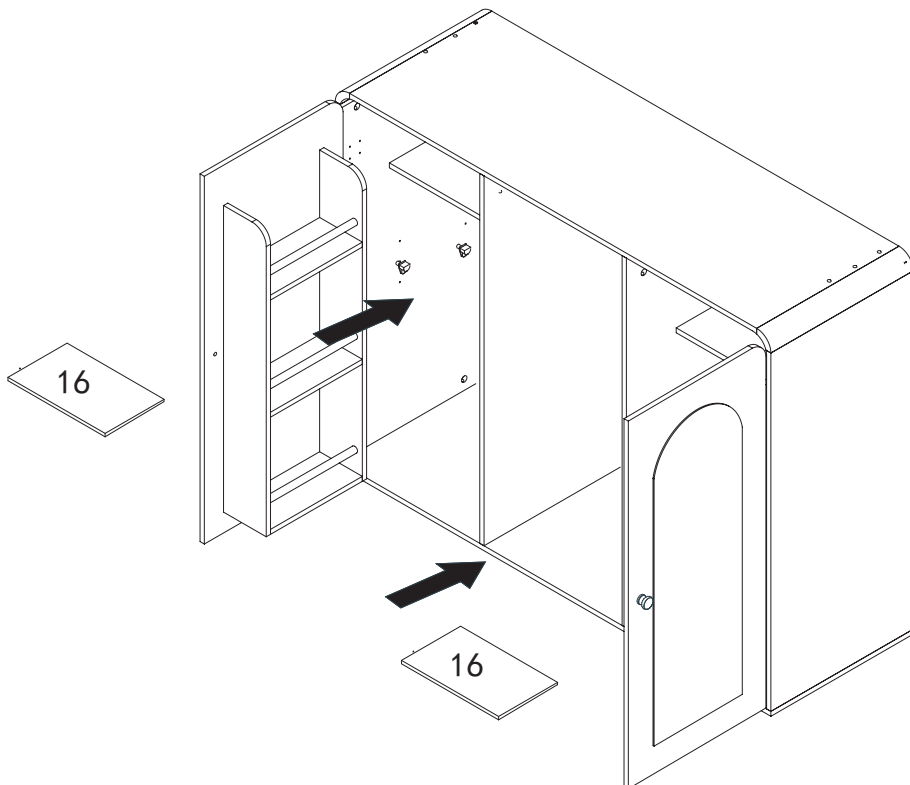

12.

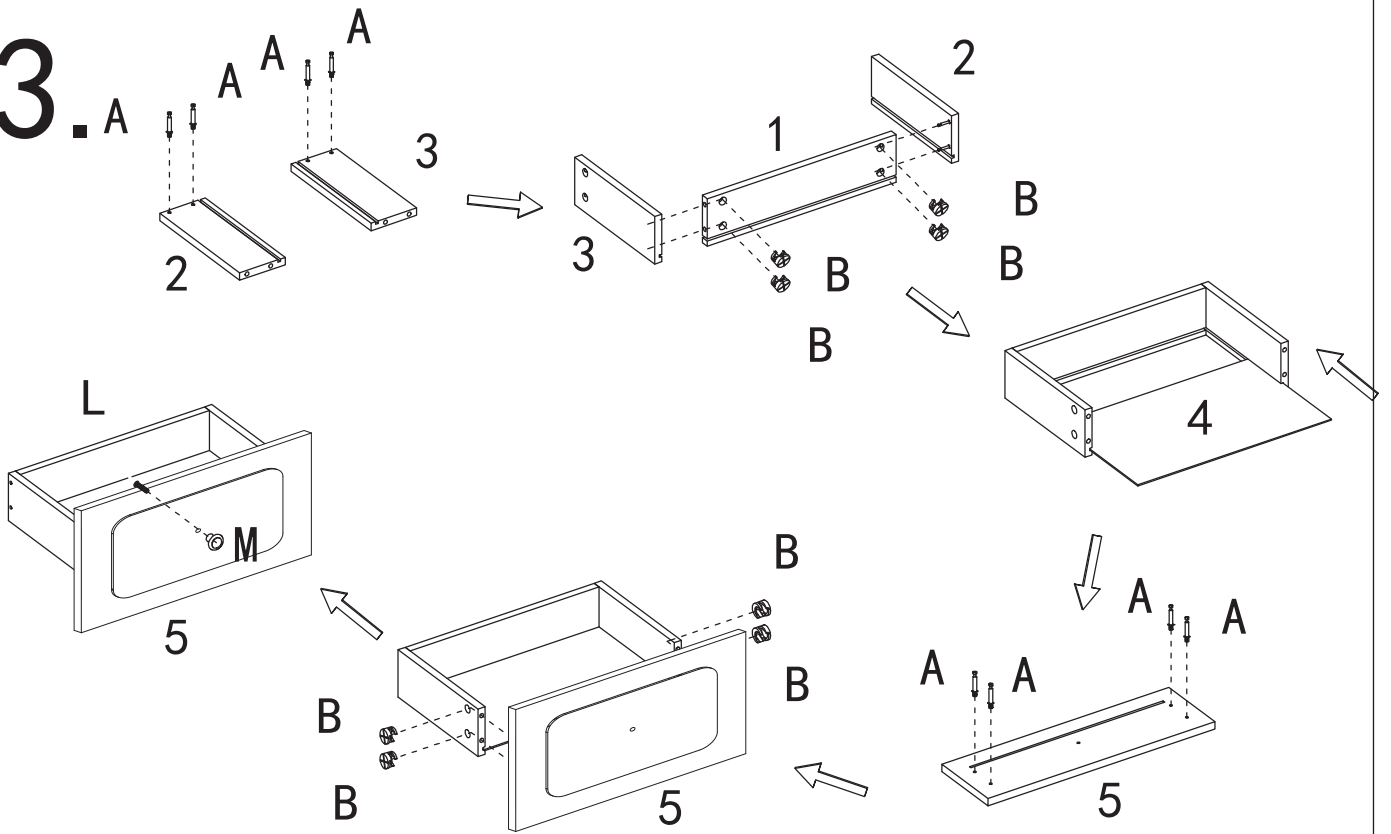

13.





A*24 	B*24 	L*3 	M*3 
--	---	--	--

X3

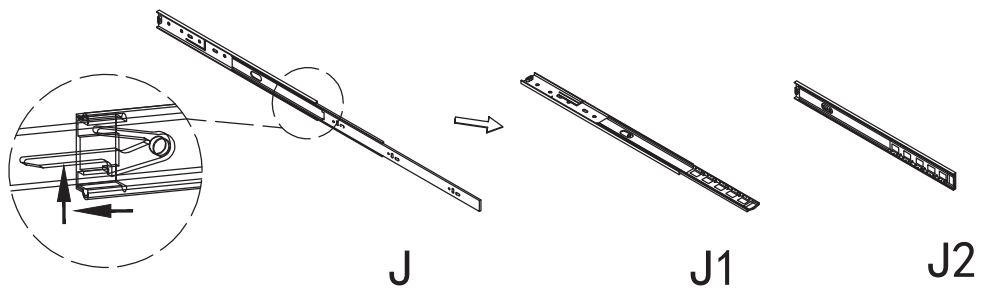
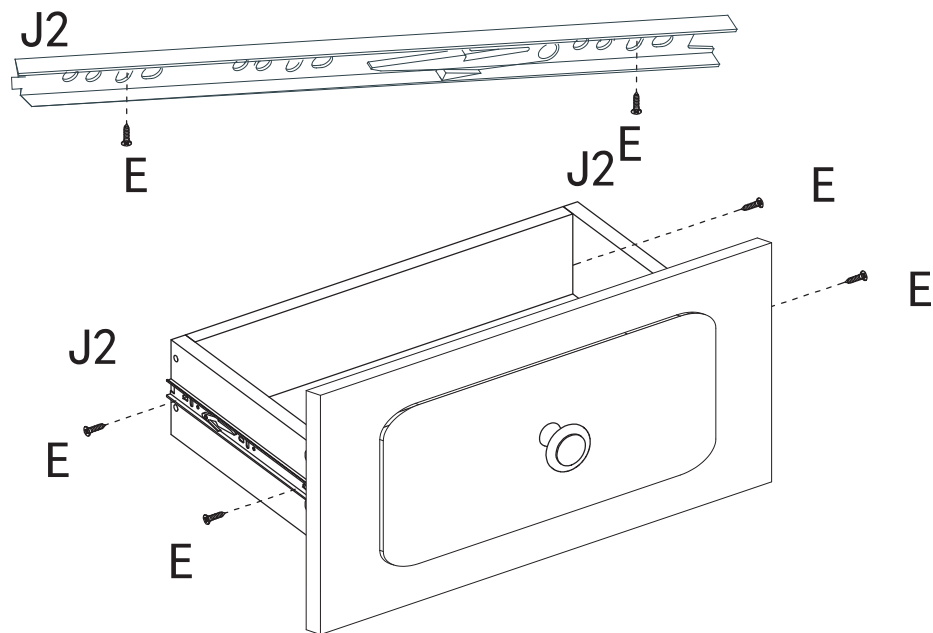
14.



E*12  3.5 x 14 mm	J*3 
--	--

X3

15.

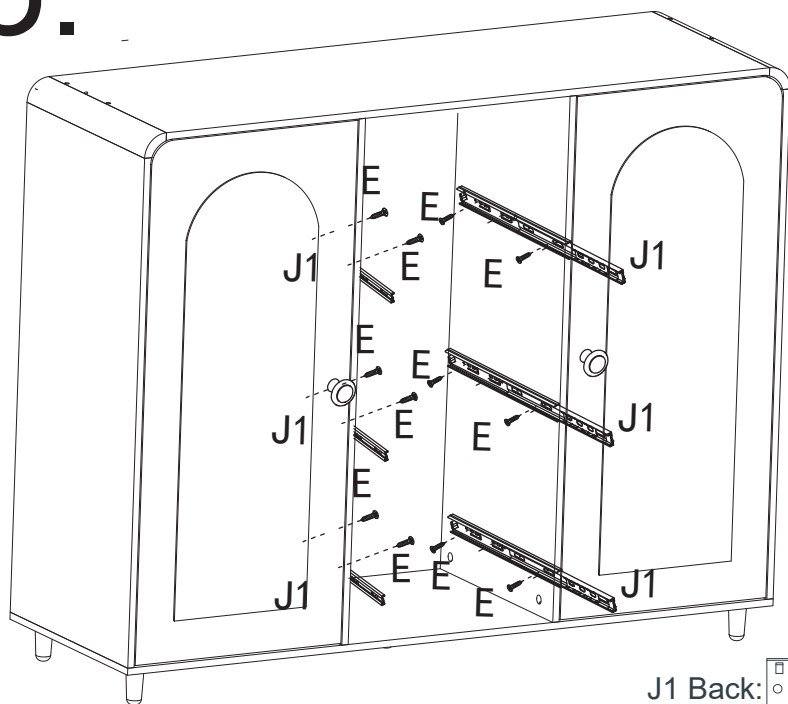

UK:
Please locate the holes from the back of part J1.

FR:
Veuillez localiser les trous à l'arrière de la pièce J1.

DE:
Suchen Sie die Löcher auf der Rückseite von Teil J1.

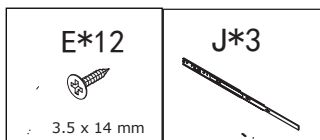

16.

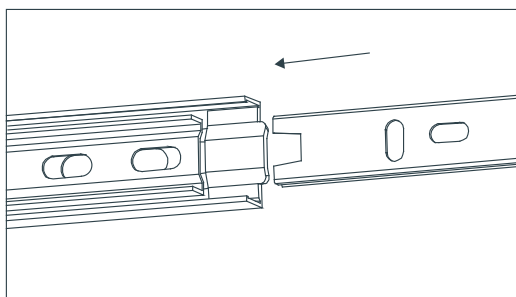

UK:
Align the slide runners on the drawer with the unit and push it carefully inside until it stops.
If the drawer does not go in smoothly please take it out and repeat the step.

FR:
Alignez les glissières du tiroir avec l'unité et poussez-la délicatement à l'intérieur jusqu'à la butée.
Si le tiroir ne s'insère pas facilement, retirez-le et répétez

DE:
Richten Sie die Schienen der Schublade am Möbel aus und schieben Sie sie vorsichtig bis zum Anschlag hinein. Sollte die Schublade nicht reibungslos einfahren, nehmen Sie sie bitte heraus und wiederholen Sie den Schritt.

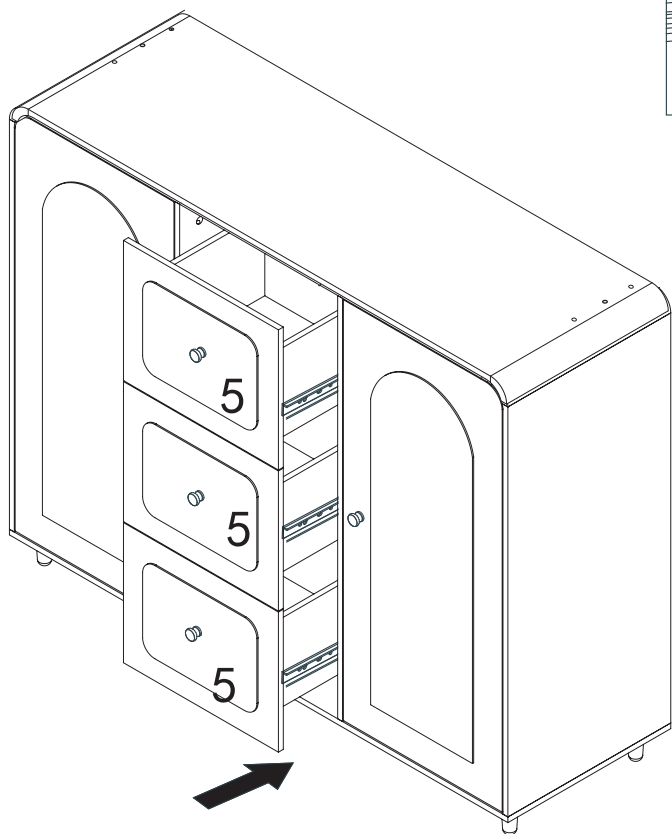

17.

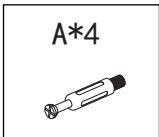
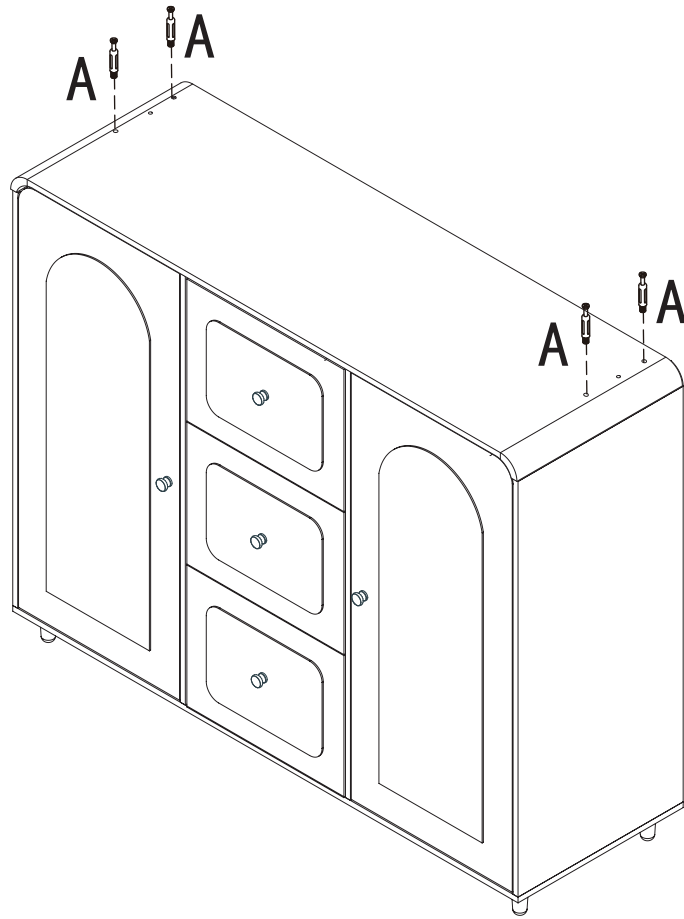

18.

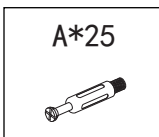
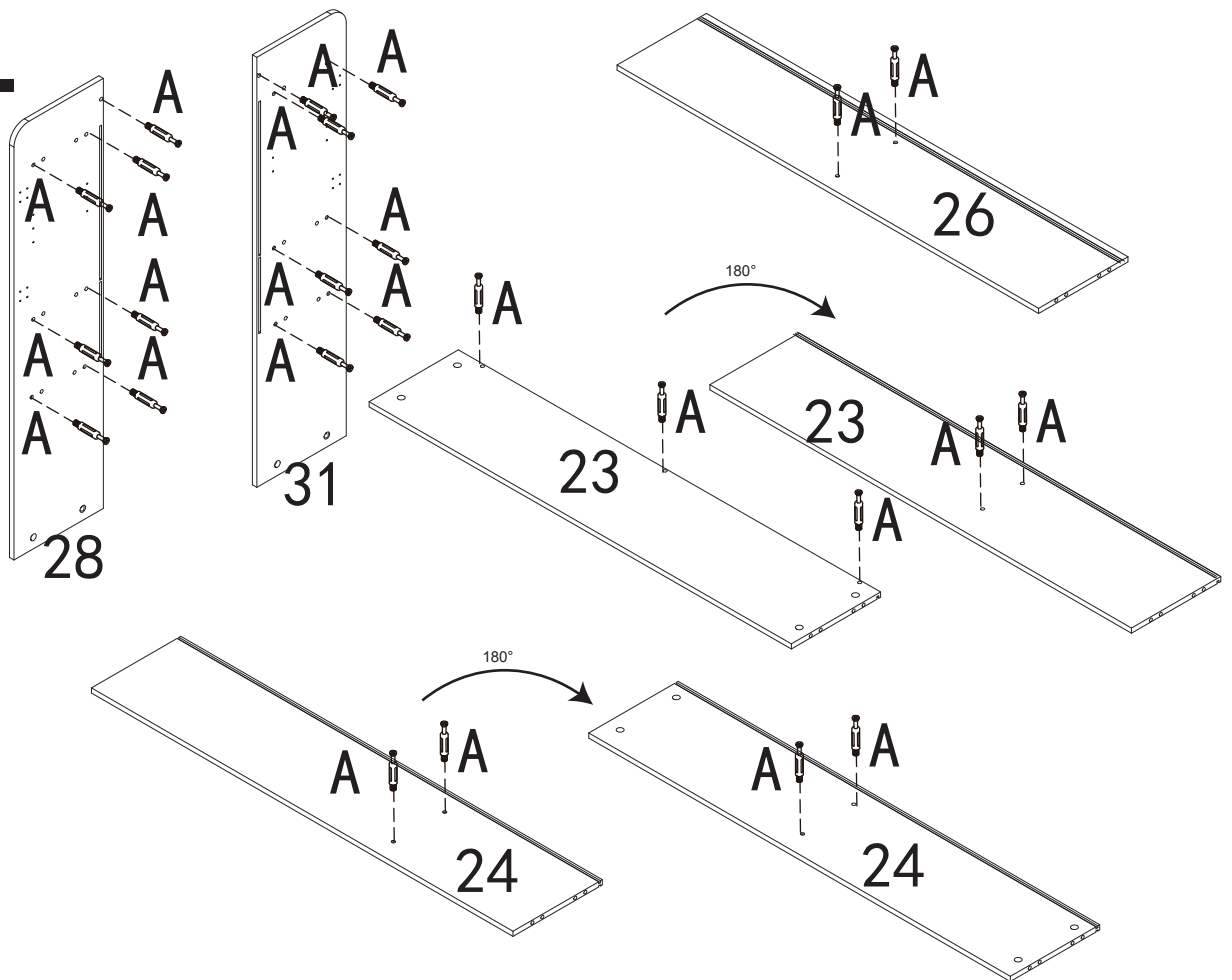

19.

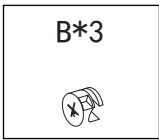
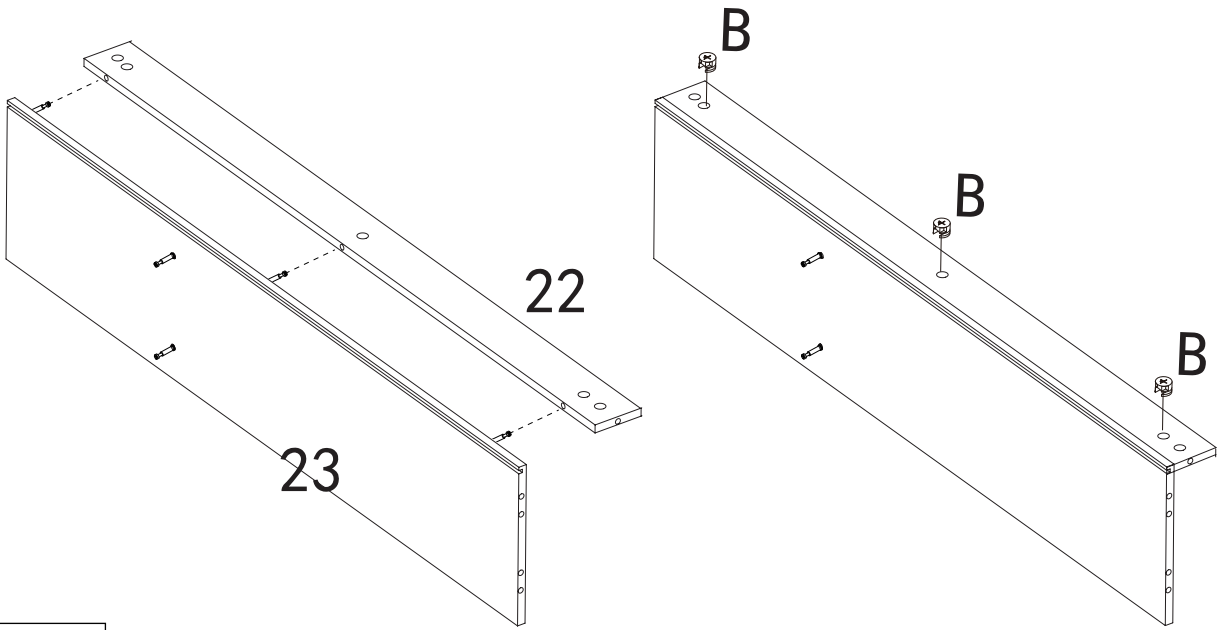

20.

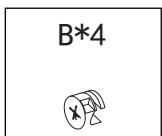
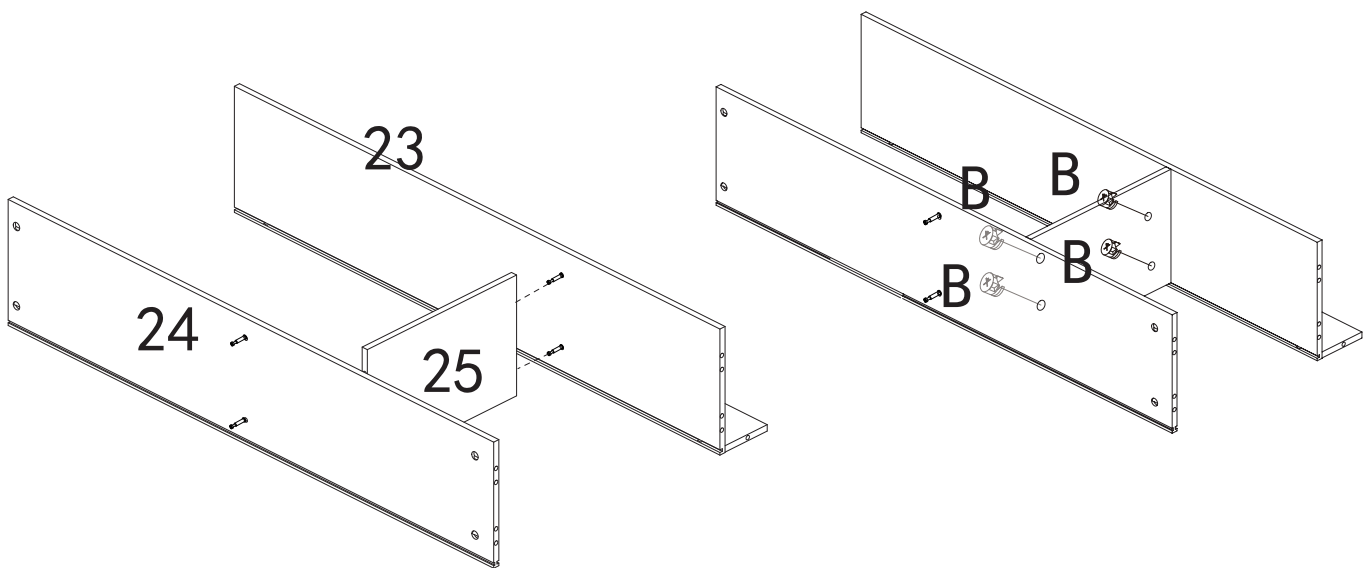

21.

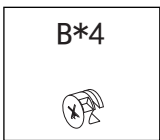
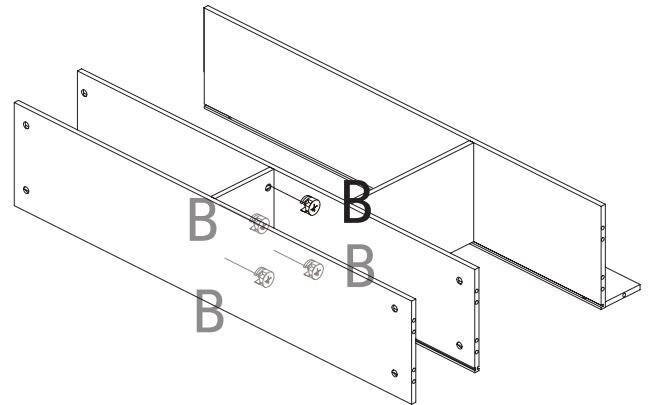
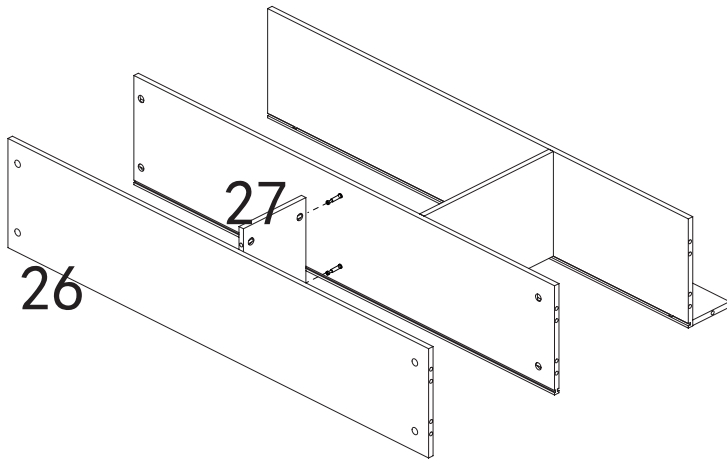

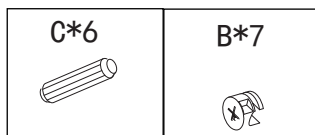
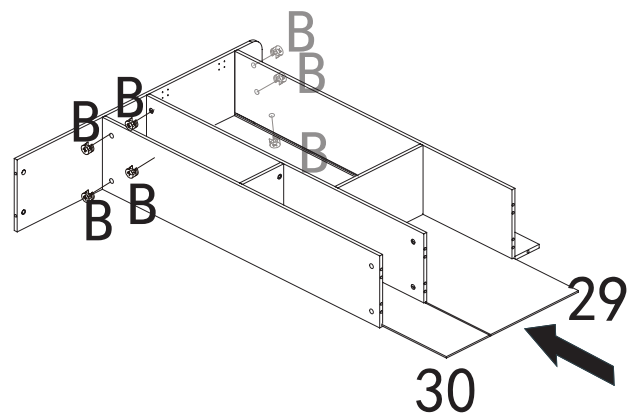
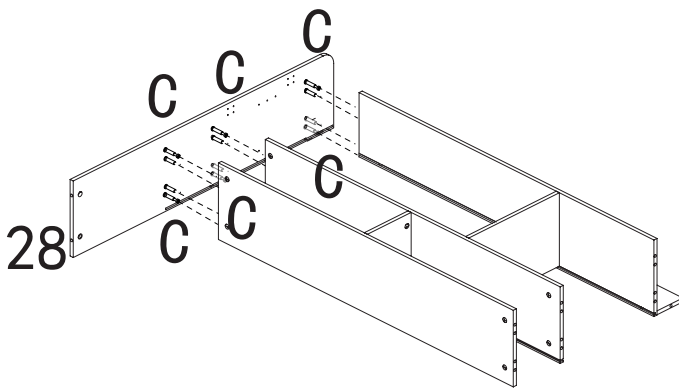

22.

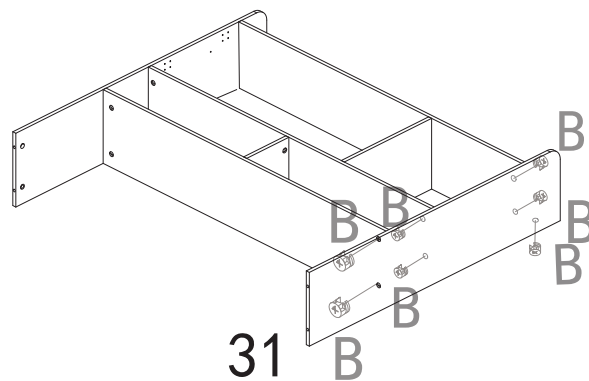
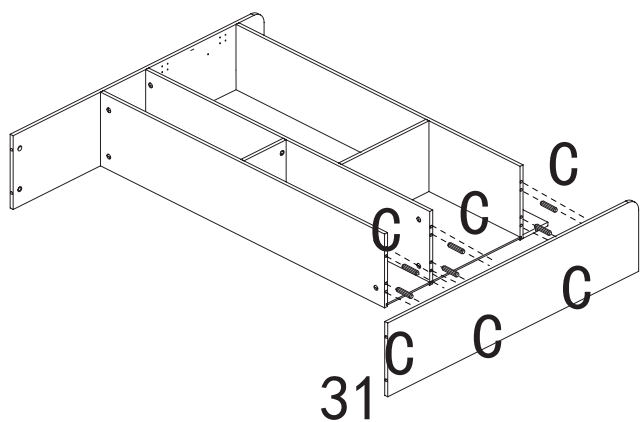

23.



B*7	C*6
	



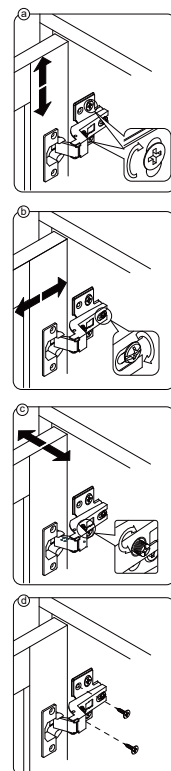
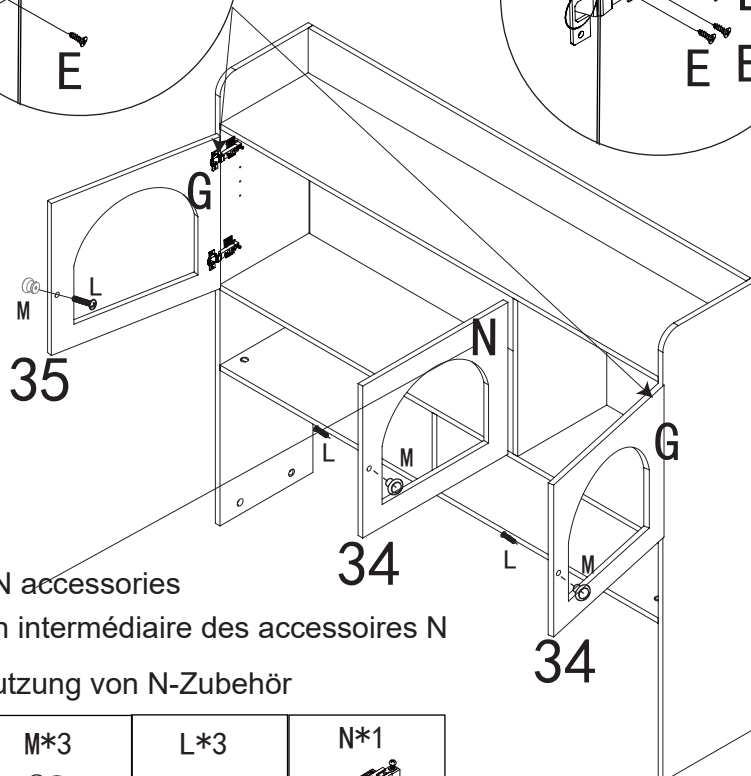
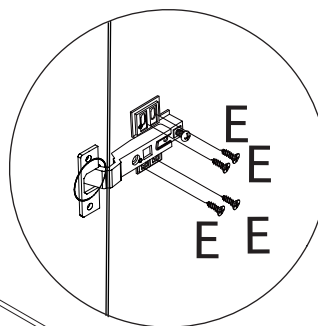
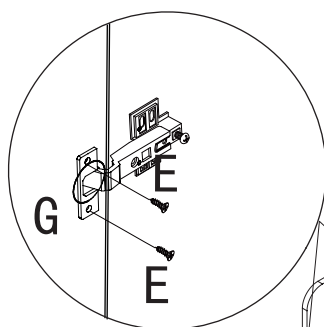

24.



UK:Note: Interim use of N accessories

FR:Remarque : utilisation intermédiaire des accessoires N

DE:Hinweis: Zwischennutzung von N-Zubehör

G*2	E*36	M*3	L*3	N*1
	 3.5 x 14 mm			

25.

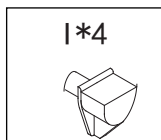
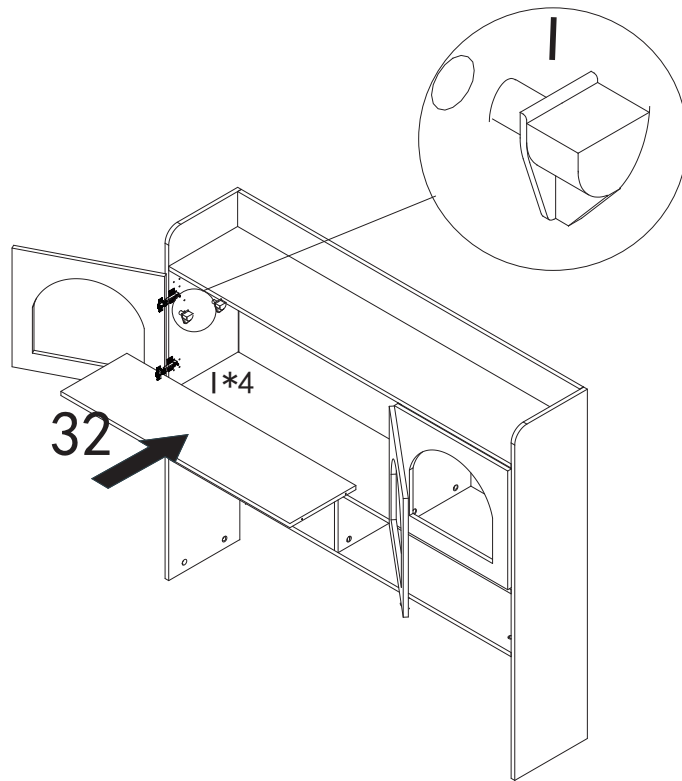

26.

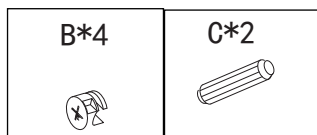
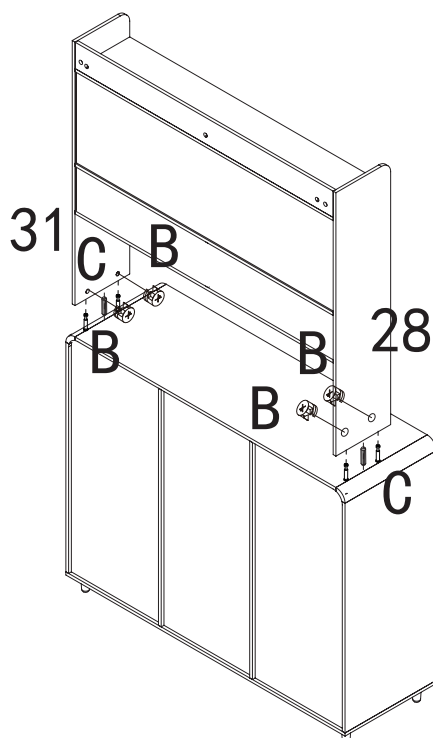

27.

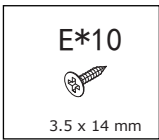
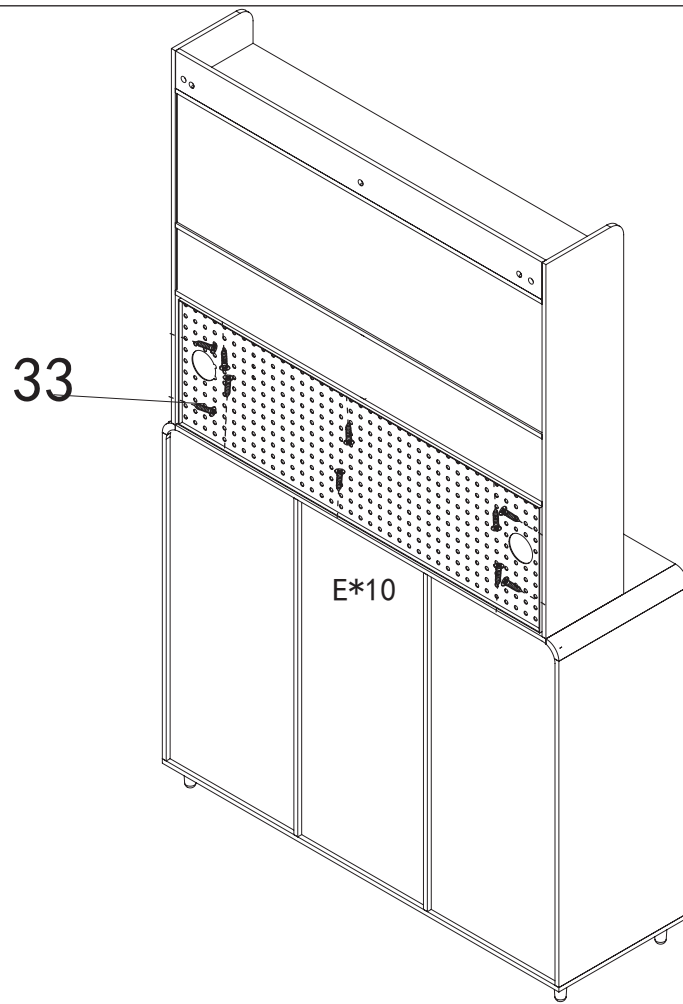

28.

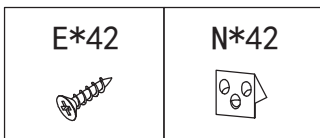
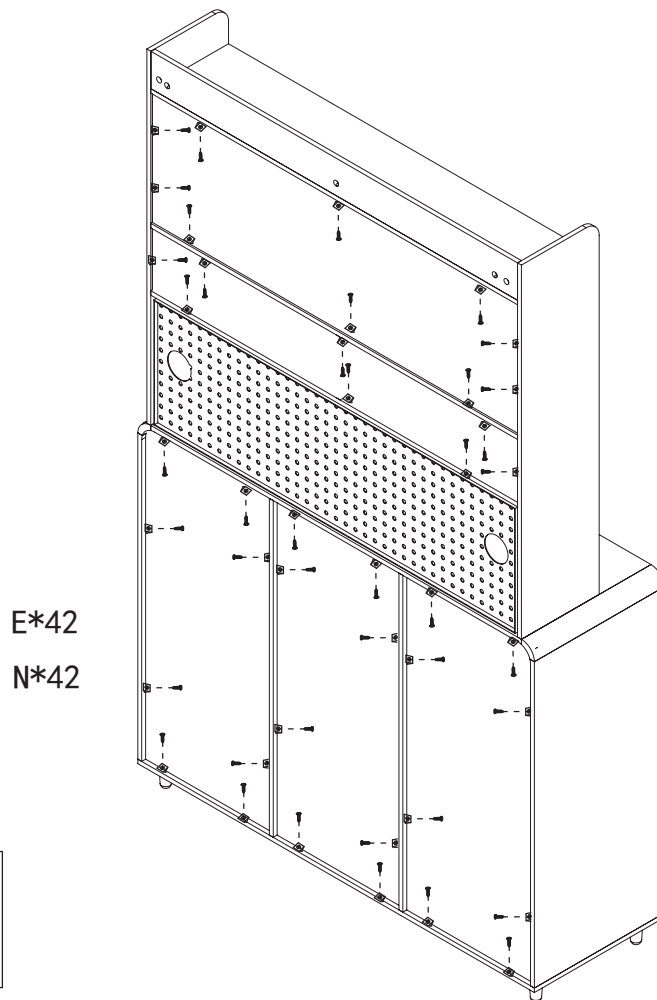

29.

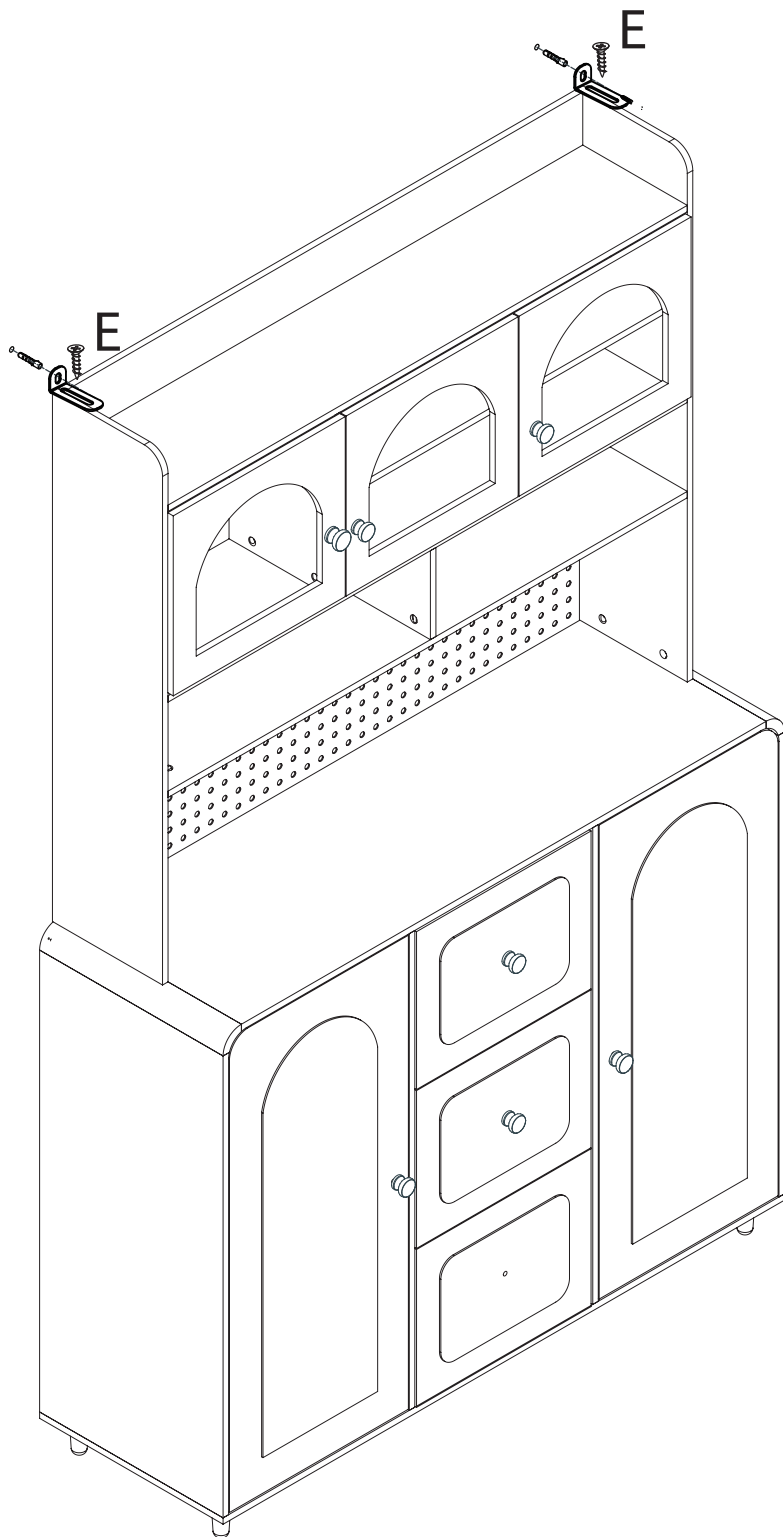

WALL

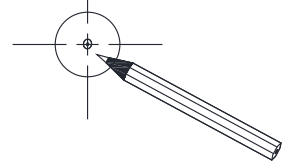

WALL

drilling hole
6x30mm



WALL

