

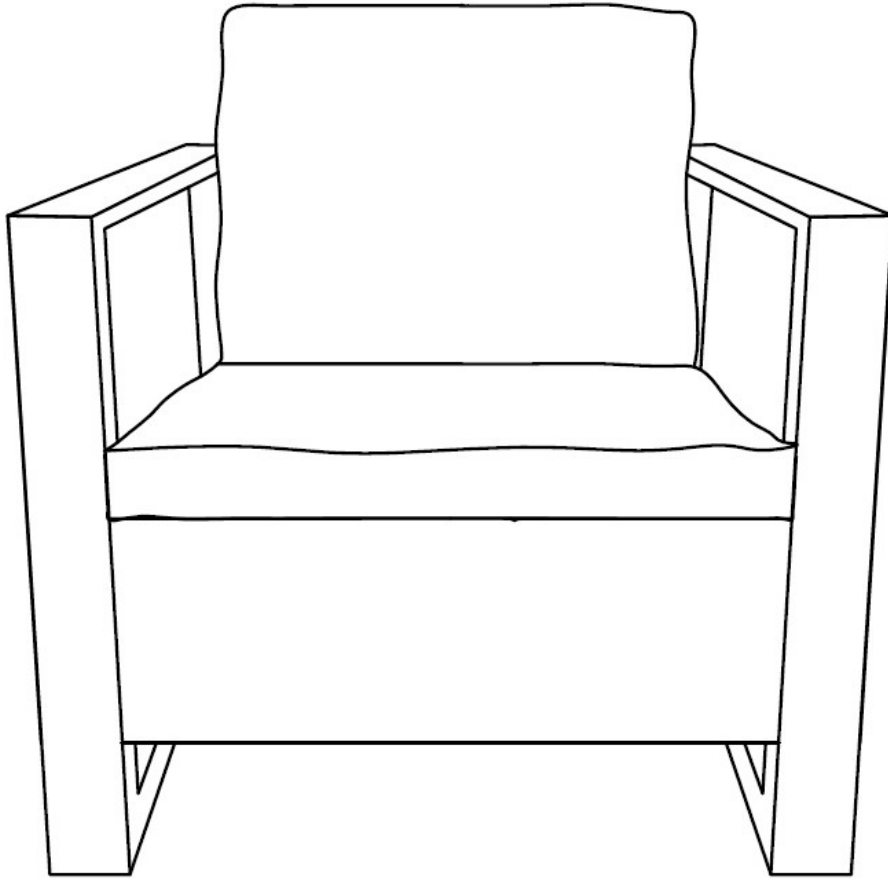





Assembly Instructions

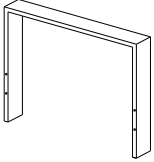
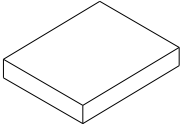
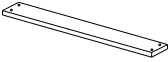

***Don't fully tighten all the bolts till the very end!**

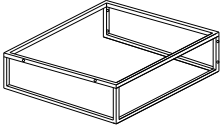
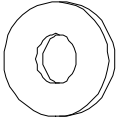
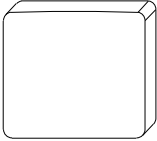

PRE-ASSEMBLY PREPARATION:

- Please read through the instructions before beginning assembly.
- Clear out the space for assembly and lay out all of the parts based on the Parts List, extra room will allow you to easily determine if all the pieces are present.
- Keep small parts and pieces away from children until fully assembled.

Part no.	Part	QTY	Image	Part no.	Part	QTY	Image
A	arm	2		F	Seat cushion	1	
B	foot	2		G	Bolt (M6*30mm)	8	
C	Back	1		H	Back cushion (M6*35mm)	14	
D	Seat	1		I	Washer M6	22	
E	Back cushion	1		J	Allen wrench	1	

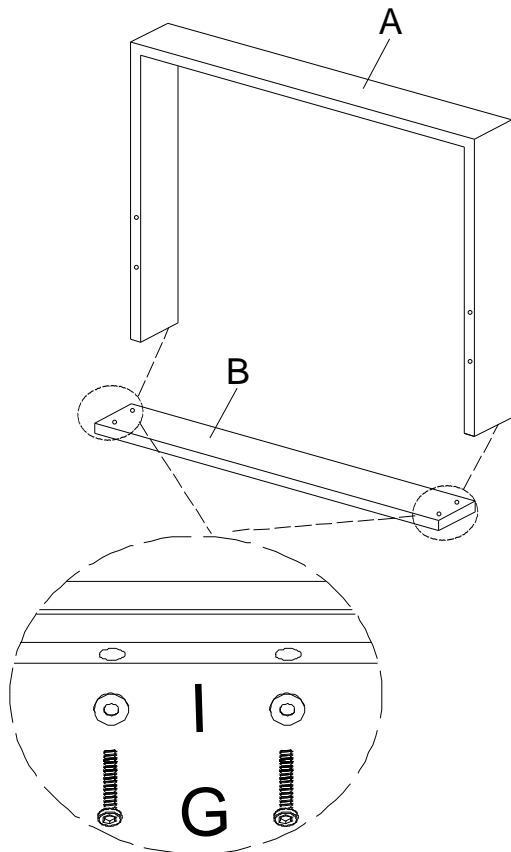

Step 1: Attach foot B to arm A with 4pcs bolts G and 4pcs washers I, using Allen wrench J. Repeat it to assemble the second arm and foot .



G		M6*30	8
I		Ø16*Ø6.5*1	8

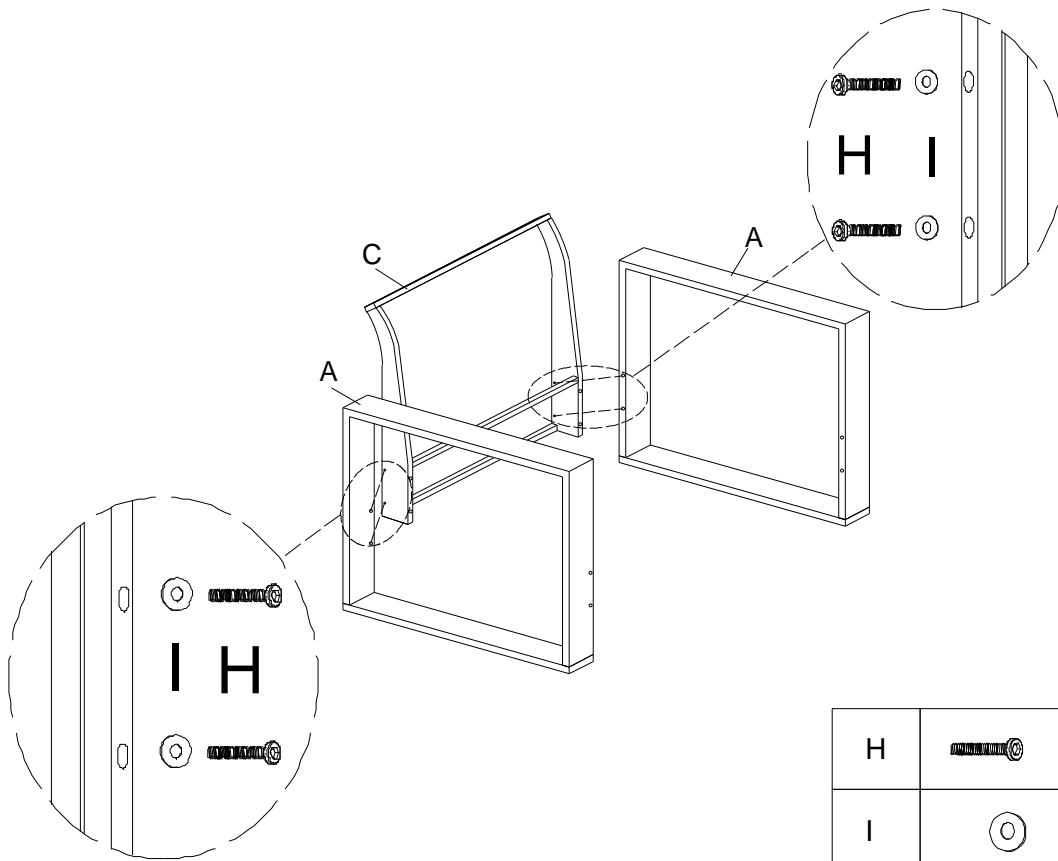

Step 2: Attach back C to arms A with 4pcs bolts H and 4pcs washers I, using Allen wrench J. Note: Don't fully tighten the bolts.



H		M6*35	4
I		Ø16*Ø6.5*1	4

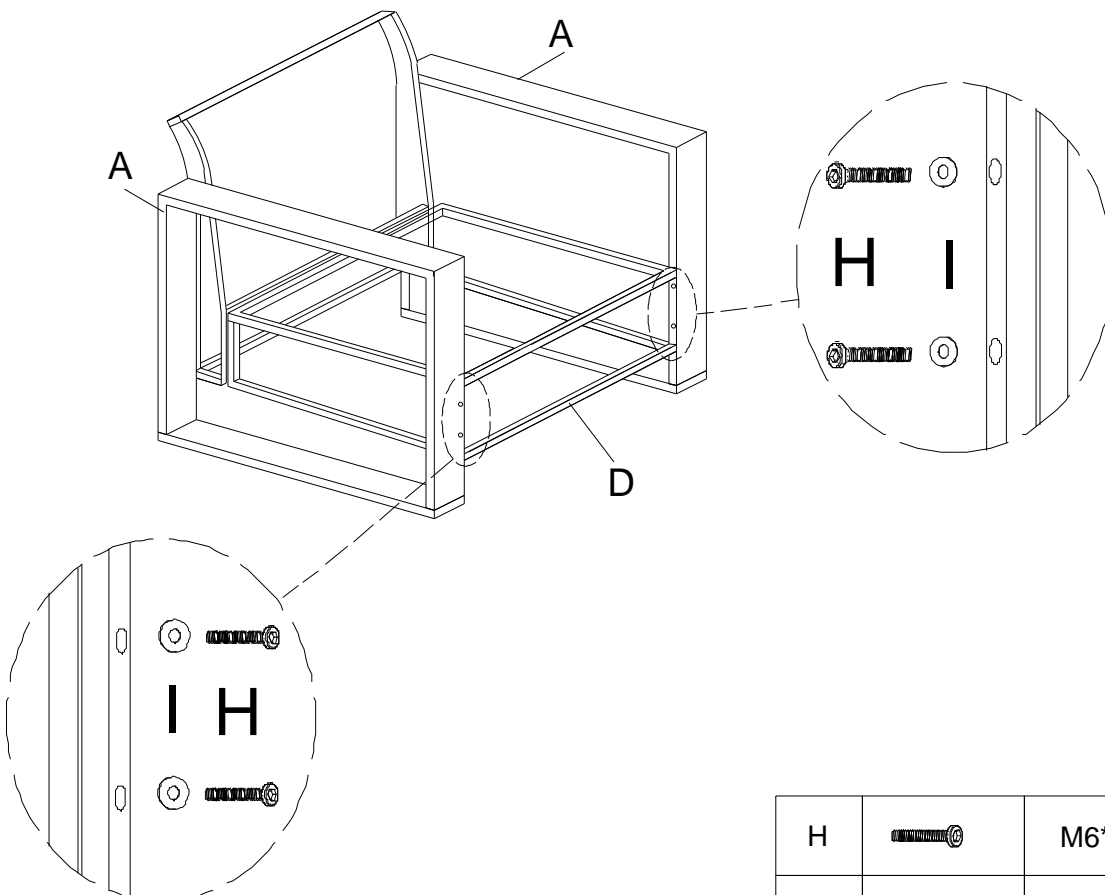

Step 3: Attach seat D to arms A with 4pcs bolts H and 4pcs washers I, using Allen wrench J. Note: Don't fully tighten the bolts.

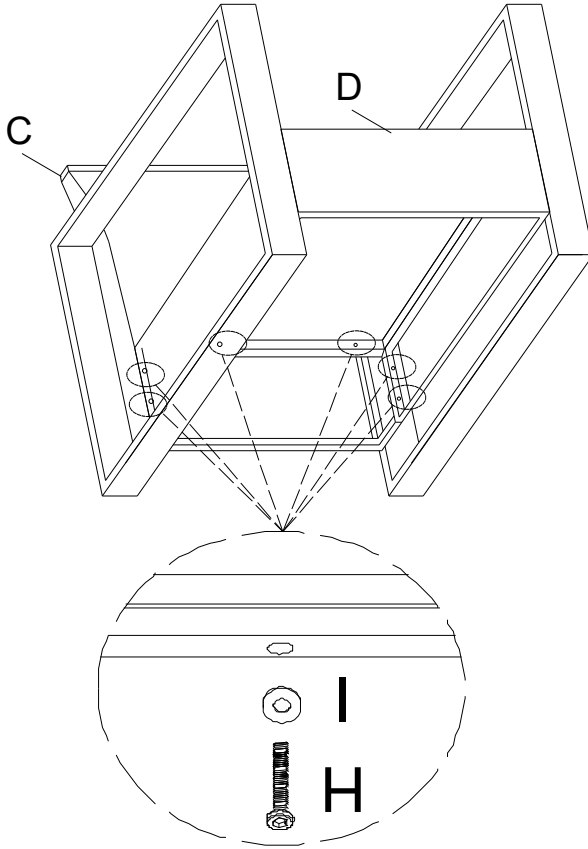

H		M6*35	4
I		Ø16*Ø6.5*1	4

Step 4: Attach seat D to back C with 6pcs bolts H and 6pcs washers I, using Allen wrench J. Note: Please fully tighten all the bolts.



H		M6*35	6
I		Ø16*Ø6.5*1	6

Step 5: Put back cushion E and seat cushion F onto the seat . Assembly is now complete and the product is ready for use.

