

DE:Installationsanleitung
 UK:Installation Instruction
 FR:Instruction d'installation
 IT:Istruzioni di installazione
 ES: Instrucciones de instalación
 NL: Installatie-instructies
 SE: Installationsanvisningar
 PL:Instrukcje instalacji
 N620P356086/N620P356087

DE:Unser Produkt wird Ihnen in 2 Paketen geliefert. Die Lieferzeiten dieser 2 Pakete können abweichen, bitte haben Sie etwas Geduld und vielen Dank für Ihr Verständnis.

UK:Our product will be delivered to you in 2 packages. The delivery times of these 2 packages may differ, please be patient and thank you for your understanding.

FR:Notre produit vous sera livré en 2 colis. Les délais de livraison de ces 2 colis peuvent différer, soyez patient et merci pour votre compréhension.

IT: Il nostro prodotto verrà consegnato in 2 pacchi. I tempi di consegna di questi 2 pacchi possono variare; vi preghiamo di avere un po' di pazienza e vi ringraziamo per la vostra comprensione.

ES: Nuestro producto se entregará en 2 paquetes. Los tiempos de entrega de estos 2 paquetes pueden variar; por favor, tenga un poco de paciencia y gracias por su comprensión.

NL: Ons product wordt in 2 pakketten bij u geleverd. De levertijden van deze 2 pakketten kunnen verschillen, we vragen om uw geduld en bedanken u voor uw begrip.

SE: Vår produkt kommer att levereras till dig i 2 paket. Leveranstiderna för dessa 2 paket kan variera, vi ber om ditt tålmod och tackar för din förståelse.

PL: Nasz produkt zostanie dostarczony w 2 paczkach. Czas dostawy tych 2 paczek może się różnić, prosimy o cierpliwość i dziękujemy za zrozumienie.

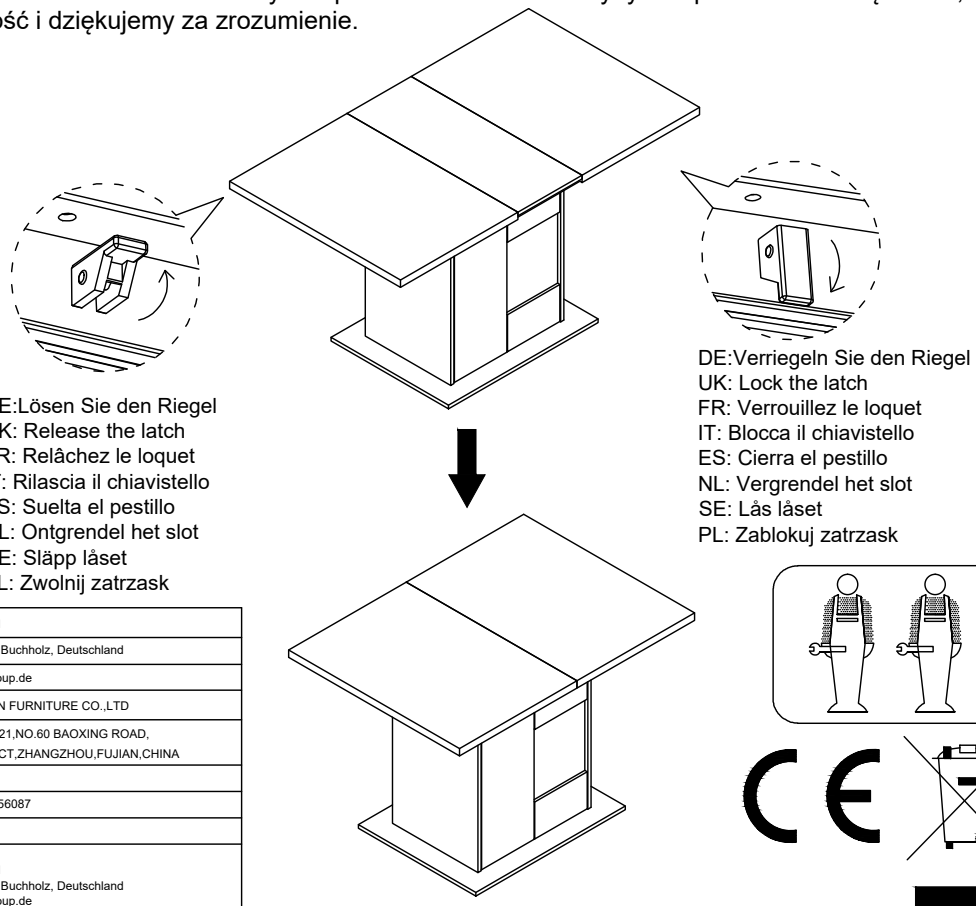

DE:Lösen Sie den Riegel
 UK: Release the latch
 FR: Relâchez le loquet
 IT: Rilascia il chiavistello
 ES: Suelta el pestillo
 NL: Ontgrendel het slot
 SE: Släpp låset
 PL: Zwolnij zatrzask

DE:Verriegeln Sie den Riegel
 UK: Lock the latch
 FR: Verrouillez le loquet
 IT: Blocca il chiavistello
 ES: Cierra el pestillo
 NL: Vergrendel het slot
 SE: Lås låset
 PL: Zablokuj zatrzask

Importeur	Decobus Handel GmbH
Adresse	Innungsstraße 9,21244 Buchholz, Deutschland
URL	https://www.decobusgroup.de
Hersteller	ZHANGZHOU SHUJIAN FURNITURE CO.,LTD
Adresse	ROOM 101,BUILDING 21,NO.60 BAOXING ROAD, XIANGCHENG DISTRICT,ZHANGZHOU,FUJIAN,CHINA
Email/URL	Freja_zsj@163.com
Partienummer	N620P356086/N620P356087
Hergestellt in	CHINA
EC REP	Decobus Handel GmbH Innungsstraße 9,21244 Buchholz, Deutschland https://www.decobusgroup.de

	
M3.5x14mm	M3.5x14mm
Ⓔ x8pcs	Ⓕ x44pcs

DE: Bitte beachten Sie, dass die Formen der Schrauben E und H ähnlich sind. Bitte installieren Sie entsprechend der Anleitung und unterscheiden Sie sie!

UK: Please note that the shapes of screws E and H are similar. Please install according to the instructions and distinguish them

FR: Notez que les vis E et H ont des formes similaires. Veuillez les installer en suivant les instructions pour les séparer!

IT: Si prega di notare che le forme delle viti E e H sono simili. Si prega di installarle seguendo le istruzioni e di distinguerle!

ES: Por favor, tenga en cuenta que las formas de los tornillos E y H son similares. Por favor, instálelos de acuerdo con las instrucciones y distíngalos.

NL: Let op, de vormen van schroeven E en H zijn vergelijkbaar. Installeer volgens de instructies en maak onderscheid tussen ze!

SE: Observera att formerna på skruvarna E och H är lika. Installera enligt anvisningarna och särskilj dem!

PL: Zauważ, że kształty śrub E i H są podobne. Zainstaluj zgodnie z instrukcjami i rozróżnij je!

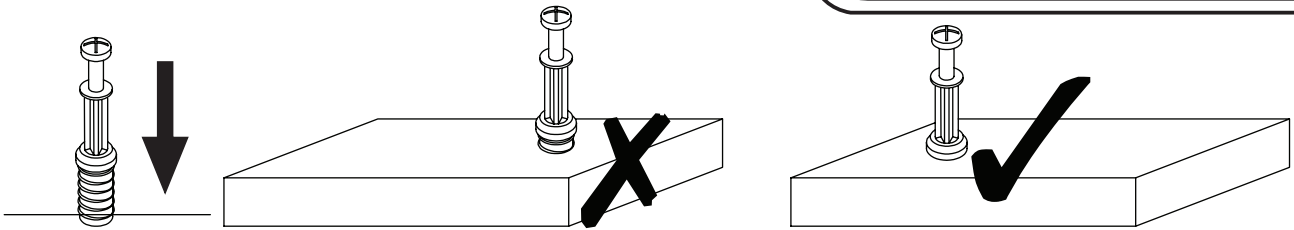

EN_QUICKFIT: Tighten quickfit until shoulder is flush with panel. Do not overtighten or undertighten.

FR_RACCORD RAPIDE: Faites serrer le raccord rapide jusqu'à ce que l'épaulement soit parfaitement encastré dans le panneau. Il ne faut ni trop serrer ni insuffisamment serrer.

ES_QUICKFIT: Apriete quickfit hasta que el hombro se descargue con el panel. NO lo sobreapriete ni lo apriete poco.

DE_QUICKFIT: Ziehen Sie den Quickfit fest, bis die Schulter mit der Platte bündig ist. Bitte nicht zu fest oder zu schwach anziehen.

IT_MONTAGGIO RAPIDO: Stringere il montaggio rapido fino a quando la spalla è a filo con il pannello, non stringere troppo o troppo poco.

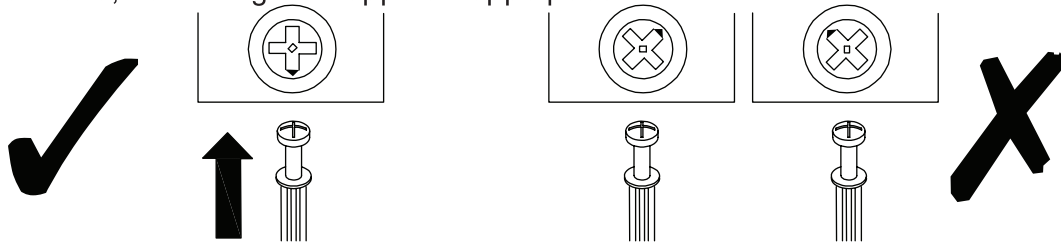

EN_CAM LOCK: When fitting cam lock, ensure starting position is correct before you insert connecting quickfit.

FR_SERRURE BATTEUSE: Avant d'insérer la serrure batteuse, veillez à la bonne orientation avant d'insérer le raccord rapide.

ES_CIERRE DE LA CÁMARA: Cuando instale el cierre de la cámara, asegúrese de que la posición de inicio es correcta antes de que inserte el quickfit conector.

DE_CAM-LOCK: Achten Sie bei der Montage des Cam-Locks auf die richtige Ausgangsposition, bevor Sie den Quickfit einsetzen.

IT_BLOCCAGGIO A CAMMA: Quando si monta il bloccaggio a camma, assicurarsi che la posizione iniziale sia corretta prima di inserire il montaggio rapido di collegamento.

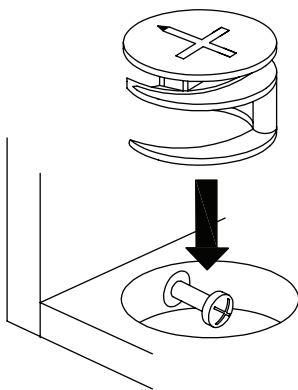

EN_Quickfit head should be in the centre of the cam lock when the two panels are joined.

Cam lock should be inserted before quickfit.

FR_Lorsque les deux panneaux sont assemblés, la tête du raccord rapide doit reposer au centre de la serrure batteuse. Il faut insérer la serrure batteuse avant le raccord rapide.

ES_El cabezal del quickfit debe estar en el centro del cierre de la cámara cuando se unan los dos paneles.

Se debe insertar el cierre de la cámara antes que el quickfit.

DE_Der Quickfit-Kopf sollte sich in der Mitte des Cam-Locks befinden, wenn die beiden Platten zusammengefügt sind. Der Cam-Lock sollte vor dem Quickfit eingesetzt werden.

IT_La testa del montaggio rapido deve trovarsi al centro del bloccaggio a camma quando i due pannelli sono uniti. Il Bloccaggio a Camma deve essere inserito prima del montaggio rapido.

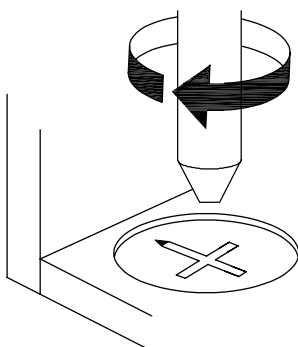

EN_Turn cam lock clockwise to tighten.

FR_Faites tourner la serrure batteuse dans le sens des aiguilles d'une montre pour la resserrer.

ES_Gire el cierre de la cámara en sentido horario para apretarlo.

DE_Drehen Sie den Cam-Lock im Uhrzeigersinn, um ihn festzuziehen.

IT_Ruotare il bloccaggio a camma in senso orario per stringere.

DE:Vor dem Einbau die Schrauben in die Löcher stecken und festziehen, aber nicht bis 100%, 70% bis 80% anziehen reicht aus. Schließlich, nachdem alle Schrauben installiert sind, ziehen Sie alle Schrauben auf 100%.Wenn Sie auf diese Probleme stoßen, wie z. B. Fehlausrichtung der Löcher oder Unfähigkeit, bestimmte Teile zu installieren, überprüfen Sie bitte, ob die Schrauben korrekt verwendet werden und passen Sie die Dichtigkeit der Schrauben an.

UK:Before installation, insert the screws into the holes and tighten them, but do not tighten them to 100%, 70% to 80% is sufficient. Finally, after all screws are installed, tighten all screws to 100%.If you encounter these issues, such as if the holes cannot be aligned or some parts cannot be installed, please check if the screws are used correctly and adjust the tightness of the screws.

FR:Insérer la vis dans le trou avant la fin de l'assemblage, serrer la vis, mais ne pas serrer à 100%, 70% ~ 80% est correct. Enfin, une fois que toutes les vis sont bien serrées, toutes les vis sont serrées à 100%.Si vous rencontrez ces problèmes, par exemple si les trous ne sont pas alignés ou si certaines pièces ne peuvent pas être montées, vérifiez que les vis sont utilisées correctement et Ajustez leur serrage.

IT:Prima dell'installazione, inserire le viti nei fori e stringerle, ma non al 100%, è sufficiente stringerle al 70% - 80%. Infine, dopo aver installato tutte le viti, stringere tutte le viti al 100%. Se riscontri problemi come disallineamenti dei fori o difficoltà nell'installare alcuni componenti, verifica che le viti siano utilizzate correttamente e regola la tensione delle viti.

ES:Antes de la instalación, coloque los tornillos en los agujeros y apriéte los, pero no al 100%; apretar al 70% - 80% es suficiente. Finalmente, después de haber instalado todos los tornillos, apriete todos los tornillos al 100%. Si se encuentra con problemas como desalineación de los agujeros o dificultad para instalar ciertas piezas, verifique que los tornillos se estén utilizando correctamente y ajuste la tensión de los tornillos.

NL:Voordat u begint met de installatie, plaatst u de schroeven in de gaten en draait u ze aan, maar draai ze niet volledig aan; 70% tot 80% is voldoende. Draai uiteindelijk, nadat alle schroeven zijn geplaatst, alle schroeven volledig aan. Als u problemen ondervindt, zoals niet uitgelijnde gaten of onderdelen die niet kunnen worden geïnstalleerd, controleer dan of de schroeven correct zijn gebruikt en pas de spanning van de schroeven aan.

SE:Innan installation, sätt i skruvarna i hålen och dra åt dem, men dra inte åt dem helt; 70% till 80% är tillräckligt. Slutligen, när alla skruvar är installerade, dra åt alla skruvar helt. Om du stöter på problem, som att hålen inte kan justeras eller vissa delar inte kan installeras, kontrollera om skruvarna används korrekt och justera skruvarnas åtdragning.

PL:Przed instalacją wstaw śruby w otwory i dokręć je, ale nie dokręcaj ich na 100%; 70% do 80% wystarczy. Na koniec, po zainstalowaniu wszystkich śrub, dokręć wszystkie śruby do 100%. Jeśli napotkasz problemy, takie jak niedopasowane otwory lub części, które nie mogą być zainstalowane, sprawdź, czy śruby są używane prawidłowo i dostosuj ich dokręcenie.

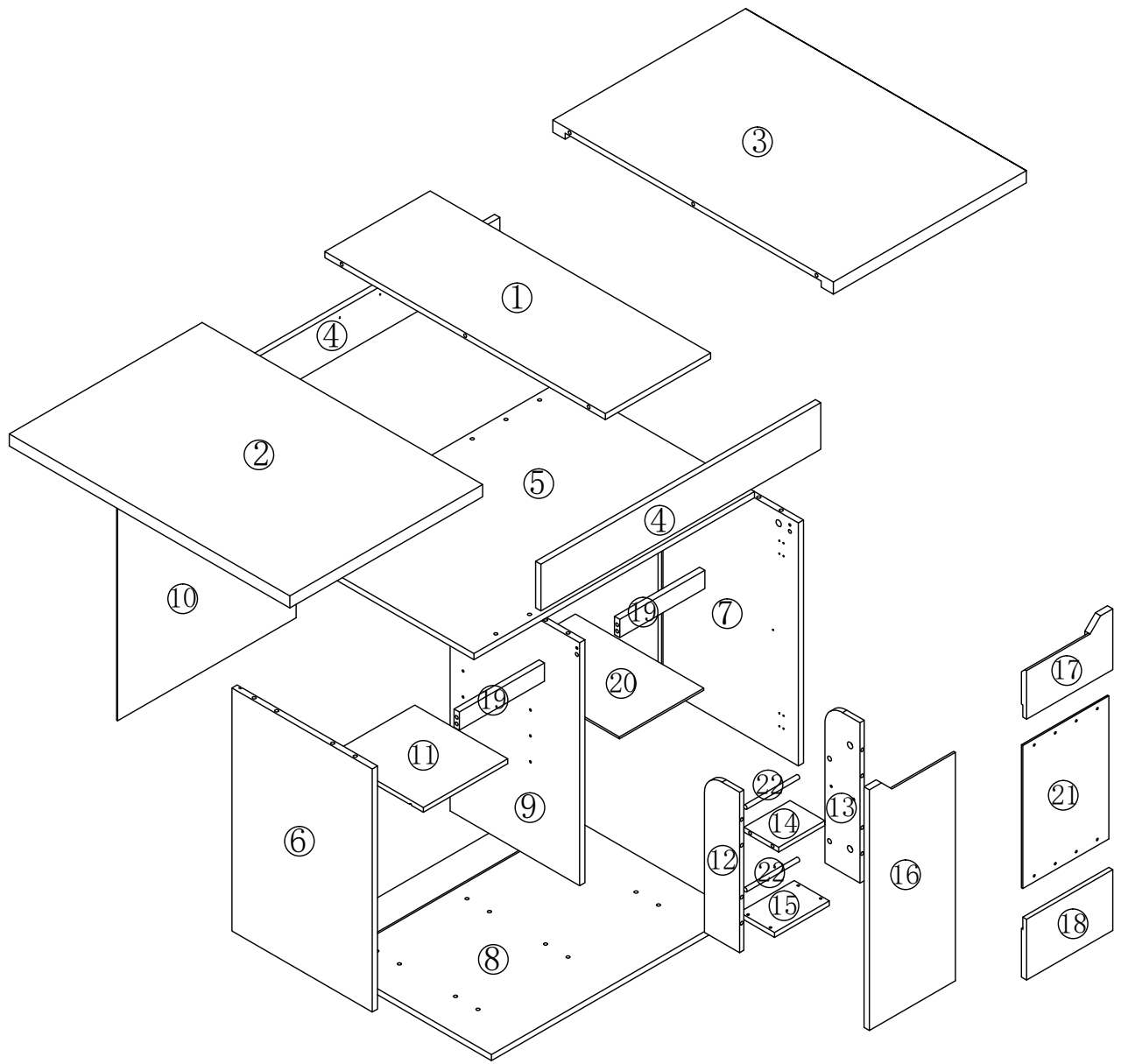

N620P356086

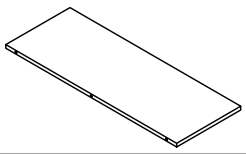
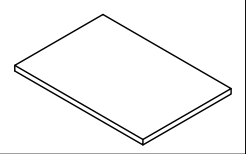
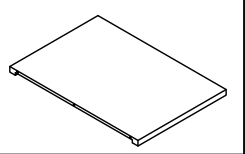
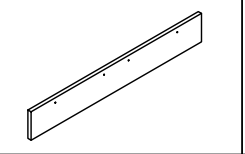
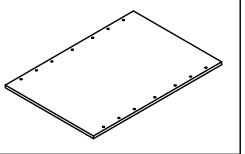
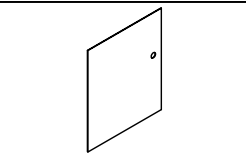



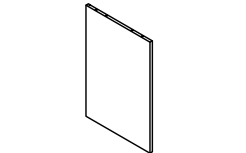
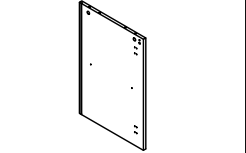
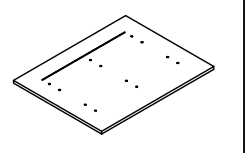
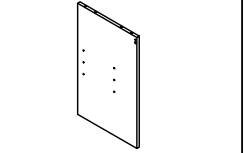
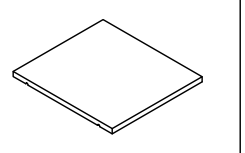
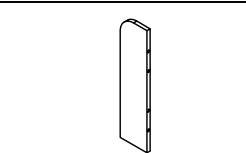
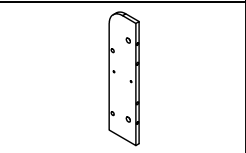
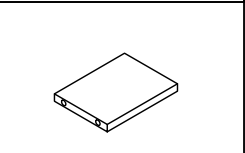
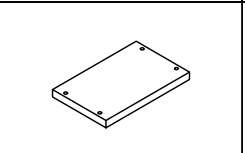
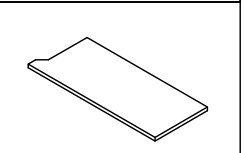
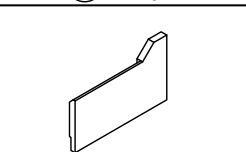
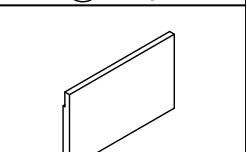
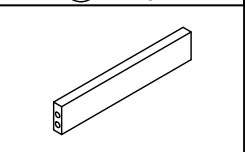
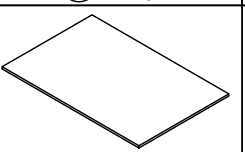
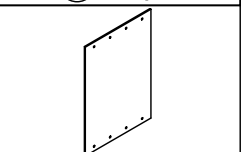
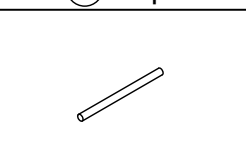





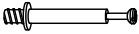







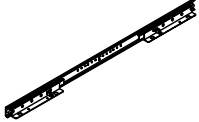

				
① x1pc	② x1pc	③ x1pc	④ x2pcs	⑤ x1pc
				
⑩ x1pc				

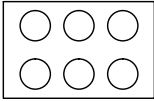
N620P356087

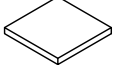
				
⑥ x1pc	⑦ x1pc	⑧ x1pc	⑨ x1pc	⑪ x1pc
				
⑫ x1pc	⑬ x1pc	⑭ x1pc	⑮ x1pc	⑯ x1pc
				
⑰ x1pc	⑱ x1pc	⑲ x2pcs	⑳ x1pc	㉑ x1pc
				
㉒ x2pcs				

Hardware List
Hardwareliste

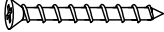

N620P356087

 Ø6x35mm A x18pcs	 Ø15x10mm B x18pcs	 Ø8x30mm C x24pcs	 M7x47mm D x14pcs	 M3.5x14mm E x8pcs
 Ø18x1.8mm F x8pcs	 M6x10mm G x8pcs	 M3.5x14mm H x44pcs	 I x8pcs	 J x2pcs
 Ø10x1.0mm K x8pcs	 Ø8x50mm L x1pc	 M x1pc	 N x1pc	 O x18pcs
 P x4pcs	 Q x6pcs	 R x4pcs	 S x1pc	 T x2pcs
 M4x40mm U x4pcs	 V x4pcs			

Step 1

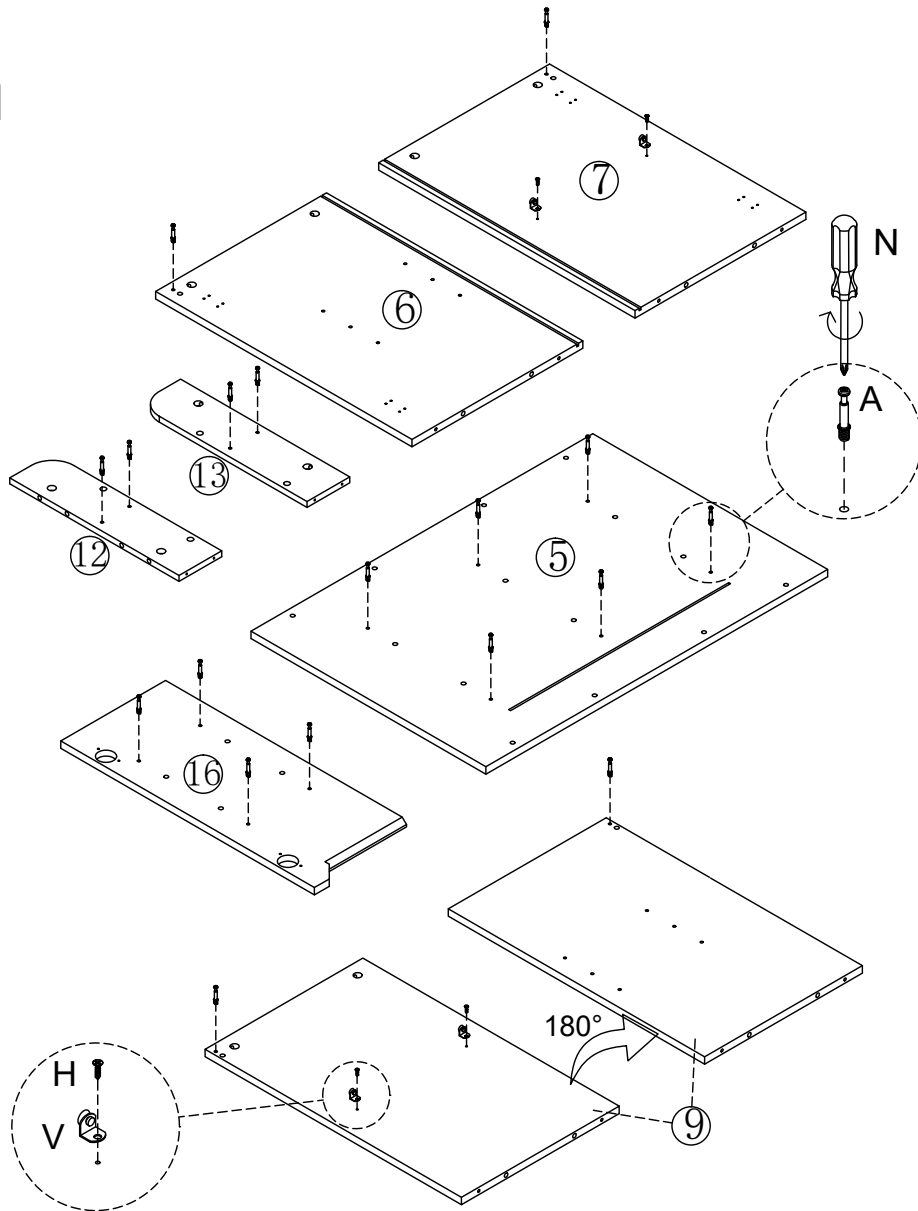
Schritt 1

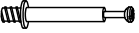



Ø6x35mm
Ⓐx18pcs

M3.5x14mm
Ⓗx4pcs

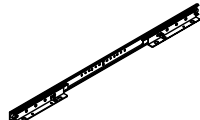
Ⓥx4pcs

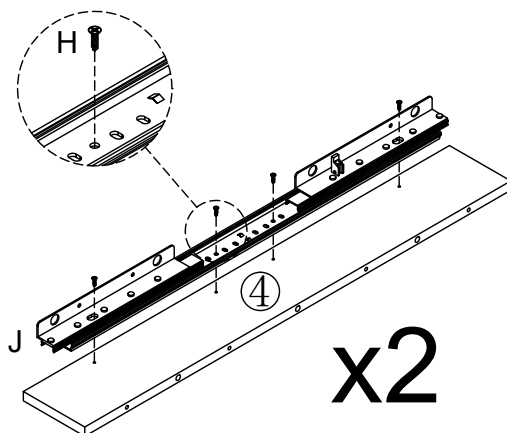
Step 2

Schritt 2

	
M3.5x14mm	
Ⓗx8pcs	Ⓝx2pcs



x2

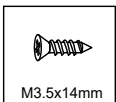
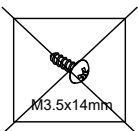

Step 3
Schritt 3

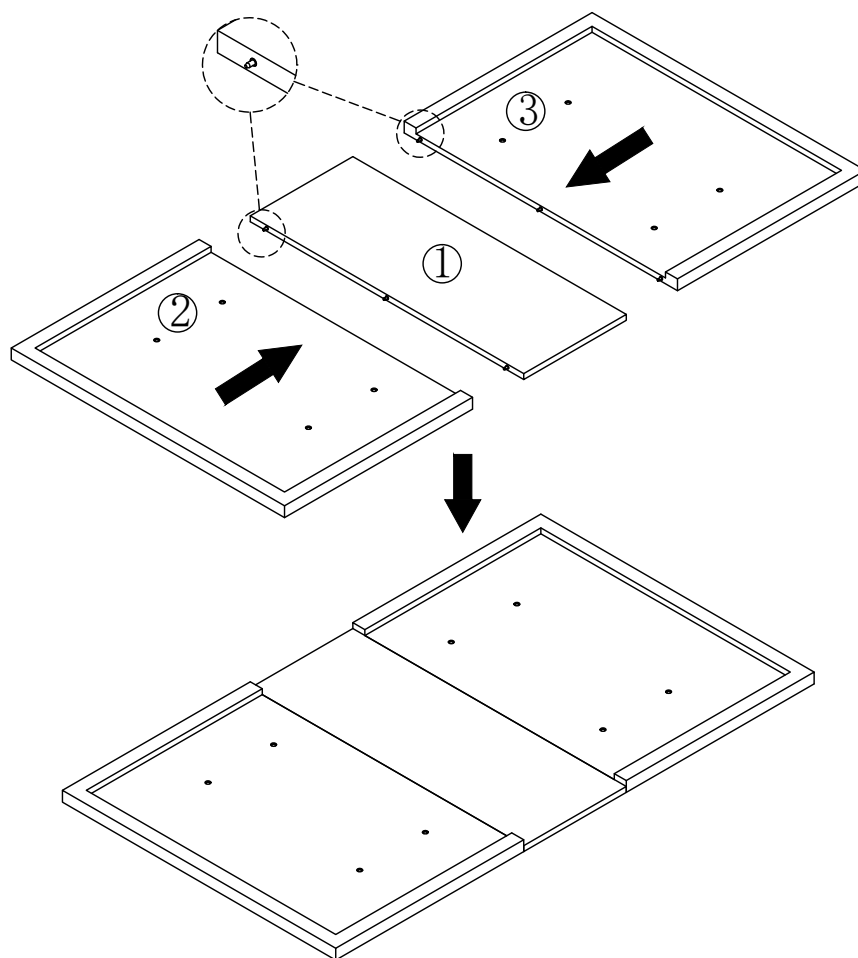

Step 4
Schritt 4

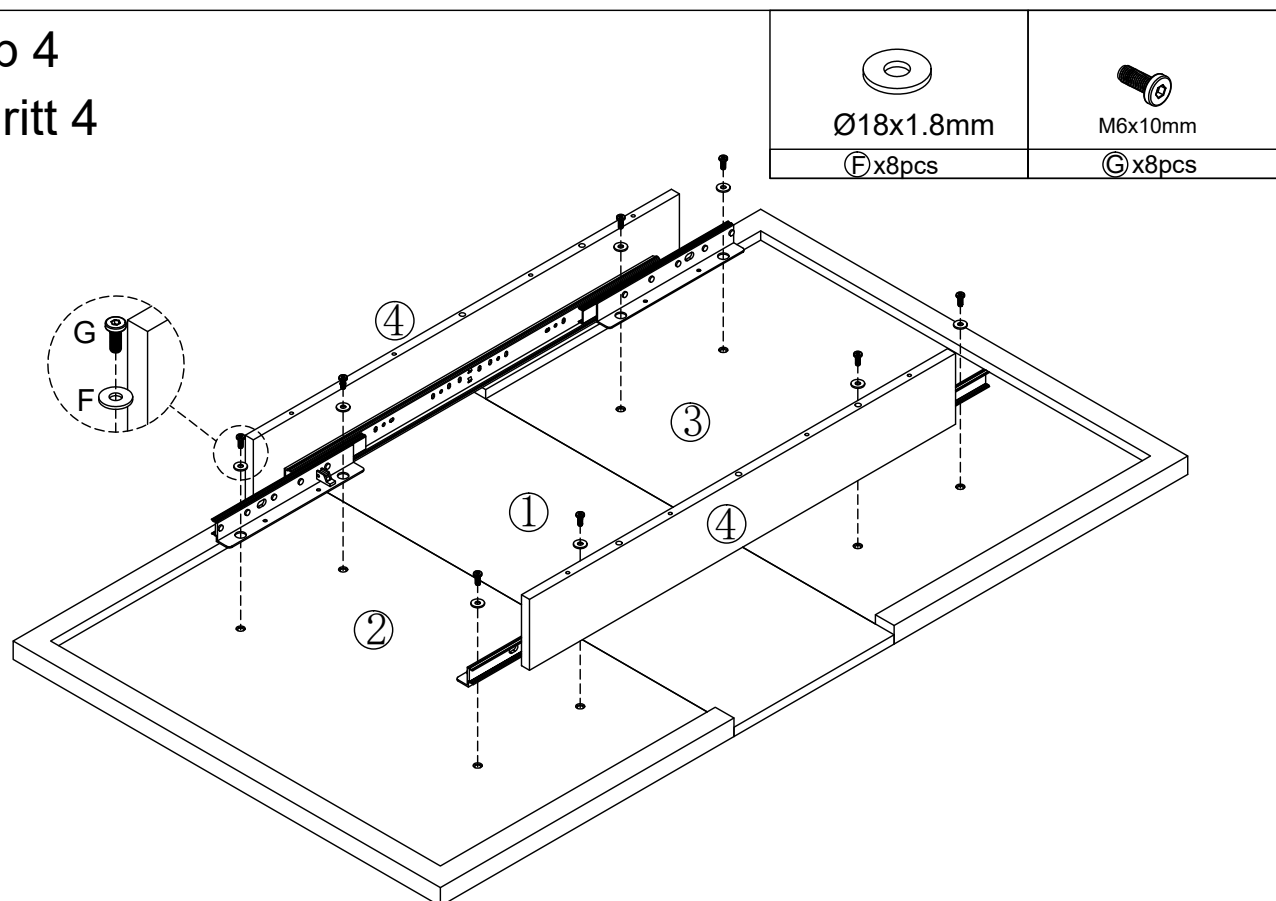

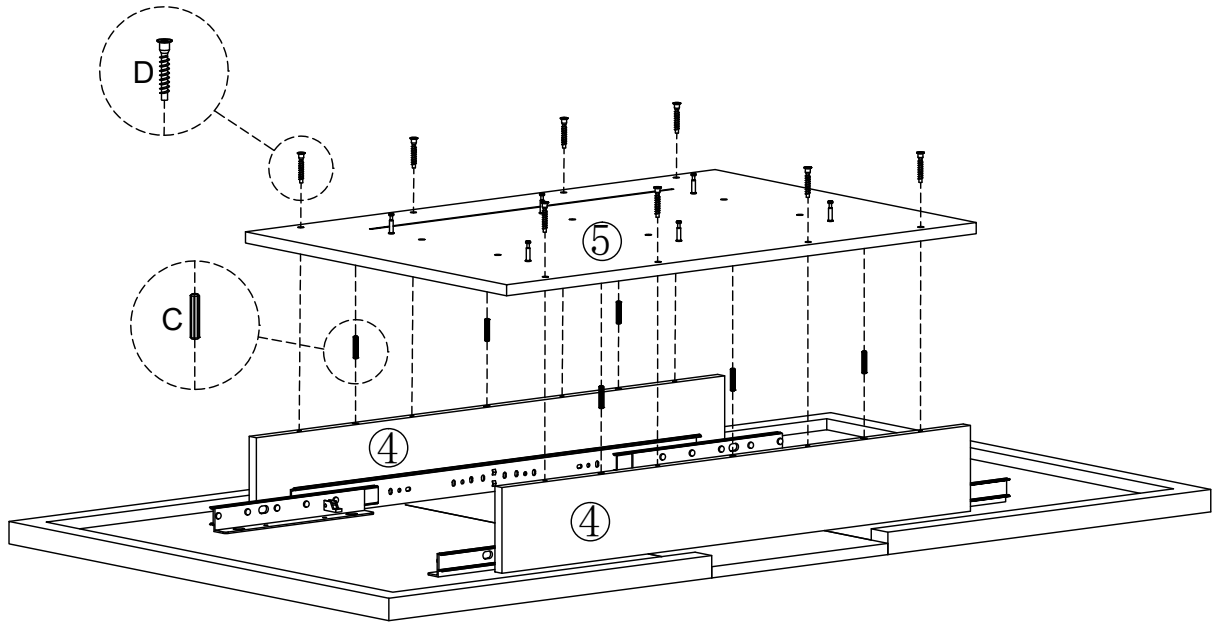

Step 5 Schritt 5

	
Ø8x30mm	M7x47mm
Ⓢx6pcs	Ⓢx8pcs



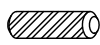
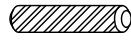

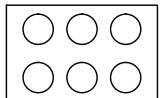
Step 6 Schritt 6

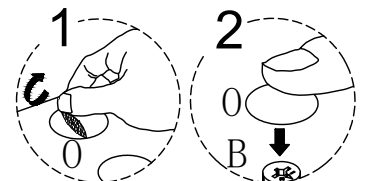
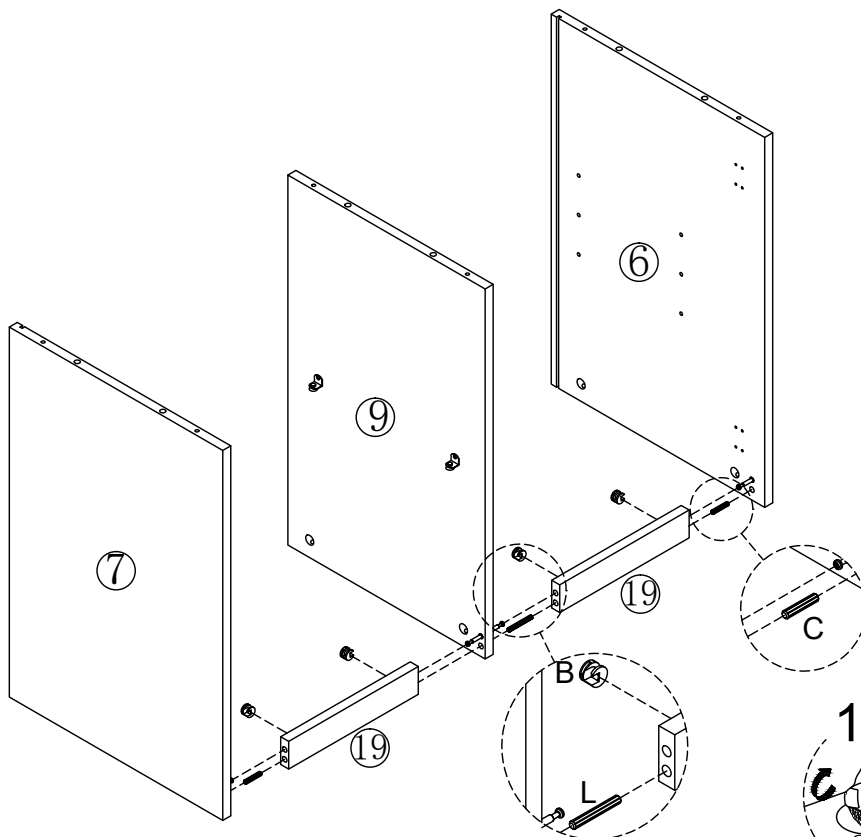
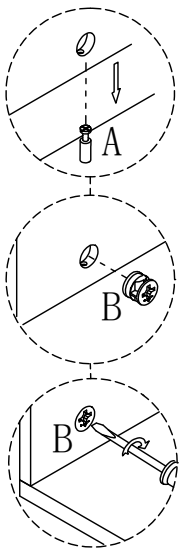
Ø8x30mm
Ⓢx2pcs

Ø8x50mm
Ⓢx1pc

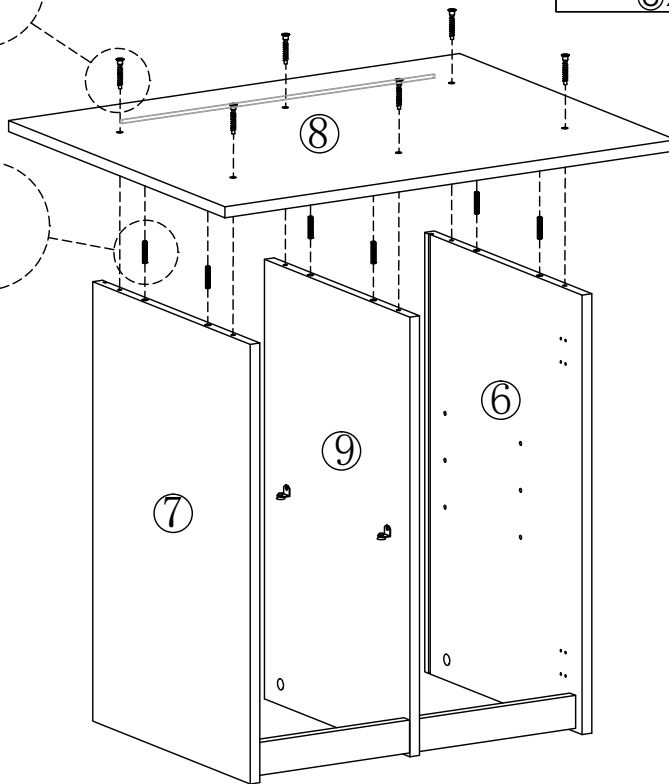
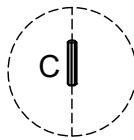
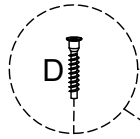
Ø15x10mm
Ⓢx4pcs

Ⓢx4pcs



Step 7
Schritt 7



	
Ø8x30mm	M7x47mm
ⓐ x6pcs	ⓓ x6pcs

Step 8
Schritt 8

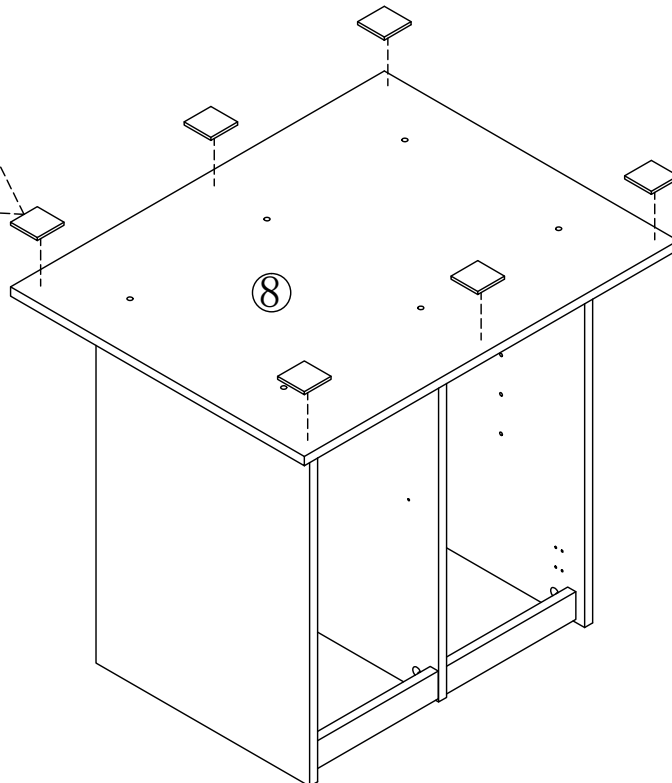
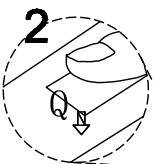
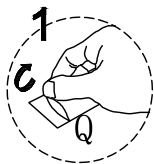

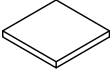

ⓐ x6pcs

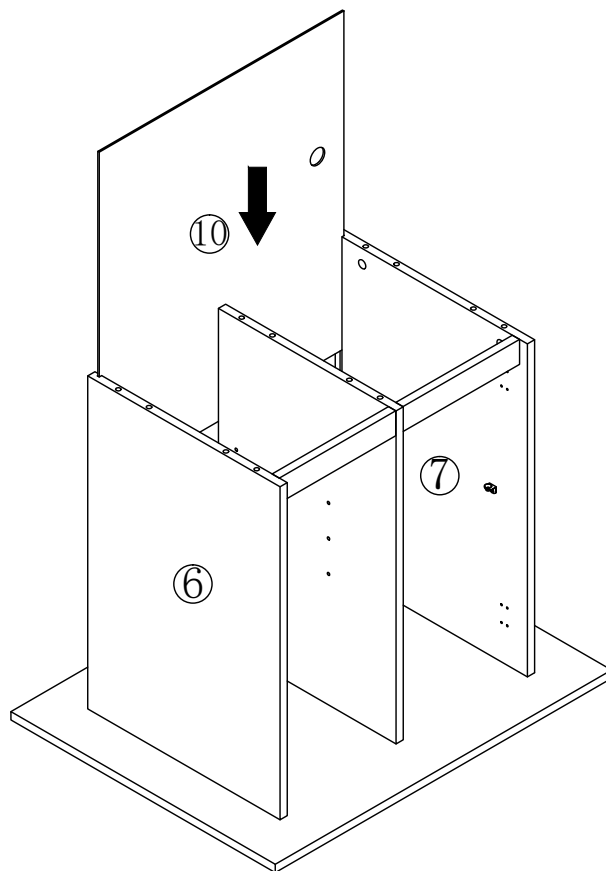
Step 9
Schritt 9

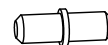
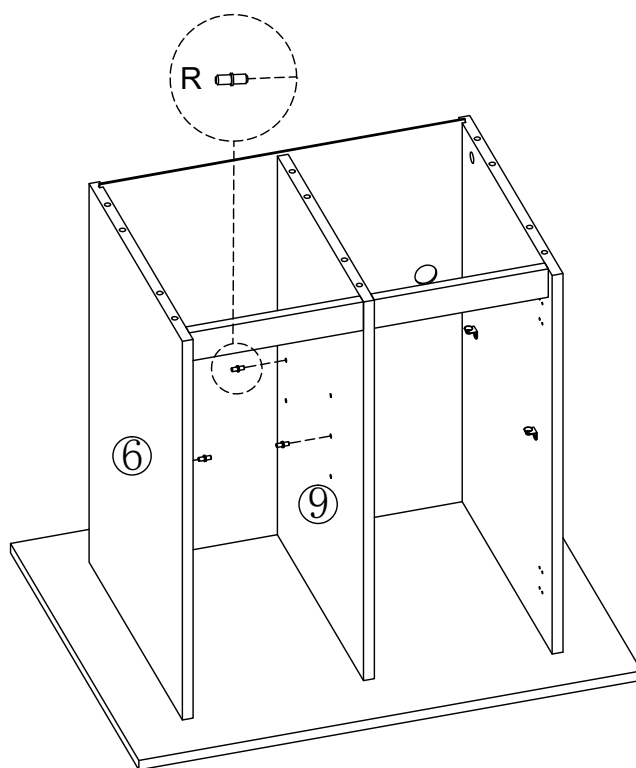

Step 10
Schritt 10



Ⓜ x4pcs

Step 11
Schritt 11

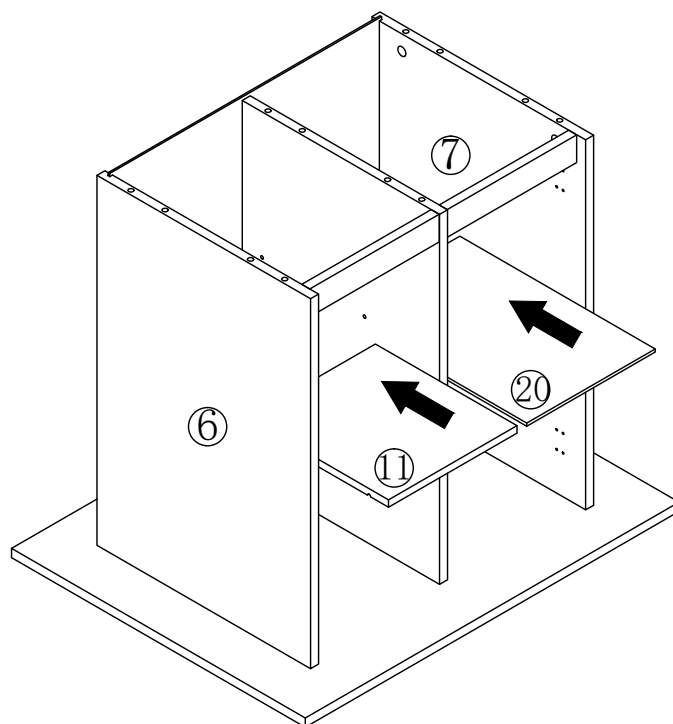

Step 12
Schritt 12

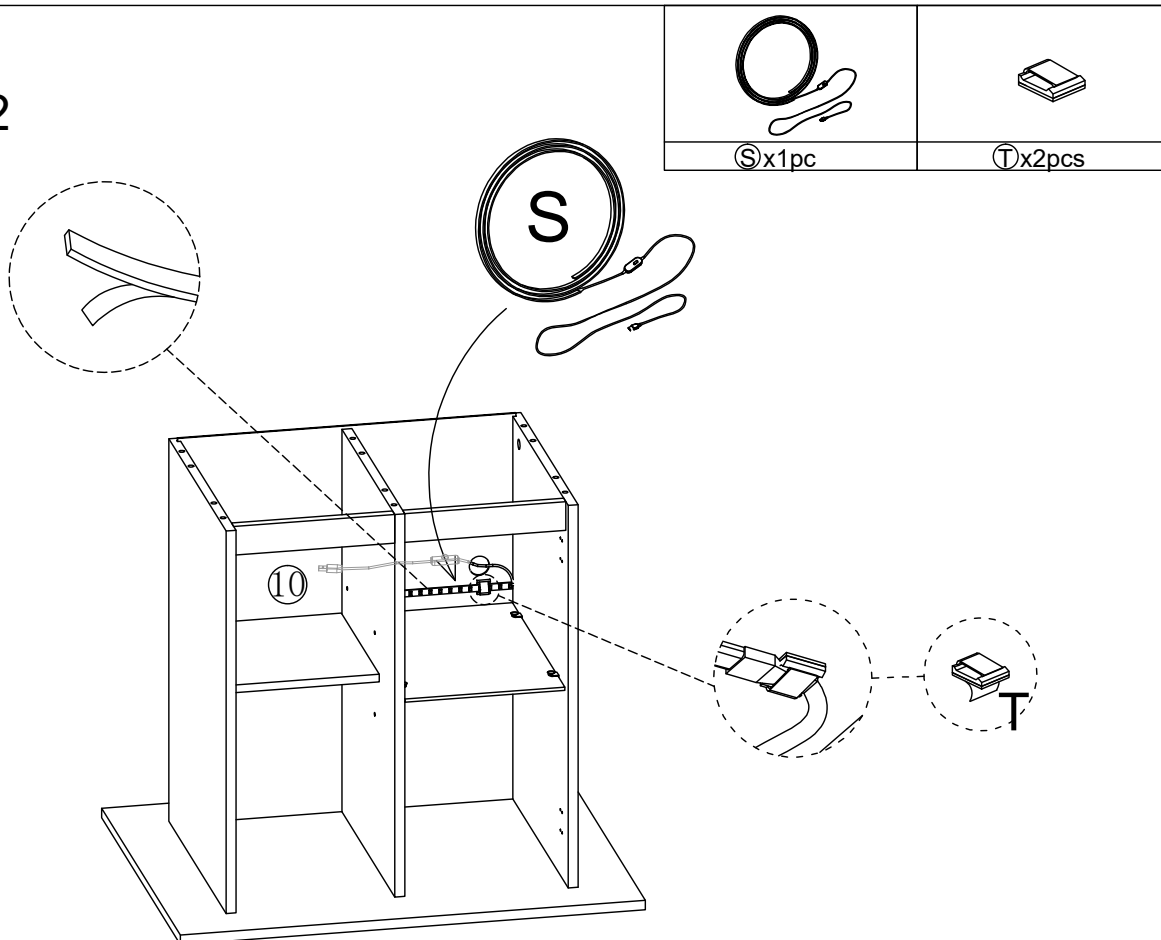

Step 13

Schritt 13

ⓐ x6pcs	ⓑ Ø15x10mm	ⓒ Ø8x30mm
	ⓑ x6pcs	ⓒ x6pcs

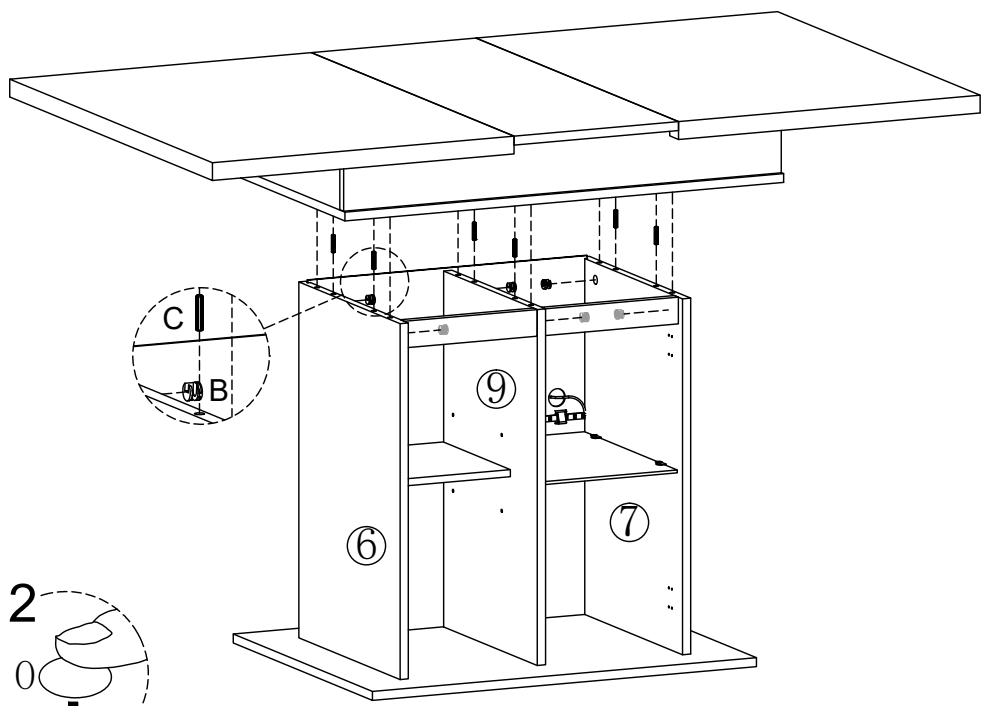
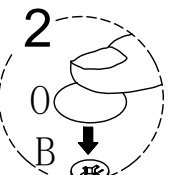
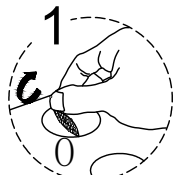
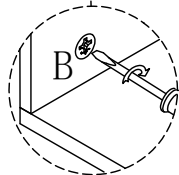
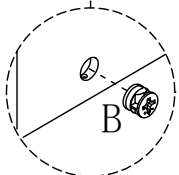
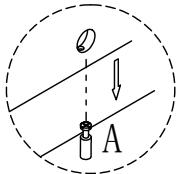



Step 14

Schritt 14

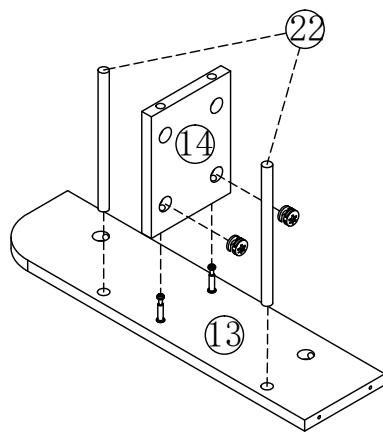
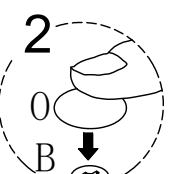
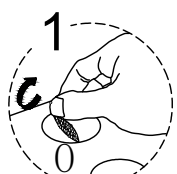
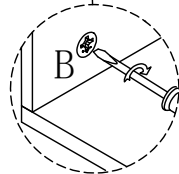
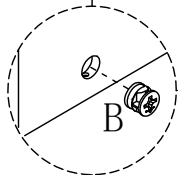
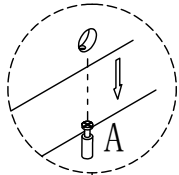
ⓐ x2pcs	ⓑ Ø15x10mm
	ⓑ x2pcs

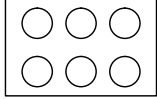

Step 15
Schritt 15

	
⊙ x2pcs	⊕15x10mm
	Ⓚ x2pcs

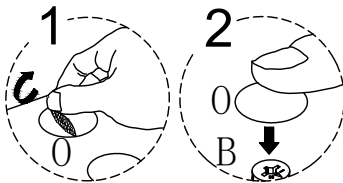
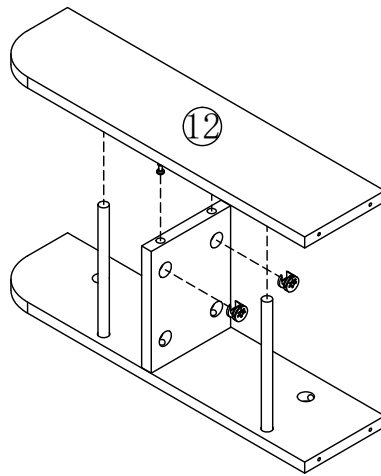
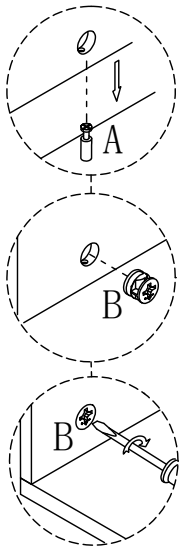

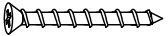

Step 16
Schritt 16

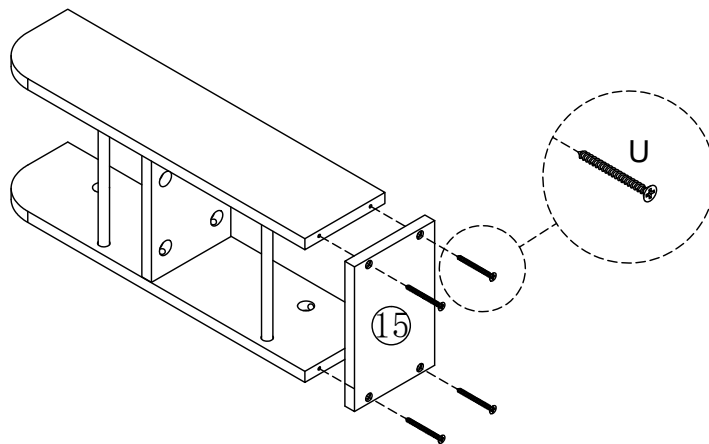

M4x40mm
Ⓚ x4pcs

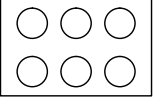

Step 17

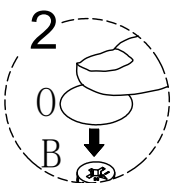
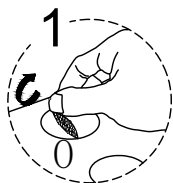
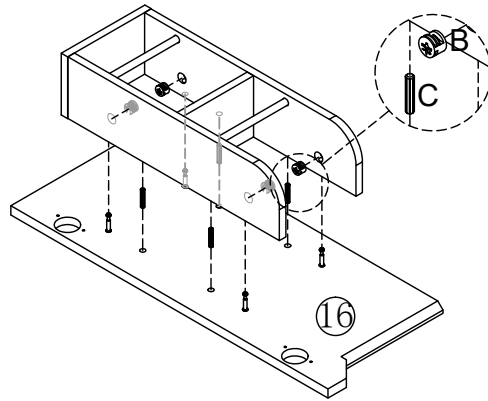
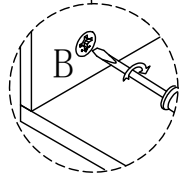
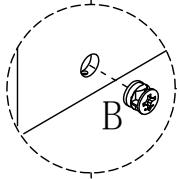
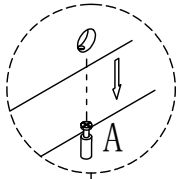

Schritt 17

		
ⓐ x4pcs	ⓑ x4pcs	ⓒ x4pcs



Step 18

Schritt 18

	
Ⓚ x8pcs	ⓔ x8pcs

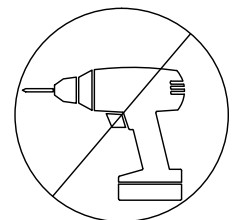
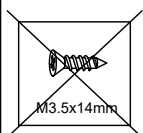
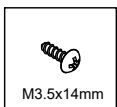
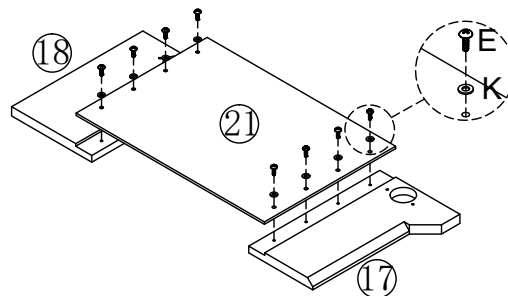

Step 19

Schritt 19

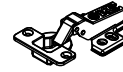

Ⓟx4pcs



M3.5x14mm

Ⓜx8pcs

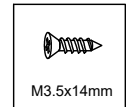
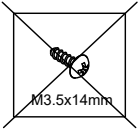
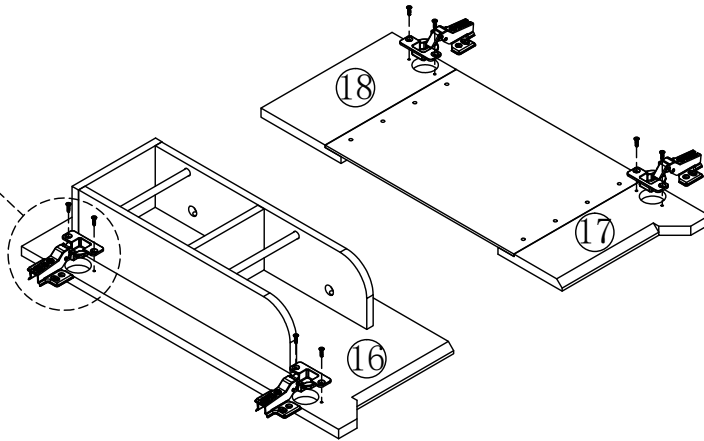
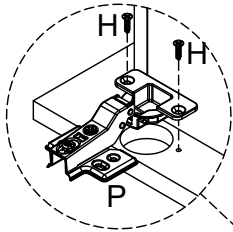

Step 20

Schritt 20



M3.5x14mm

Ⓜx8pcs

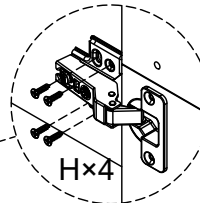
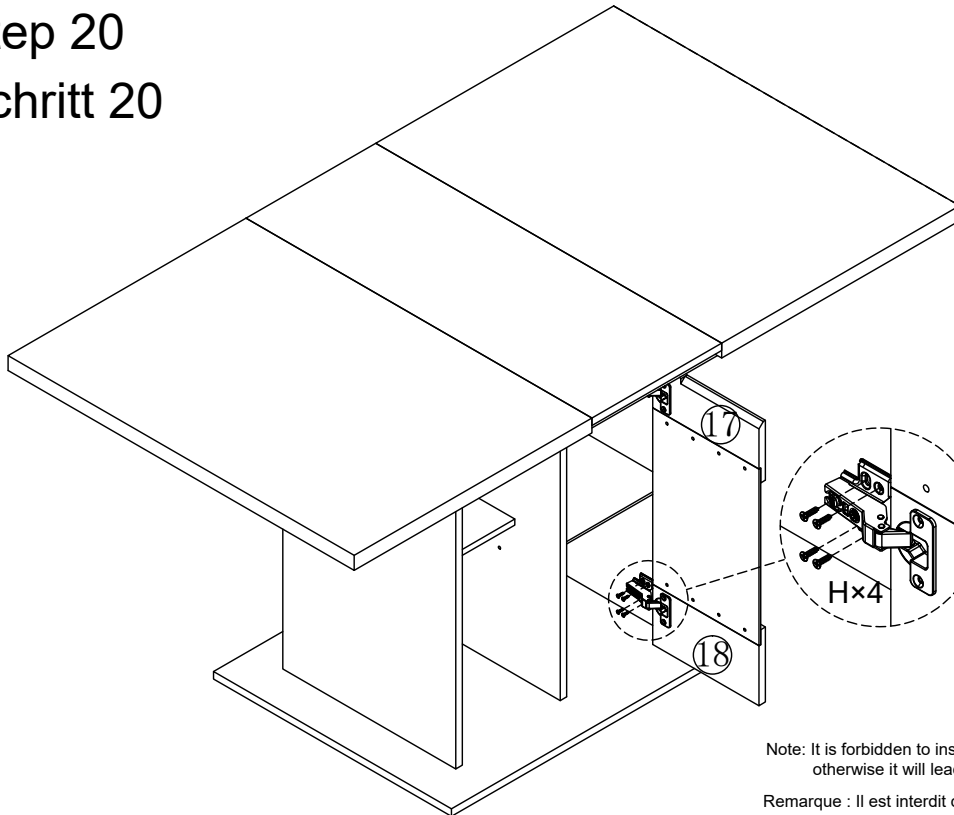

Note: It is forbidden to install the fixing hole screws first, otherwise it will lead to installation failure!

Remarque : Il est interdit d'installer d'abord les vis du trou de fixation, sinon cela entraînera un échec de l'installation !

Hinweis: Es ist verboten, zuerst die Befestigungslochschraben zu montieren, da dies sonst zu einem Installationsfehler führt!

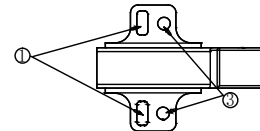

- ① Installez d'abord les vis du trou de réglage
- ② Mettez la porte dans la bonne position
- ③ Montieren Sie abschließend die Befestigungslochschraben

- ① Install the adjustment hole screws first
- ② Get the door in the right position
- ③ Finally, install the fixing hole screws

- ① Montieren Sie zuerst die Einstellochschraben
- ② Bringen Sie die Tür in die richtige Position
- ③ Enfin, installez les vis du trou de fixation

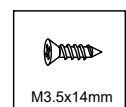
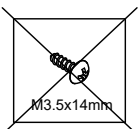

Step 21

Schritt 21



M3.5x14mm

(H)x8pcs

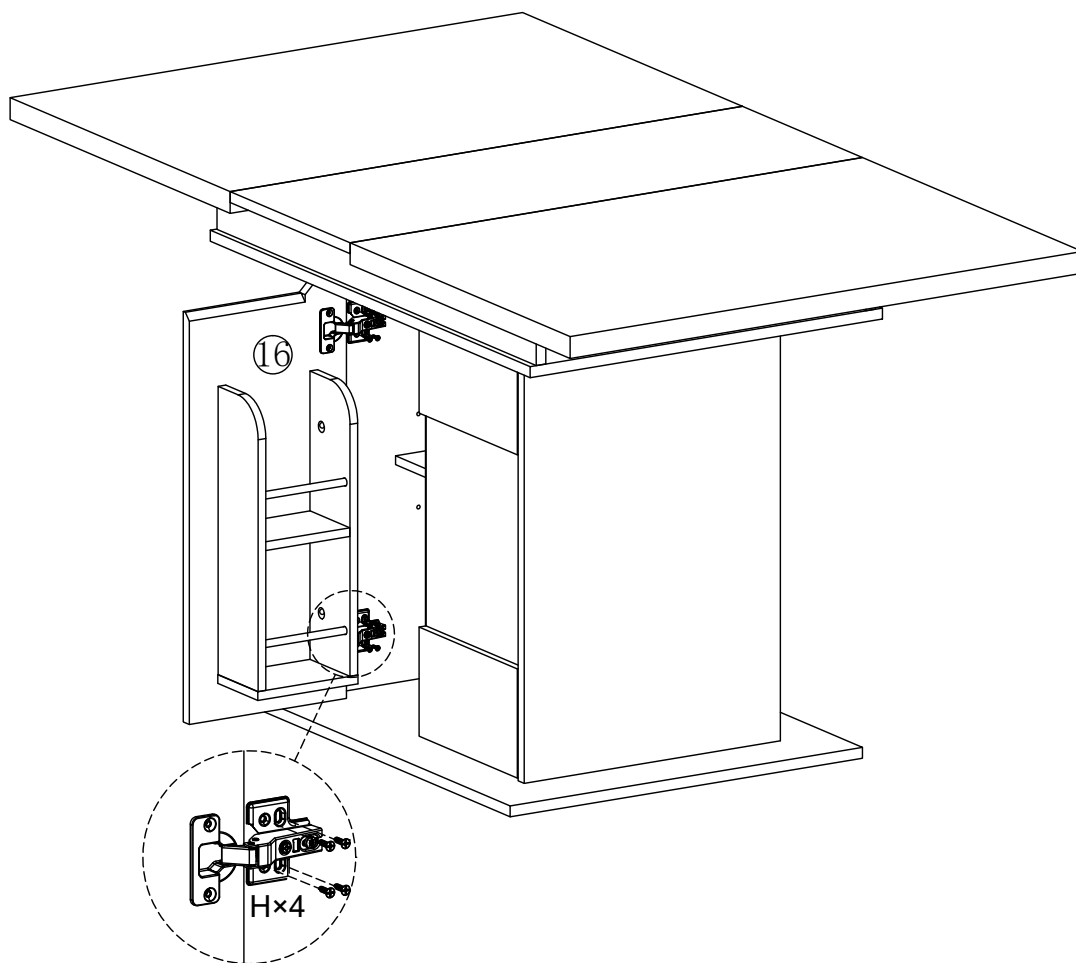

Note: It is forbidden to install the fixing hole screws first, otherwise it will lead to installation failure!

Remarque : Il est interdit d'installer d'abord les vis du trou de fixation, sinon cela entraînera un échec de l'installation !

Hinweis: Es ist verboten, zuerst die Befestigungslochschrauben zu montieren, da dies sonst zu einem Installationsfehler führt!

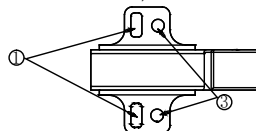

- ① Installez d'abord les vis du trou de réglage
 - ② Mettez la porte dans la bonne position
 - ③ Montieren Sie abschließend die Befestigungslochschrauben
- ① Install the adjustment hole screws first
 - ② Get the door in the right position
 - ③ Finally, install the fixing hole screws

- ① Montieren Sie zuerst die Einstellochsrauben
- ② Bringen Sie die Tür in die richtige Position
- ③ Enfin, installez les vis du trou de fixation

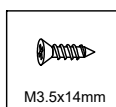
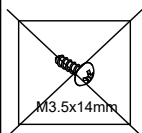

Step 22 Schritt 22



M3.5x14mm

Ⓜ x8pcs



Ⓛ x8pcs

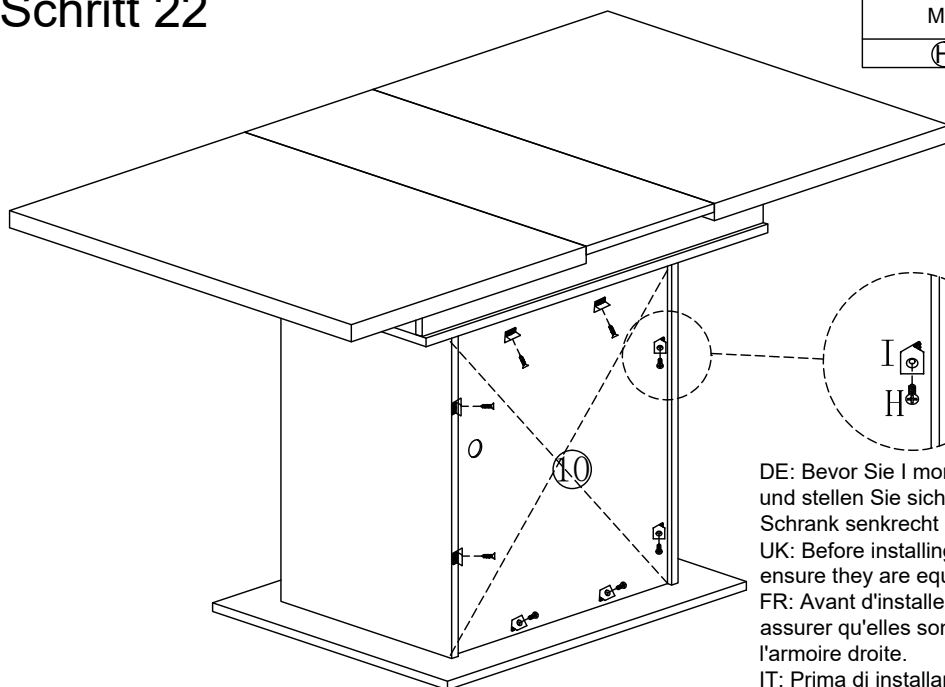

DE: Bevor Sie I montieren, messen Sie bitte die Diagonalen und stellen Sie sicher, dass sie gleich lang sind, um den Schrank senkrecht auszurichten.

UK: Before installing I, please measure the diagonals to ensure they are equal in length, keeping the cabinet upright.

FR: Avant d'installer I, veuillez mesurer les diagonales et vous assurer qu'elles sont de même longueur afin de maintenir l'armoire droite.

IT: Prima di installare I, misurare le diagonali e assicurarsi che siano della stessa lunghezza per mantenere l'armadio in posizione verticale.

ES: Antes de instalar I, mida las diagonales y asegúrese de que tengan la misma longitud para mantener el armario en posición vertical.

NL: Voordat u I installeert, meet de diagonalen en zorg ervoor dat ze even lang zijn om de kast rechtop te houden.

SE: Innan du installerar I, mät diagonalerna och se till att de är lika långa för att hålla skåpet upprätt.

PL: Przed zamontowaniem I zmierz przekątne i upewnij się, że są równej długości, aby szafa była pionowa.

Step 23 Schritt 23

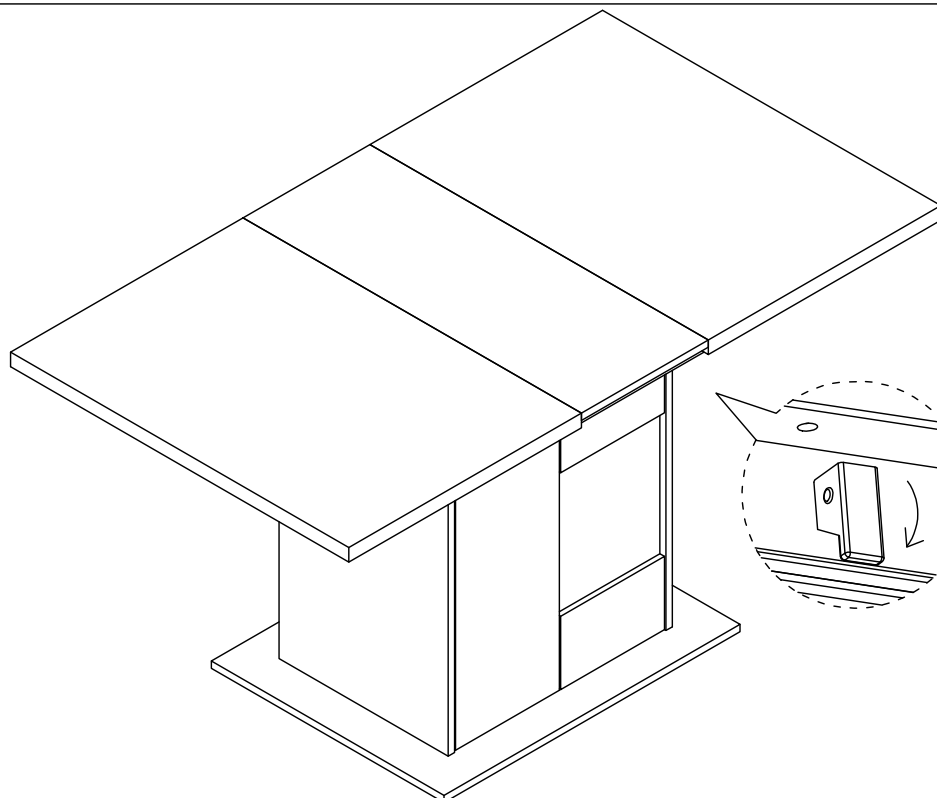

Step 24-1
Schritt 24-1

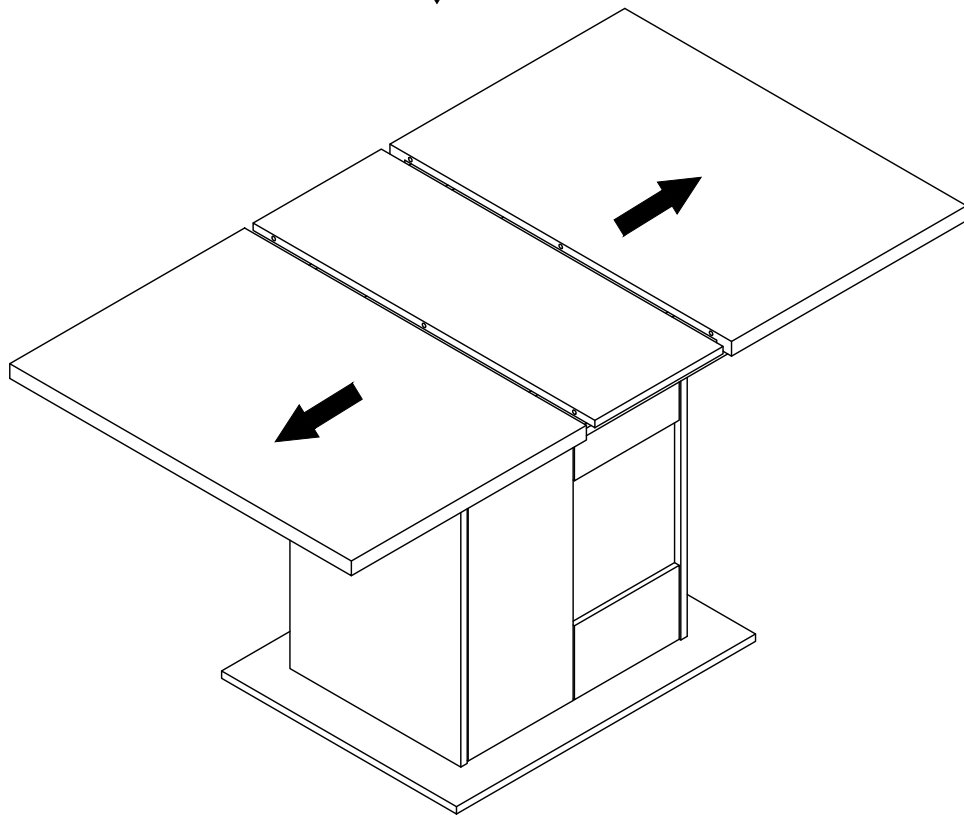
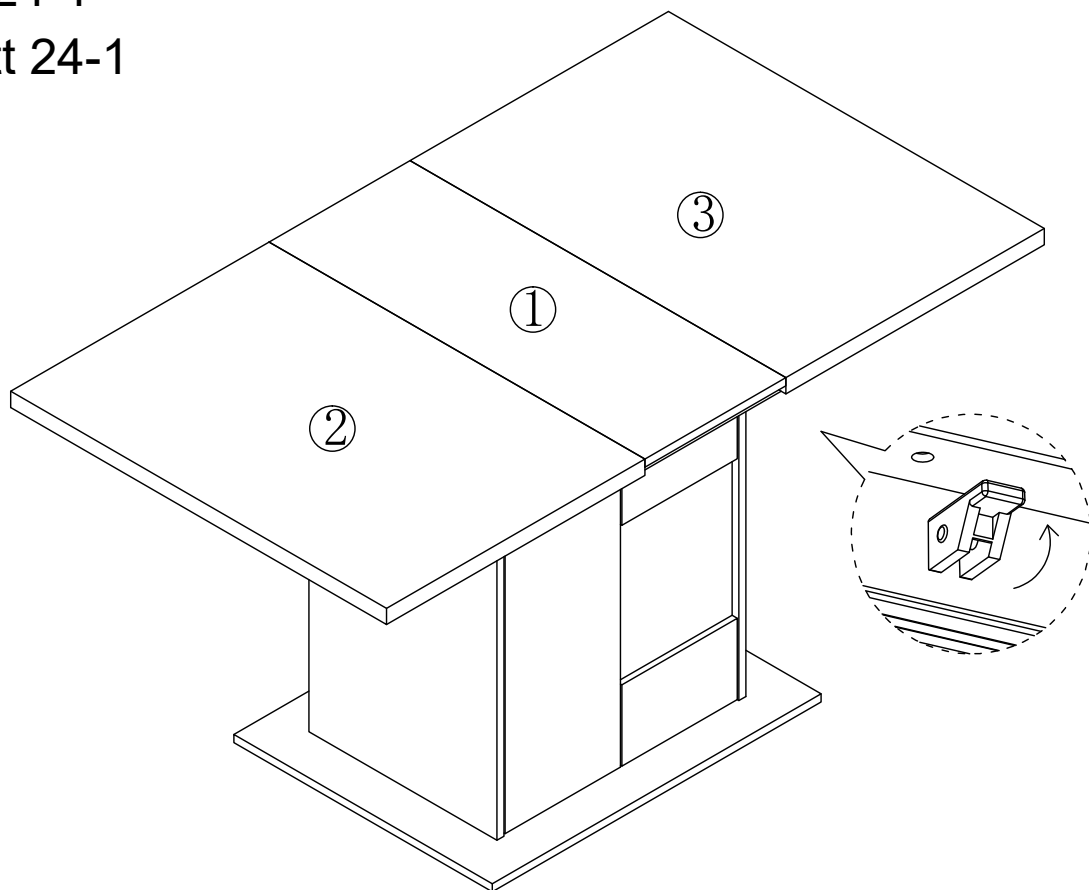

Step 24-2
Schritt 24-2

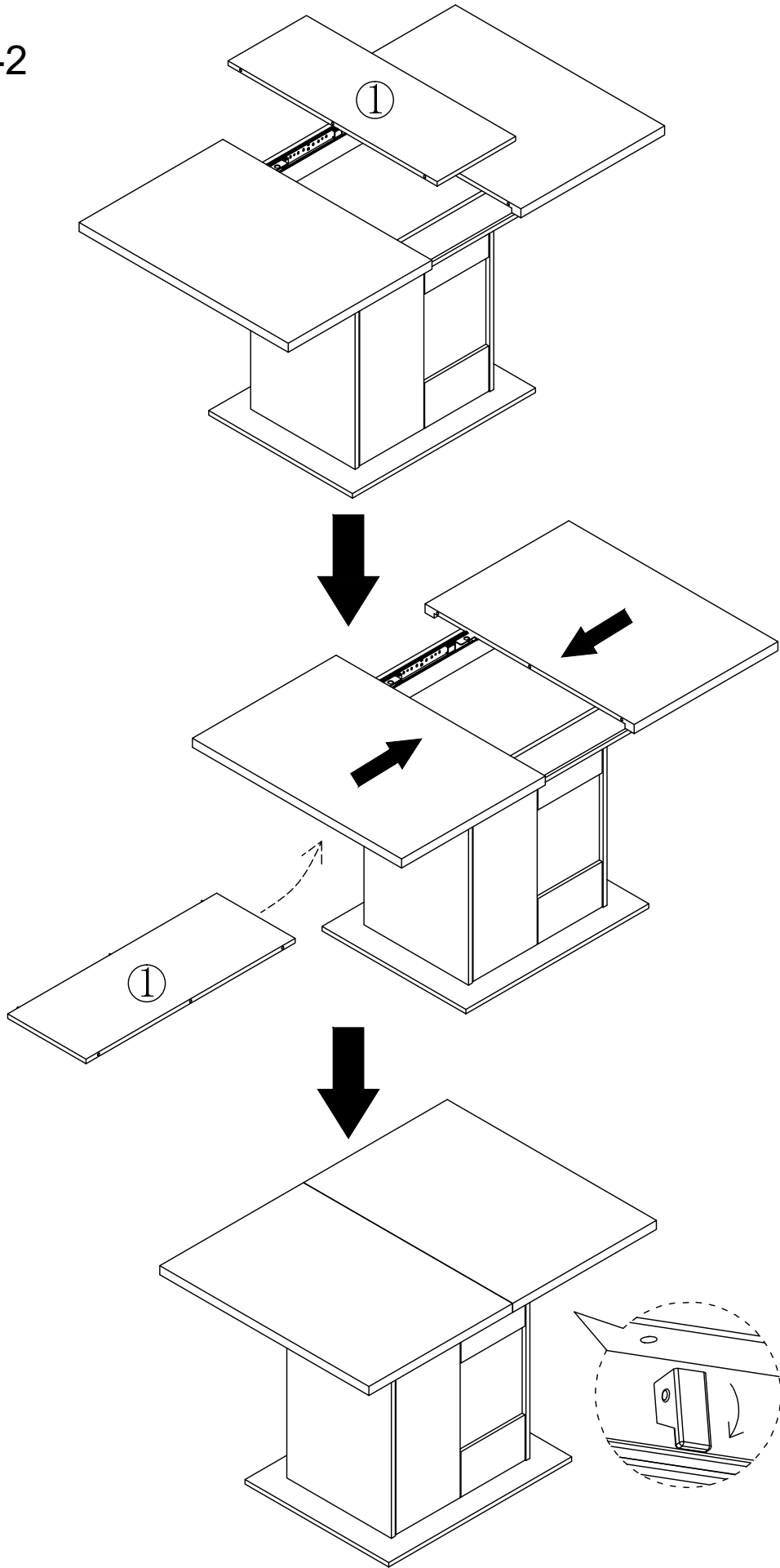

Step 25-1
Schritt 25-1

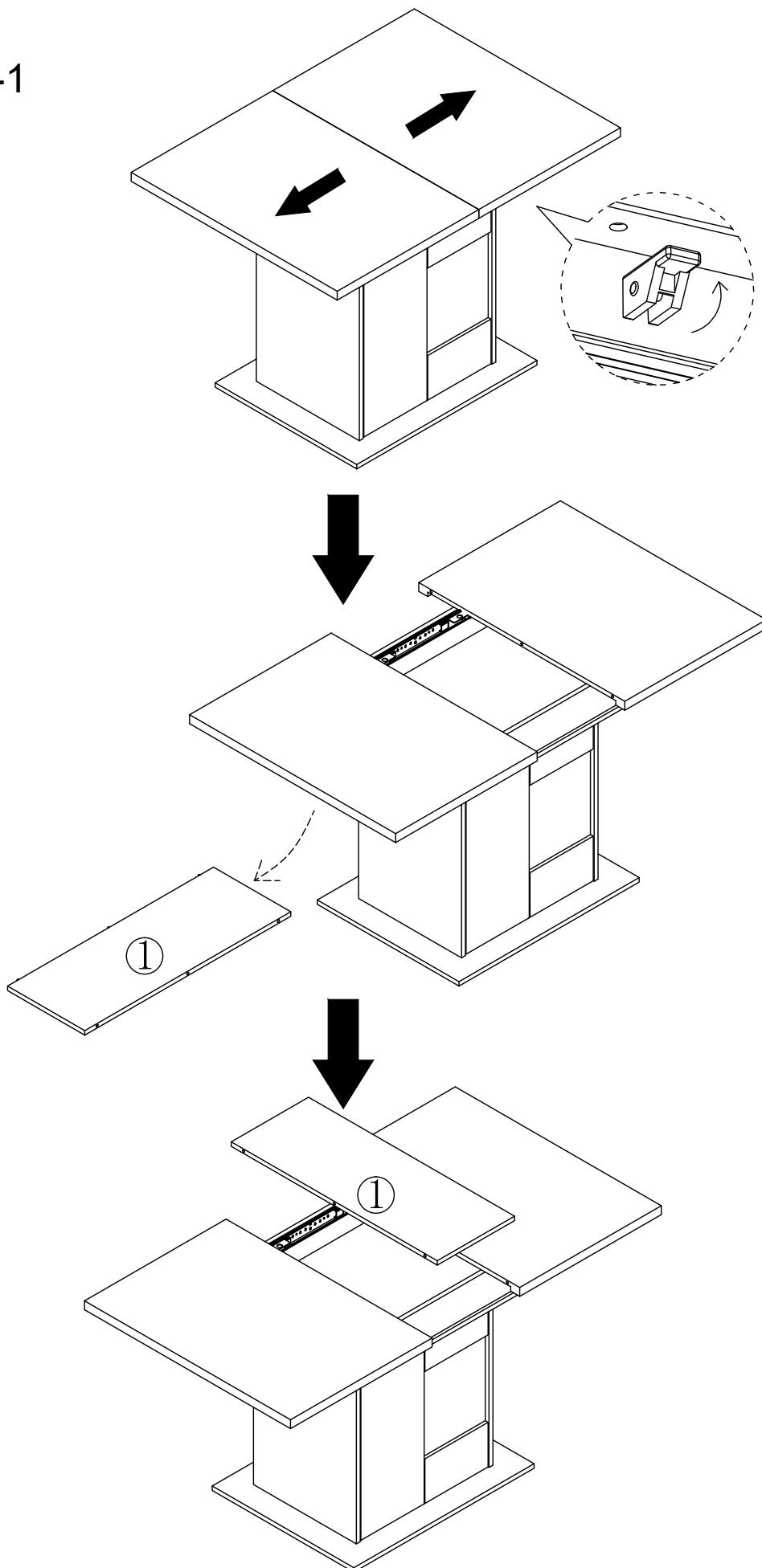

Step 25-2
Schritt 25-2

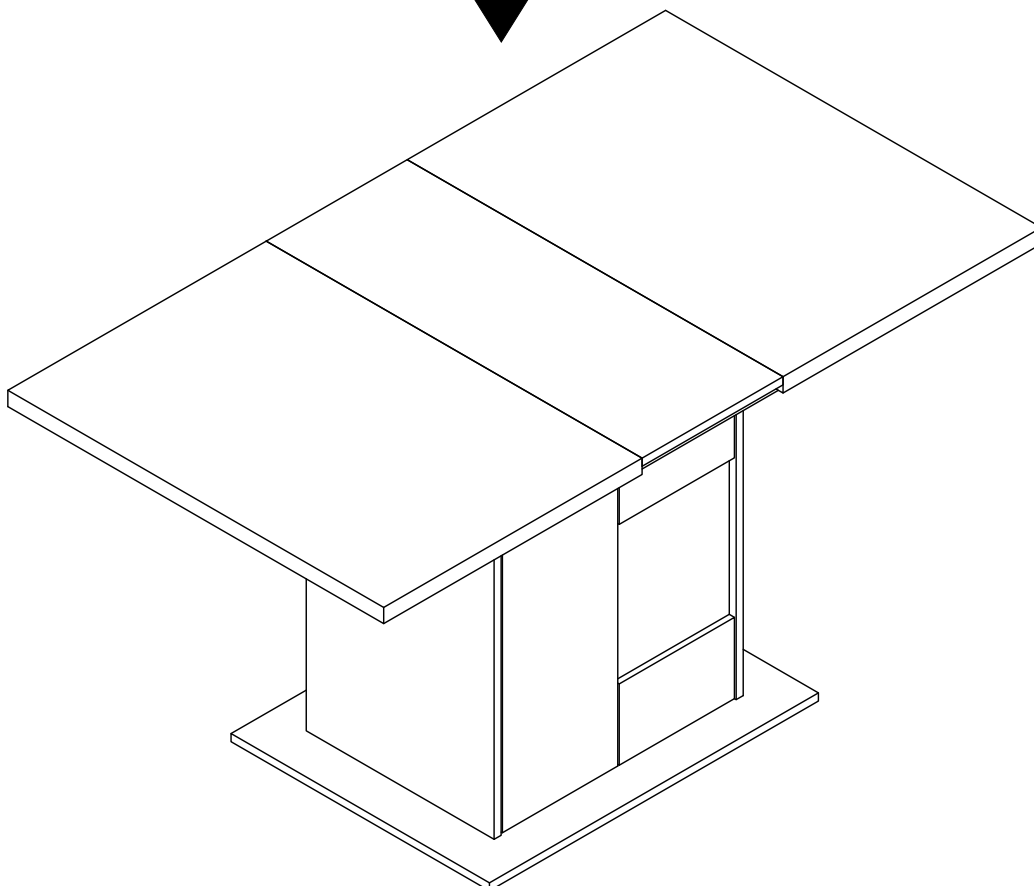
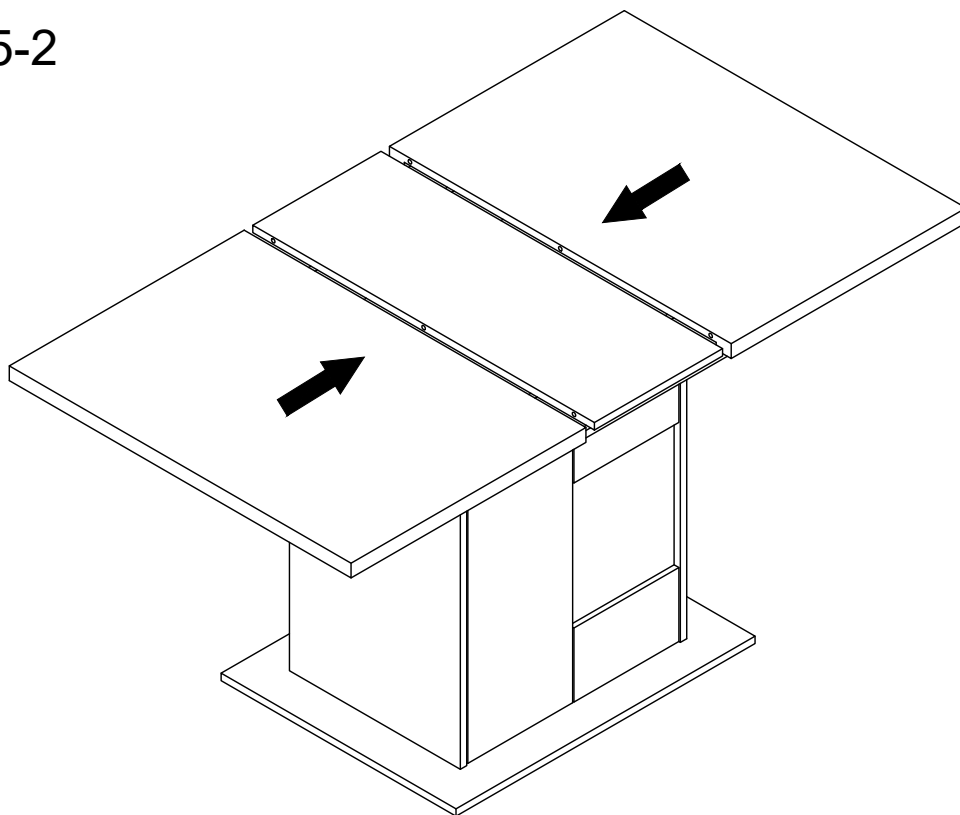

**(DE):**

1. Die maximale Tragfähigkeit des Produkts beträgt 60 kg, bitte nicht überladen.
2. Lassen Sie Kinder nicht auf Möbel klettern, da dies Umkippen und schwere Verletzungen verursachen kann.
3. Um die Sicherheit zu gewährleisten, installieren Sie bitte gemäß der Anleitung und ziehen Sie bei Bedarf Fachleute zurate.
4. Stellen Sie Möbel nicht in die Nähe von Feuerquellen oder heißen Gegenständen, um das Brandrisiko zu vermeiden.
5. Stellen Sie Möbel nicht in feuchten Umgebungen auf, um Materialschäden zu verhindern.
6. Überprüfen Sie regelmäßig alle Verbindungen und Befestigungen, um sicherzustellen, dass sie fest sind, um Unfälle zu vermeiden.
7. Reinigen Sie Möbel mit einem feuchten Tuch oder Alkohol, vermeiden Sie die Verwendung von reinigenden Mitteln mit ätzenden Chemikalien.

(UK):

1. The maximum weight capacity of the product is 60kg; do not overload.
2. Do not allow children to climb on furniture, as it may cause tipping and serious injury.
3. For safety, please install correctly according to the instructions, and seek professional assistance if necessary.
4. Do not place furniture near fire sources or hot items to avoid fire risk.
5. Do not place furniture in damp environments to prevent material damage.
6. Regularly check all connections and fasteners to ensure they are secure to prevent accidents.
7. Clean furniture with a damp cloth or alcohol; avoid using cleaners with corrosive chemicals.

(FR):

1. La capacité maximale de charge du produit est de 60 kg, ne pas surcharger.
2. Ne laissez pas les enfants grimper sur les meubles, cela peut entraîner un basculement et des blessures graves.
3. Pour garantir la sécurité, veuillez installer correctement selon les instructions et demander de l'aide à des professionnels si nécessaire.
4. Ne placez pas les meubles près de sources de chaleur ou d'objets chauds pour éviter les risques d'incendie.
5. Ne placez pas les meubles dans des environnements humides pour éviter d'endommager les matériaux.
6. Vérifiez régulièrement tous les raccords et fixations pour vous assurer qu'ils sont sécurisés afin d'éviter les accidents.
7. Nettoyez les meubles avec un chiffon humide ou de l'alcool, évitez d'utiliser des nettoyants contenant des produits chimiques corrosifs.

(IT):

1. La capacità massima del prodotto è di 60 kg, non sovraccaricare.
2. Non permettere ai bambini di arrampicarsi sui mobili, poiché ciò potrebbe causare ribaltamenti e gravi infortuni.
3. Per garantire la sicurezza, installare correttamente secondo le istruzioni e chiedere assistenza a professionisti se necessario.
4. Non posizionare i mobili vicino a fonti di calore o oggetti caldi per evitare rischi di incendio.
5. Non posizionare i mobili in ambienti umidi per prevenire danni ai materiali.
6. Controllare regolarmente tutte le connessioni e le viti per assicurarsi che siano sicure e prevenire incidenti.
7. Pulire i mobili con un panno umido o alcol; evitare di utilizzare detersivi contenenti sostanze chimiche corrosive.

(ES):

1. La capacidad máxima del producto es de 60 kg, no sobrecargar.
2. No permita que los niños escalen los muebles, ya que puede provocar vuelcos y lesiones graves.
3. Para garantizar la seguridad, instale correctamente según las instrucciones y busque asistencia profesional si es necesario.
4. No coloque muebles cerca de fuentes de fuego u objetos calientes para evitar riesgos de incendio.
5. No coloque muebles en ambientes húmedos para evitar daños en los materiales.
6. Revise regularmente todas las conexiones y sujetadores para asegurarse de que estén firmes y prevenir accidentes.
7. Limpie los muebles con un paño húmedo o alcohol; evite usar limpiadores con productos químicos corrosivos.

(NL):

1. De maximale draagcapaciteit van het product is 60 kg; niet overbelasten.
2. Laat kinderen niet op meubels klimmen, dit kan omvallen en ernstige verwondingen veroorzaken.
3. Installeer correct volgens de instructies voor de veiligheid en vraag indien nodig om professionele hulp.
4. Plaats meubels niet in de buurt van vuurbronnen of hete voorwerpen om brandrisico te voorkomen.
5. Plaats meubels niet in vochtige omgevingen om materiaalschade te voorkomen.
6. Controleer regelmatig alle verbindingen en bevestigingen om ervoor te zorgen dat ze stevig zijn en ongelukken te voorkomen.
7. Maak meubels schoon met een vochtige doek of alcohol; vermijd het gebruik van schoonmaakmiddelen met bijtende chemicaliën.

(SE):

1. Den maximala belastningen för produkten är 60 kg; överbelasta inte.
2. Låt inte barn klättra på möbler, eftersom det kan leda till att de tippar och orsakar allvarliga skador.
3. För att säkerställa säkerheten, installera korrekt enligt instruktionerna och be om professionell hjälp vid behov.
4. Placera inte möbler nära värmekällor eller heta föremål för att undvika brandrisk.
5. Placera inte möbler i fuktiga miljöer för att förhindra materialskador.
6. Kontrollera regelbundet alla anslutningar och fästen för att säkerställa att de är säkra för att förhindra olyckor.
7. Rengör möbler med en fuktig trasa eller alkohol; undvik att använda rengöringsmedel med frätande kemikalier.

(PL):

1. Maksymalne obciążenie produktu wynosi 60 kg; nie przeciążaj.
2. Nie pozwalaj dzieciom wspinać się na meble, ponieważ może to prowadzić do przewrócenia i poważnych obrażeń.
3. Aby zapewnić bezpieczeństwo, zainstaluj poprawnie zgodnie z instrukcjami i w razie potrzeby skorzystaj z pomocy specjalistów.
4. Nie stawiaj mebli w pobliżu źródeł ognia lub gorących przedmiotów, aby uniknąć ryzyka pożaru.
5. Nie umieszczaj mebli w wilgotnym środowisku, aby zapobiec uszkodzeniu materiałów.
6. Regularnie sprawdzaj wszystkie połączenia i mocowania, aby upewnić się, że są solidne, aby zapobiec wypadkom.
7. Czyść meble wilgotną szmatką lub alkoholem; unikaj używania środków czyszczących z żrącymi chemikaliami.