

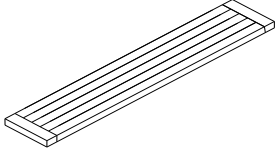

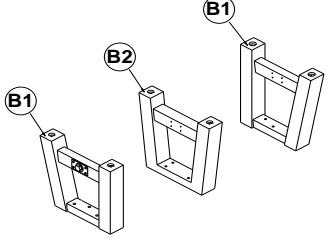

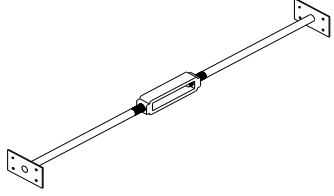

ASSEMBLY INSTRUCTIONS

PARTS LIST

A	BENCH TOP X 1			<p>Before beginning</p> <p>1 - Carefully unpack and position the item on a clean, non-marring surface to assemble.</p> <p>2 - Read this Assembly Instructions from beginning to end before starting to assemble.</p> <p>3 - Take an inventory of the required parts to ensure all are available.</p> <p>4 - To prevent accidental choking hazards, keep all packing materials away from small children.</p> <p>5 - Only tighten hardware until ALL hardware are fully engaged on their locations. Overtighten bolts will damage the bolt threads.</p> <p>6 - Use only factory provided hardware to assemble. Unapproved hardware can damage product or jeopardize the structural integrity of the product.</p> <p>7 - The use of power tool to assemble is not recommended due to high risk of over-torque, which can damage the product.</p>						
B	LEG X 3									
D	METAL X 2									
Z	HARDWARE	<p>Z1</p>  <p>8 X 70MM X 10</p>	<p>Z2</p>  <p>8 X 19 X 2MM X 10</p>	<p>Z3</p>  <p>8 X 12 X 2MM X 10</p>	<p>Z4</p>  <p>Open Wrench X 1</p>	<p>Z5</p>  <p>4 X 20MM X 16</p>	<p>Z6</p>  <p>Screwdriver X 1</p>			

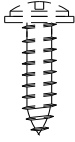

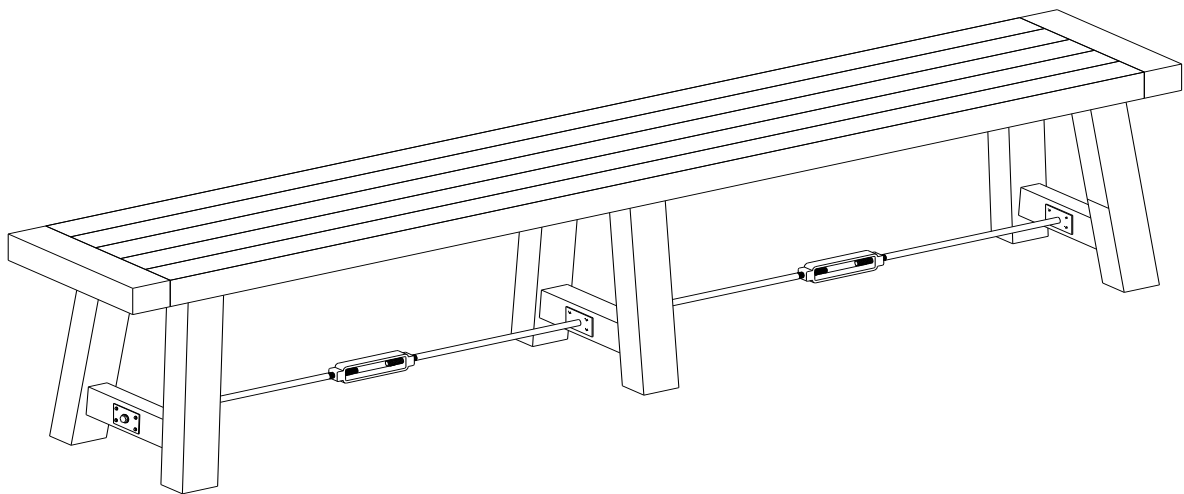
ASSEMBLY REQUIRES
TWO PEOPLE



15-MINUTE
ASSEMBLY TIME



KEEP INSTRUCTIONS
FOR FUTURE USE



ASSEMBLY INSTRUCTIONS

1

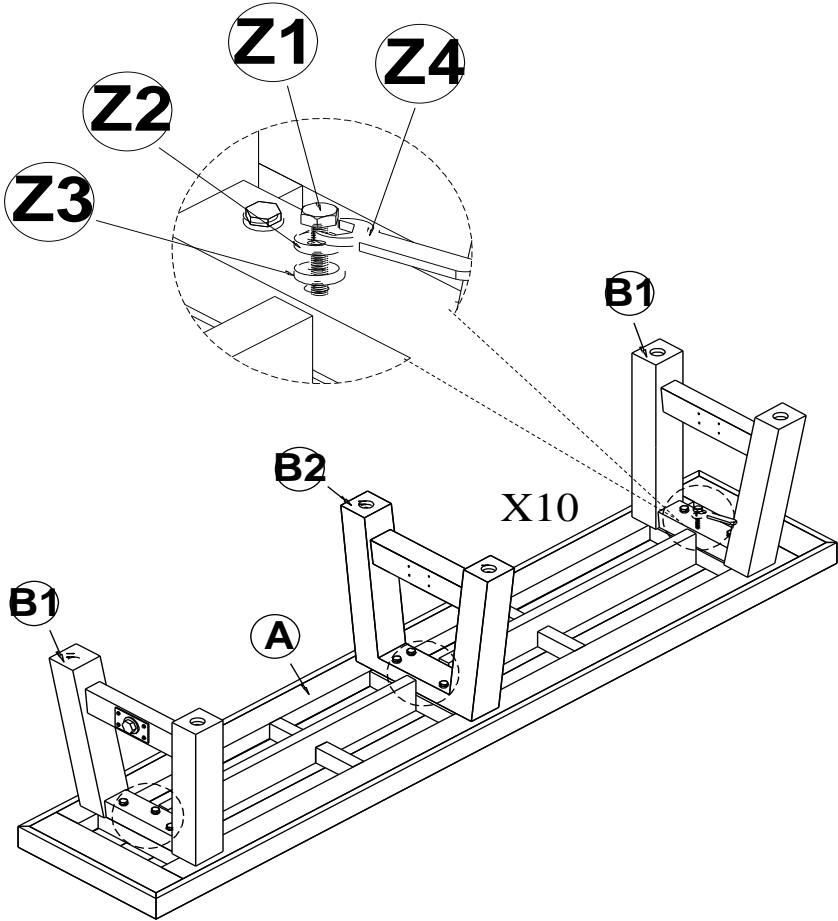

- Assemble the Legs (B) into the Bench Top (A) as pictured. Using Open Wrench (Z4) to tighten Bolts (Z1), Spring washer (Z2) and Washers (Z3).

2

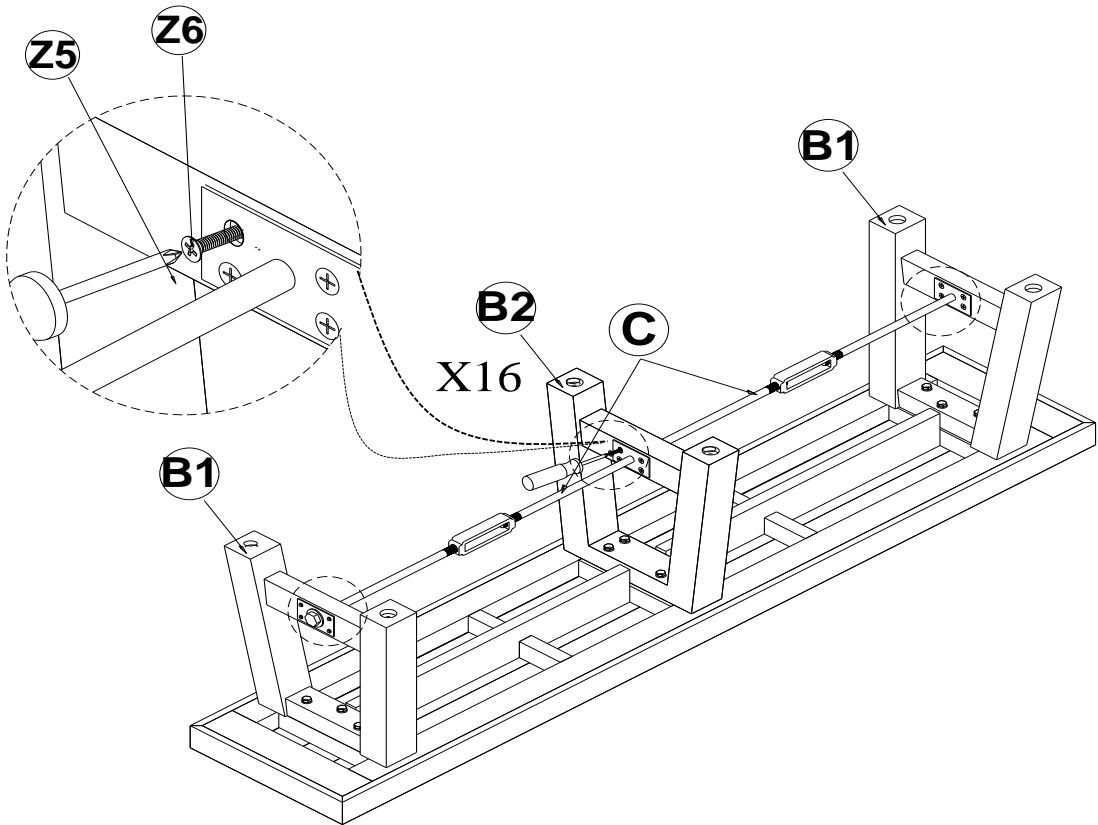

- Assemble the Metal Struts (C) to the Legs (B) as pictured. Tighten all Screw Bolts (Z5) by Screwdriver (Z6).

ASSEMBLY INSTRUCTIONS

1

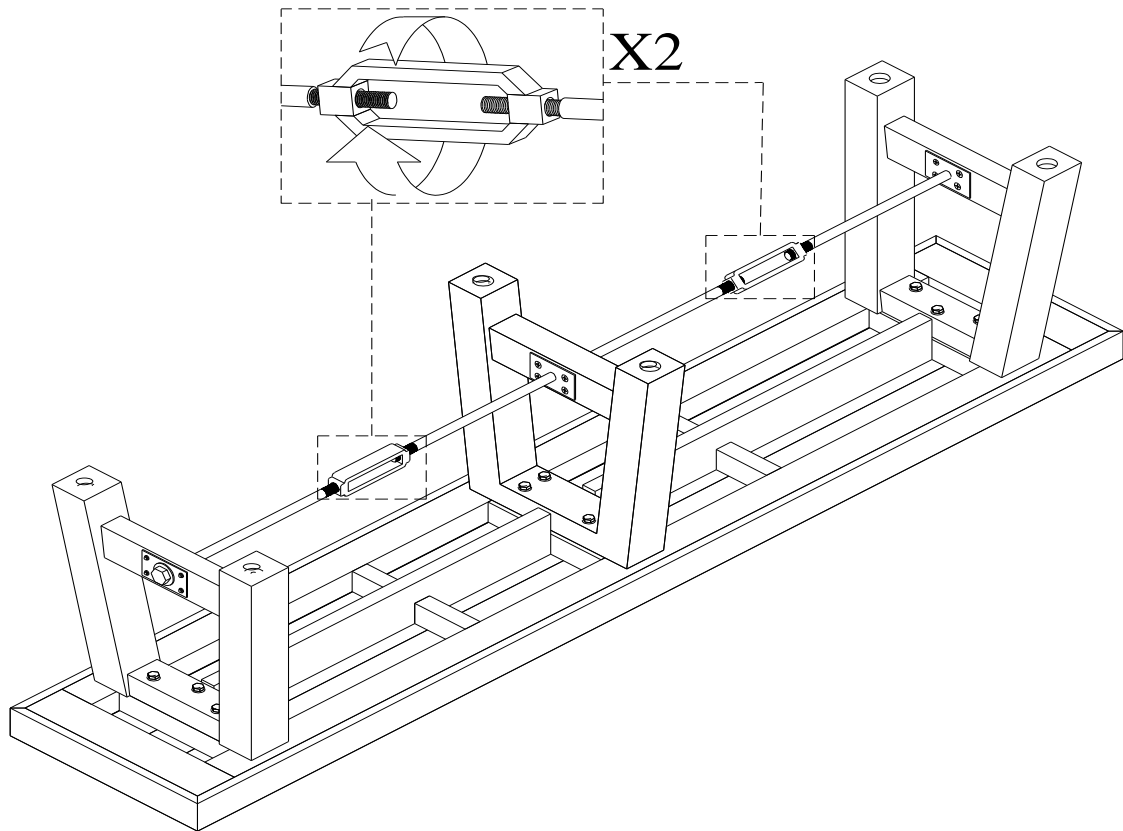

- Adjust the Turnbuckles of Metal Struts (C).

2

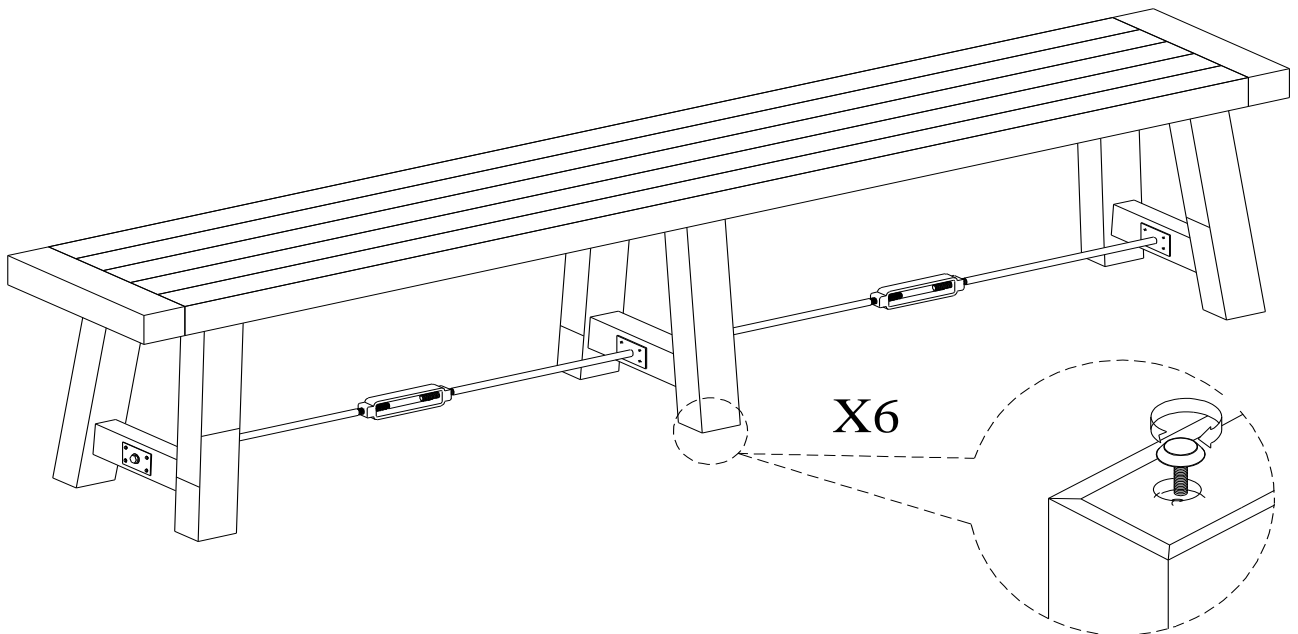

- With two people carefully turn the bench over and stand on its legs.
- If the bench doesn't sit level, please adjust the adjustable levelers under the legs.
- Completed item.