

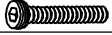







# ASSEMBLY INSTRUCTIONS

Don't tighten any hardware until all hardware on a step have been started

Thank you for purchasing this quality product. Be sure to check all packing material carefully for small parts, which may have come loose inside the carton during shipment. Identify and count all parts and compare with the HARDWARE LIST below.

NO	PARTS LIST	Qty.	NO	HARDWARE LIST	Qty.
A	Bonded leather seat	1PC	1		8PCS
	Top ring		2		8PCS
B	Metal swivel	1PC	3		8PCS
	Middle ring		4		1PC
C	Bottom ring	1PC	5		8PCS
D	Leg	4PCS	6		8PCS
			7		8PCS
			8		1PC

## STEP 1

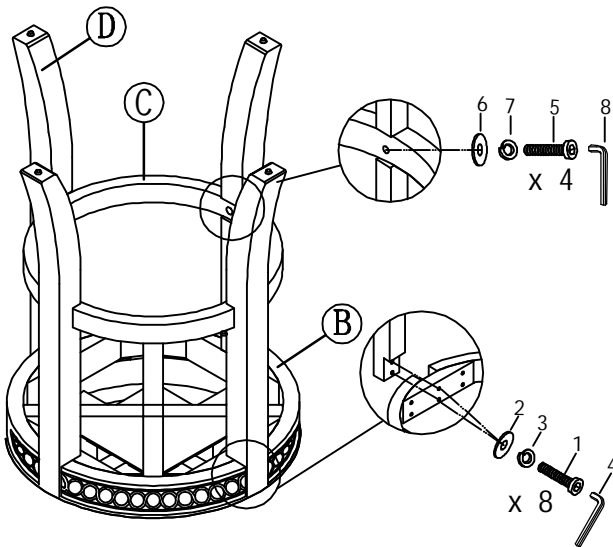

1. Attach the four Legs(D) to the Middle Ring(B), using an Allen wrench and hardware(4+1+3+2) to tighten, as shown (Swivel face down)
2. Attach the Bottom Ring(C) to the Legs, using an Allen wrench and hardware (8+5+7+6) to tighten, as shown

## STEP 2

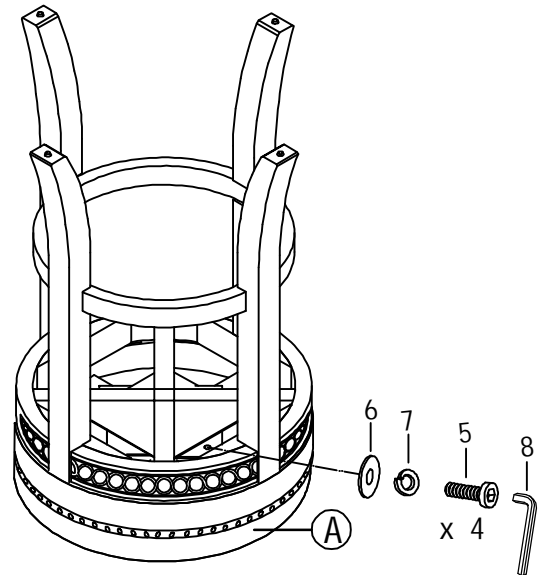

1. Upside down the Bonded leather seat (A) and put it on a smooth and stable working stand.
2. Attach the assembled Legs frame to the Seat w/top ring(A), using an Allen wrench and hardware(8+5+7+6) to tighten, as shown.

## STEP 3

1. Right side up the stool.
2. It's complete for using.

Caution: 1: All hardware must be tightened mandatorily in each step.  
2: It is also mandatorily recommended to periodically check hardware and retighten as needed.

