

# ASSEMBLY INSTRUCTIONS

ITEM: WF309978

## Important note/Note importante:

1. Place all wooden parts on a clean and smooth surface such as a rug or carpet to avoid scratching the parts.
2. Kindly follow the assembly instructions step by step.
3. Do not tighten all screws and bolts until the table is fully assembled.
4. Unscrew the protective plastic supports from the metal insert of the table legs before assembly.

## PARTS IDENTIFICATION

**A** Table Top

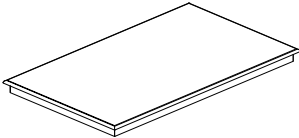

1 pc

**B** Connect Panel

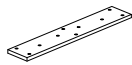

2 pcs

**C** Leg Frame

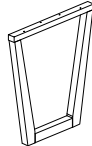

2 pcs

**D** Leg Base

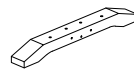

2 pcs

**E** Bottom Frame

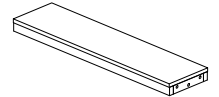

1 pc

## HARDWARE IDENTIFICATION

**1** Bolt  
Ø5/16" x 35mm



12 pcs

**2** Bolt  
Ø1/4" x 38mm



14 pcs

**3** Long Bolt  
Ø1/4" x 55mm

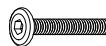

8 pcs

**4** Spring Washer  
Ø5/16" x 13mm



12 pcs

**5** Flat Washer  
Ø5/16" x 19mm



12 pcs

**6** Spring Washer  
Ø1/4" x 11mm



22 pcs

**7** Flat Washer  
Ø1/4" x 19mm



22 pcs

**8** Allen Key



1 pc

### STEP 1 Tighten all bolts.

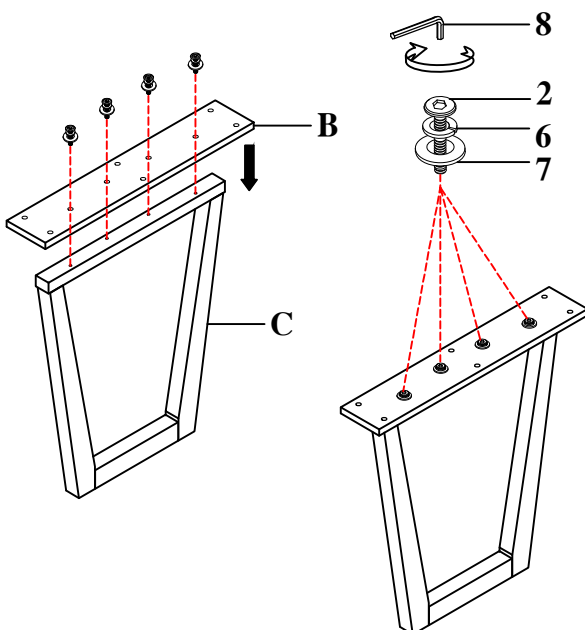

### STEP 2 Tighten all bolts.

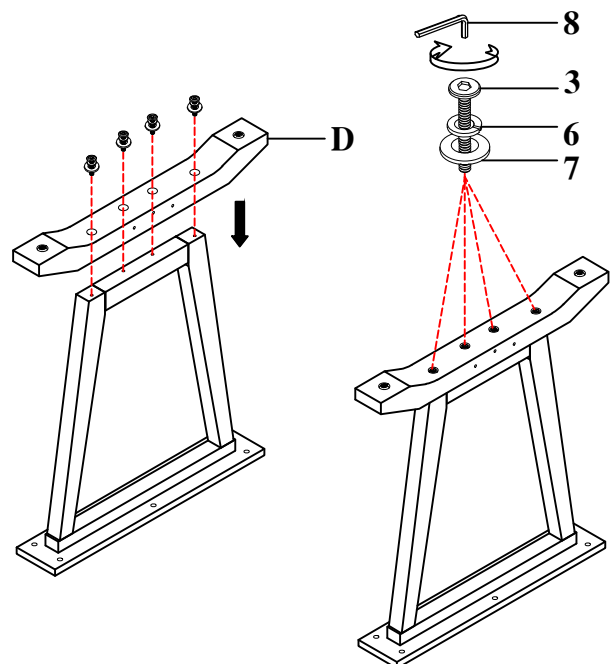

# ASSEMBLY INSTRUCTIONS

ITEM: WF309978

STEP 3

STEP 4

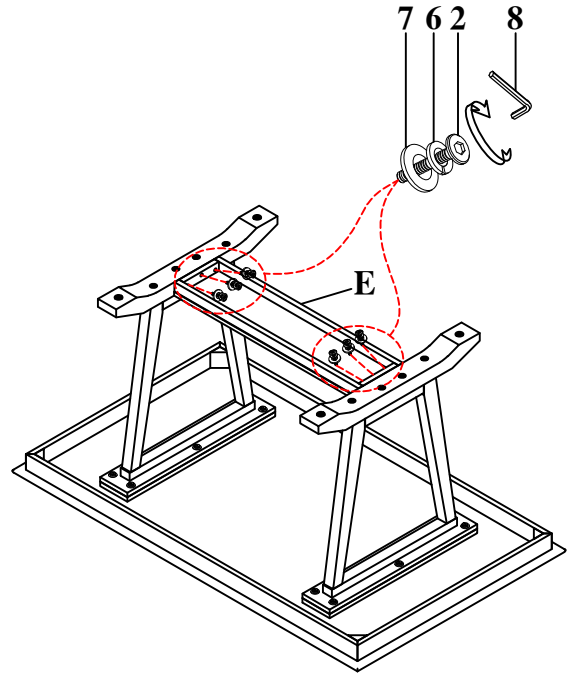
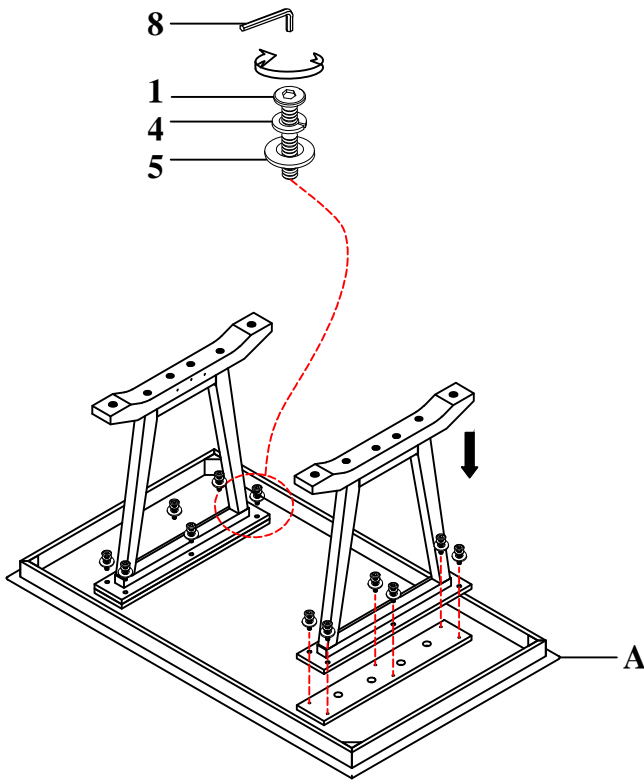

STEP 5

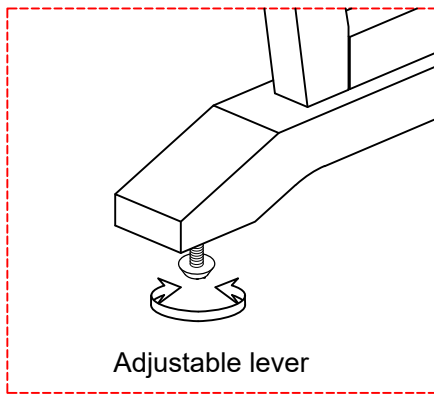

COMPLETE

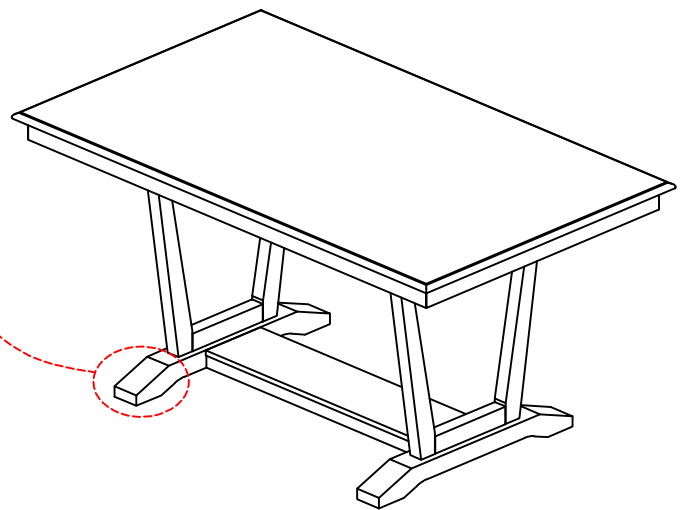

# ASSEMBLY INSTRUCTIONS

ITEM:WF309979

## Important note/Note importante:

1. Place all wooden parts on a clean and smooth surface such as a rug or carpet to avoid scratching the parts.
2. Kindly follow the assembly instructions step by step.
3. Do not tighten all screws and bolts until the table is fully assembled.

## PARTS IDENTIFICATION

### **A** Chair Back

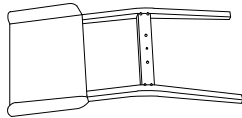

1 pc

### **B** Seat Frame

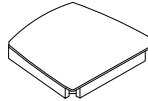

1 pc

### **C** Front Leg

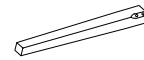

2 pcs

## HARDWARE IDENTIFICATION

### **1** Bolt

Ø1/4" x 80mm



4 pcs

### **2** Bolt

Ø1/4" x 55mm



4 pcs

### **3** Bolt

Ø1/4" x 38mm



1 pc

### **4** Spring Washer

Ø1/4" x 11mm



9 pcs

### **5** Flat Washer

Ø1/4" x 19mm



9 pcs

### **6** Allen Key

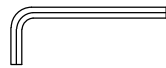

1 pc

## STEP 1

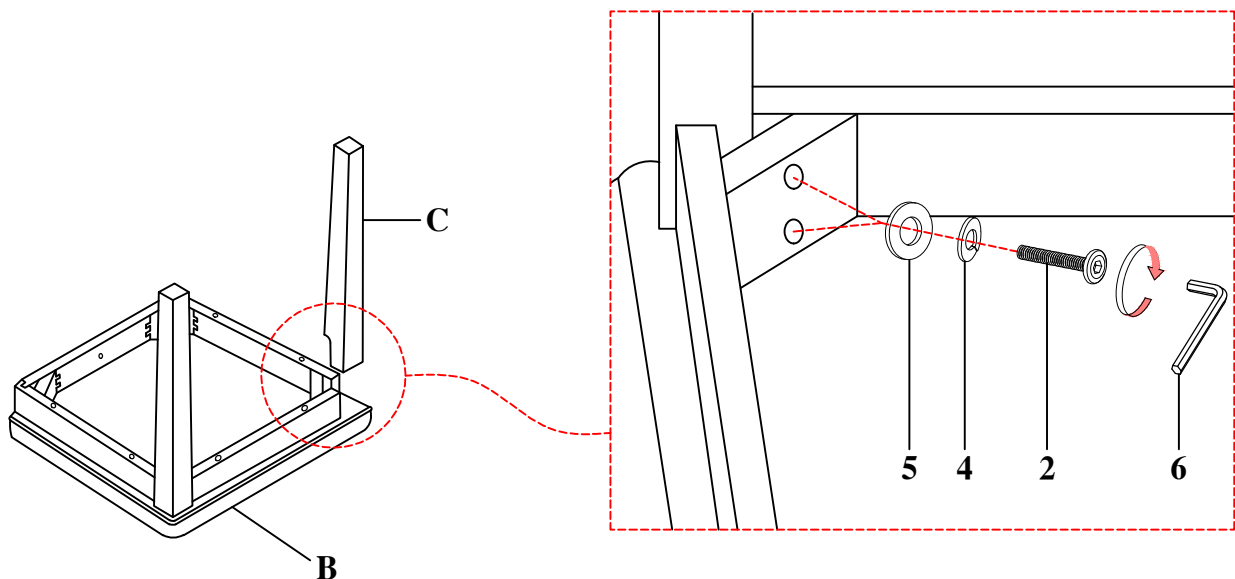

# ASSEMBLY INSTRUCTIONS

ITEM: WF309979

## STEP 2

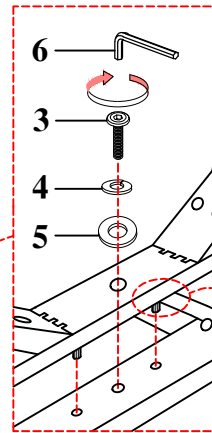
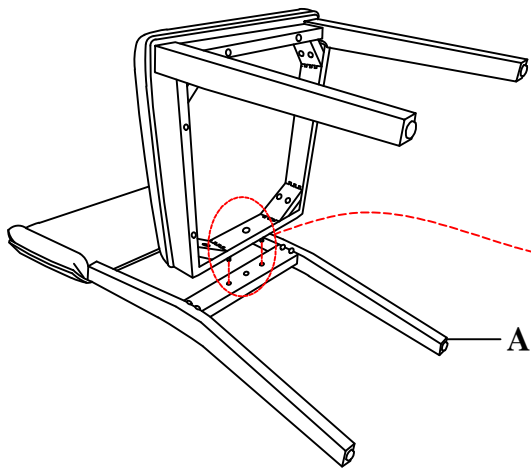

Wood dowel had fixed on the seat frame

## STEP 3

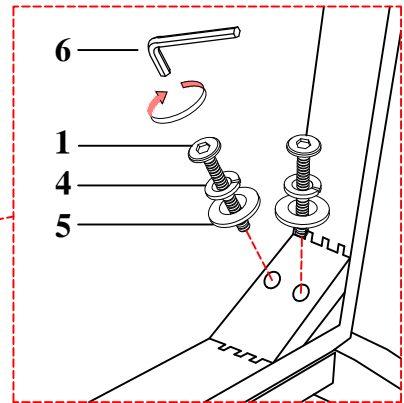
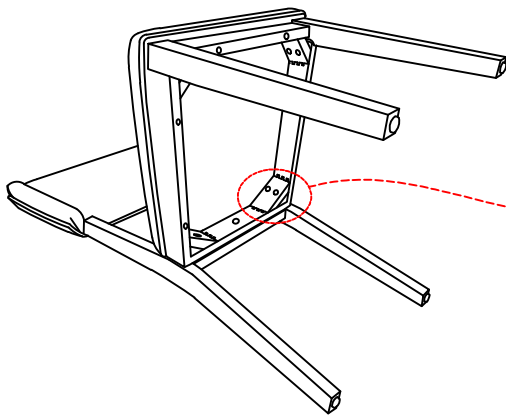

COMPLETE

