

# Assembly Instructions

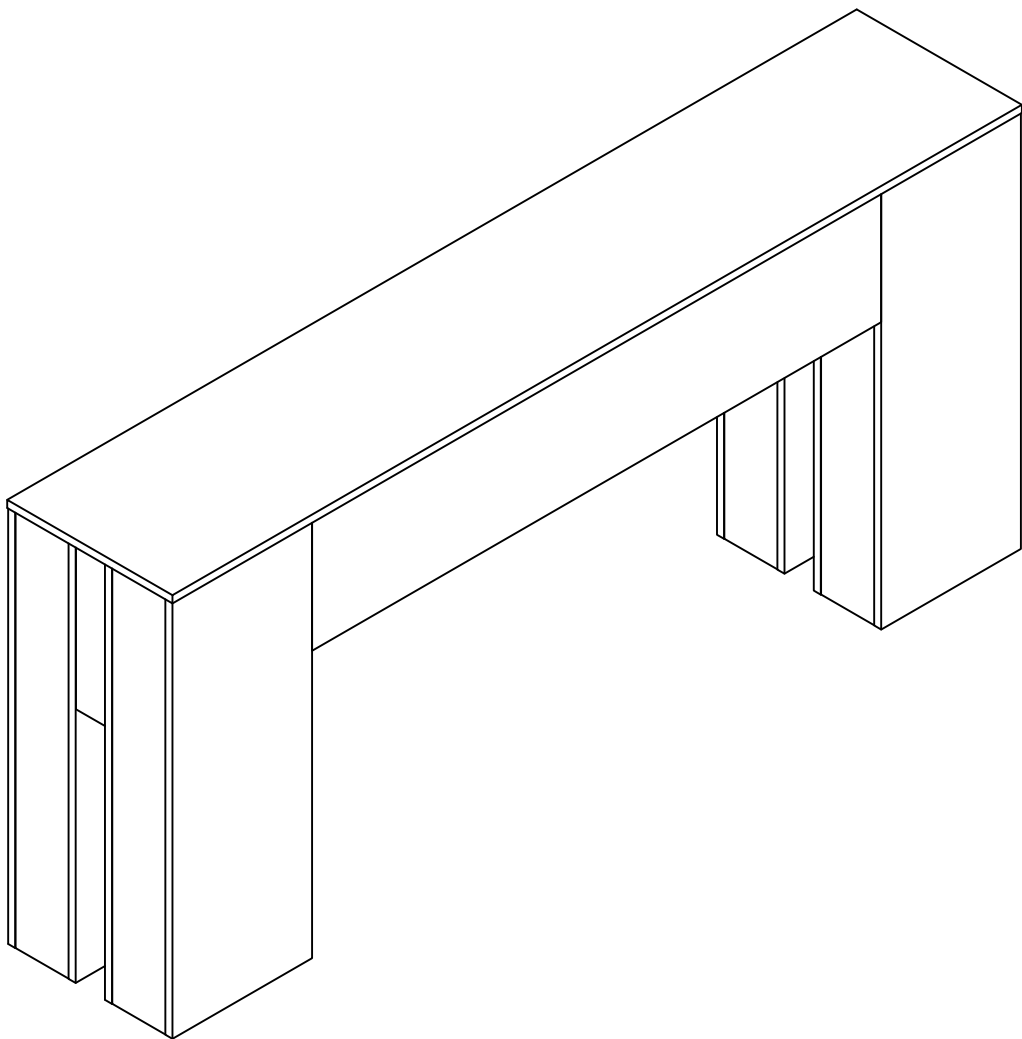

---

Console Table

Model No.  
HOGA-F2200/F2442  
HOGA-F2335/F2502

---

# Contact Us

## We're here to help you.



Your satisfaction is our top priority. If you encounter any issues with this product, such as missing or damaged parts, we're here to help. Please retain the original packaging and take photos of the packaging and the product, then contact us as soon as possible.

### Warm Tips

1. Carefully read these instructions and keep them for future reference.
2. Check the parts list and confirm everything's there before starting assembly.
3. When assembling, put all parts on a soft, smooth surface like a carpet to avoid scratches.
4. Don't fully tighten screws until all parts are confirmed in place to avoid misalignment.

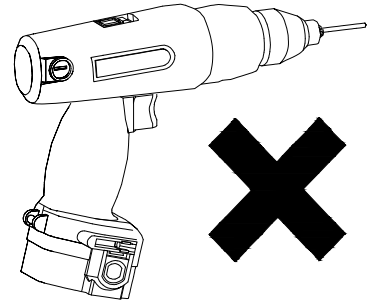
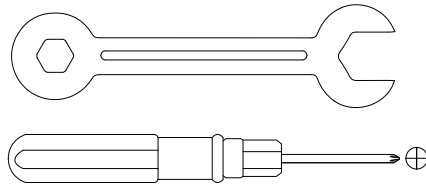
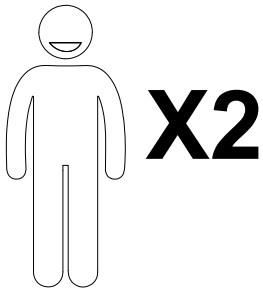

We recommend using hand tools for assembly.

If an electric screwdriver is used, reduce power and torque to avoid damage to the product.

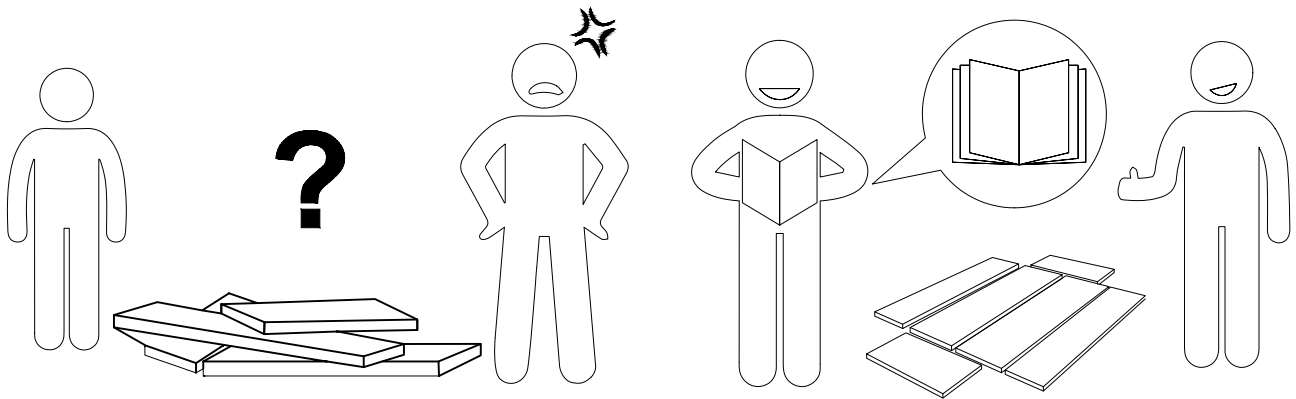

## Install the Anti-Tip Straps

Using the anti-tip straps can reduce the risk of tipping over, but can not eliminate it.

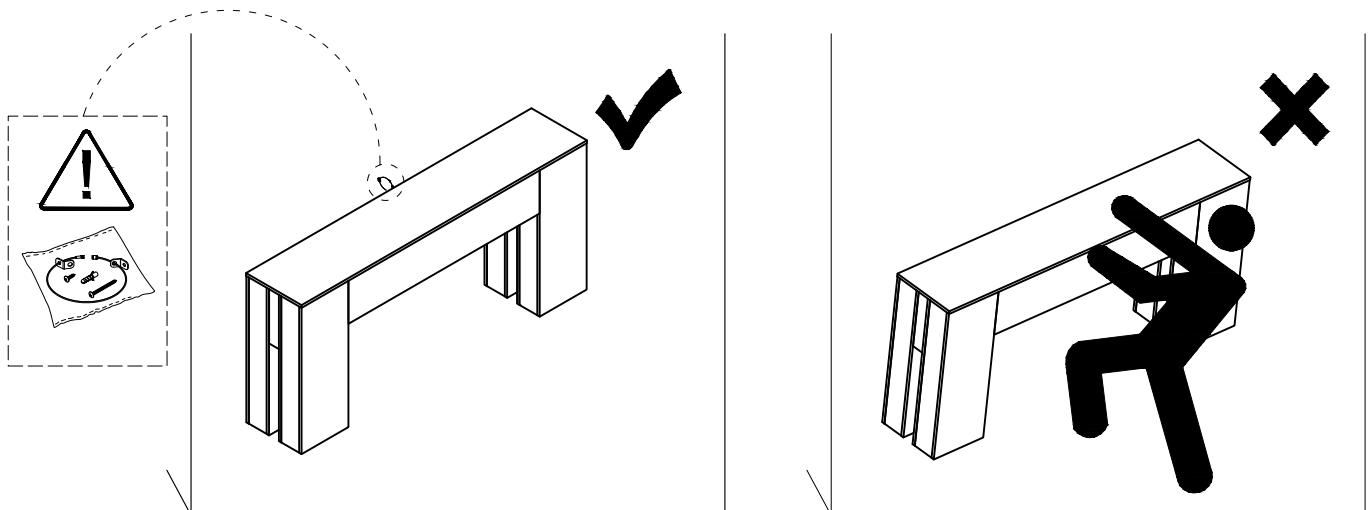

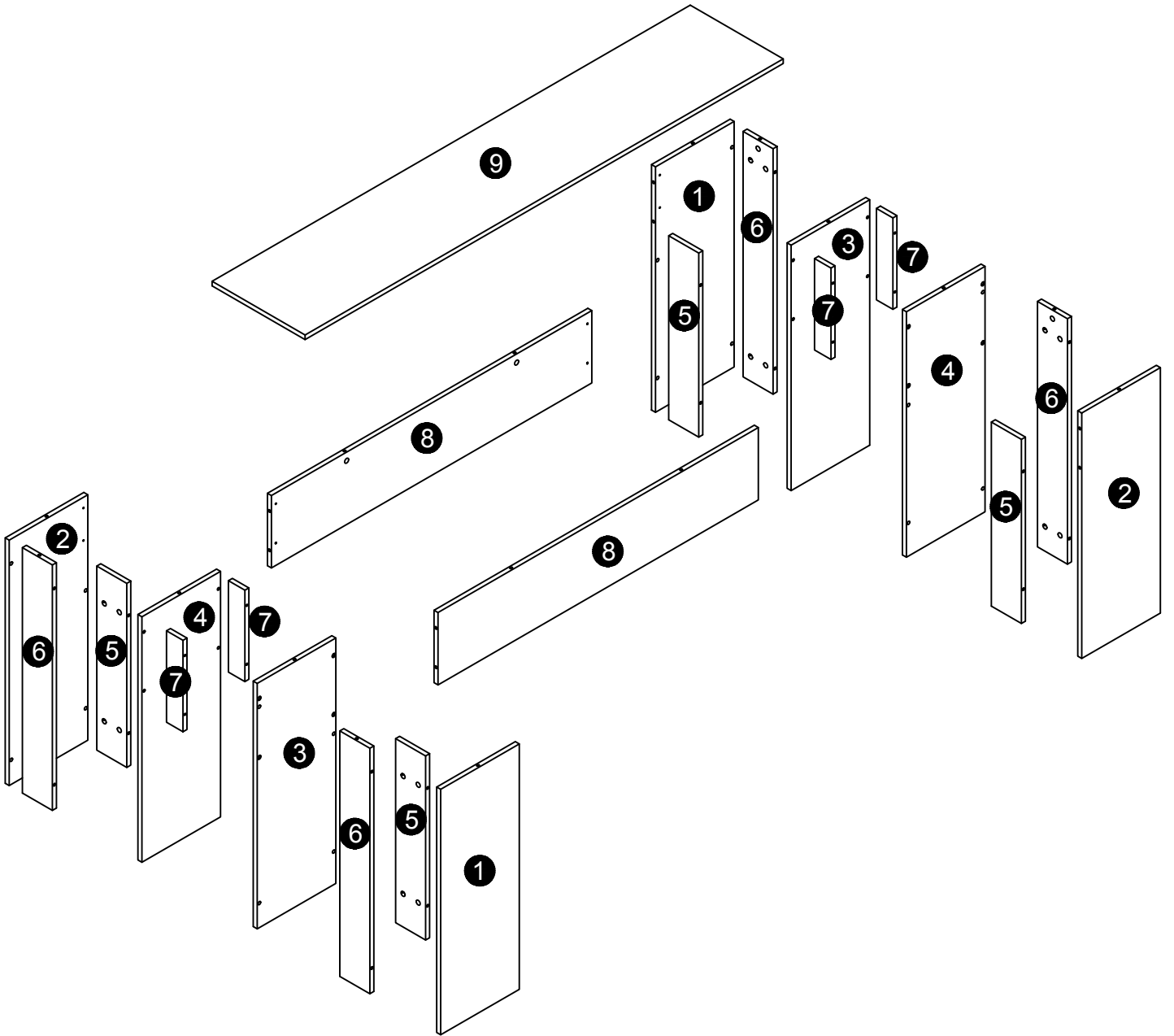



**⚠ Caution**

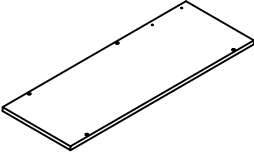
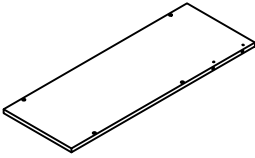
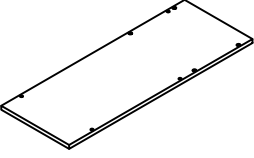
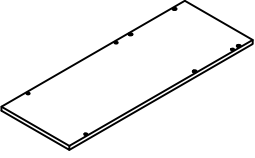
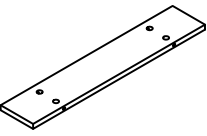
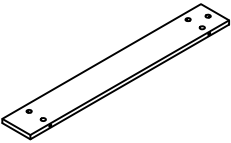
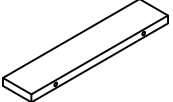
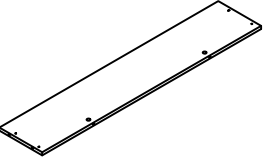
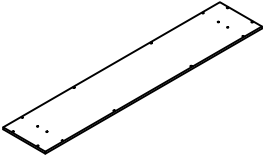

Make sure all parts are included. Most board parts are labeled or stamped on the raw edge. Contact us for a free replacement if you encounter any damaged or missing parts.

## Parts List

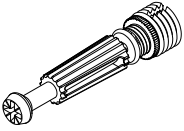
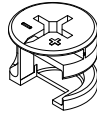
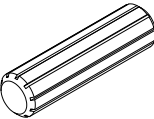
<p><b>1</b></p>  <p>2 pcs</p>	<p><b>2</b></p>  <p>2 pcs</p>	<p><b>3</b></p>  <p>2 pcs</p>	<p><b>4</b></p>  <p>2 pcs</p>	<p><b>5</b></p>  <p>4 pcs</p>
<p><b>6</b></p>  <p>4 pcs</p>	<p><b>7</b></p>  <p>4 pcs</p>	<p><b>8</b></p>  <p>2 pcs</p>	<p><b>9</b></p>  <p>1 pc</p>	

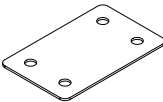
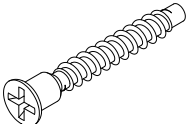
## Hardware List

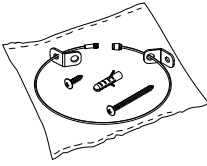
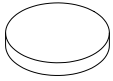
A	B	C	D	E	F
 <p>M6x35mm</p>	 <p>Ø15x12mm</p>	 <p>Ø8x30mm</p>	 <p>Ø3.5x14mm</p>	 <p>60x38mm</p>	 <p>Ø7x38mm</p>
40 pcs	40 pcs	16 pcs	32 pcs	8 pcs	16 pcs

G	H				
	 <p>Ø16x3mm</p>				
1 pc	16 pcs	1 pc			

# Installation of Cams and Pins

Step 1-2: Align the plastic part with the mounting hole and press it in. If you can't press it in, loosen the screw counter clockwise or completely remove the screw from the plastic part and try again.  
Step 3-4: After pressing the plastic part into place, use a screwdriver to tighten the screw clockwise.

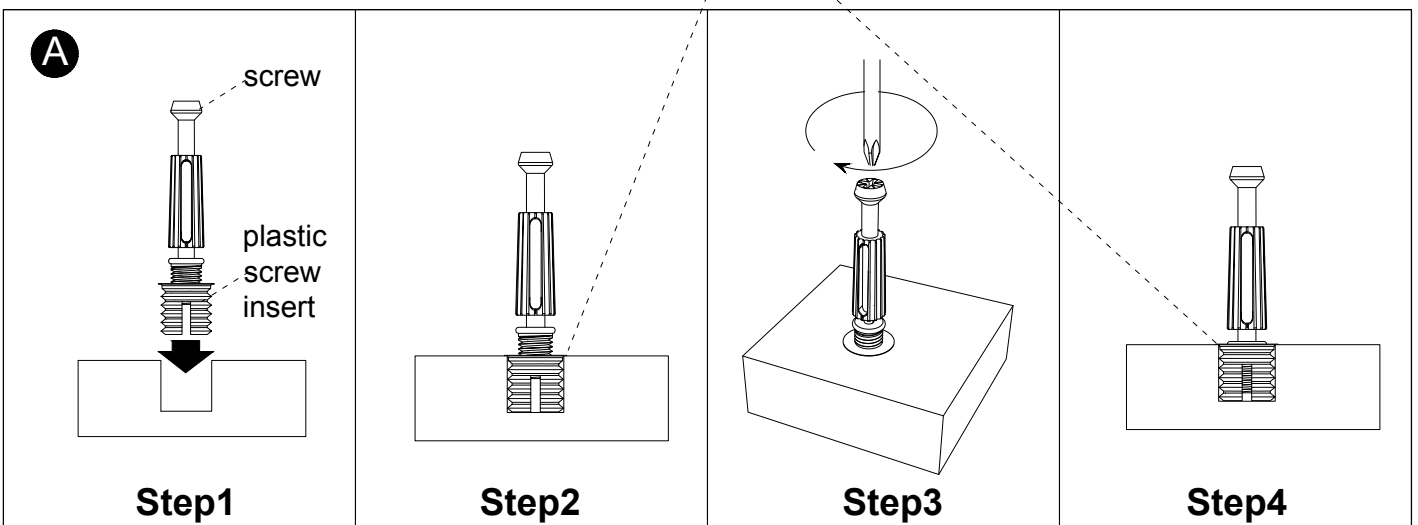
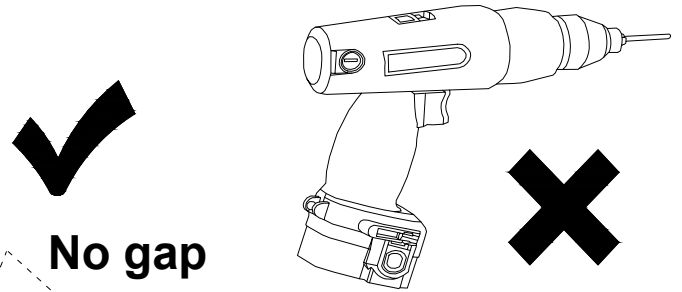

Screw the pin into the hole. Set the cams correctly by aligning the head of the cams with the lock pins. Lock the cam by turning the cam head with a screwdriver until it is tightened. Please do not use an electric screwdriver to assemble the unit.

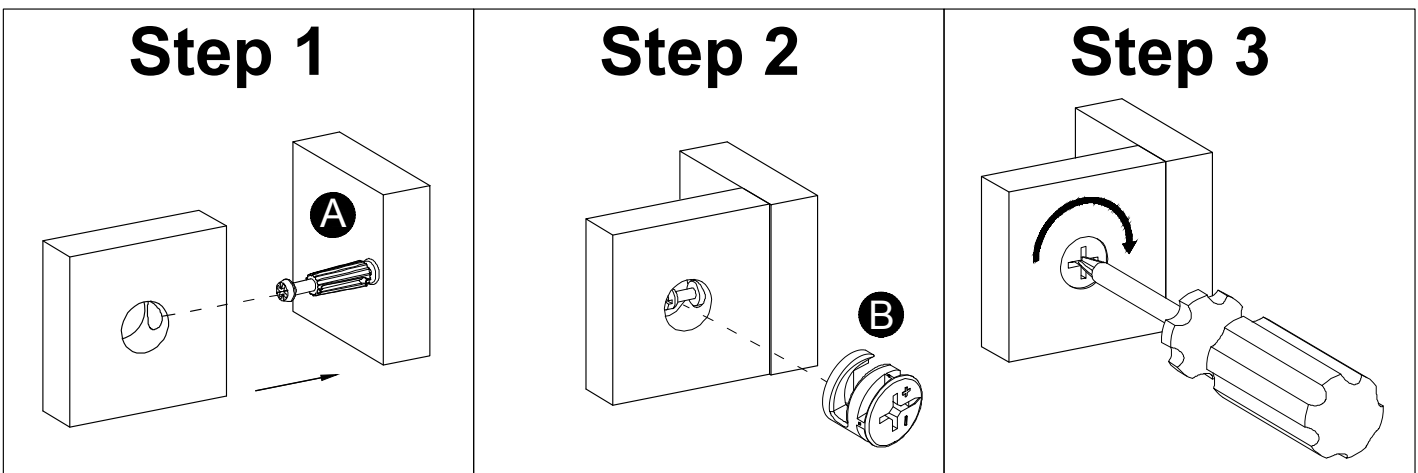

1

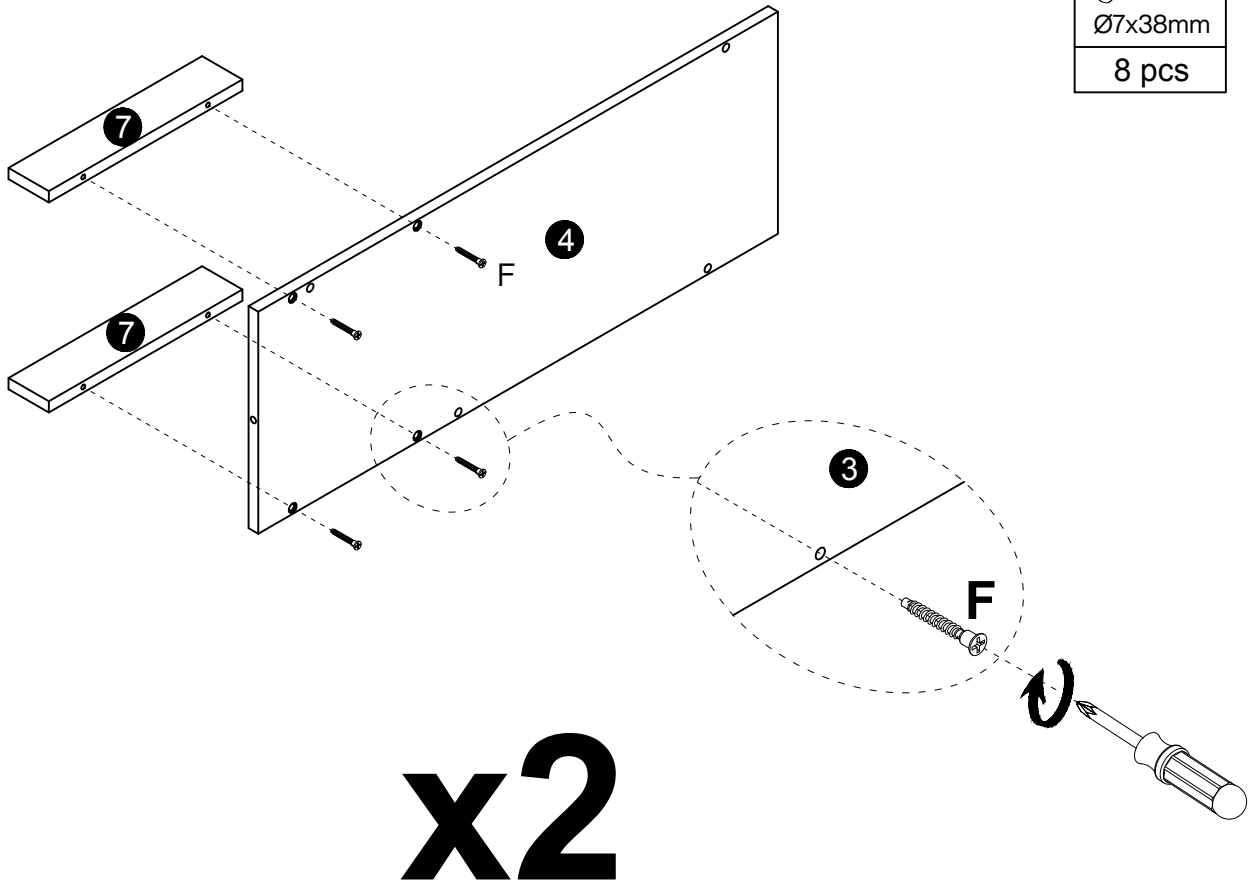

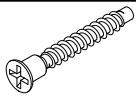
<b>F</b>

Ø7x38mm
8 pcs

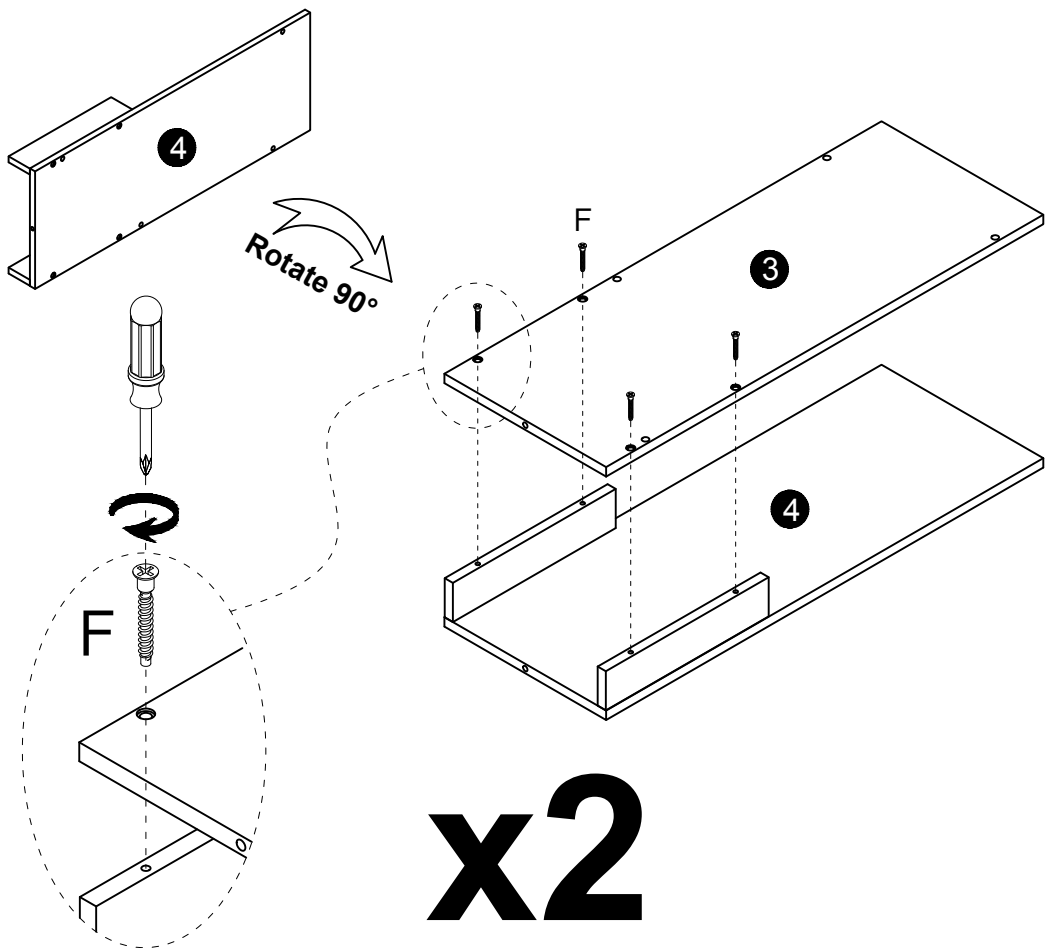
2

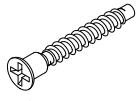

<b>F</b>

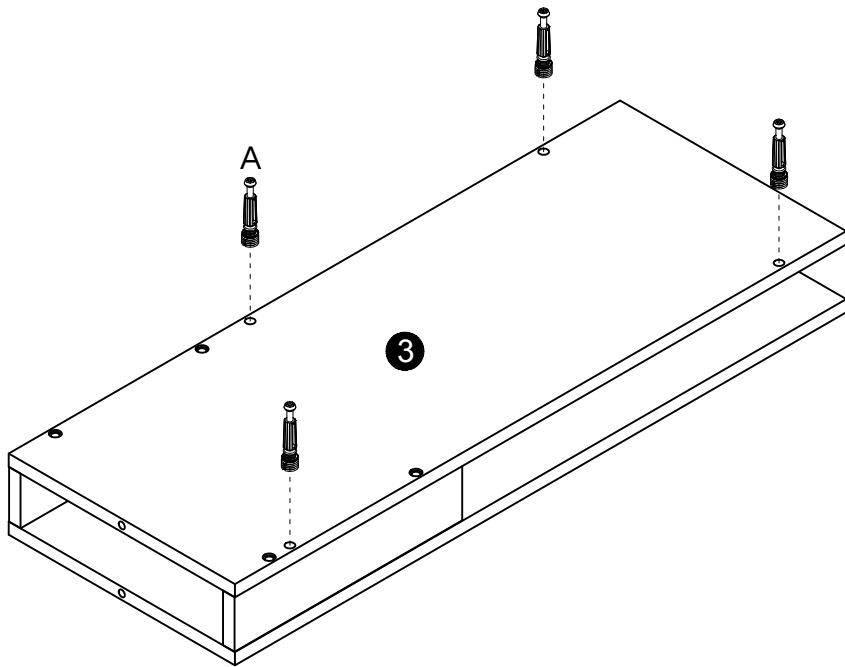
Ø7x38mm
8 pcs

3



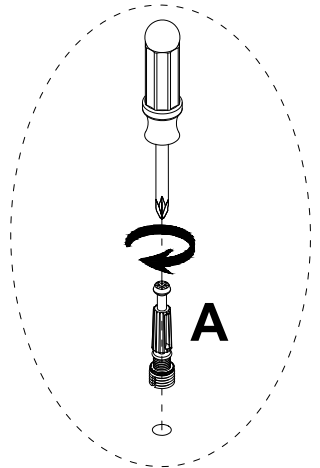

<b>A</b>

M6x35mm
8 pcs

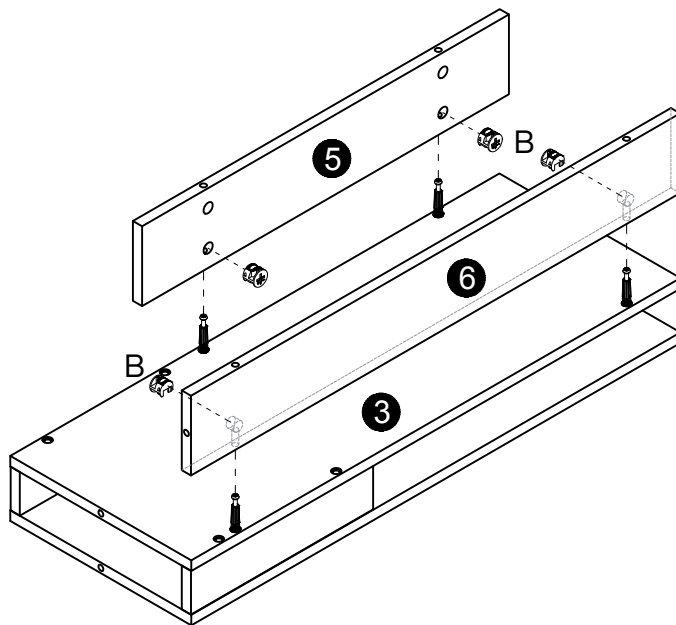
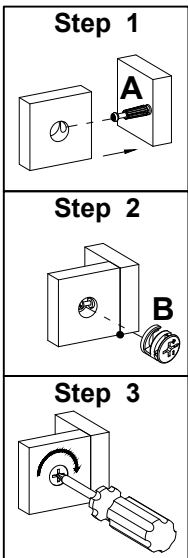

x2

4



<b>B</b>

Ø15x12mm
8 pcs

x2

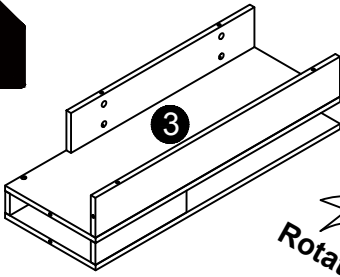
**5**

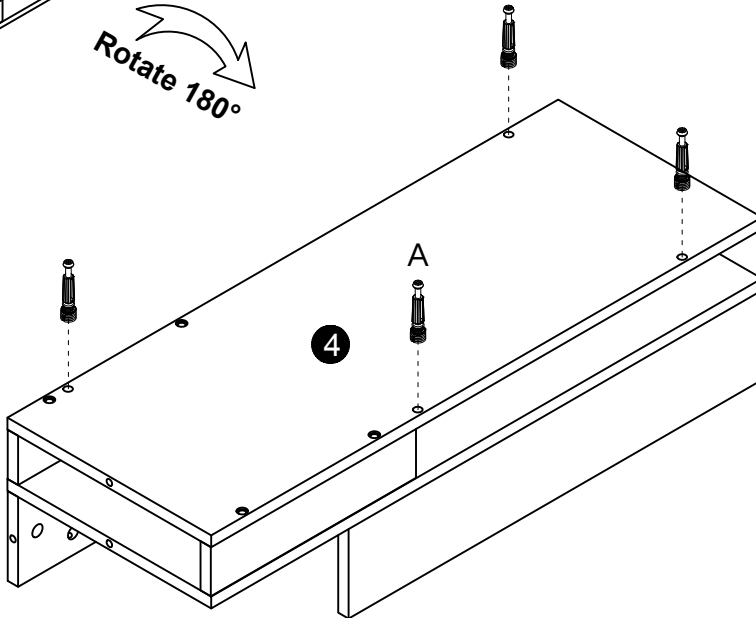

Rotate 180°



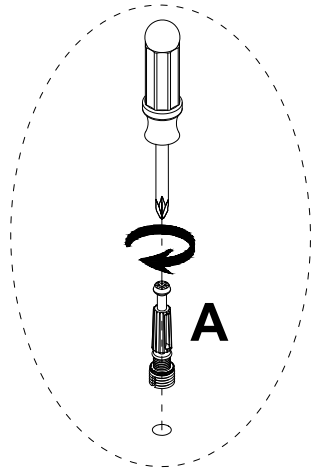

<b>A</b>

M6x35mm
8 pcs

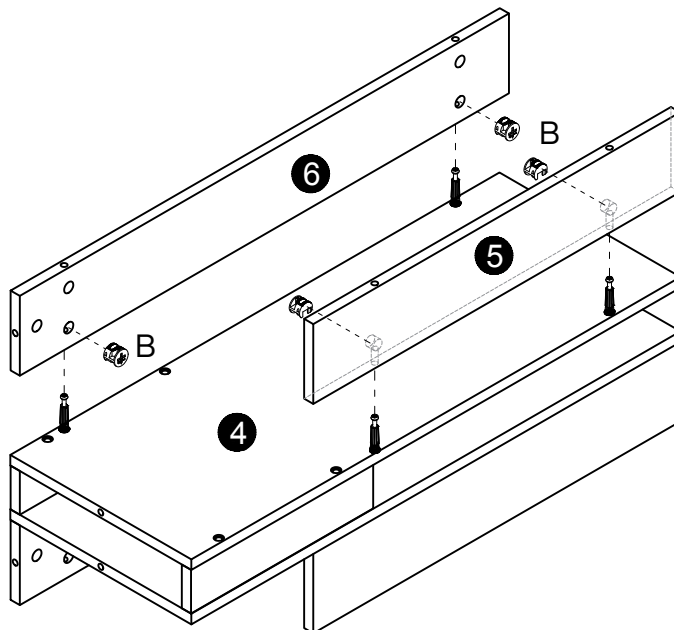
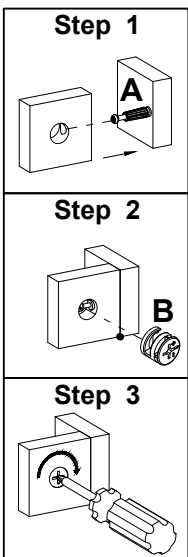

**x2**



**6**



<b>B</b>

Ø15x12mm
8 pcs

**x2**

7

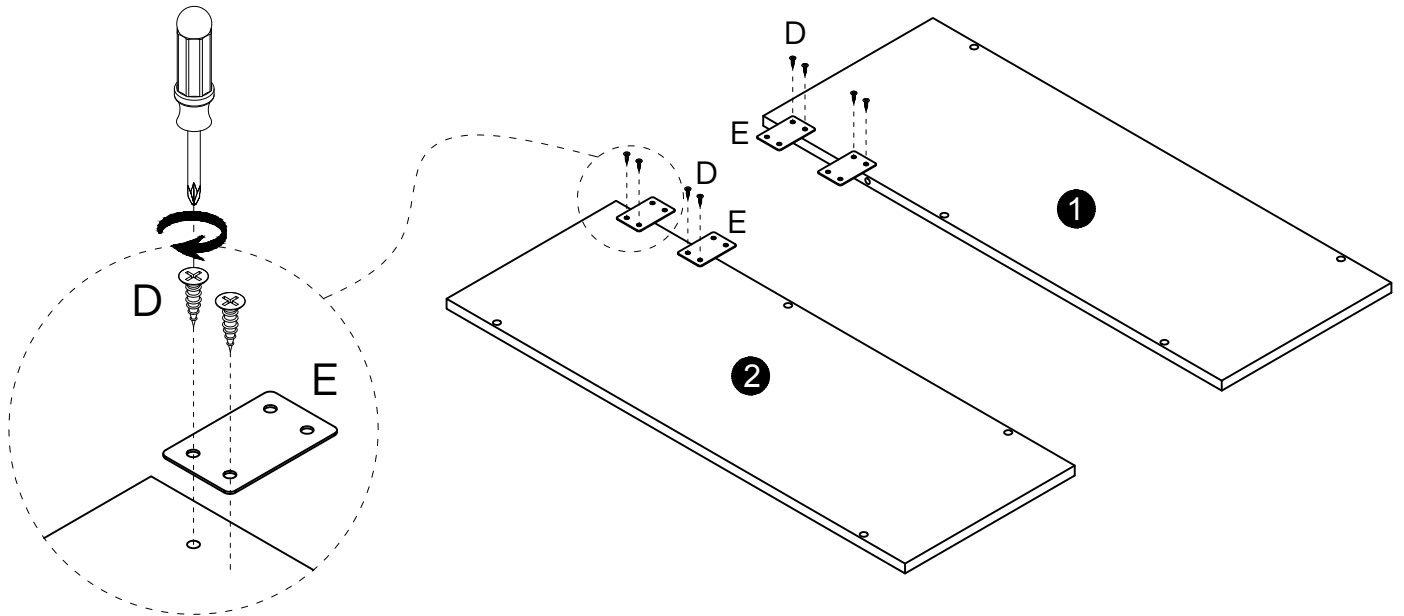
D	E
	
Ø3.5x14mm	60x38mm
16 pcs	8 pcs



x2

8

A

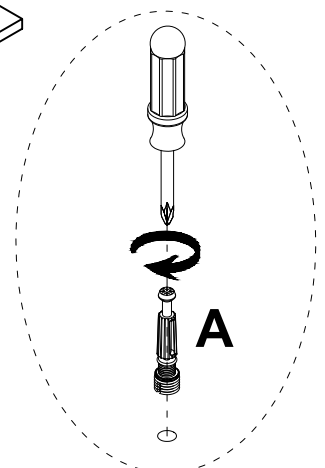
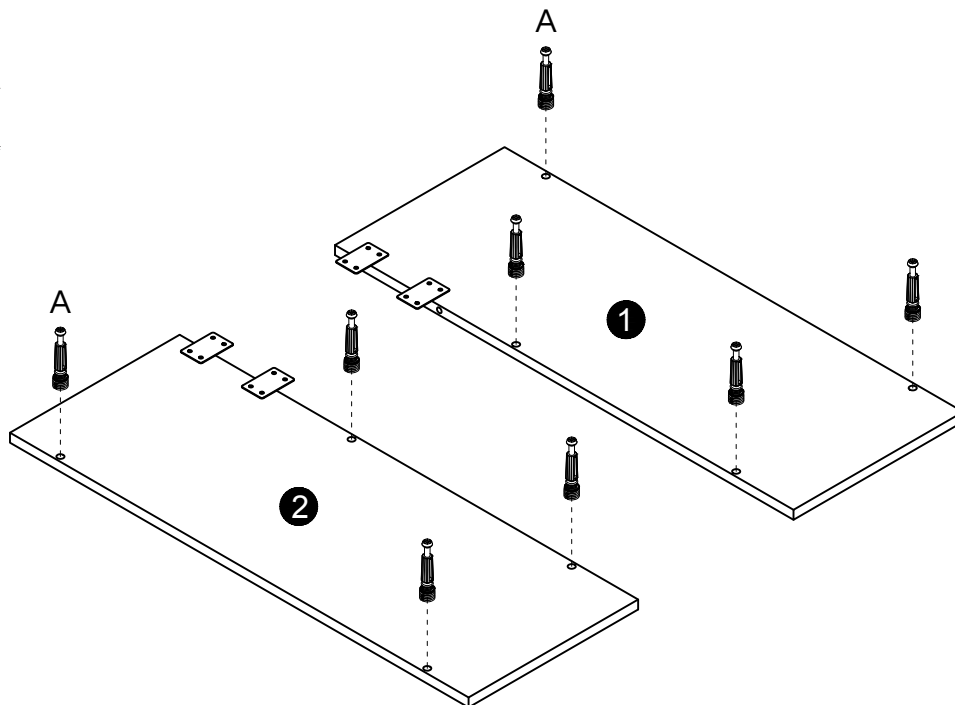
M6x35mm
16 pcs



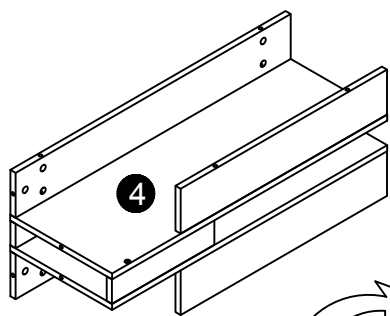

x2

9

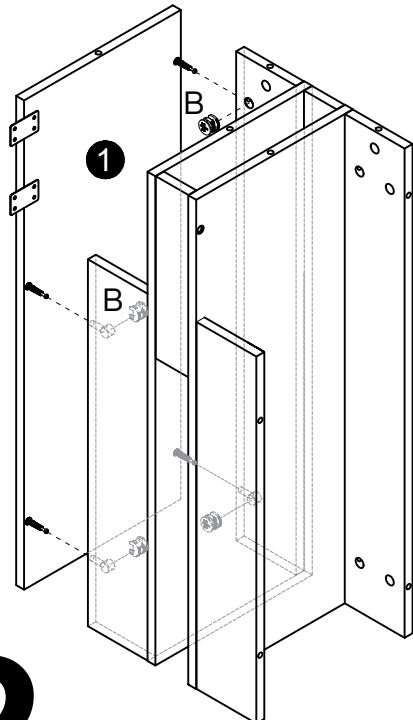

Rotate 90°



<b>B</b>

Ø15x12mm
8 pcs

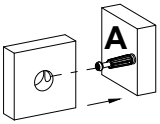
**Step 1**

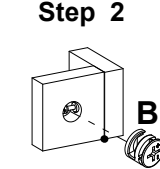

**Step 2**



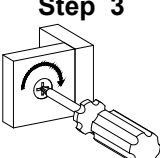

**Step 3**

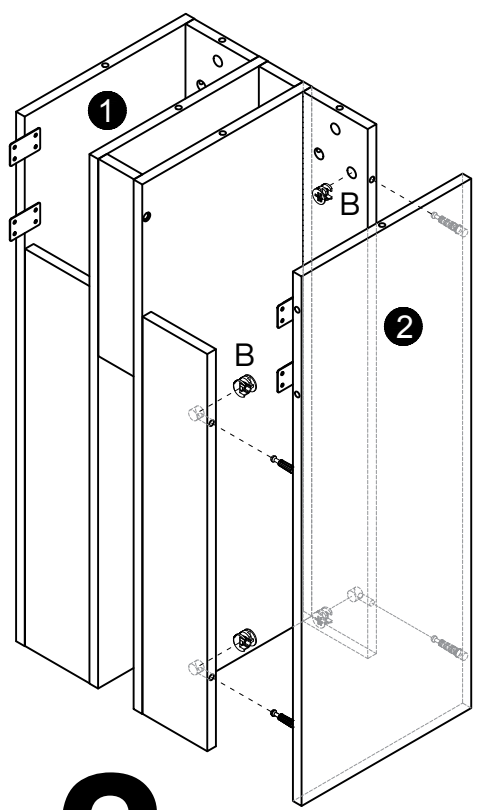

x2

10



<b>B</b>

Ø15x12mm
8 pcs

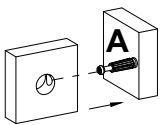
**Step 1**

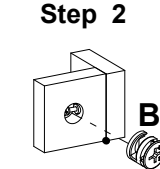

**Step 2**



**Step 3**

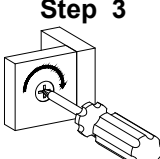

x2

11

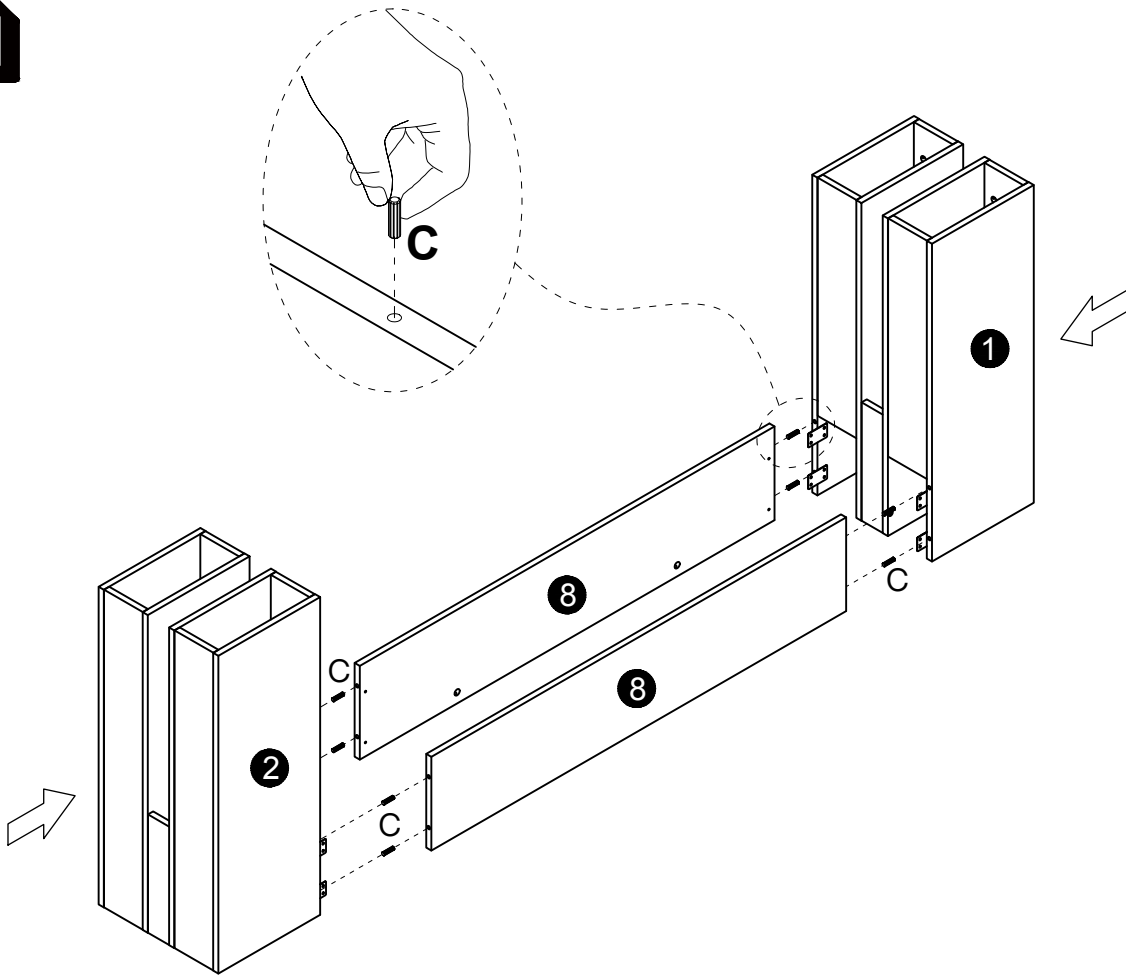

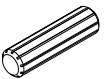
<b>C</b>

Ø8x30mm
8 pcs

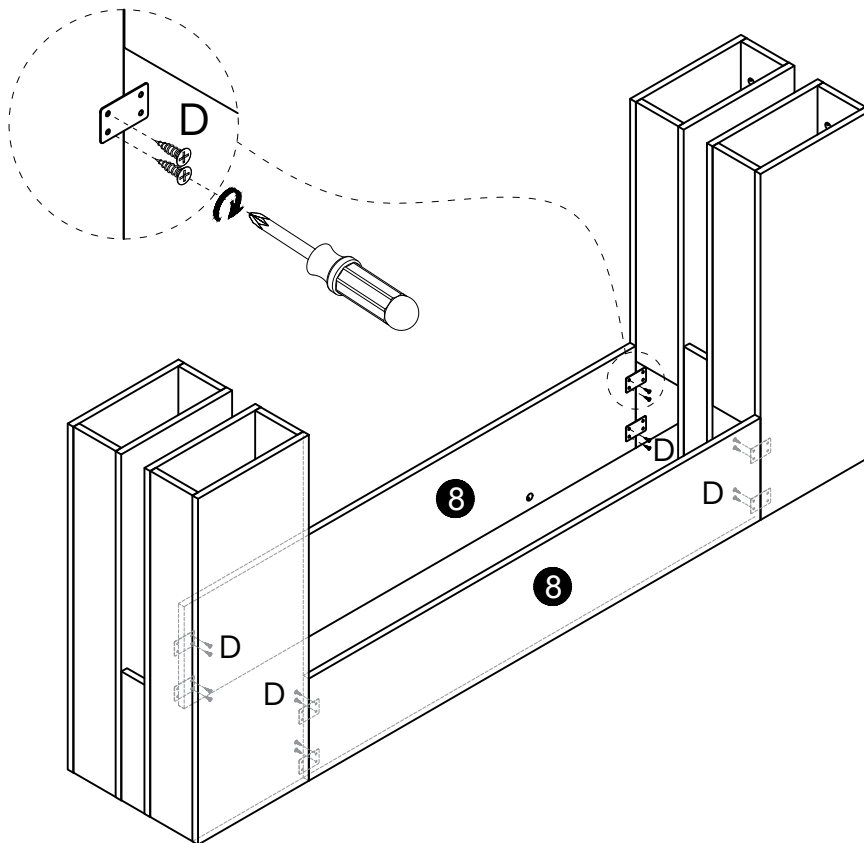
12

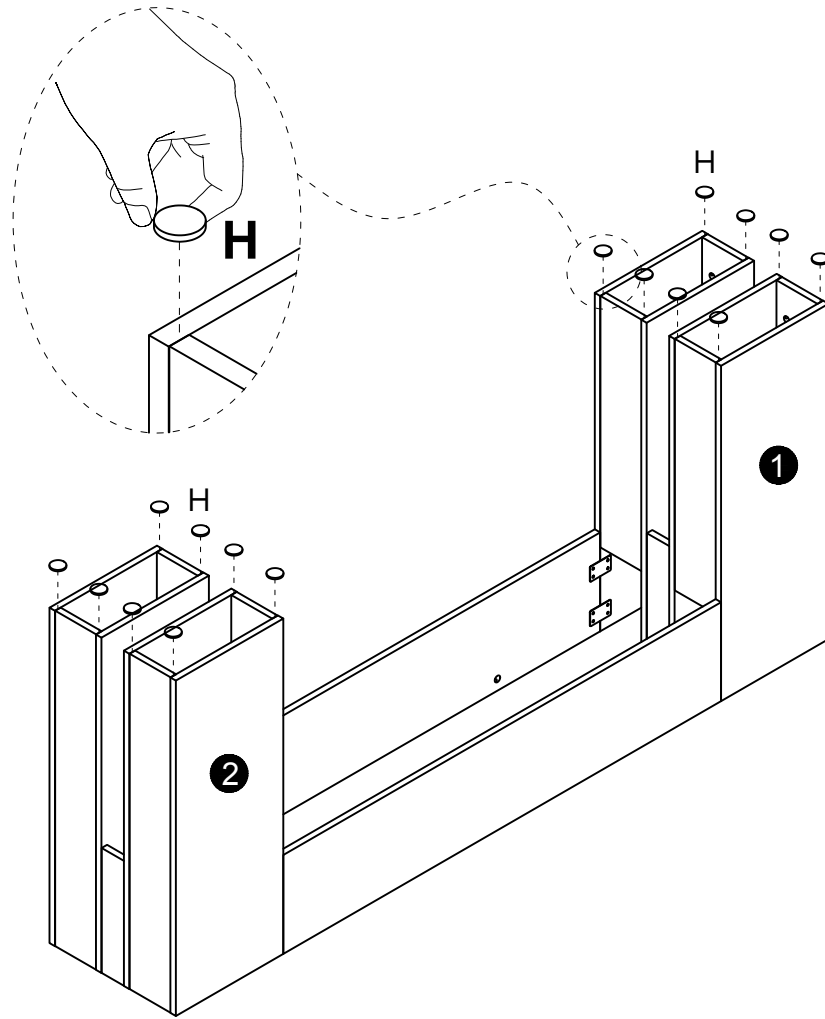

<b>D</b>

Ø3.5x14mm
16 pcs

13

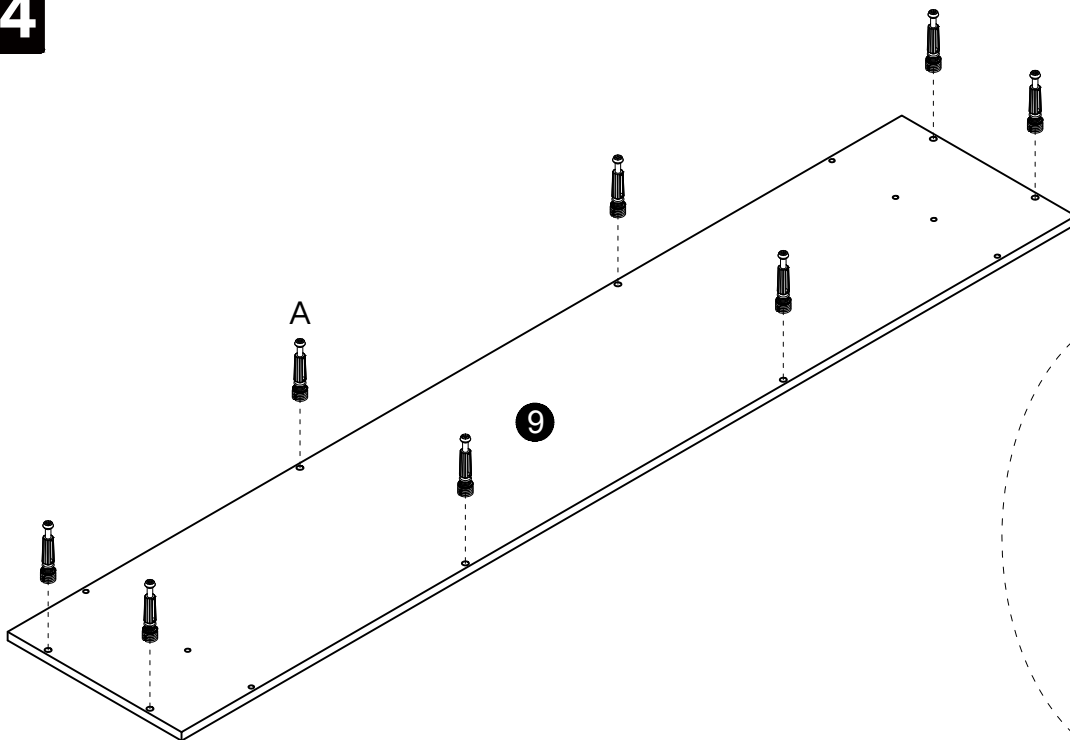

<b>H</b>

Ø16x3mm
16 pcs

14



<b>A</b>

M6x35mm
8 pcs

# 15

**Step 1**

**Step 2**

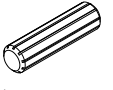
**Step 3**

B	C
	
Ø15x12mm	Ø8x30mm
8 pcs	8 pcs

Rotate 90°

# 16

**G**

1 pc

17

Step1

Wall

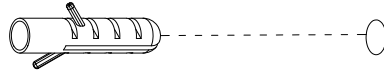

Step2

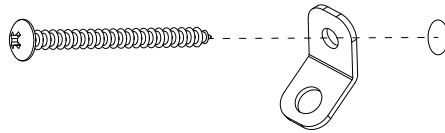

Step3

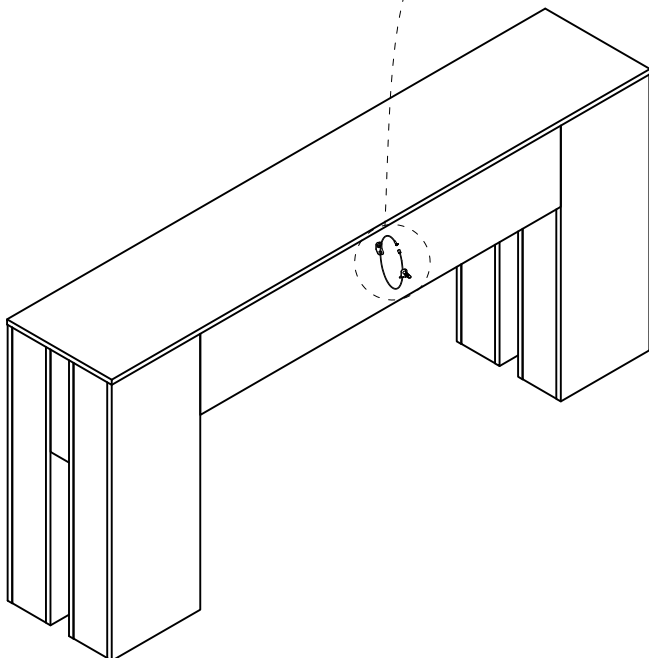
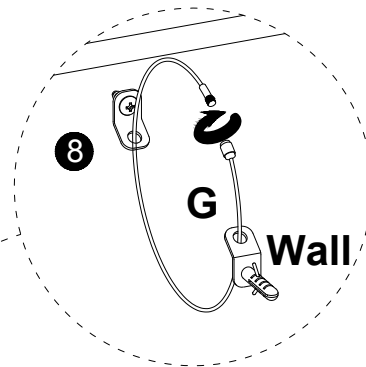

**Thank you for your support !**

