

HLG044

Version : 2.0

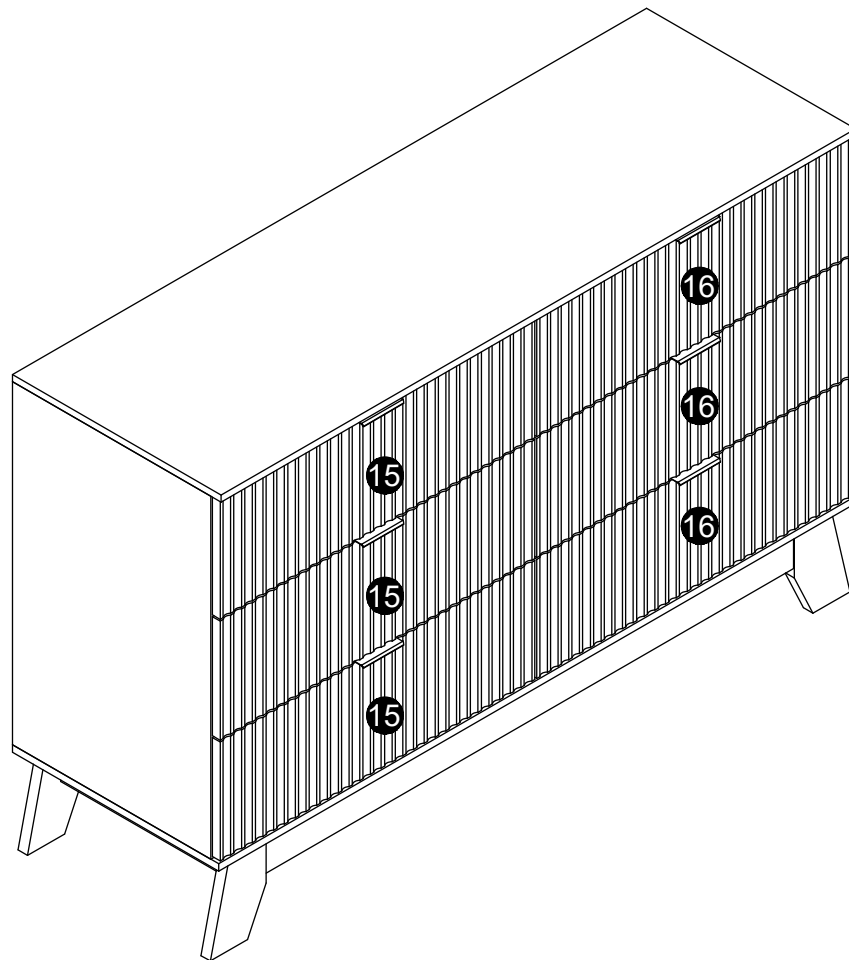

IT IS RECOMMENDED
TO USE POWER TOOLS

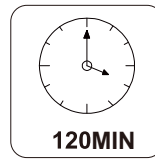
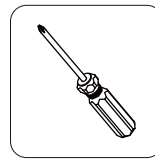
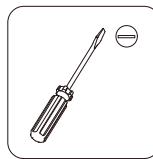

120MIN

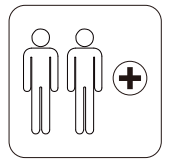

EN_IMPORTANT, RETAIN FOR FUTURE REFERENCE: READ CAREFULLY.

. THANK YOU FOR PURCHASE! .

FREE REPLACEMENT PARTS AVAILABLE!



---NEED HELP WITH YOUR FURNITURE?---

Scan the QR code to contact us!



If you're experiencing any issues—whether due to shipping, assembly, or any other reason
—we're here to help.

For any damaged or missing components, we're happy to provide FREE replacement parts.



WhatsApp

Email: support@anymaple.com

WANT TO CONTACT US THROUGH AMAZON?

- ▶ Log in to your Amazon account.
- ▶ Go to “Your Orders” and locate your furniture order.
- ▶ Click on “Get Help with Order” to send us a message directly.

Our customer support team is ready to assist you and we will respond within
12-24 HOURS to resolve your concerns quickly!

USING CAM LOCK AND QUICKFIT

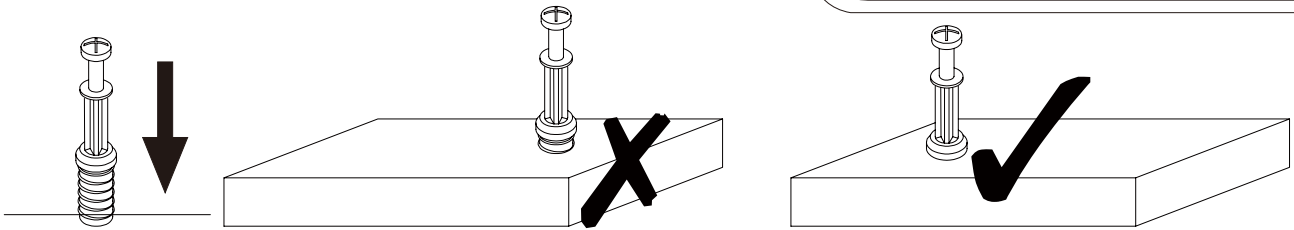

EN_QUICKFIT: Tighten quickfit until shoulder is flush with panel. Do not overtighten or undertighten.

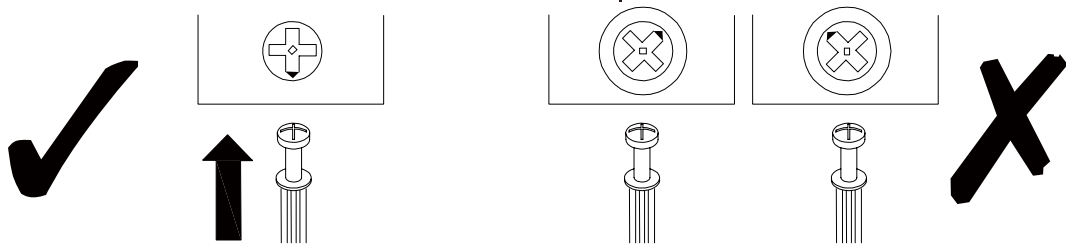

EN_CAM LOCK: When fitting cam lock, ensure starting position is correct before you insert connecting quickfit.

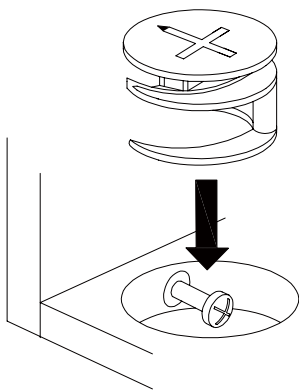

EN_Quickfit head should be in the centre of the cam lock when the two panels are joined.
Cam lock should be inserted before quickfit.

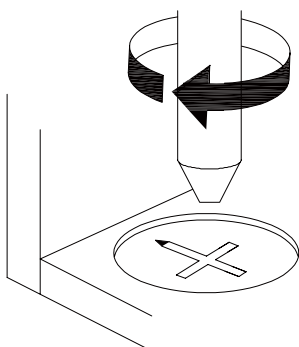

EN_Turn cam lock clockwise to tighten.

PACKING DELALS

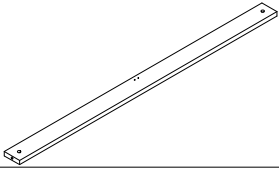
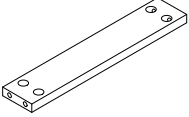
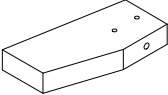
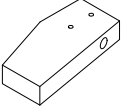
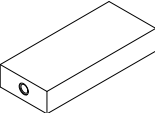
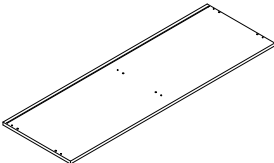
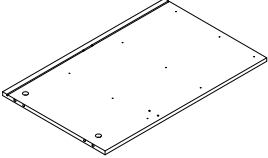
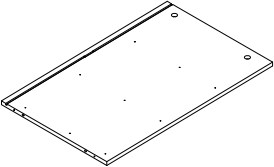
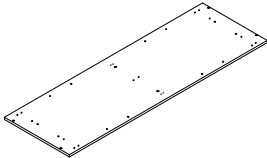
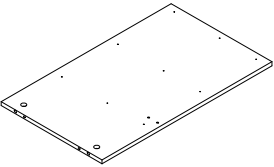
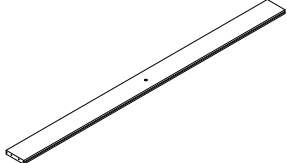
NO.	PARTS	QTY	SPARE
①		x2	
②		x2	
③		x2	
④		x2	
⑤		x1	
⑥		x1	
⑦		x1	
⑧		x1	
⑨		x1	
⑩		x1	
⑪		x1	

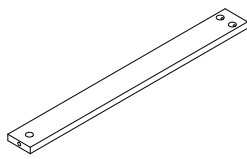
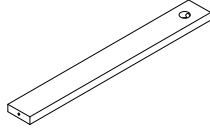
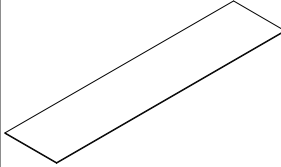
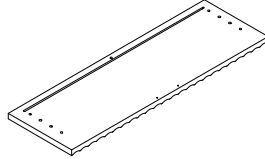
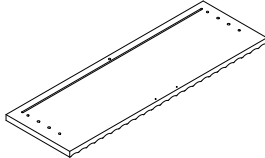
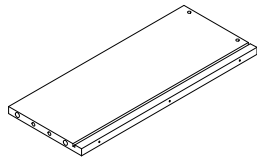
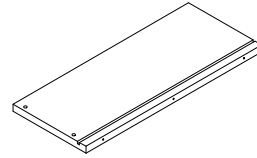
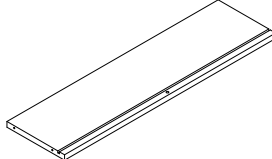
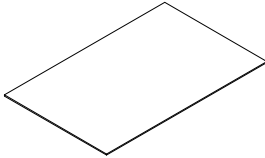
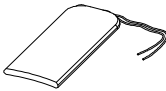

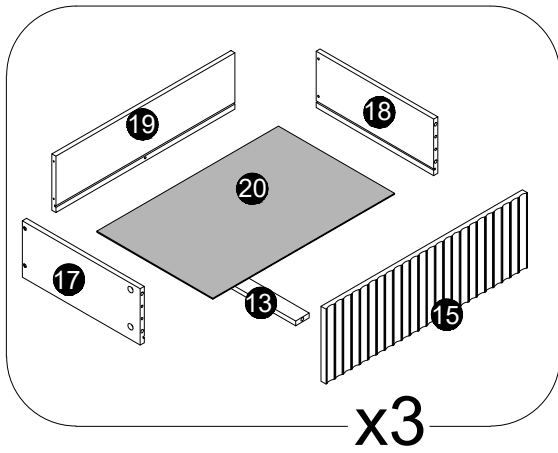
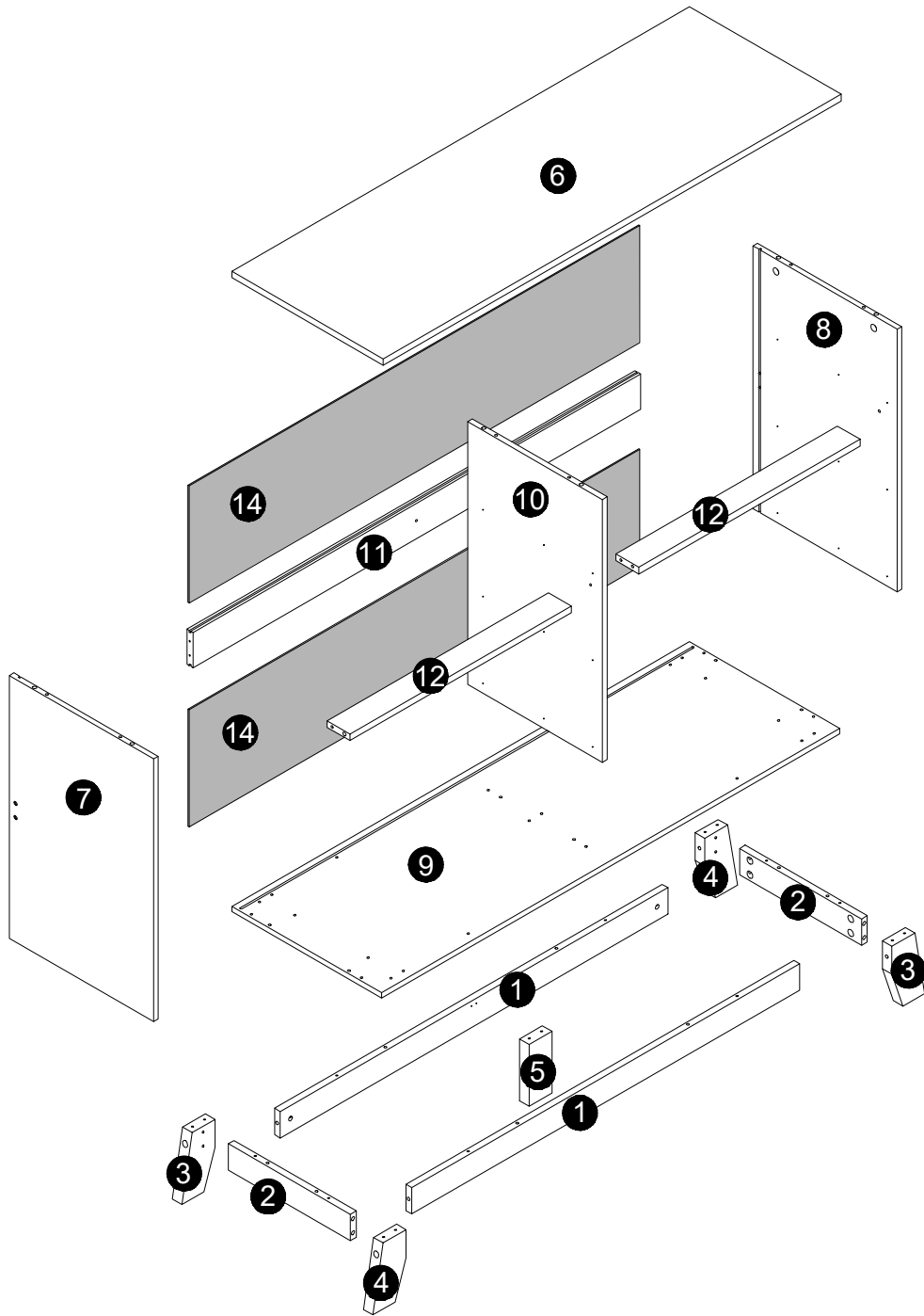



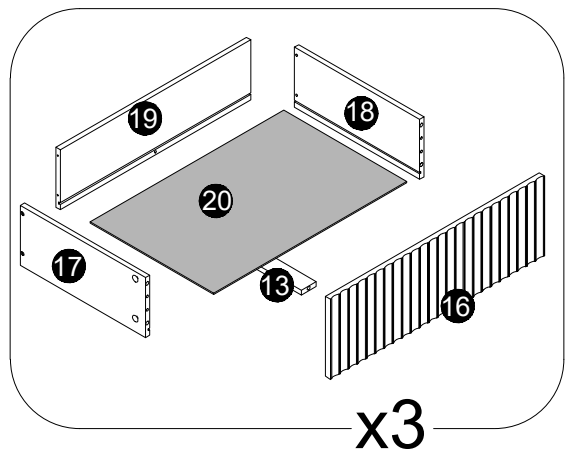







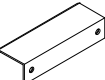



NO.	PARTS	QTY	SPARE
⑫		x2	
⑬		x6	
⑭		x2	
⑮		x3	
⑯		x3	
⑰		x6	
⑱		x6	
⑲		x6	
⑳		x6	
			
	Hardware Kit		

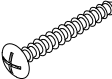

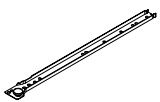
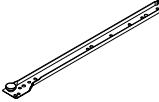
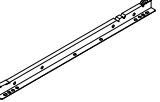
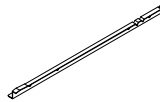
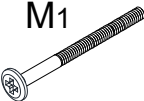



x3



x3

 A x50 Ø6x35mm +3(spare)	 B x50 Ø15x10mm +3(spare)	 C x44 Ø6x30mm +3(spare)	 D x41 Ø4x35mm +3(spare)	 E x72 Ø3.5x12mm +5(spare)	 F1	 F2 x6
 G x2	 H1	 I1	 I2	 J x2 Ø4x14mm	 K x18 Ø5x35mm +1(spare)	 L x1
 CL x6 L350mm	 CR x6 L350mm	 DL x6 L350mm	 DR x6 L350mm	 M1	 M2 x4	 N x2
 O x8 Ø4x12mm	 P x4	 Q x8				

 A x15	 B x15	 D x15	 C x12	x3	01
---	--	---	---	-----------	-----------

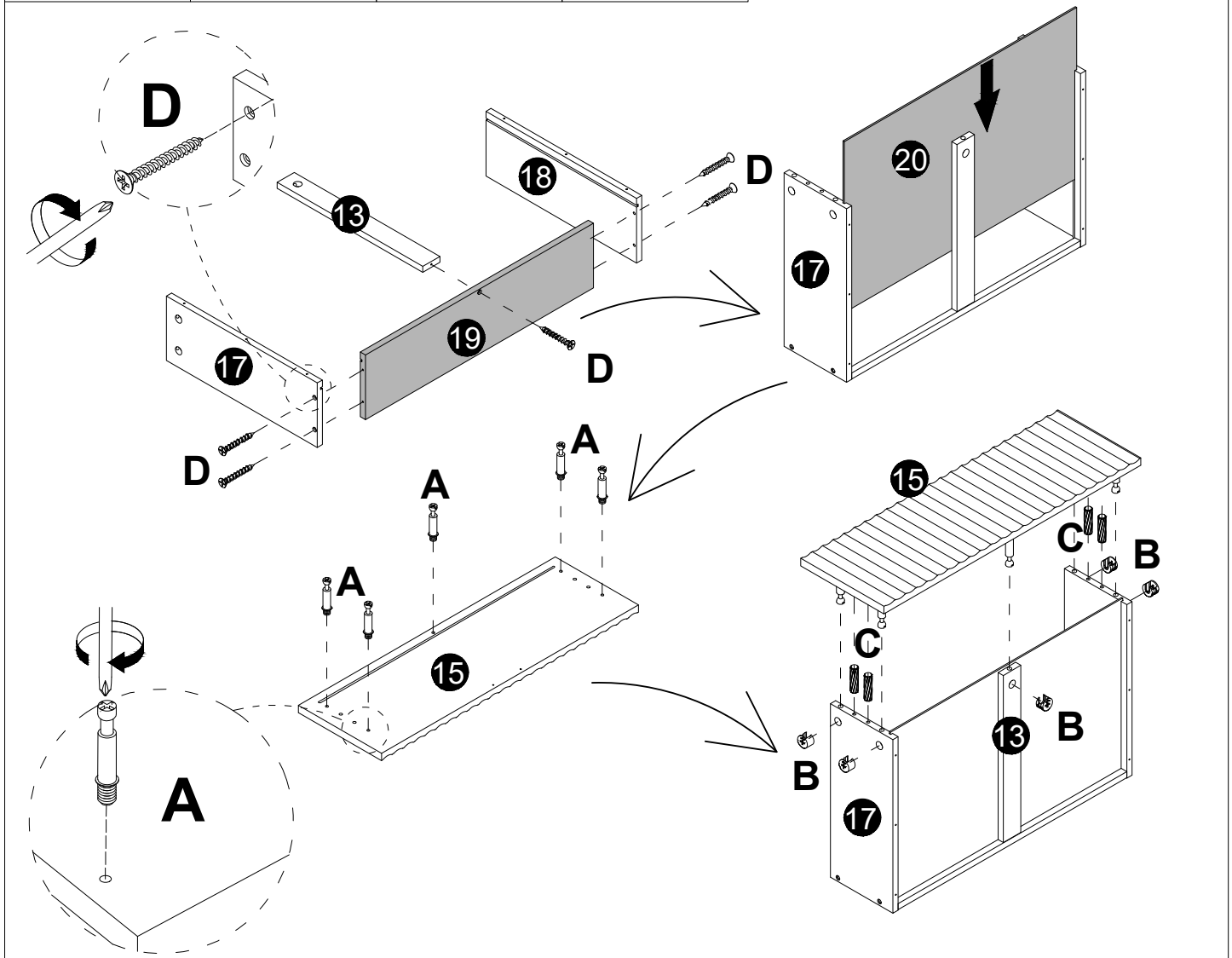

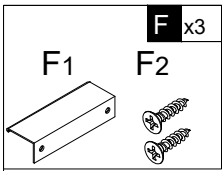

x3 02

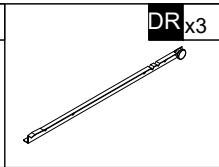
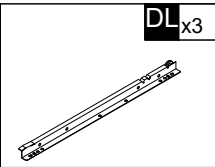
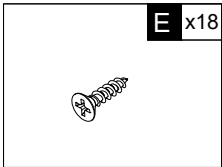
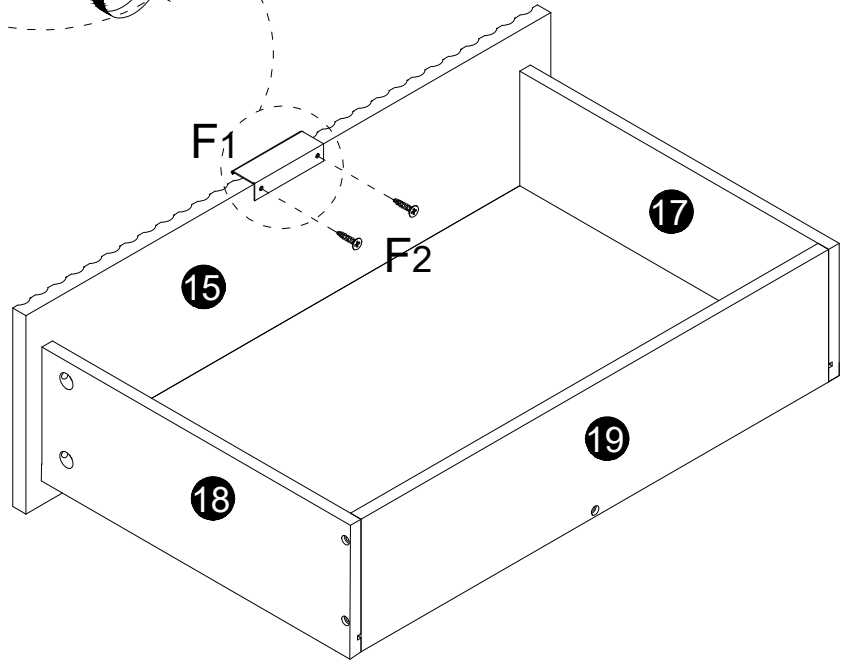
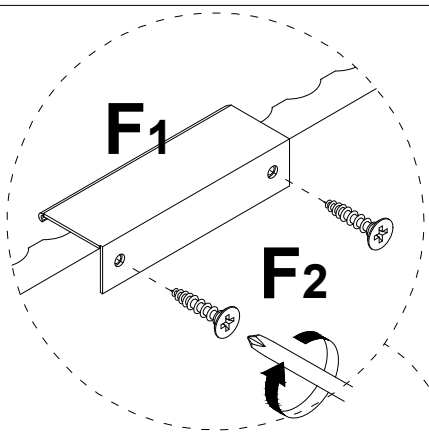

x3 03

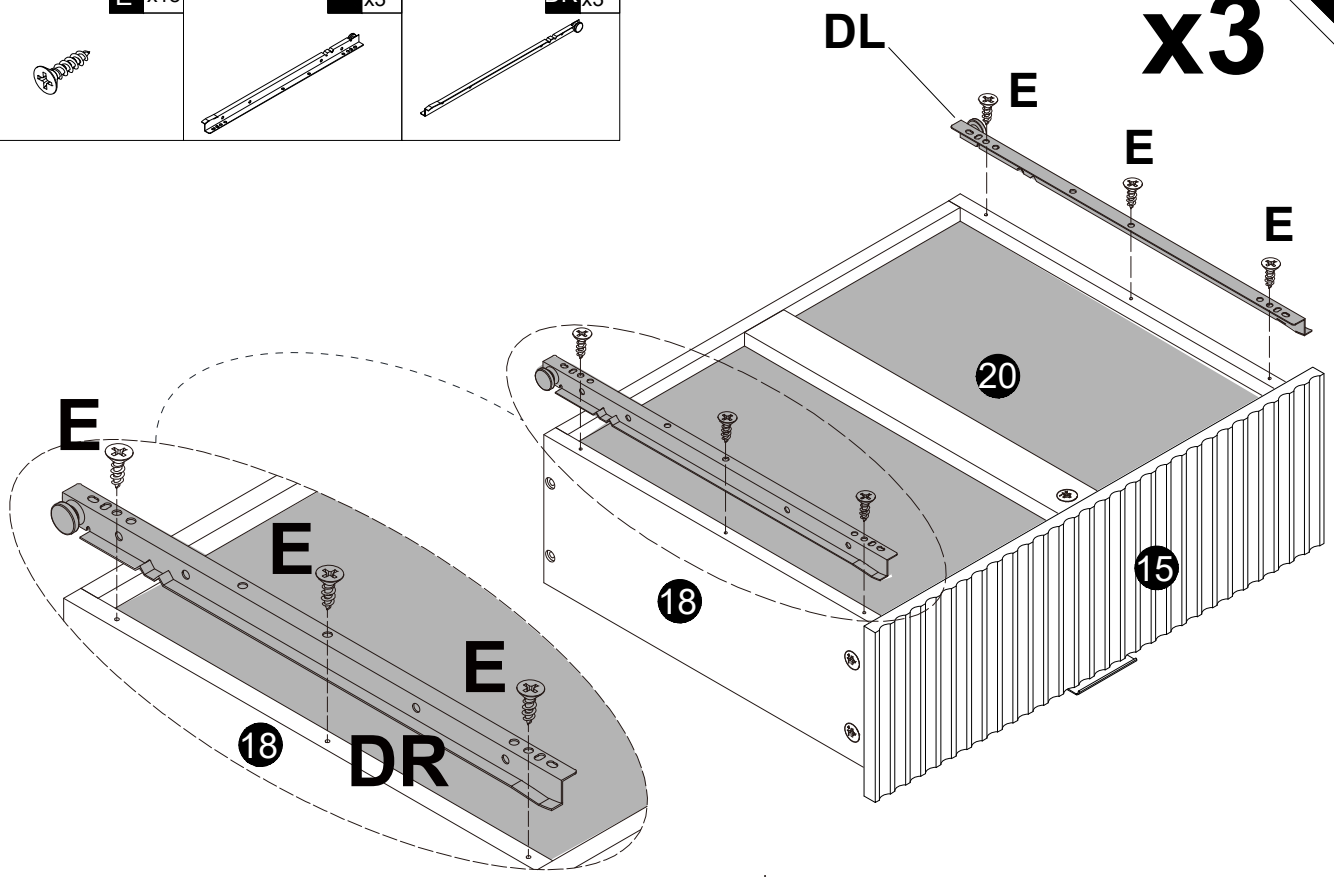

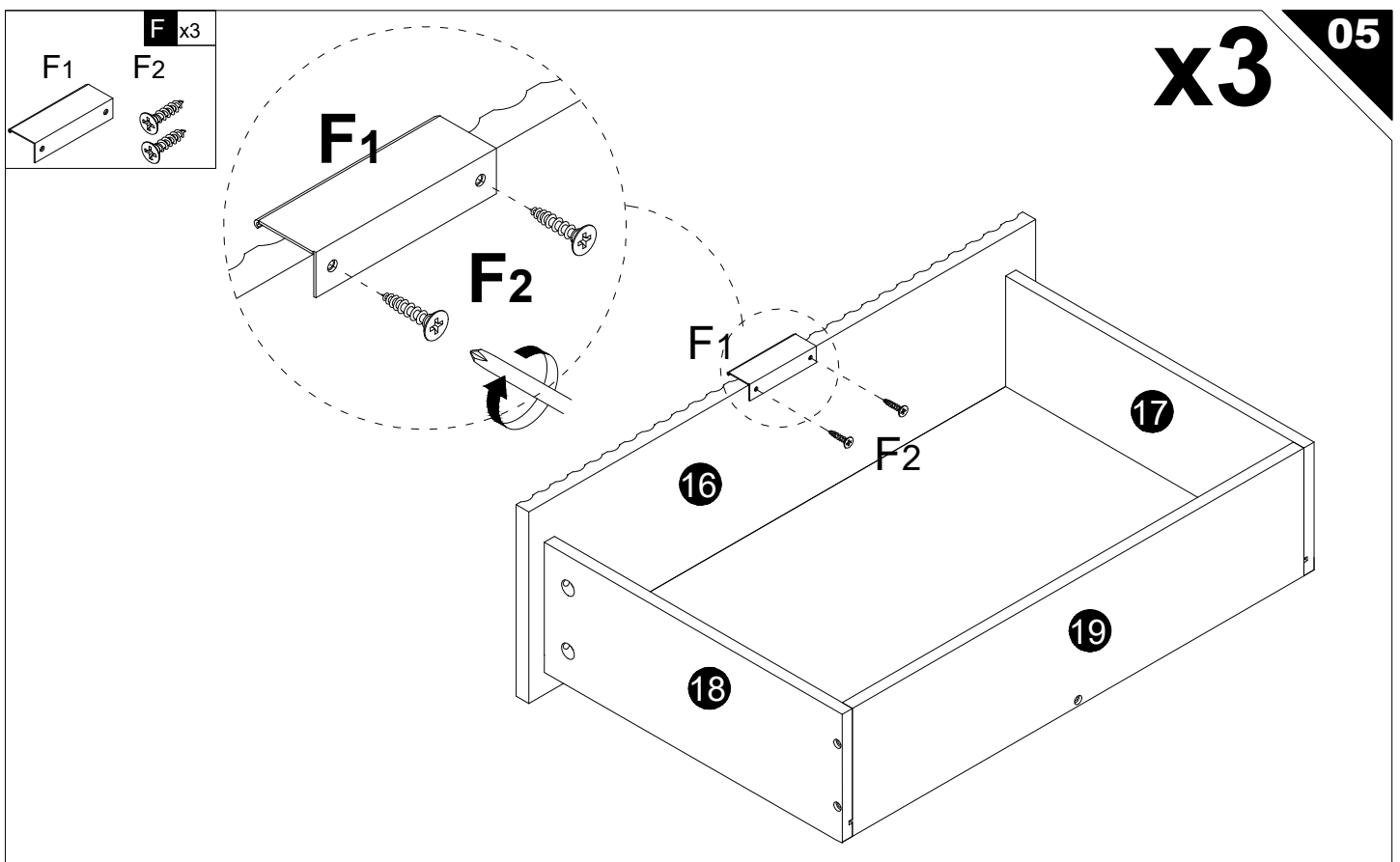
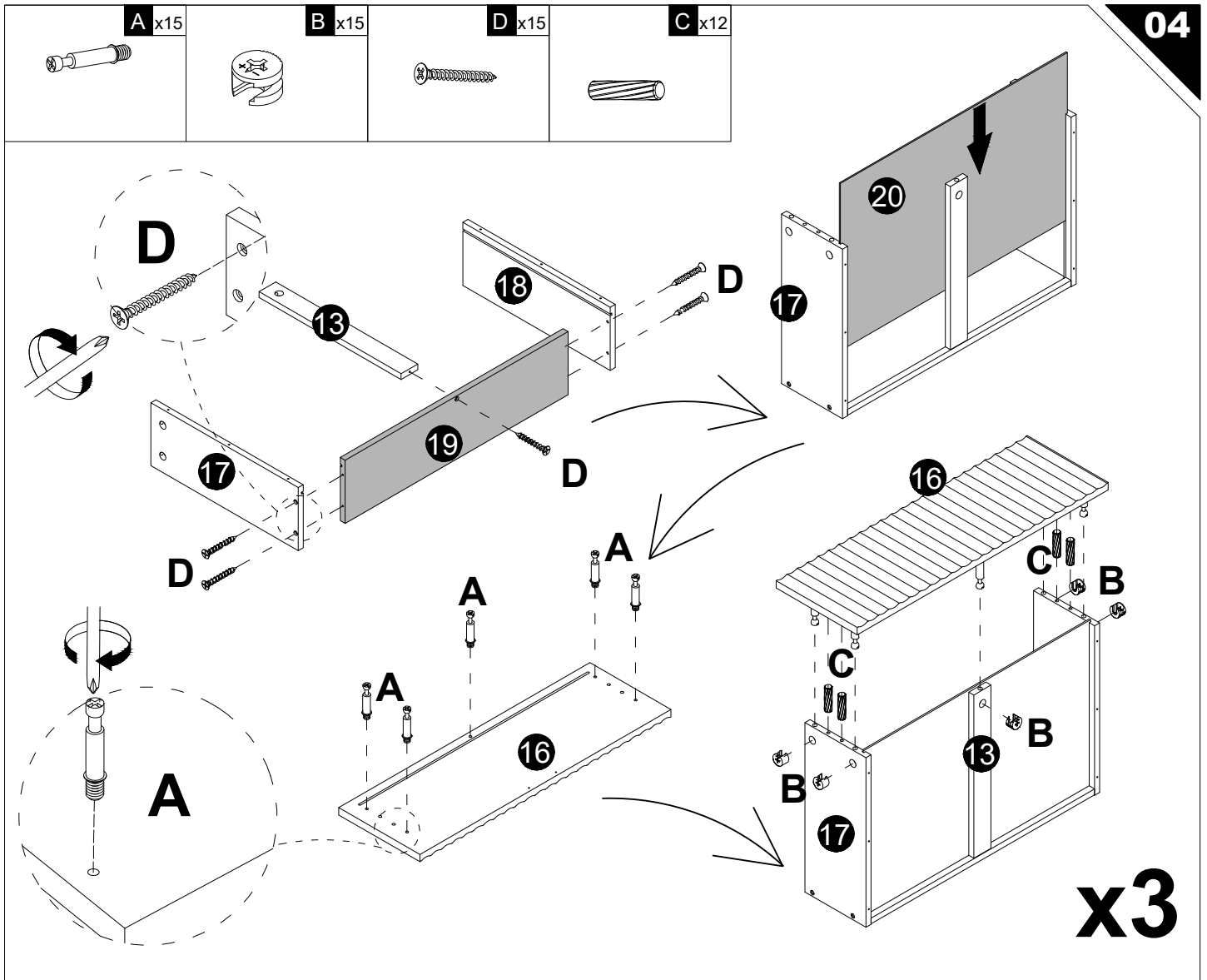

E x18

DL x3

DR x3

x3

06

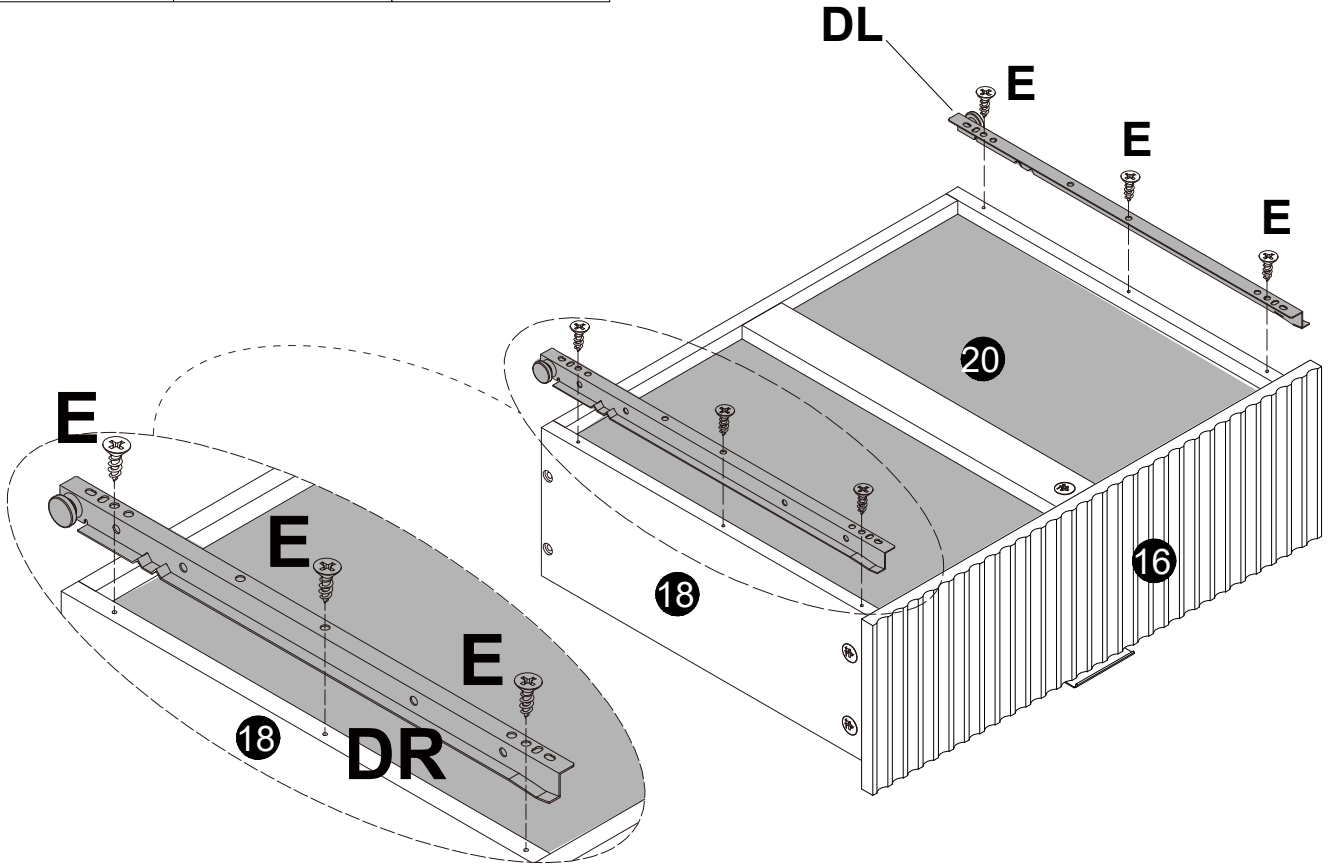
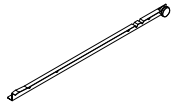
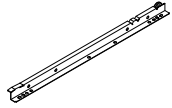

A x8

B x8

07

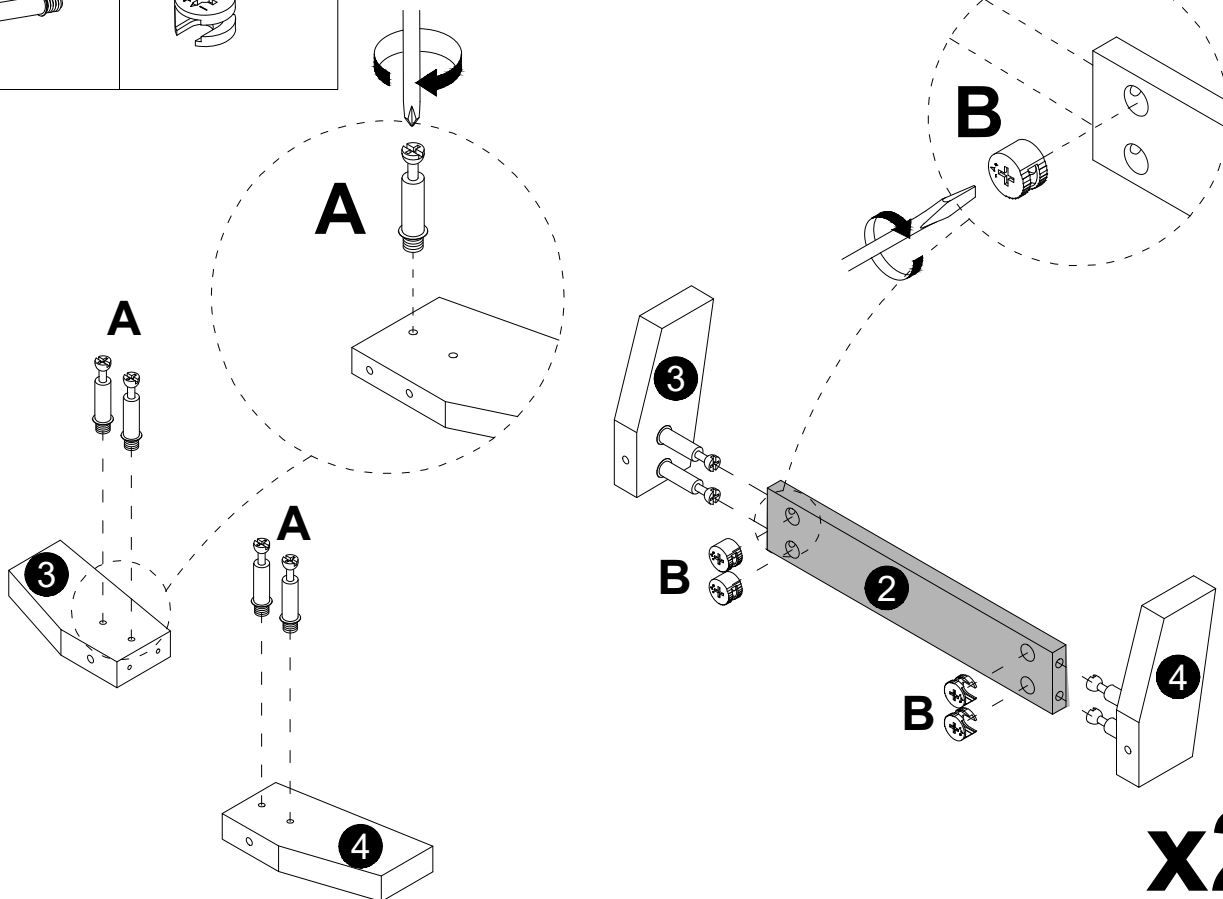
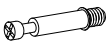

x2

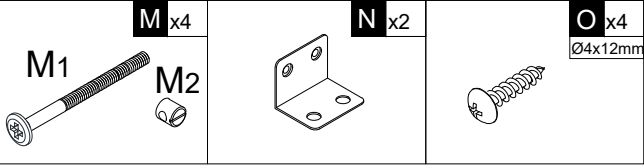

x2

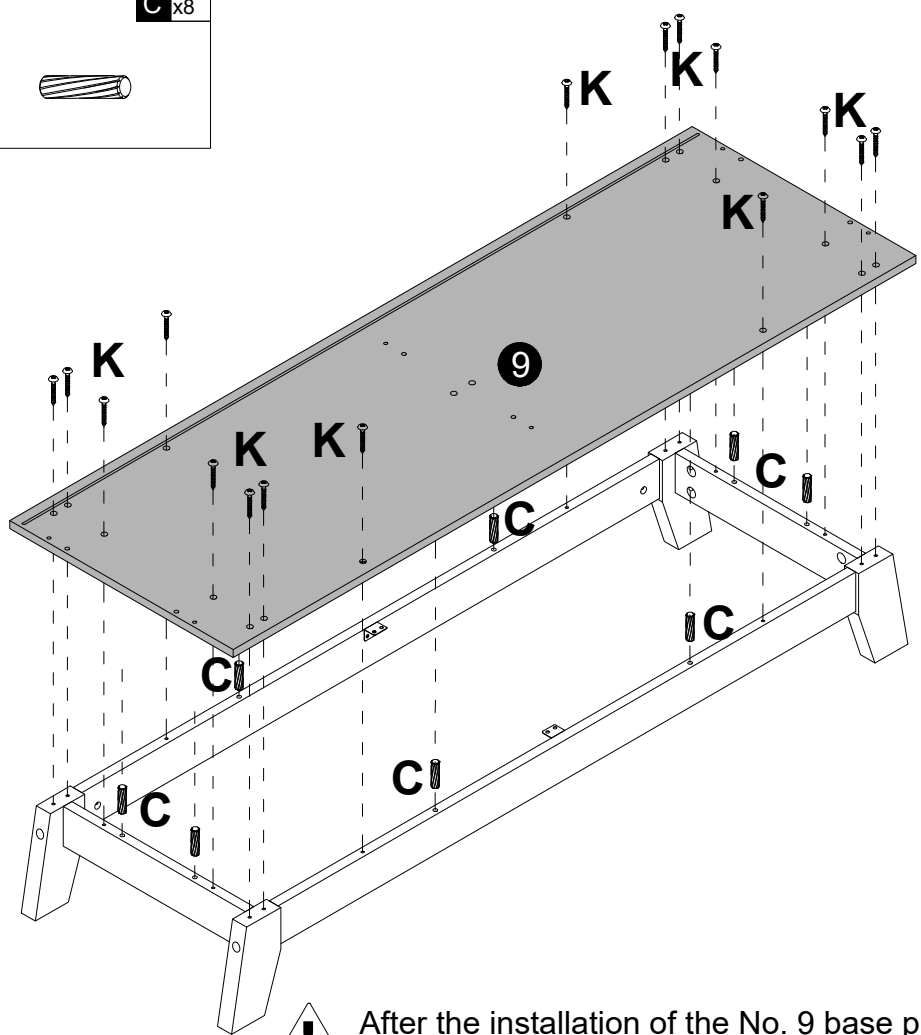
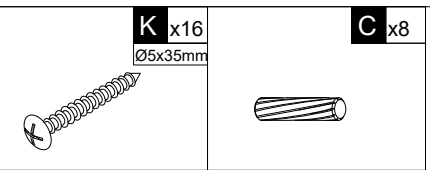
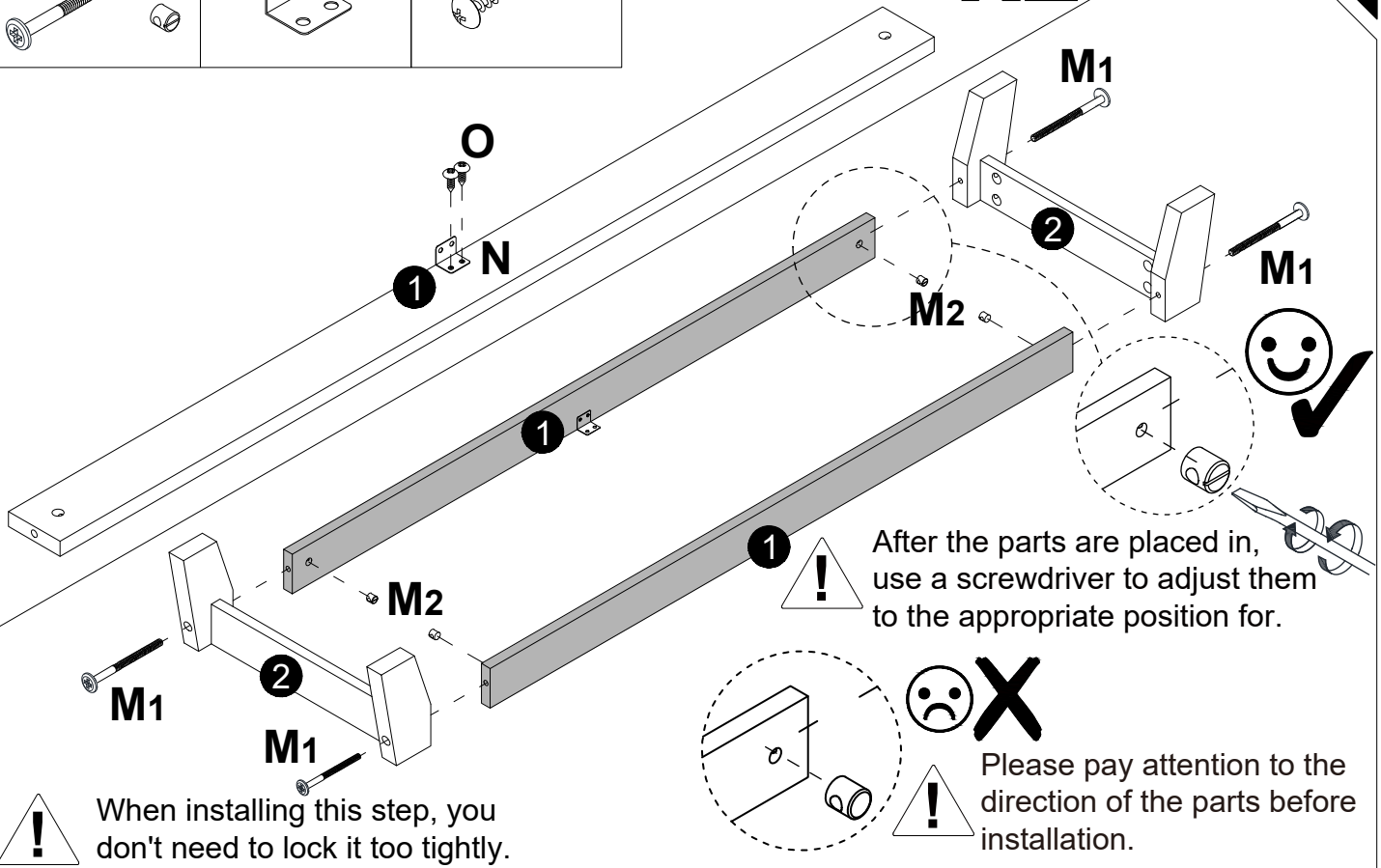

After the installation of the No. 9 base plate is completed, the lock M bolt is once again fully fixed on the leg

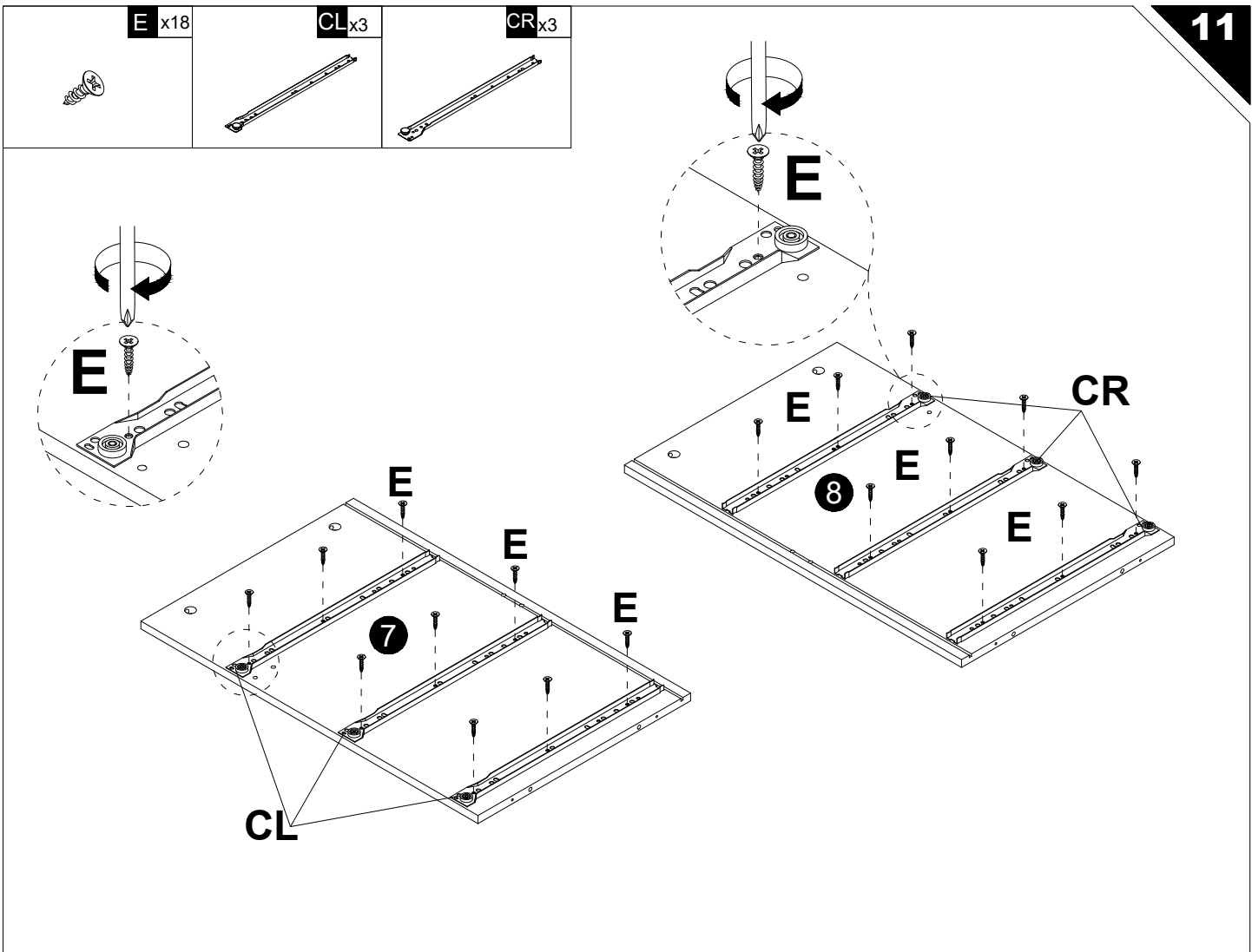
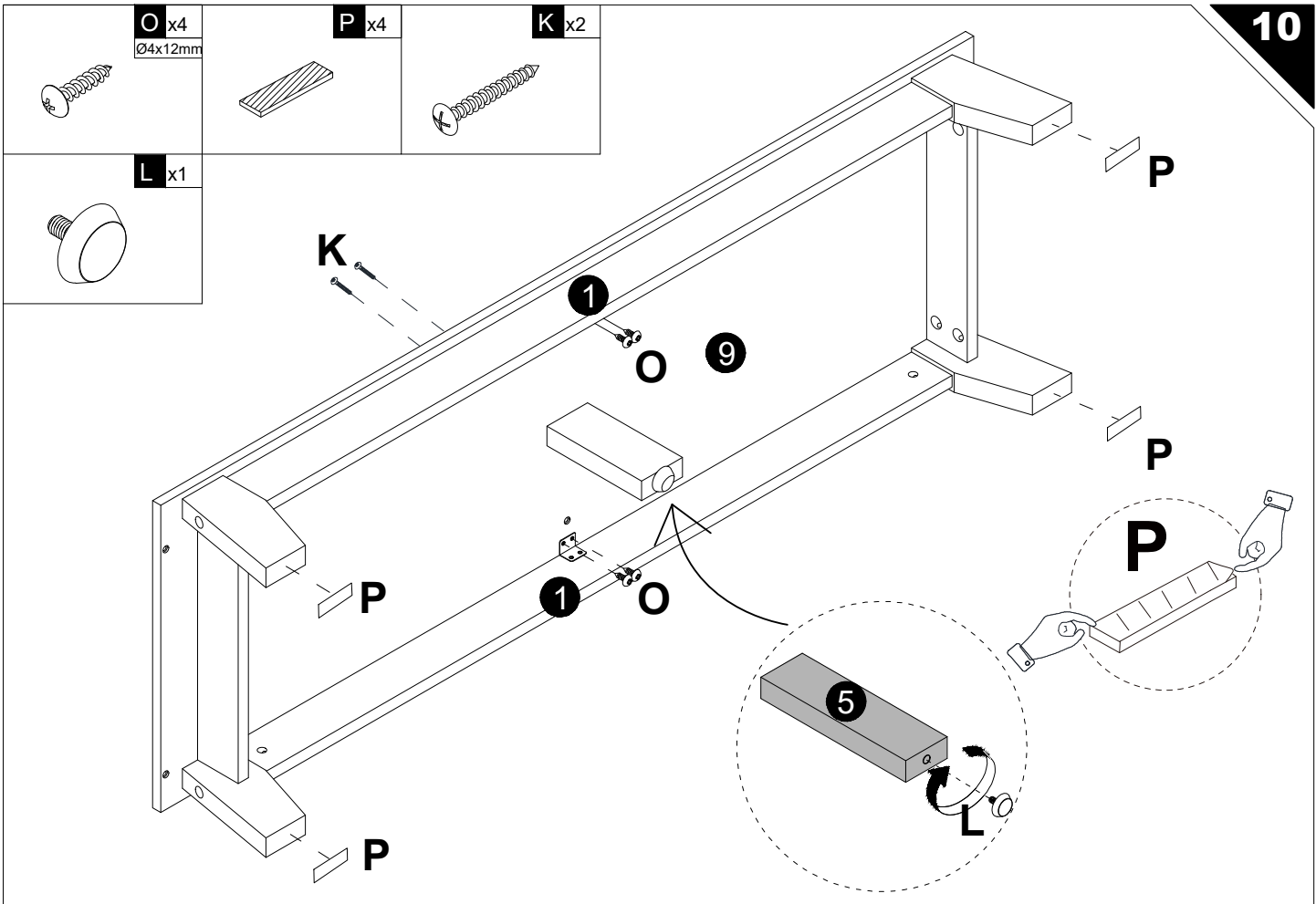

A x3

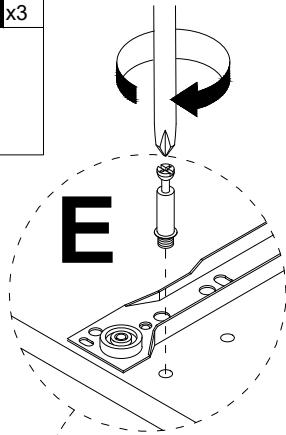
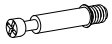

E

A

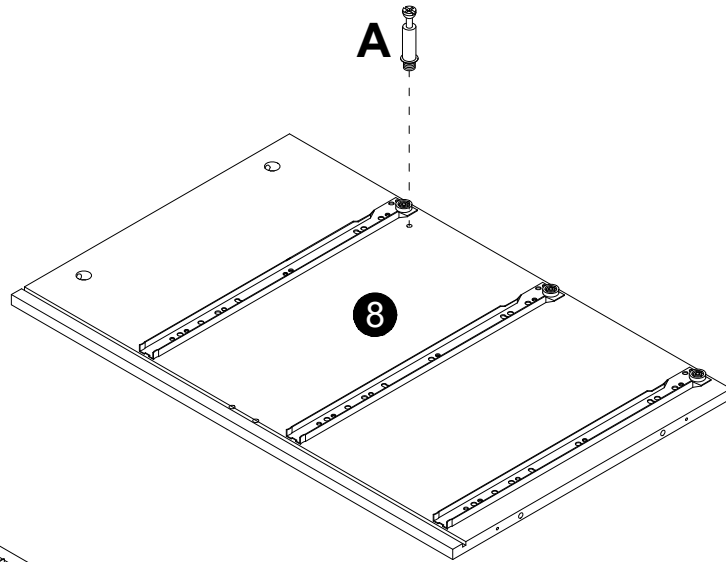

8

A

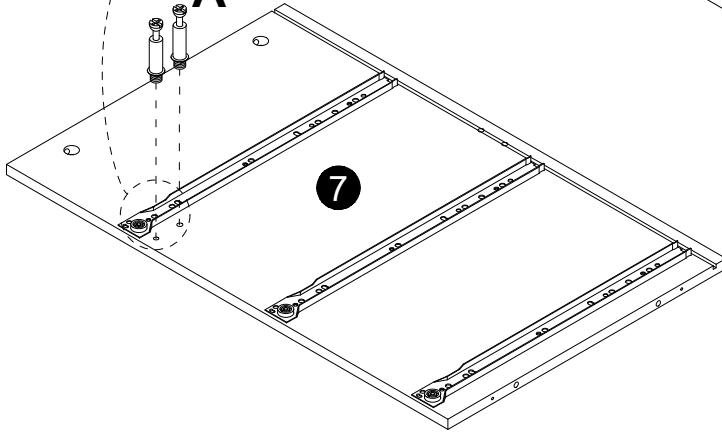

7

A x2

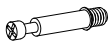

E x9



CL x3

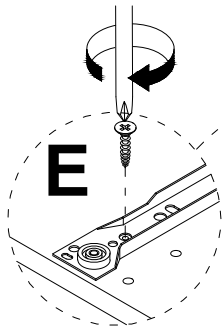
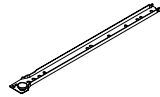

E

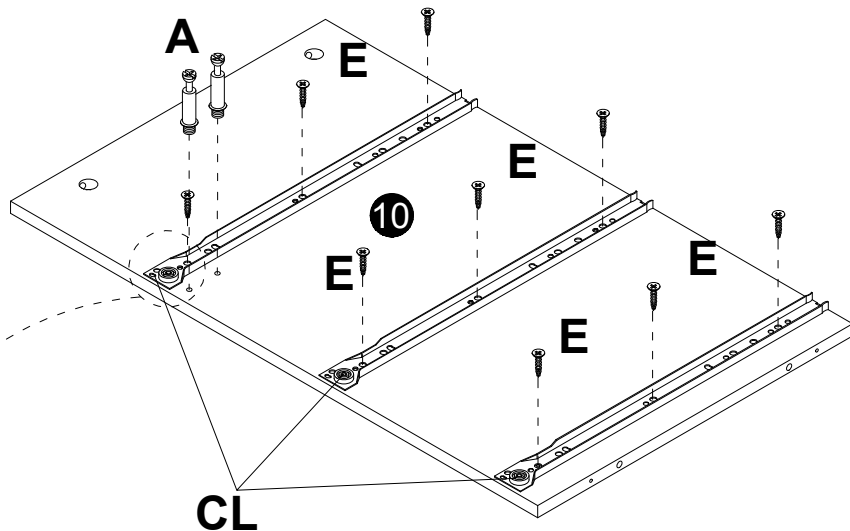

A

E

10

E

E

CL

A x1

E x9

CR x3

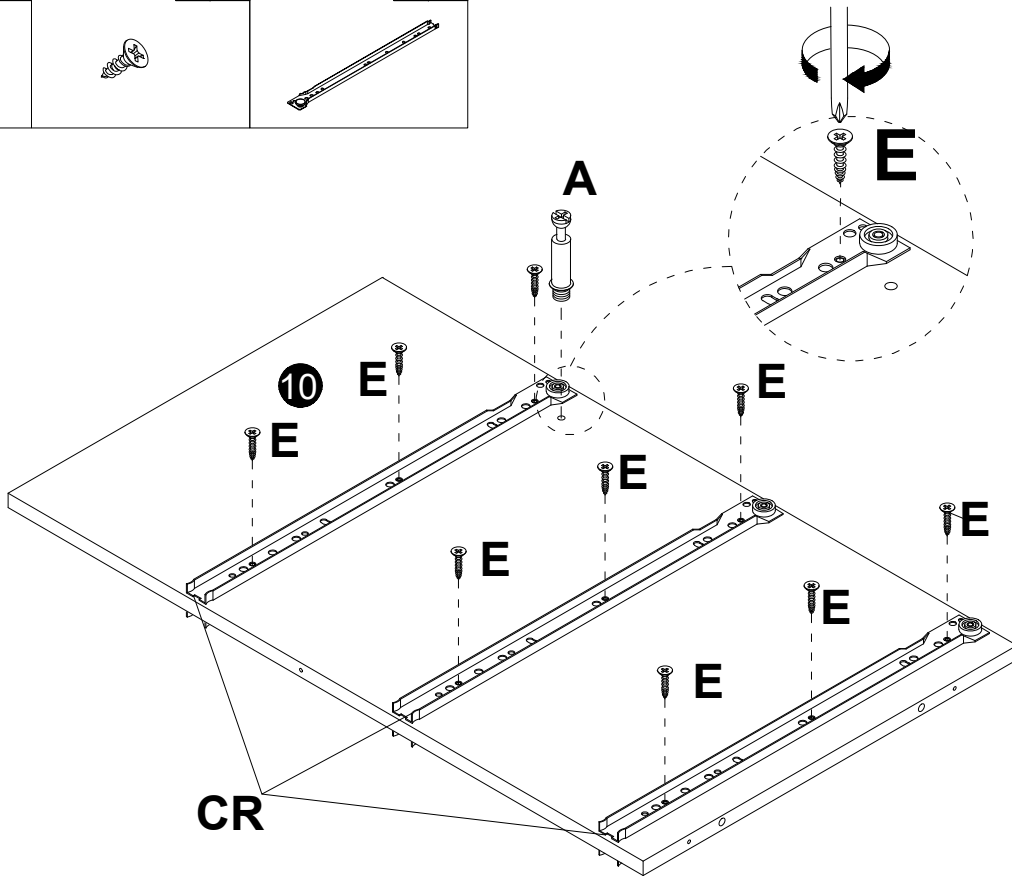
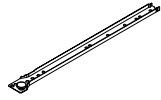
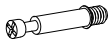

B x3

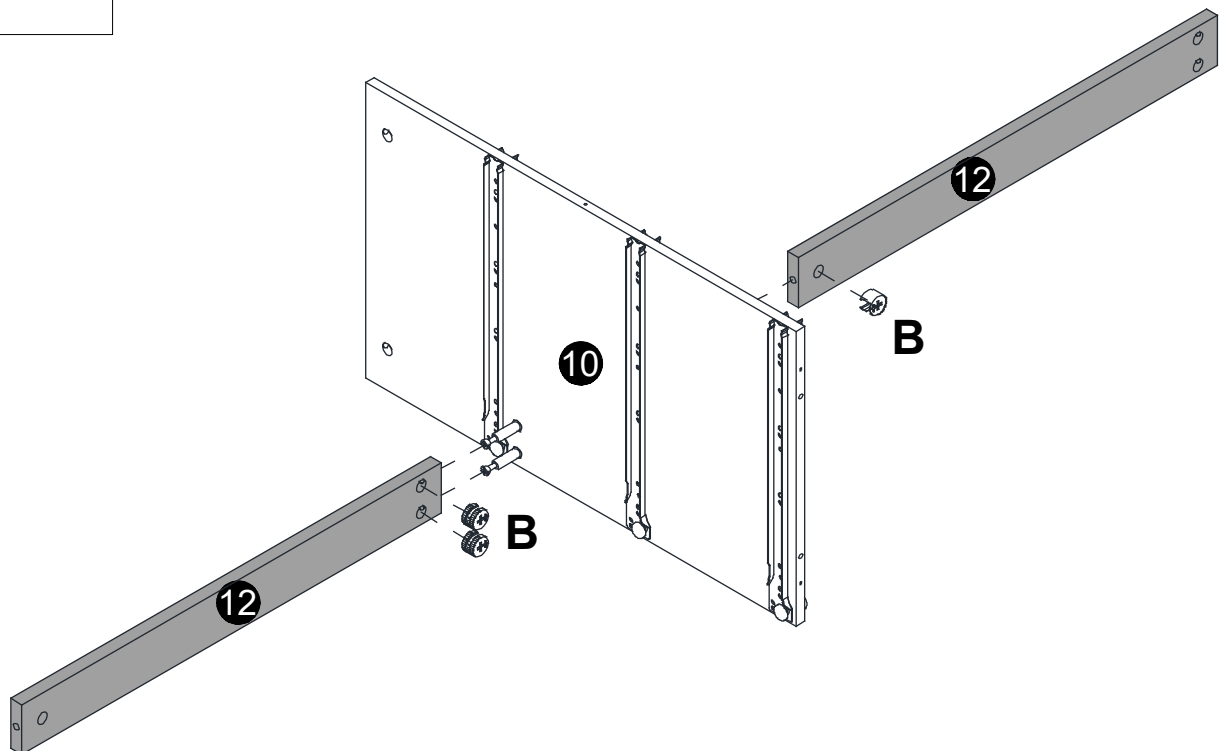

D x1

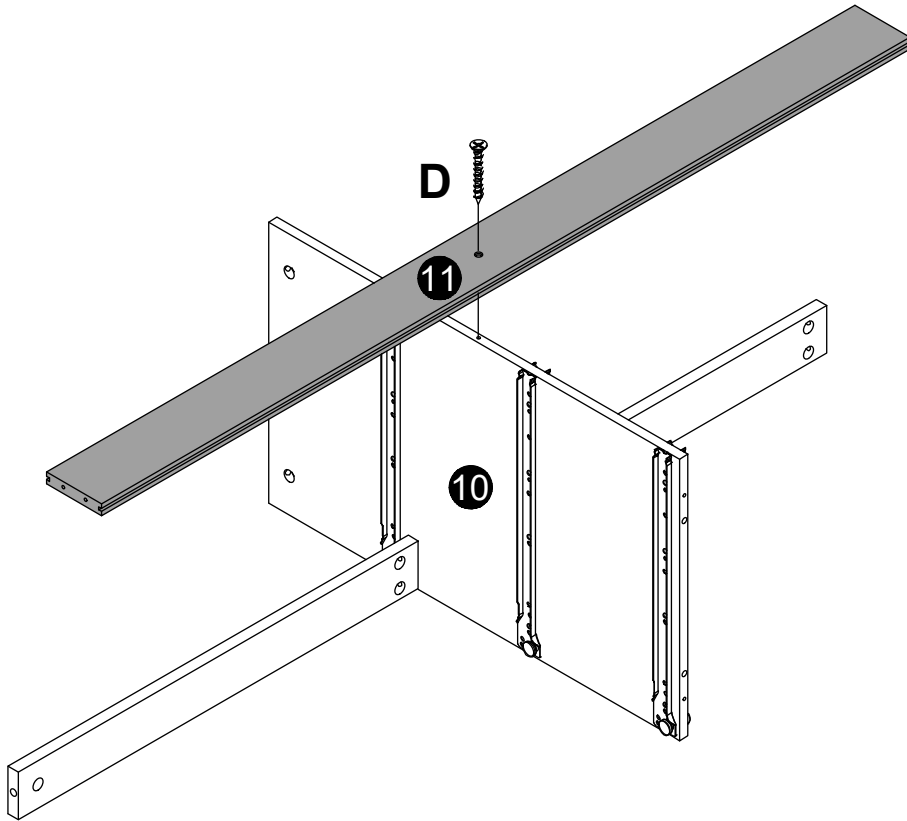

B x3

D x4

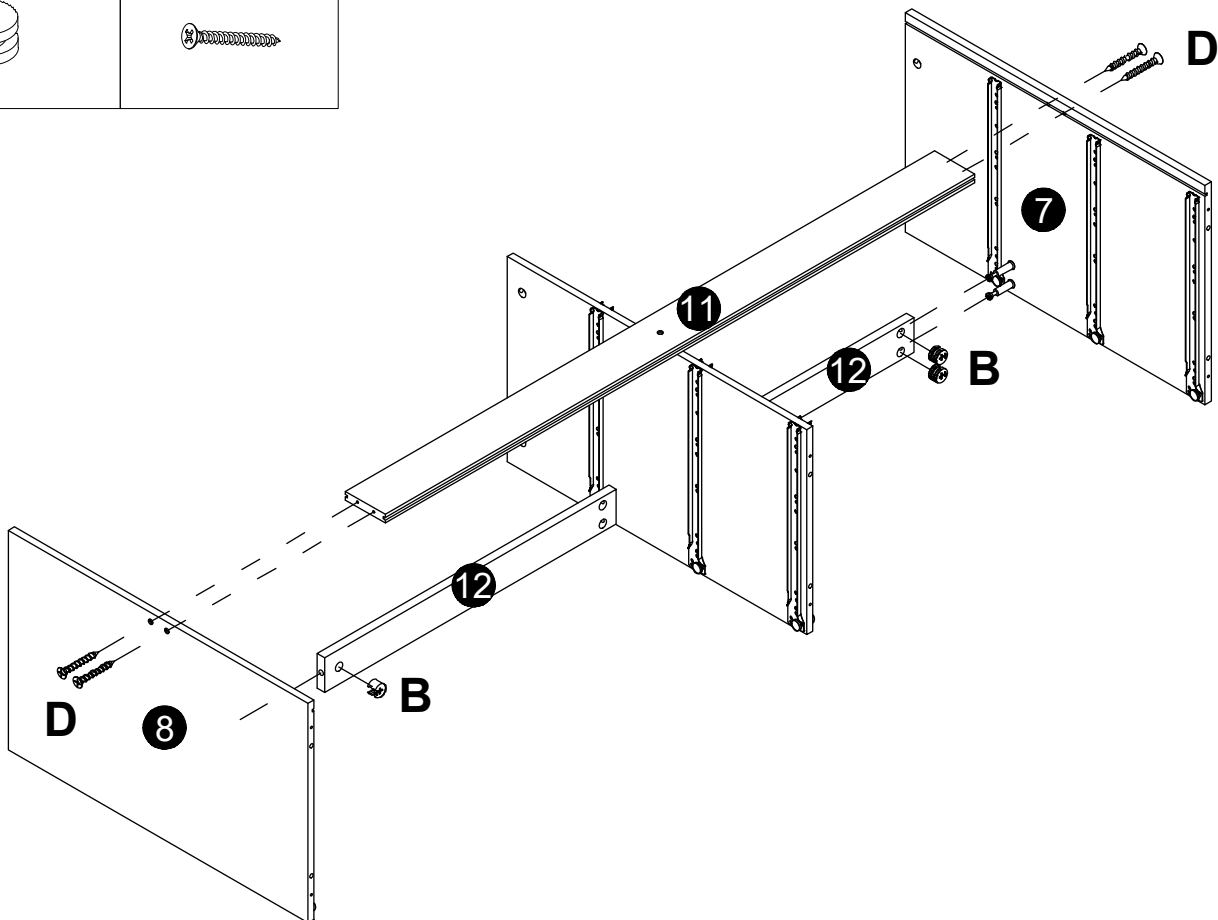
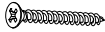

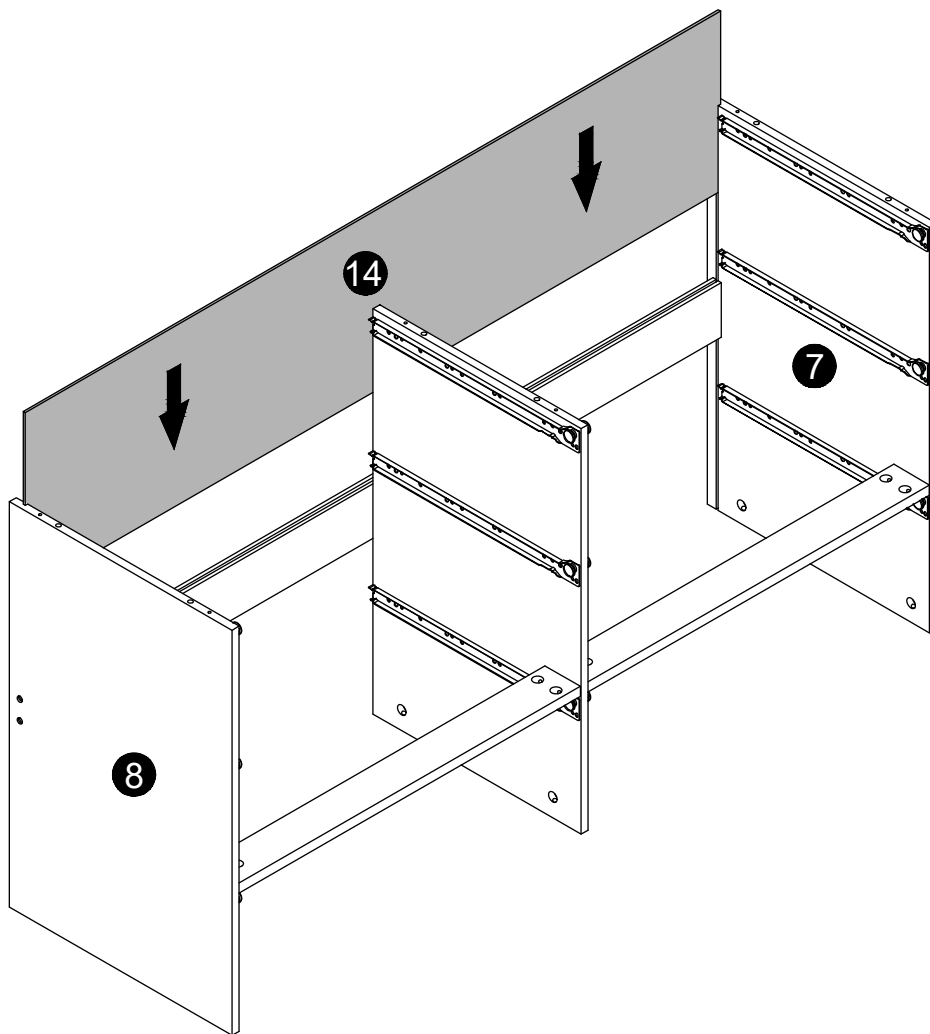

C x6

D x6

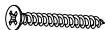

! The backplate slots are rearward

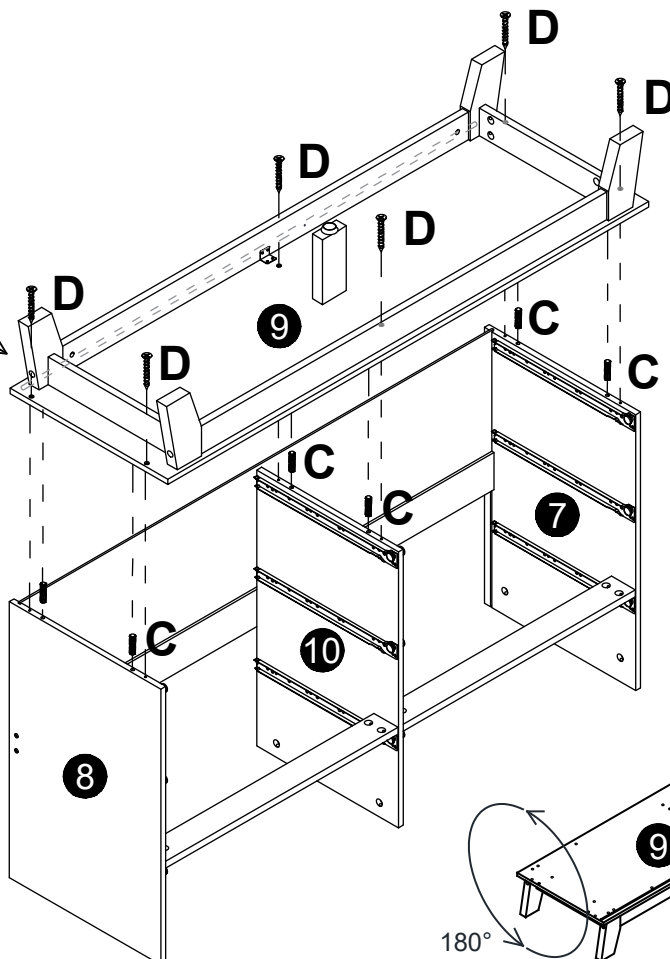
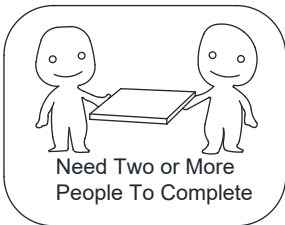

180°

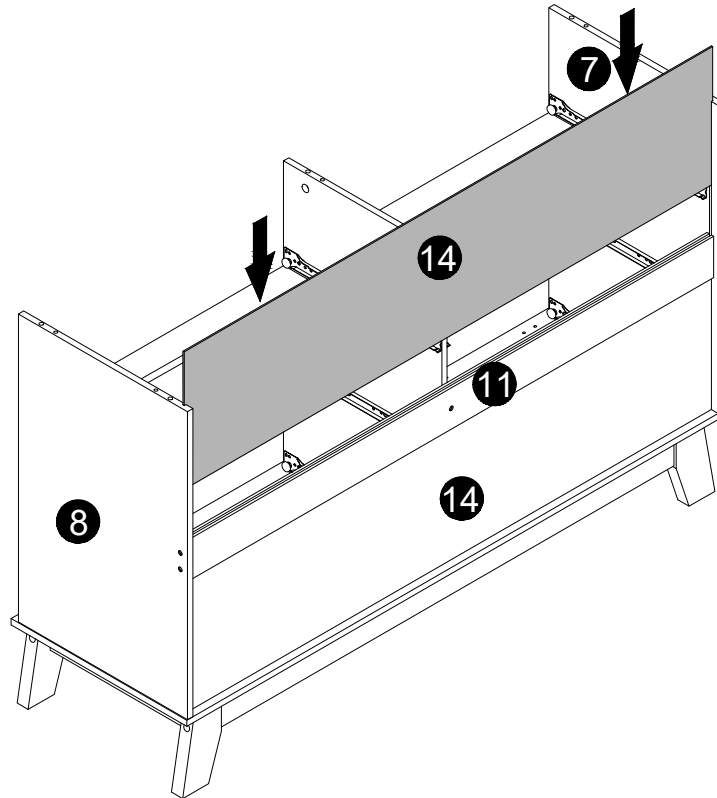

A x6

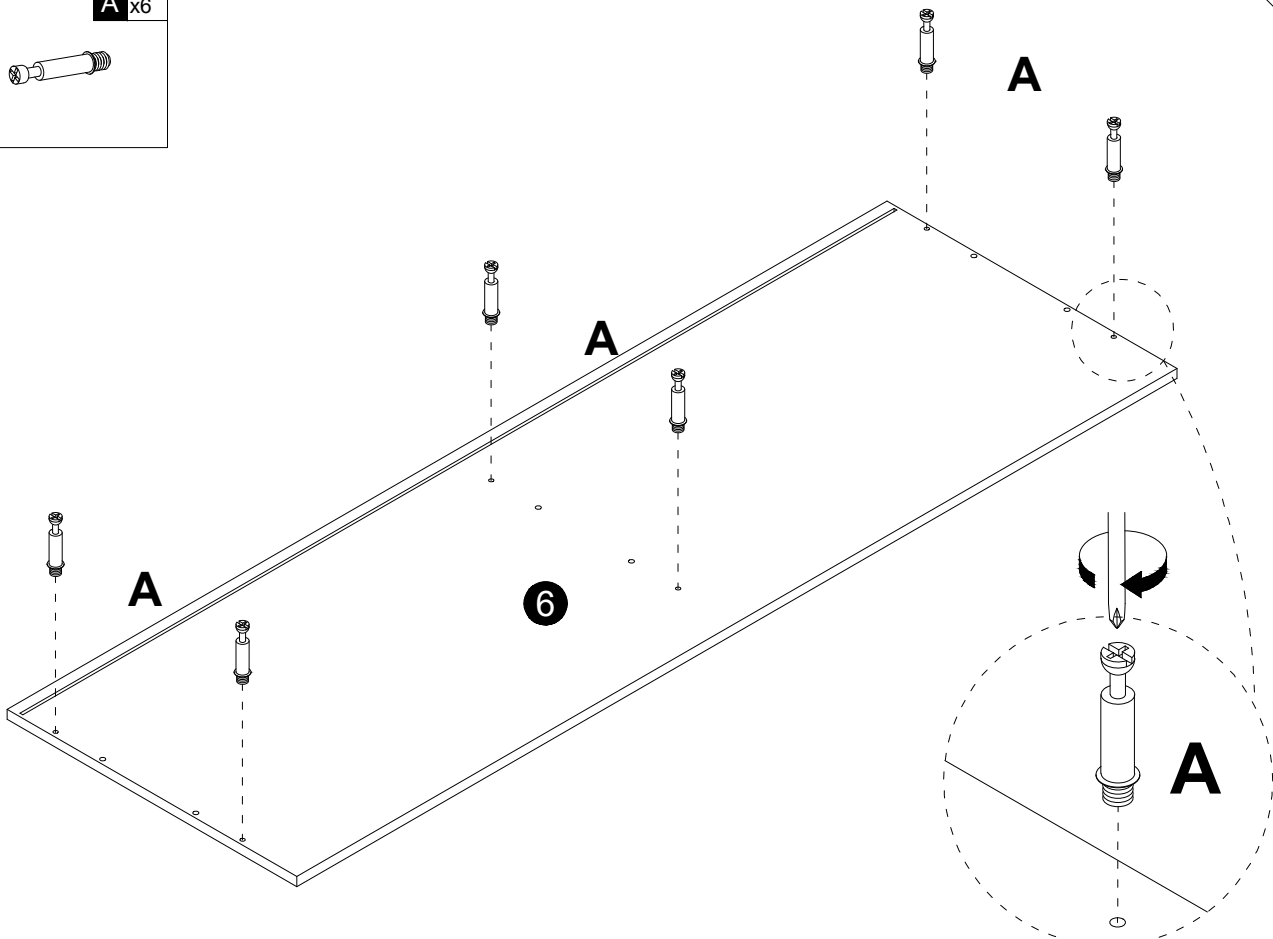
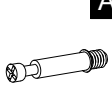

B x6

C x6



! The backplate slots are rearward

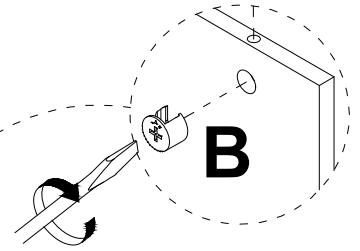
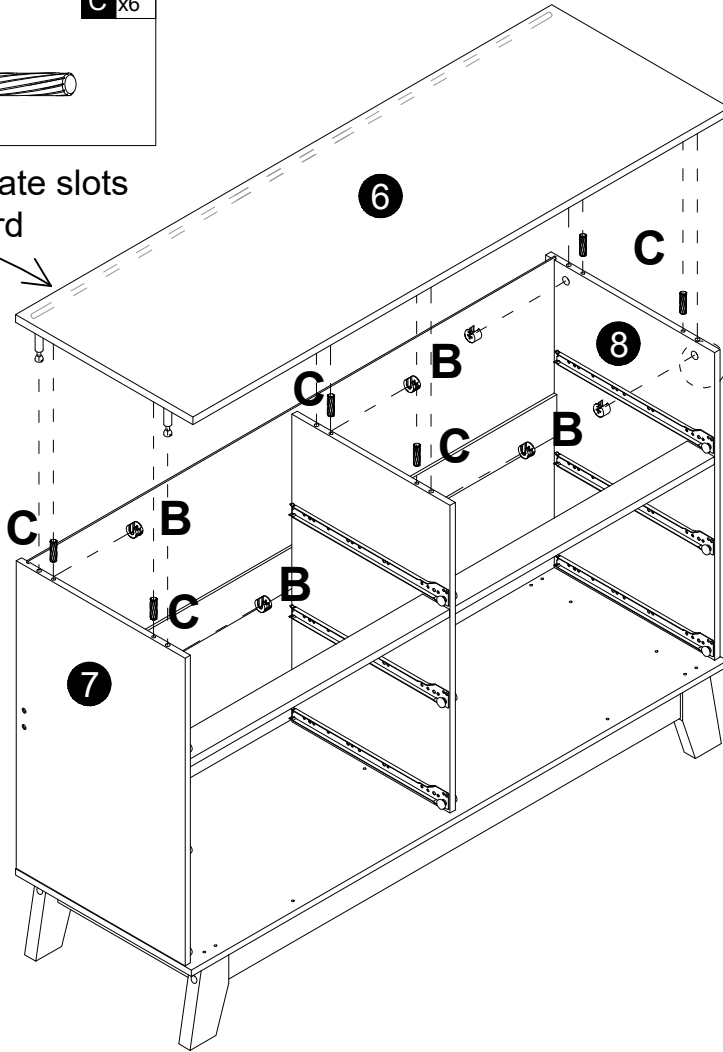

H x10

Q x8

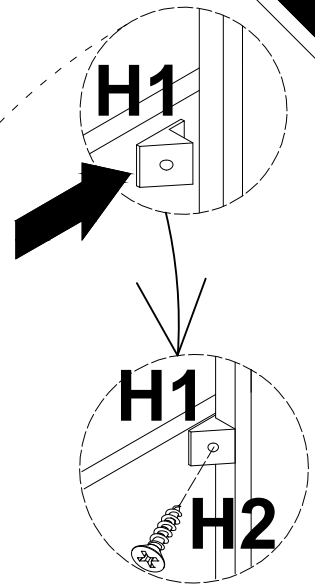
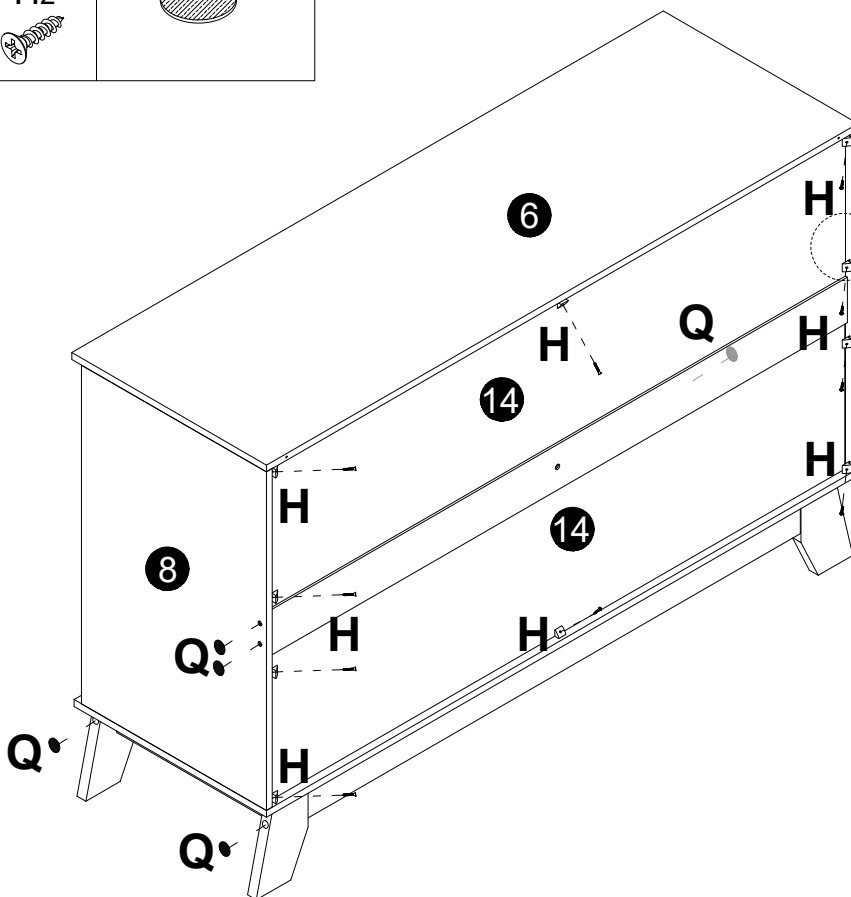
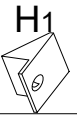

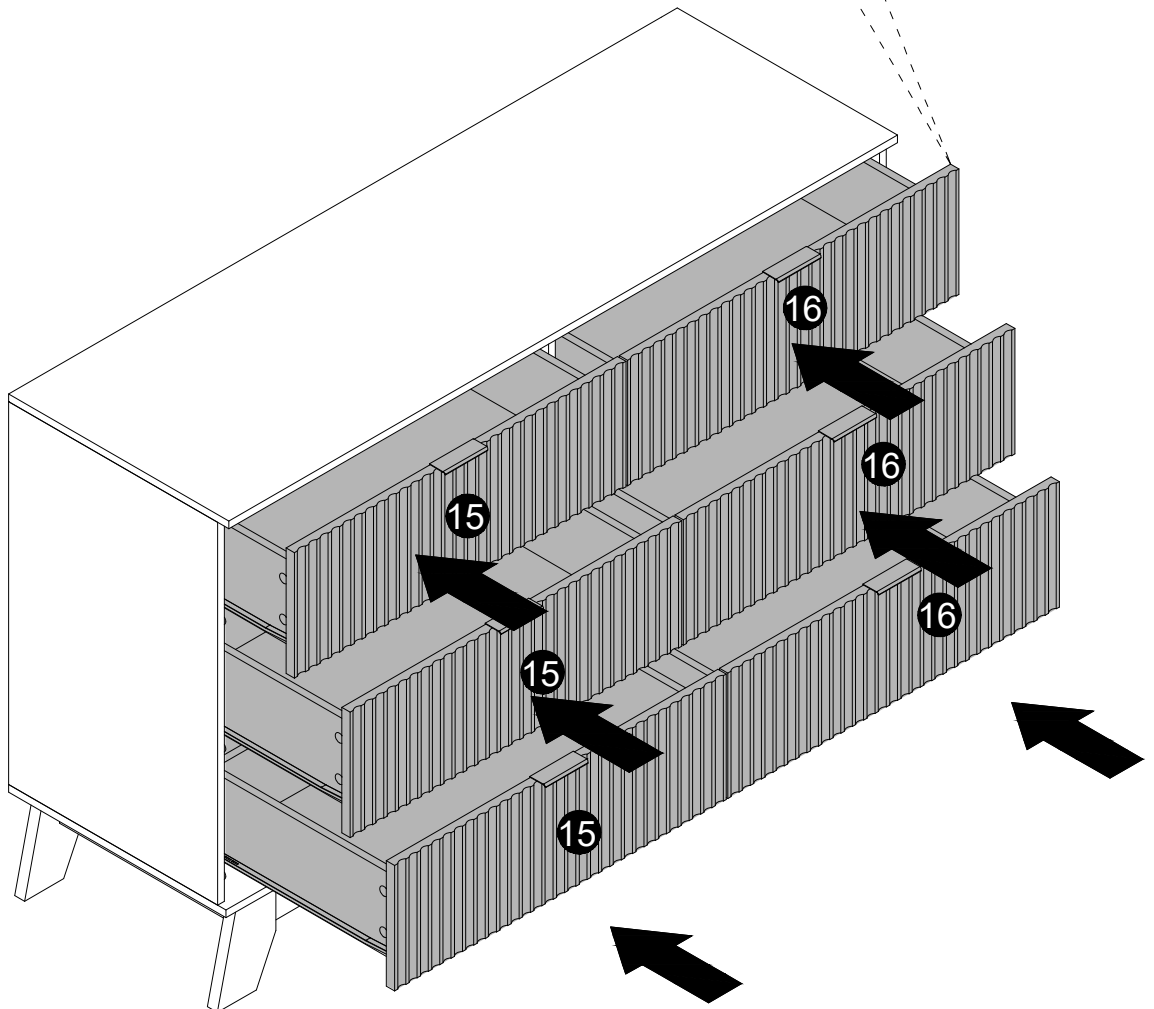
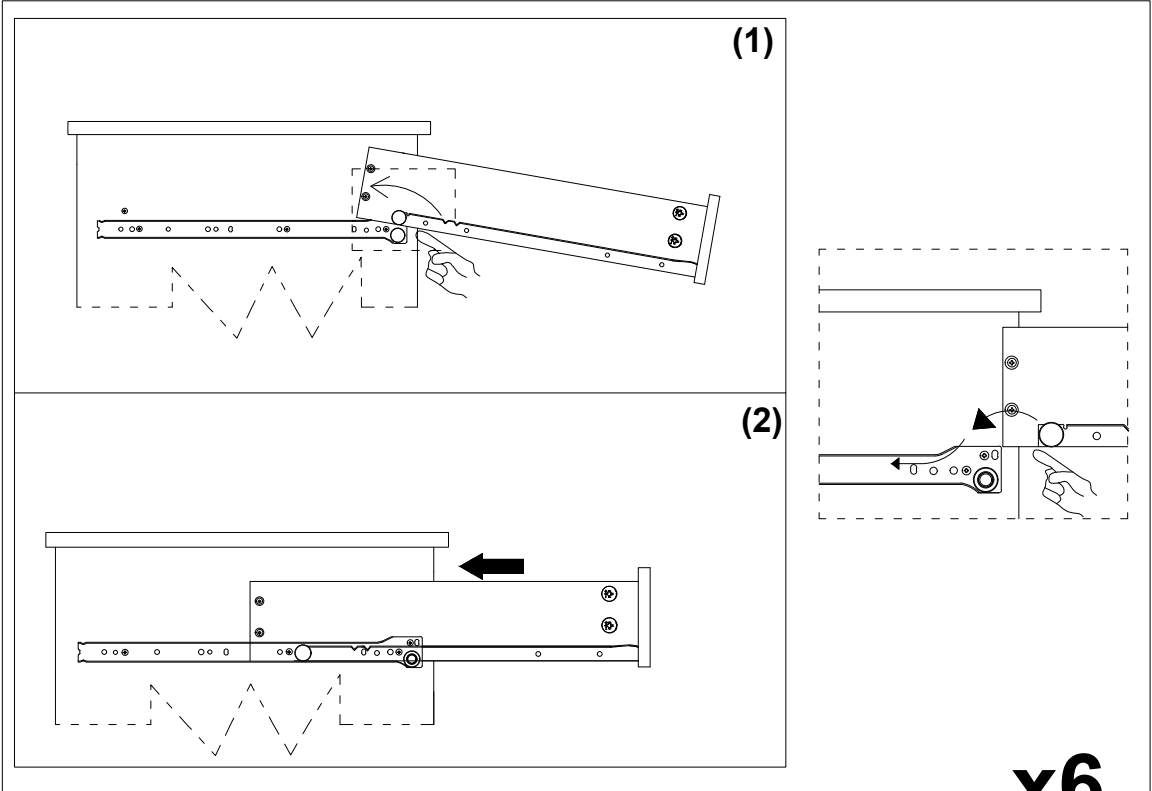

I x2

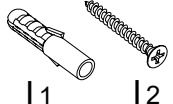

I1

I2

J x2



G x2

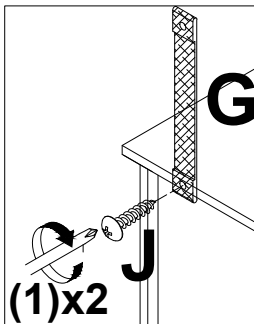

First fix the anti-rewind screw in the reserved hole of the product.

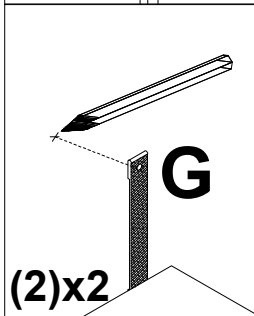

then, use a ruler to measure the approximate height of the product on the wall, and then mark it with a pen.

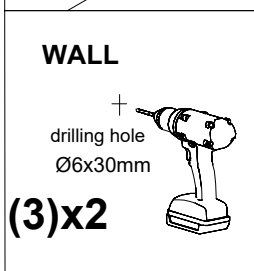

Then use a tape drill to make holes in the wall that are suitable for the product screws.

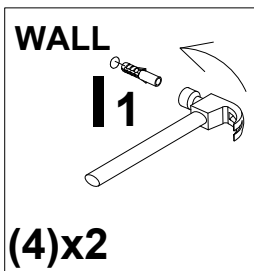

Then, put the expansion bolt into the hole

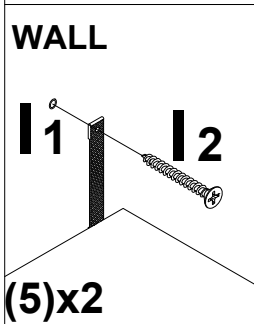

Finally, pass the matching screws through the "anti-rewind" and tighten them to fix them on the wall.

