













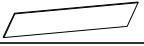













ASSEMBLY INSTRUCTION QUEEN/FULL BED

Caution: Please read instructions thoroughly before unpacking assembly parts. Sharp, exposed staple tips can cause injury, therefore, for your protection, please remove any exposed staples used in packing.

1. We recommend that you should assemble this product with the assistance of another person; this will make assembly easier, and will help to eliminate damage the product or injury to persons during assembly.
2. Be sure to check all packing materials carefully for small parts that may have come loose inside the carton during shipment.
3. Please do not over tighten screws or bolts.
4. Please put all parts on a non-abrasive floor before assembly, and follow the assembly steps to assemble your newly purchased product correctly and efficiently.

| PARTS LIST | | | |
|------------|-------------------------|---|-------|
| NO. | PART DESC. | PART | QTY |
| 1 | HEADBOARD TOP RAIL |  | 1 pc |
| 2 | HEADBOARD SUPPORT RAIL |  | 1 pcs |
| 3 | HEADBOARD VERTICAL RAIL |  | 4 pcs |
| 4 | HEADBOARD CENTER RAIL-1 |  | 1 pc |
| 5 | HEADBOARD CENTER RAIL-2 |  | 1pc |
| 6 | HEADBOARD PANEL |  | 1 pc |
| 7 | HEADBOARD BOTTOM RAIL |  | 1 pc |
| 8 | HEADBOARD LEG LEFT |  | 1 pc |
| 9 | HEADBOARD LEG RIGHT |  | 1 pc |
| 10 | FOOTBOARD TOP RAIL |  | 1 pc |
| 11 | FOOTBOARD PANEL |  | 1 pc |
| 12 | SIDE RAIL LEFT |  | 2 pcs |
| 13 | SIDE RAIL RIGHT |  | 2 pcs |
| 14 | SIDE RAIL LEG |  | 2 pcs |
| 15 | SLAT ROLL |  | 2 pcs |
| 16 | CENTER SLAT |  | 2 pcs |
| 17 | VERTICAL LEG |  | 4 pcs |

| HARDWARE LIST | | | | |
|---------------|---------------------|---|-----------------|--------|
| NO. | HARDWARE DESC. | PART | SIZE | QTY |
| A | MINIFIX - BOLT |  | | 20 pcs |
| B | MINIFIX - CAM |  | 15 MM x 11.5 MM | 20 pcs |
| C | PAN HEAD SCREW |  | M4 x 30MM | 29 pcs |
| D | WOOD DOWEL |  | M8 x 30MM | 4 pcs |
| E | WOOD DOWEL |  | M6 x 20MM | 2 pc |
| F | SINGLE CORNER BLOCK |  | | 6 pcs |
| G | TAPPING SCREW |  | M3 x 20MM | 6 pcs |
| H | JCBC SCREW |  | M6 x 35MM | 16 pcs |
| I | SPRING WASHER |  | M8 | 16 pcs |
| J | FLAT WASHER |  | M8 | 16 pcs |
| K | ALLEN KEY |  | M4 | 1 pc |

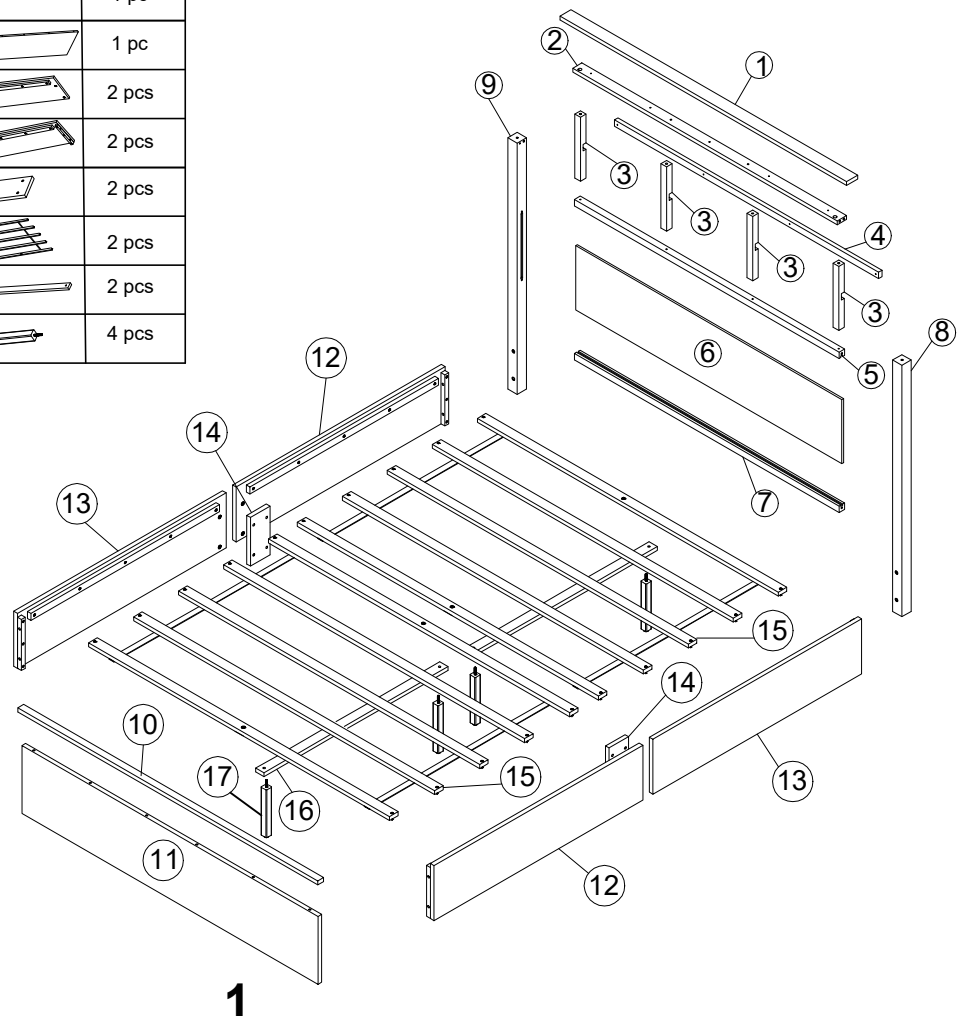

ASSEMBLY INSTRUCTION QUEEN/FULL BED

STEP
1

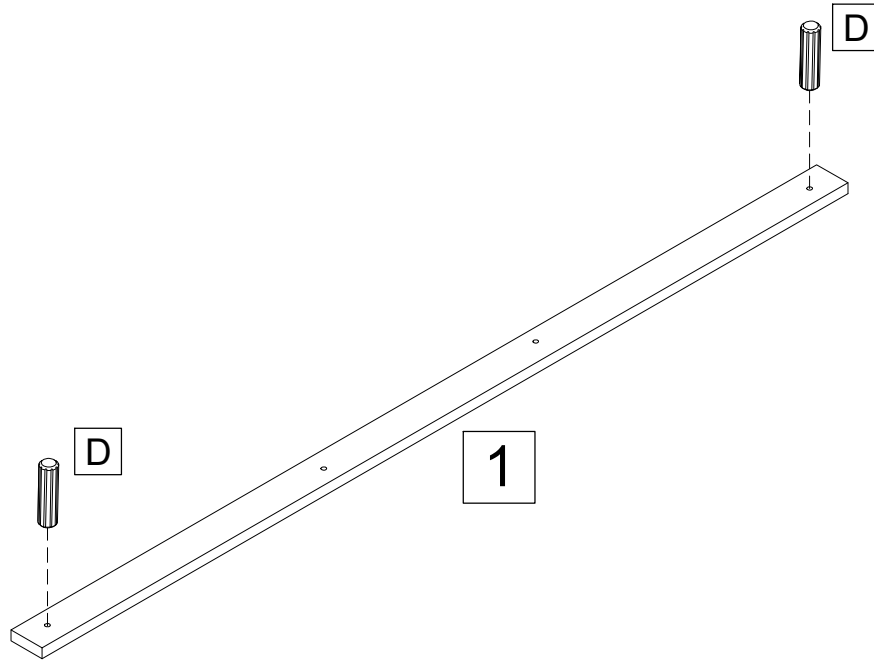
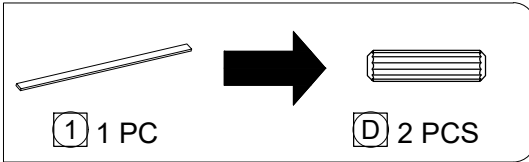

STEP
2

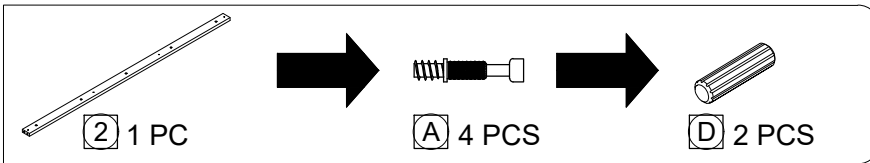

 SCREWDRIVER
REQUIRED

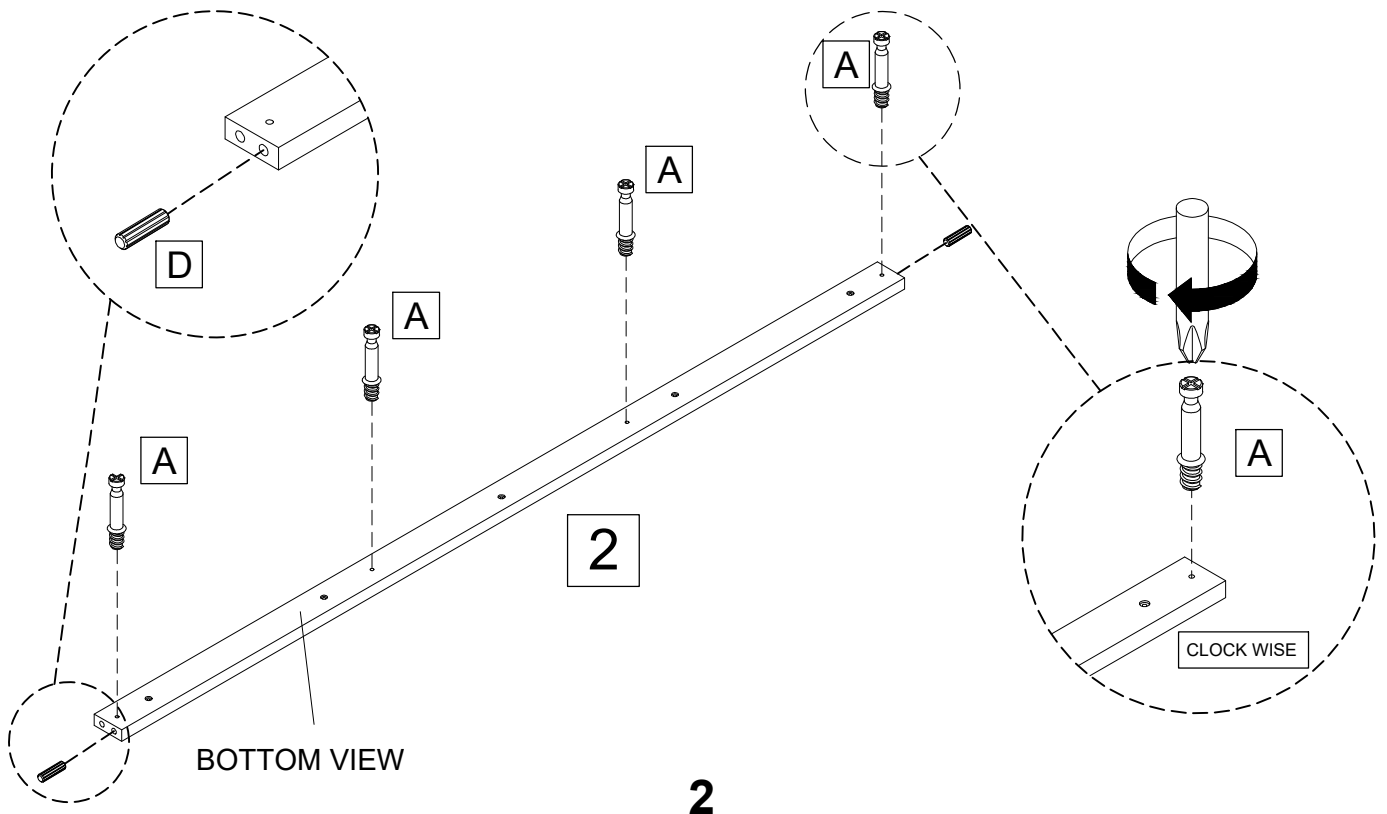

ASSEMBLY INSTRUCTION QUEEN/FULL BED

STEP
3

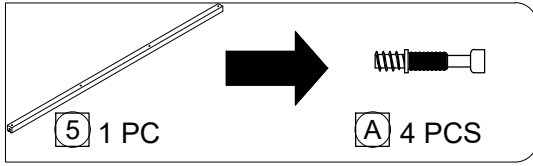

SCREWDRIVER
REQUIRED

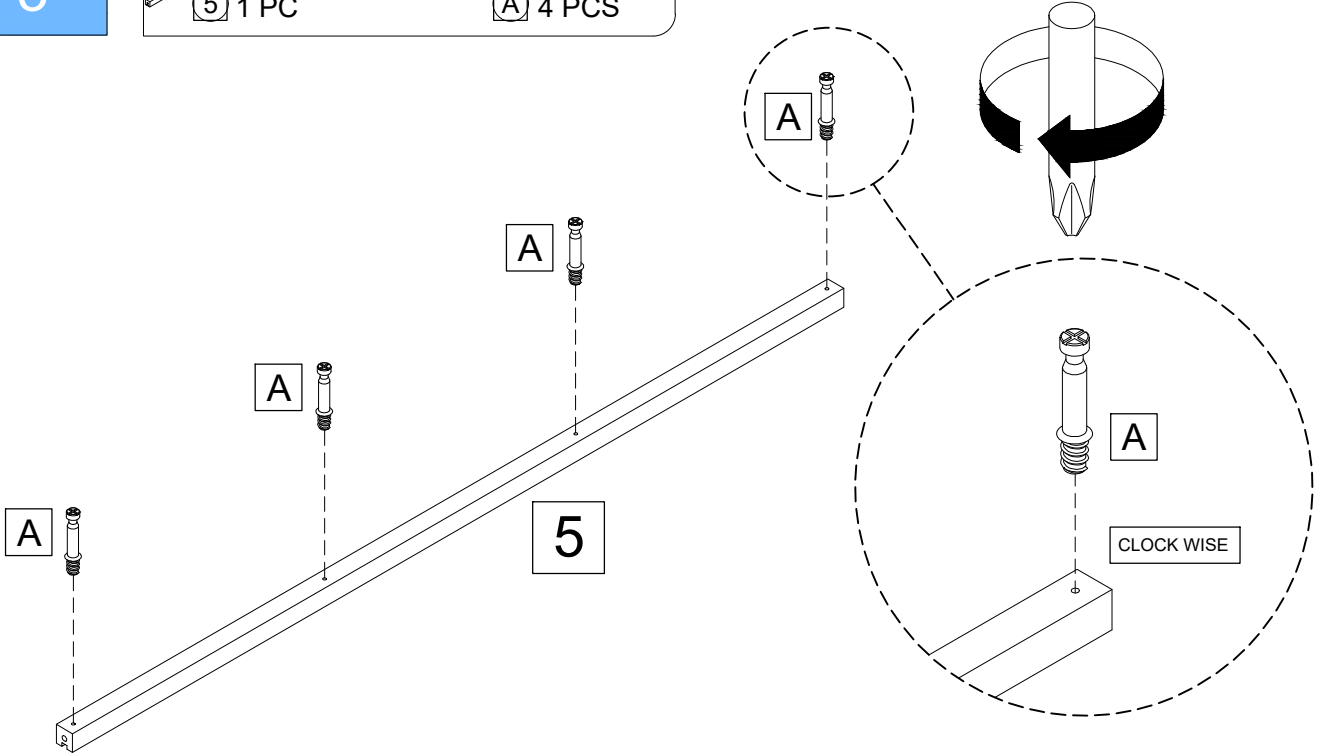

STEP
4

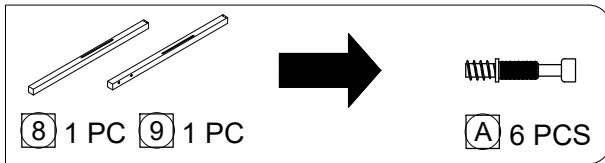

SCREWDRIVER
REQUIRED

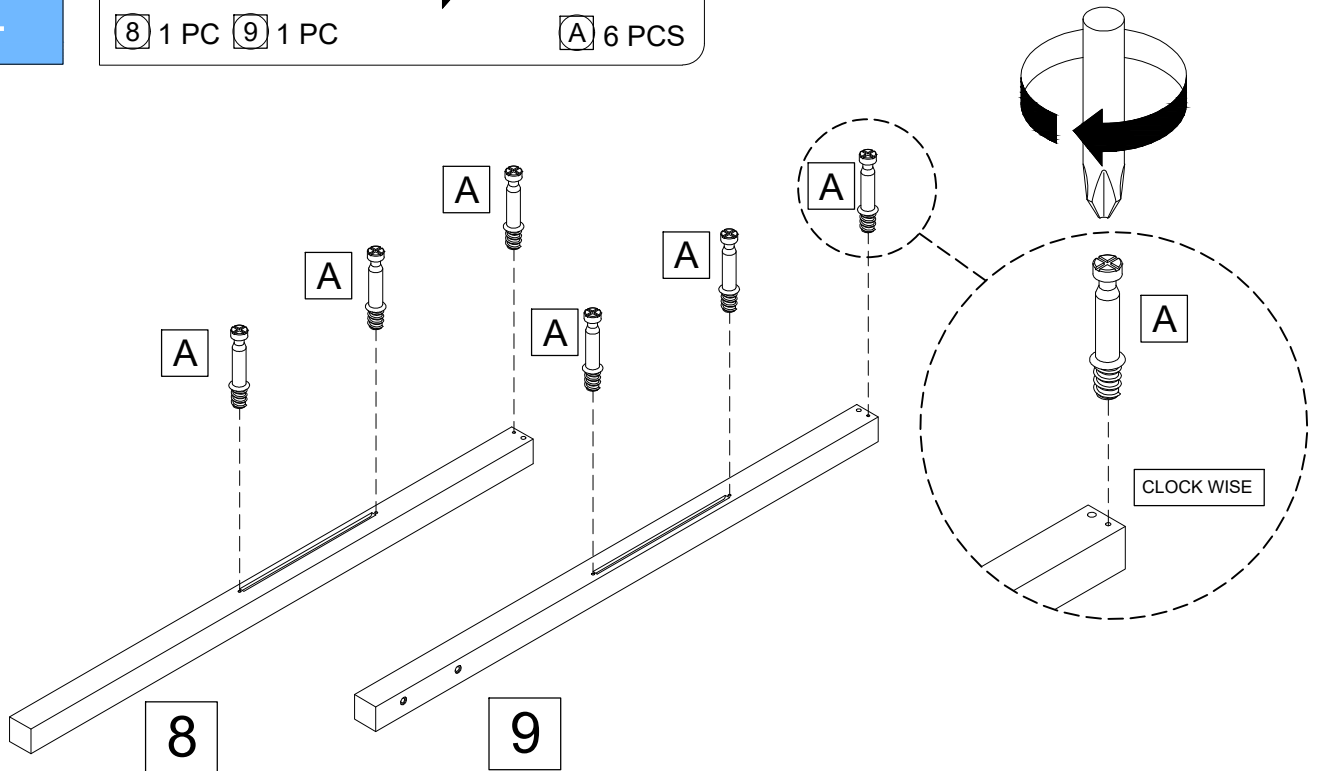

ASSEMBLY INSTRUCTION QUEEN/FULL BED

STEP
5

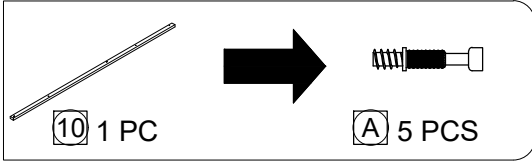

SCREWDRIVER
REQUIRED

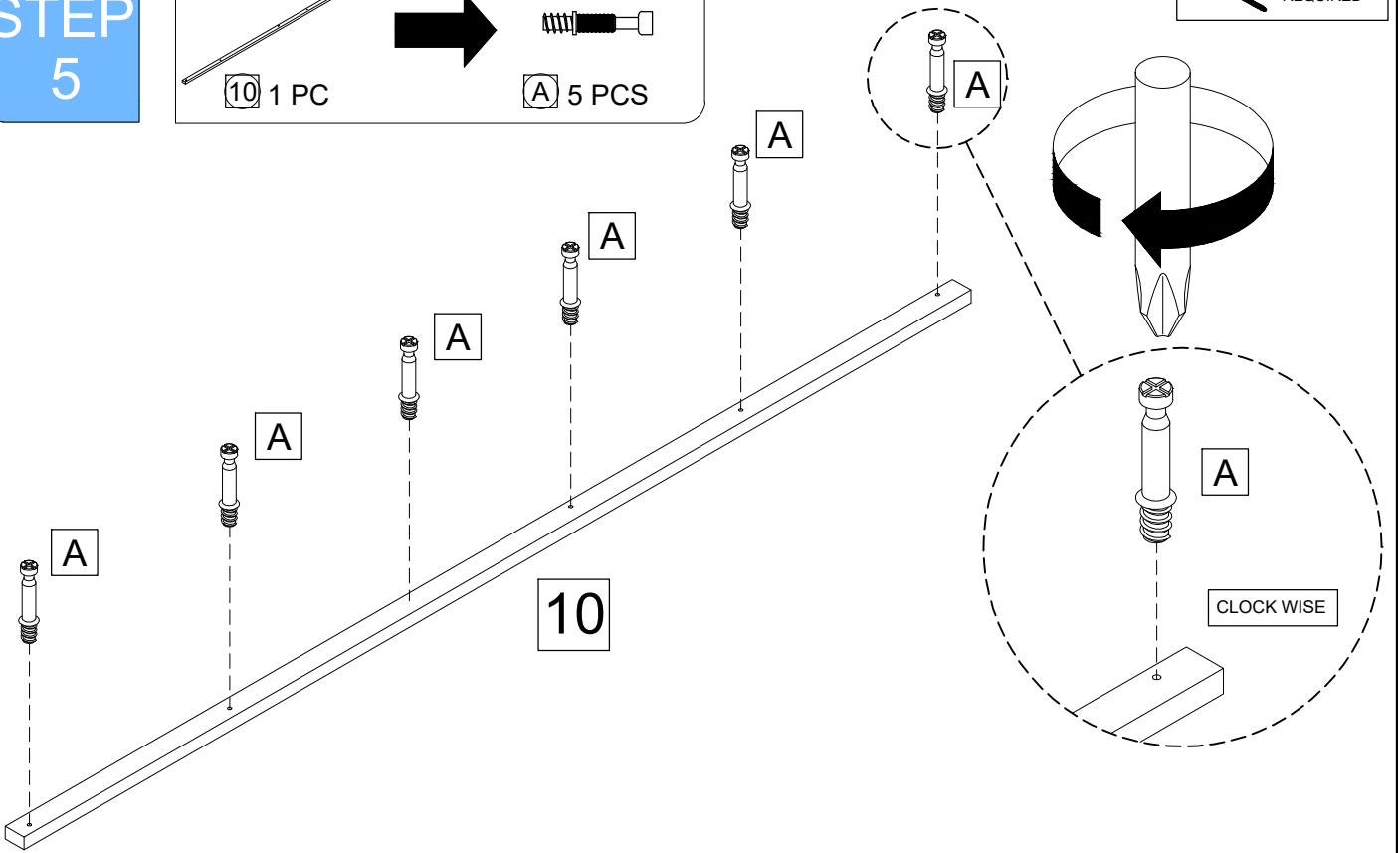

STEP
6

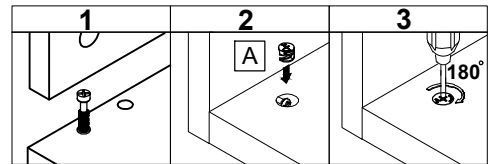
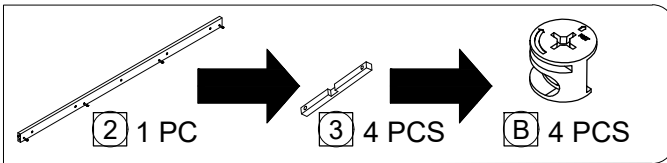

SCREWDRIVER
REQUIRED

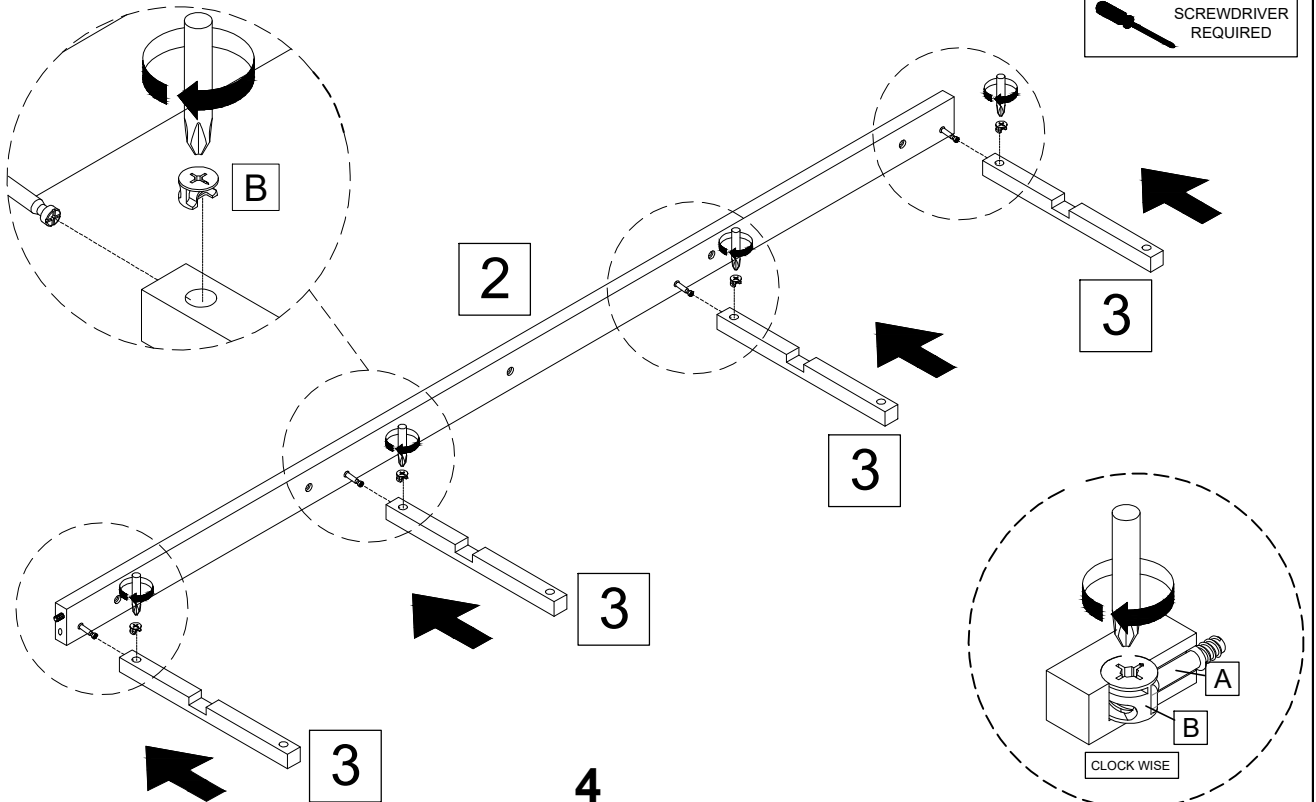

ASSEMBLY INSTRUCTION QUEEN/FULL BED

STEP
7

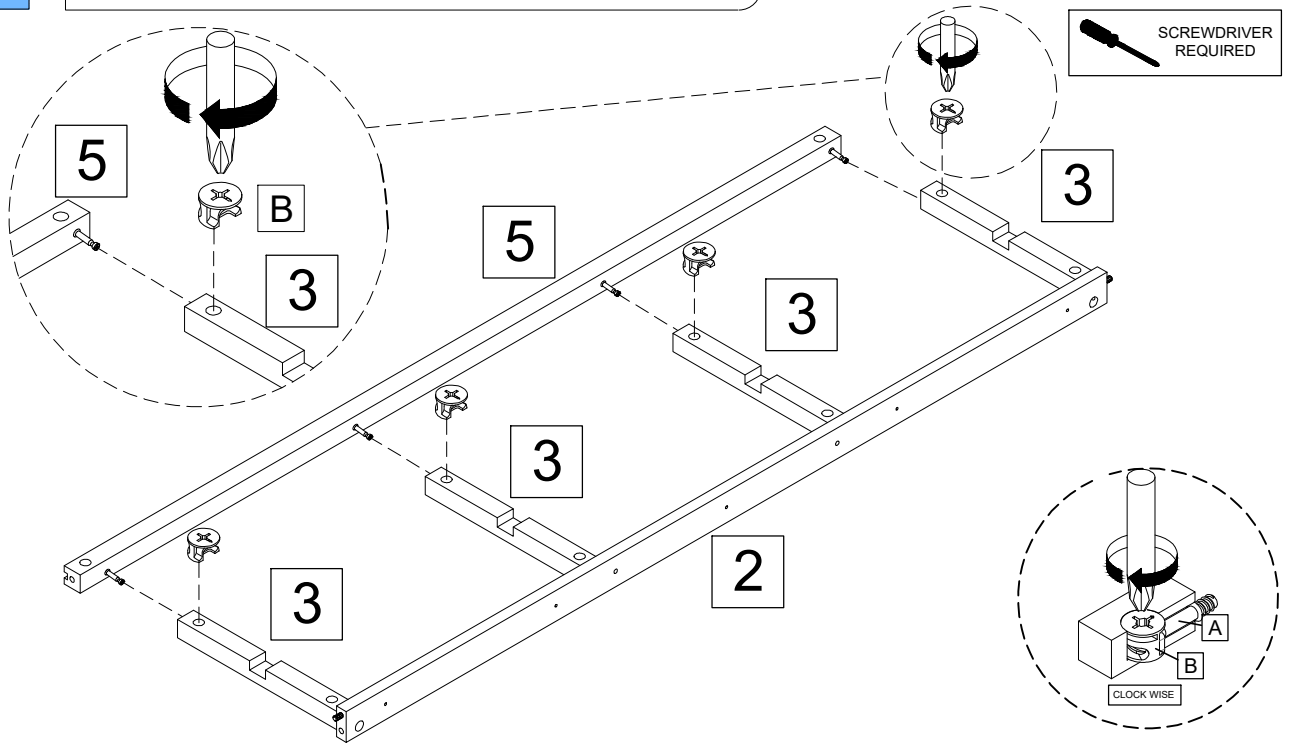
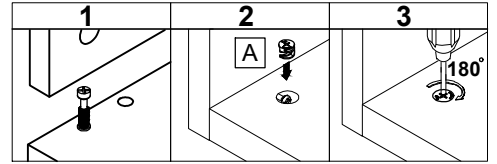
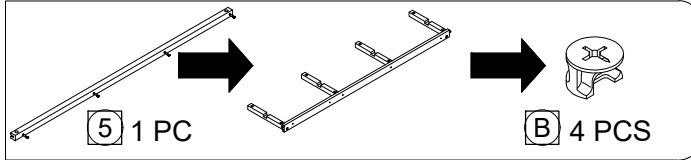

STEP
8

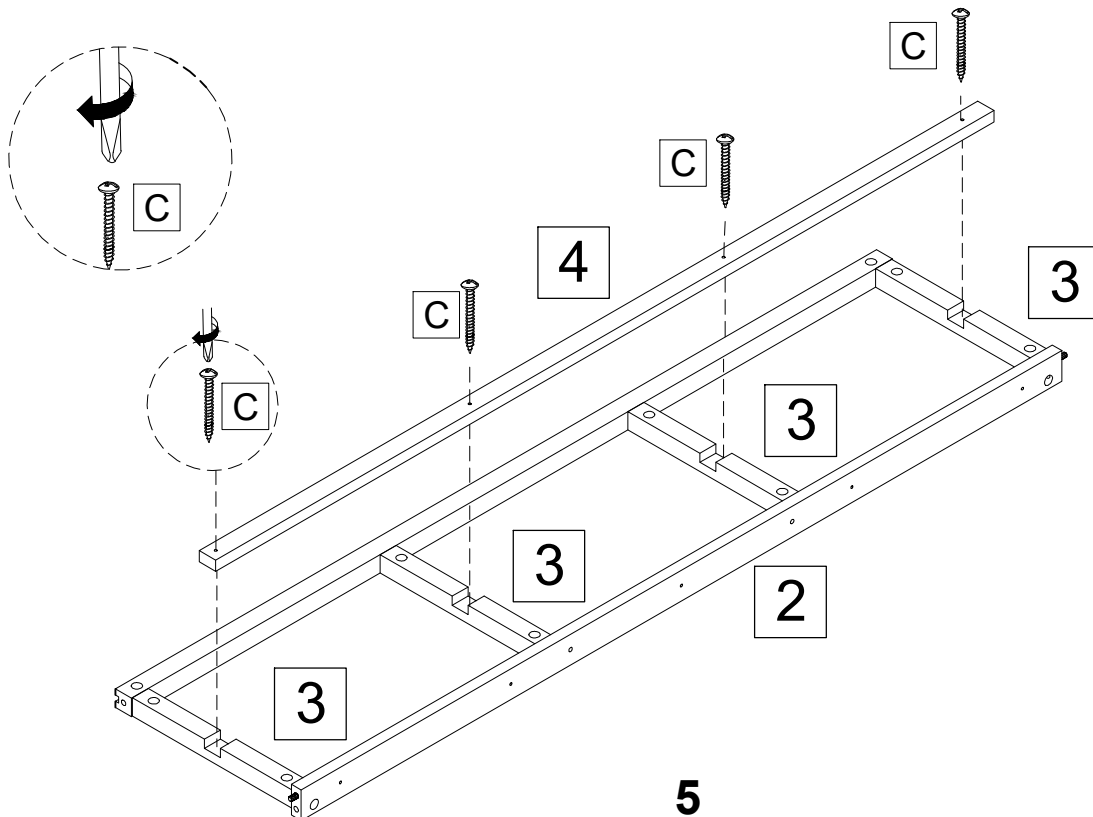
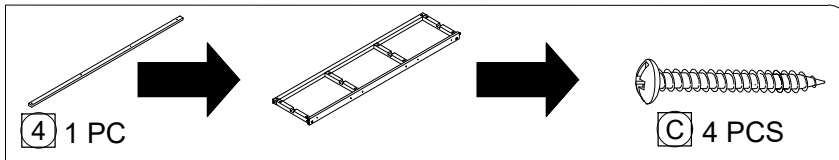

ASSEMBLY INSTRUCTION QUEEN/FULL BED

STEP
9

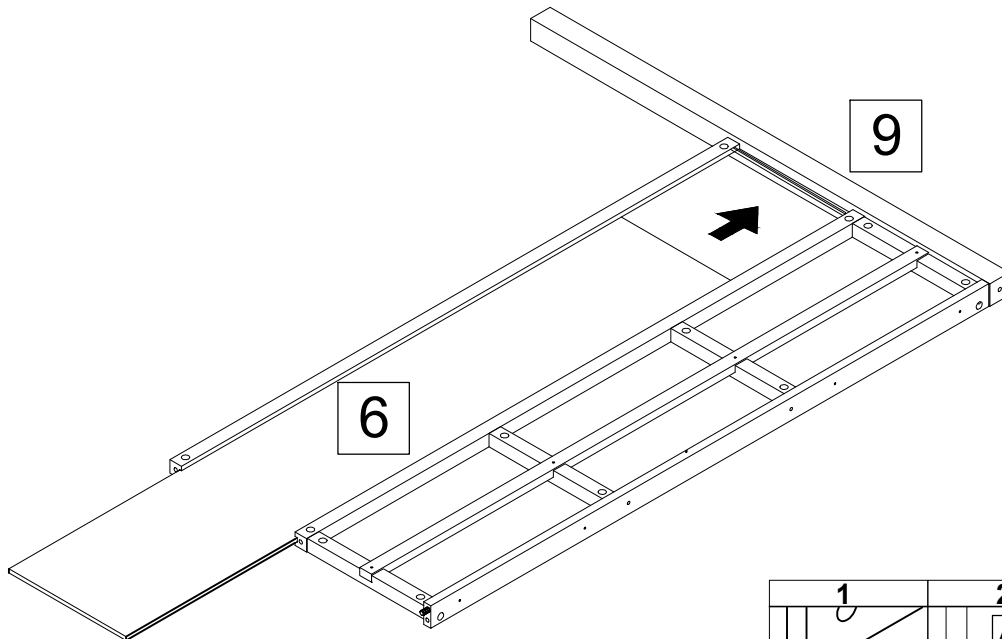
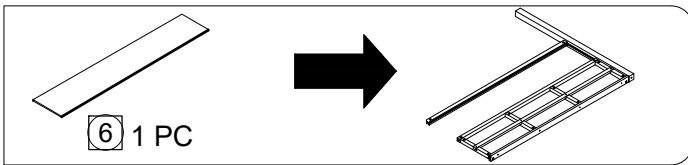
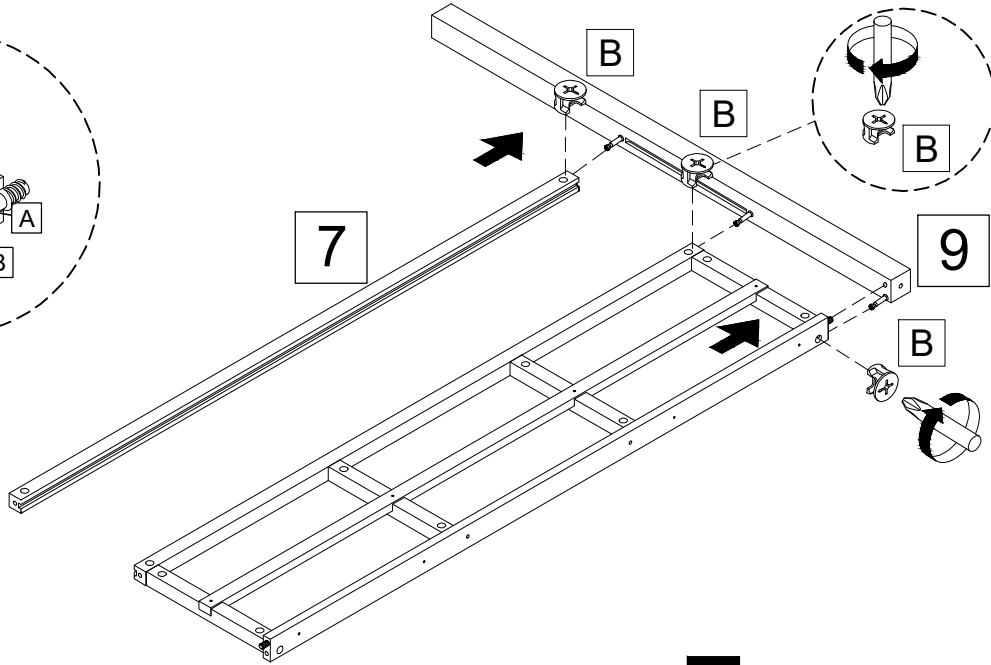
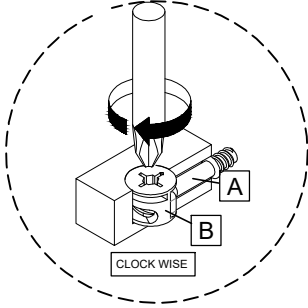
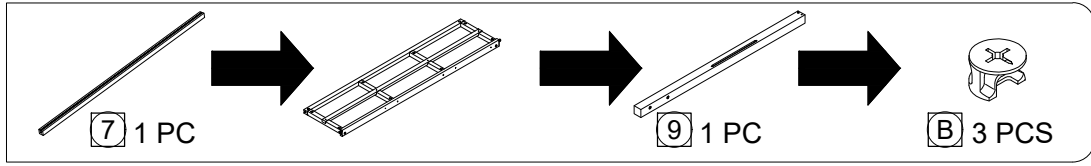

 SCREWDRIVER
REQUIRED

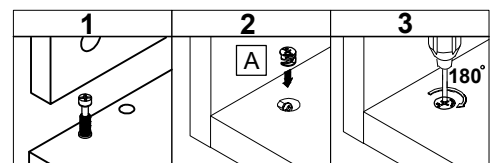

ASSEMBLY INSTRUCTION QUEEN/FULL BED

STEP
12

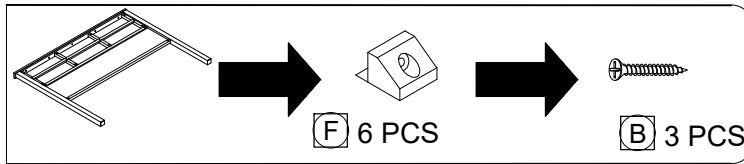

SCREWDRIVER
REQUIRED

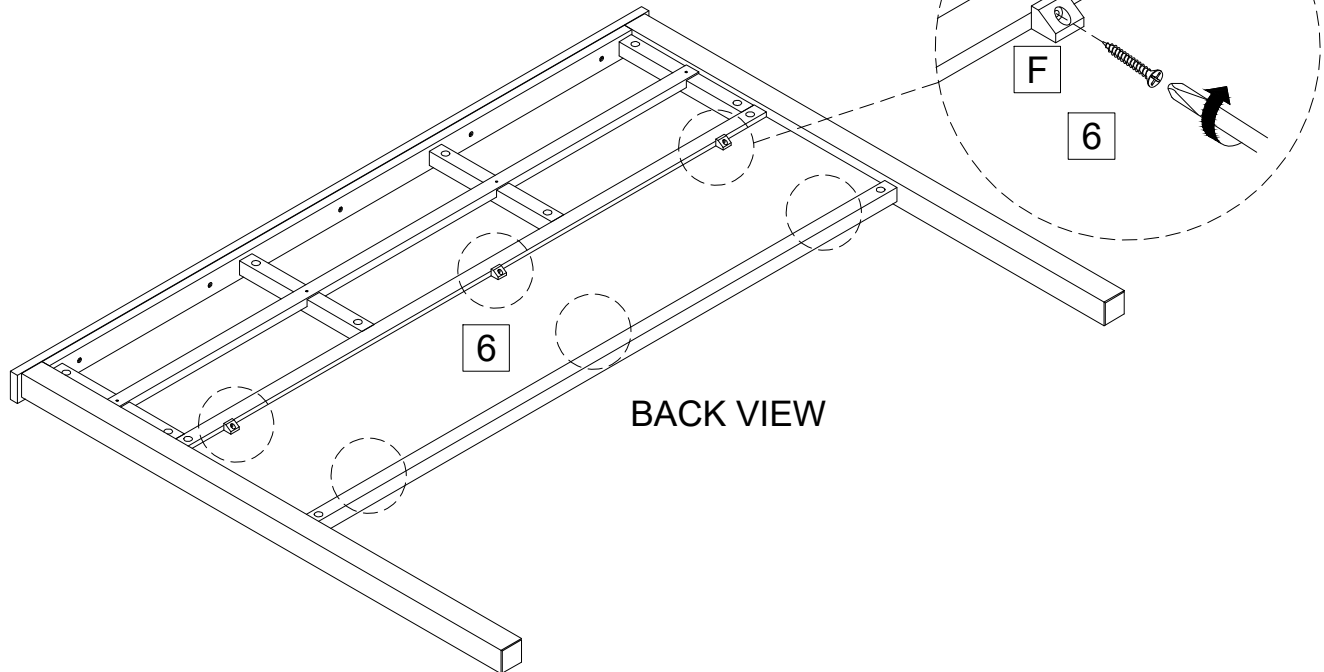

BACK VIEW

STEP
13

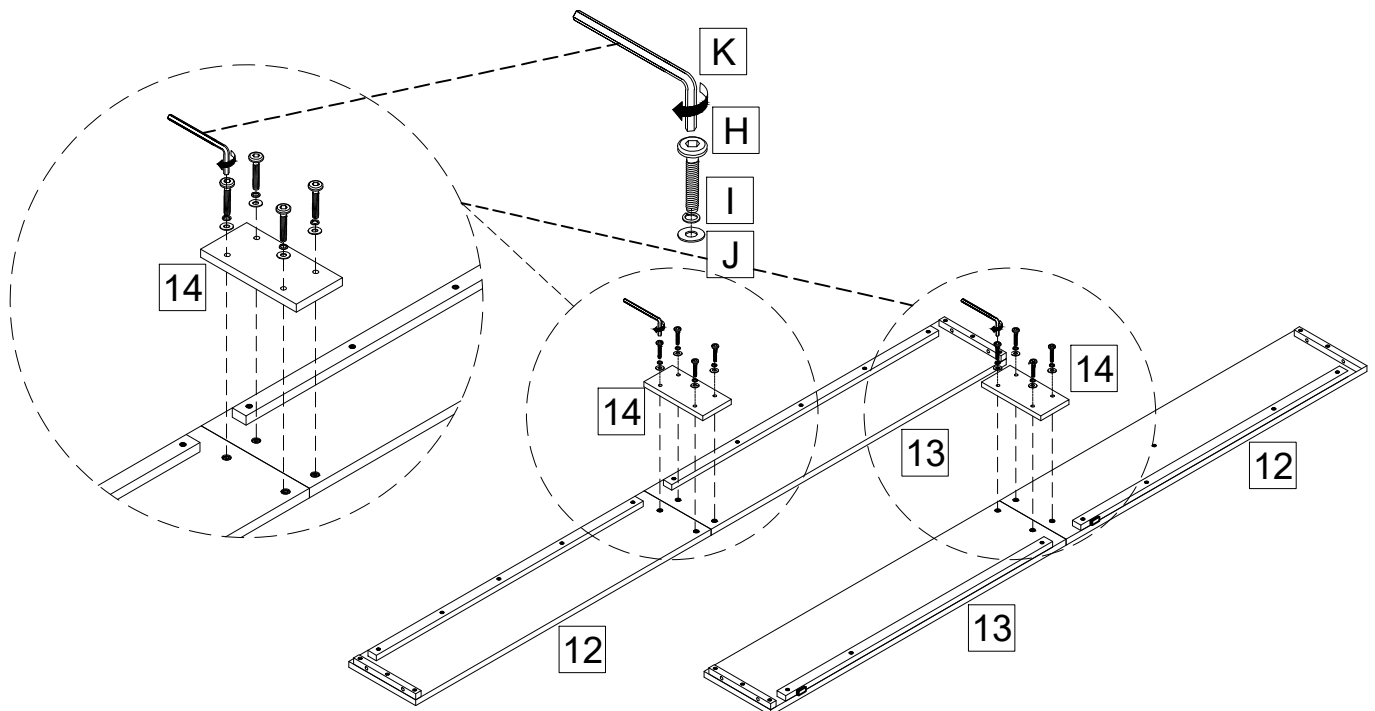
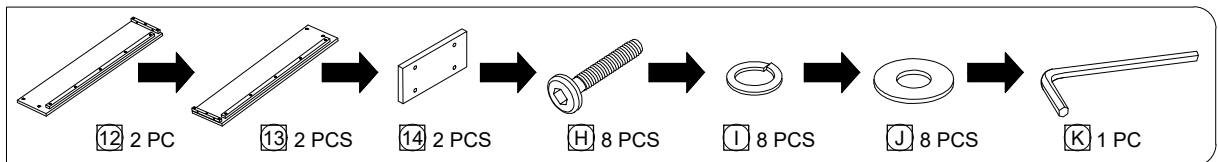

ASSEMBLY INSTRUCTION QUEEN/FULL BED

STEP 14

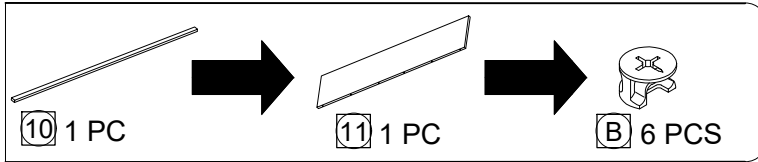

SCREWDRIVER
REQUIRED

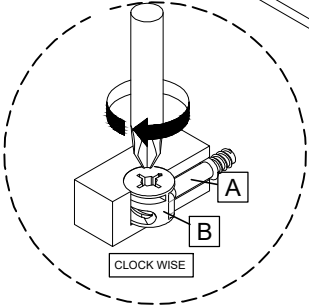
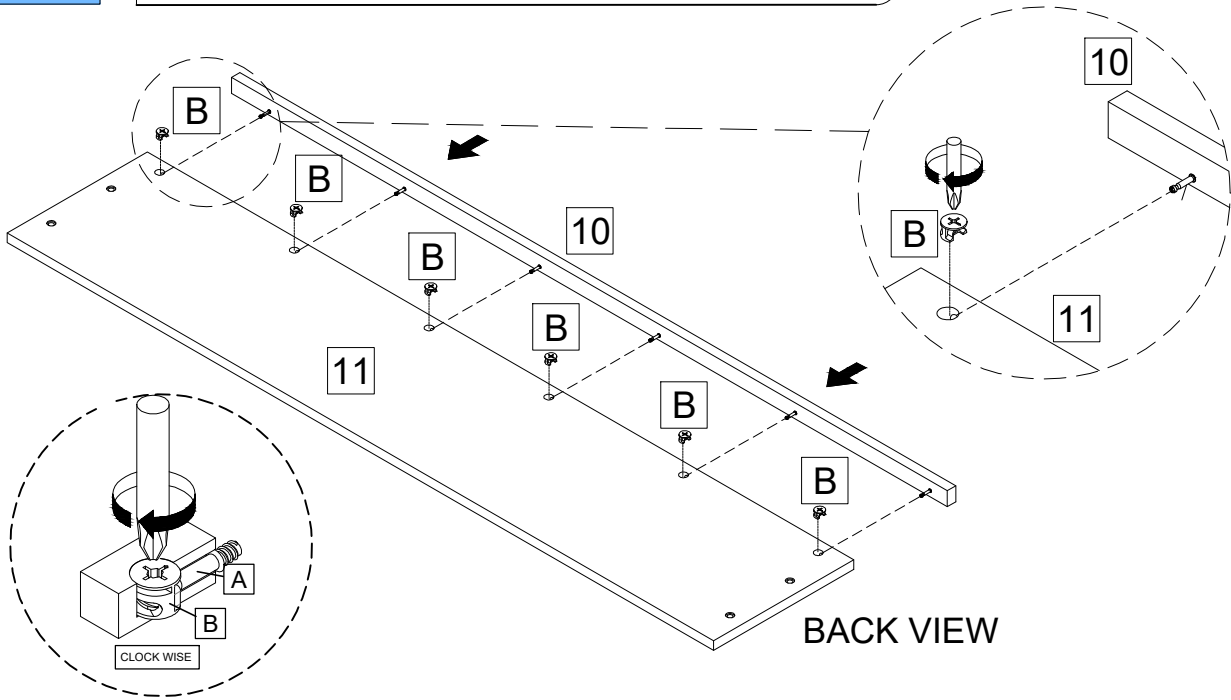

STEP 15

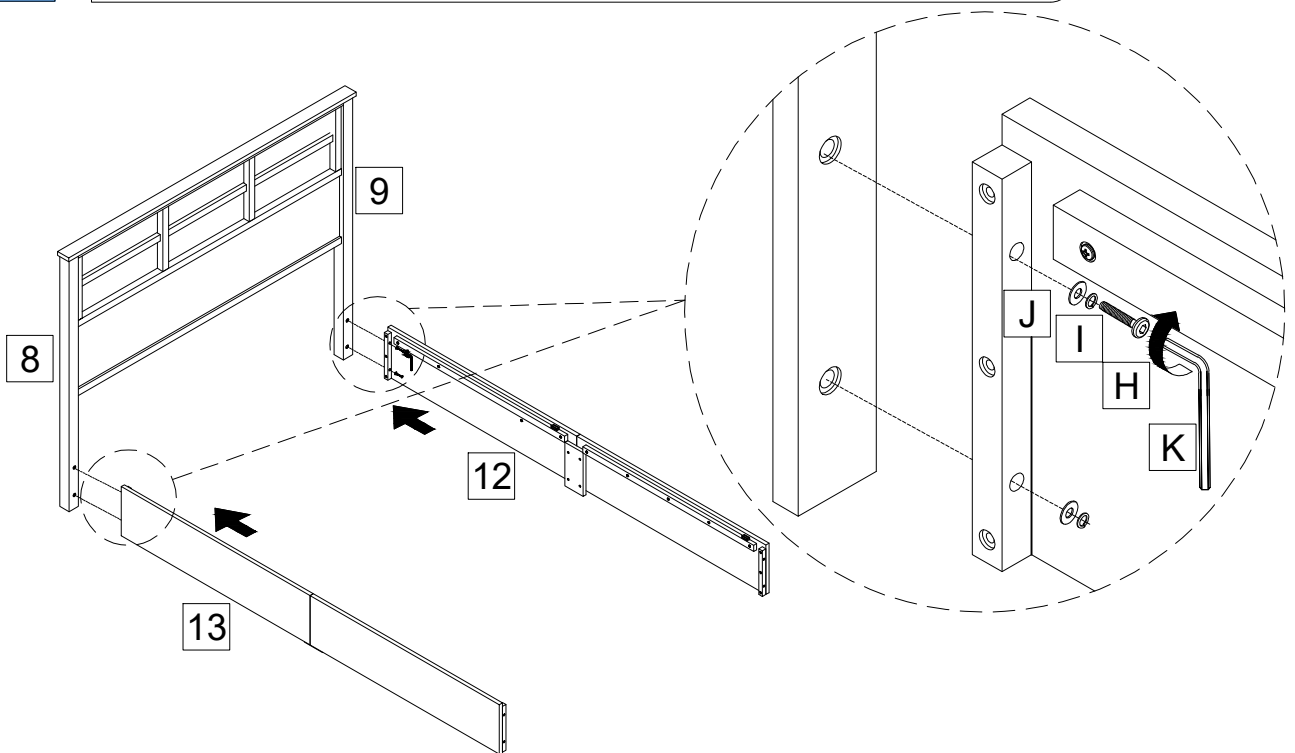
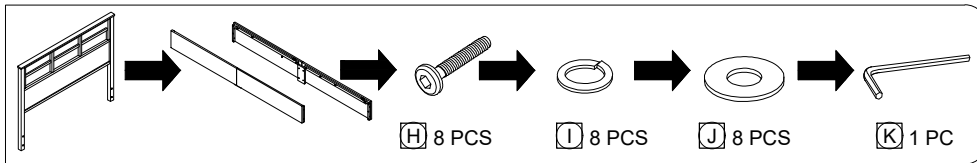

ASSEMBLY INSTRUCTION QUEEN/FULL BED

STEP 16

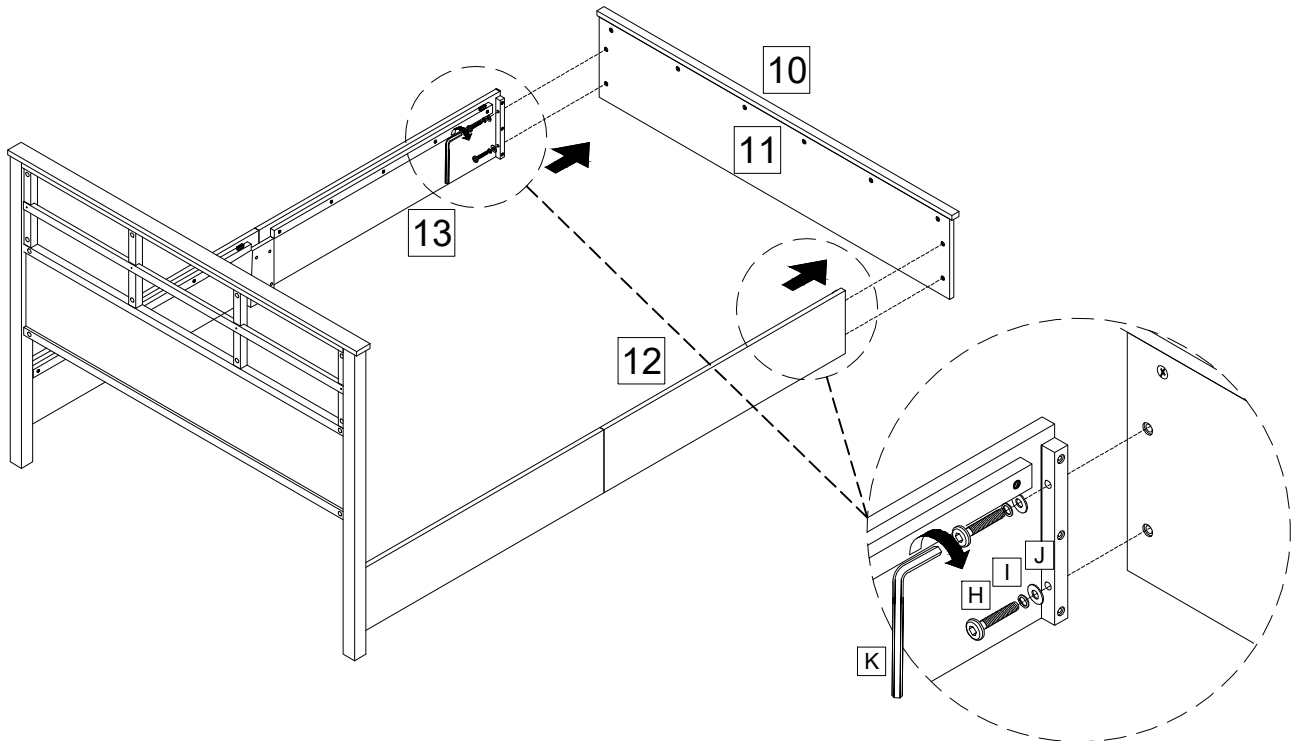
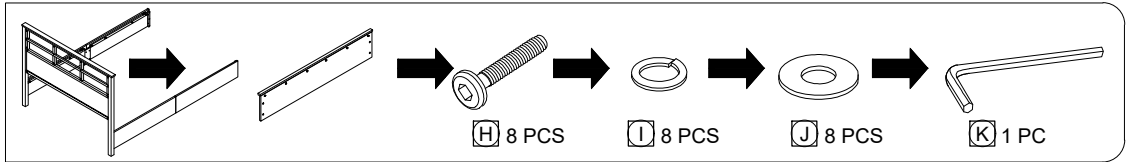

STEP 17

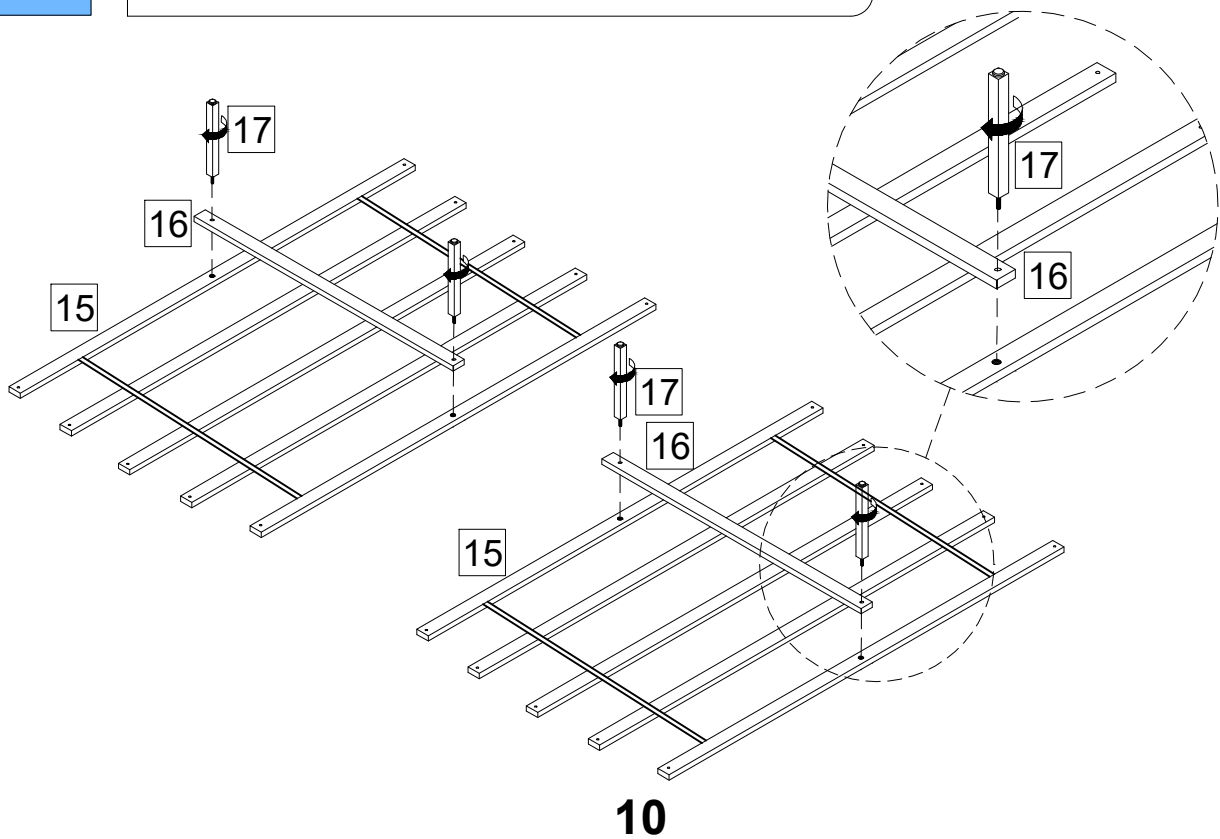
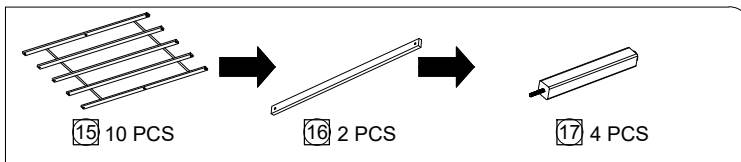

ASSEMBLY INSTRUCTION QUEEN/FULL BED

STEP
18



C 20 PCS

 **SCREWDRIVER
REQUIRED**

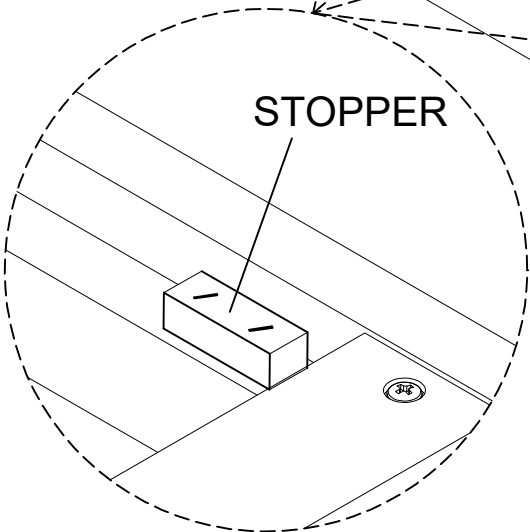
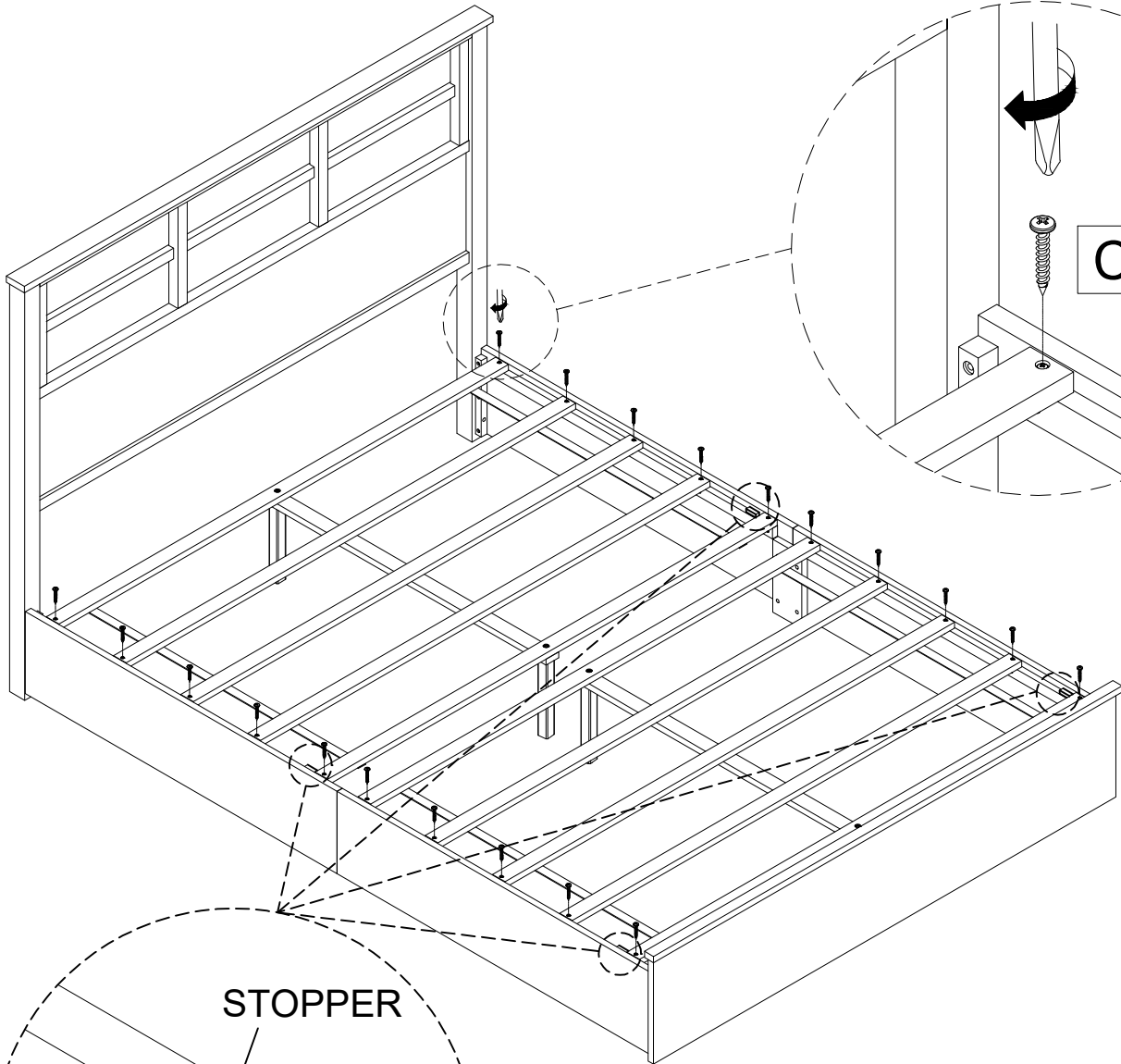

COMPLETED