

# ASSEMBLY INSTRUCTIONS



## CAUTION

◆ Inspect the wire insulation for any cuts, abrasions, or exposed copper that may have resulted during shipping. If there is a defect in the wire, do not attempt installation.

◆ Before starting installation of this fixture or removal of a previous fixture, disconnect the power by turning off the circuit breaker or by removing the fuse at the fuse box.

## TOOLS REQUIRED



Ladder



Safety glasses



Electrical tape



Phillips screwdriver



Flat blade screwdriver



Pliers

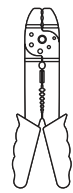

Wire strippers

## HARDWARE INCLUDED

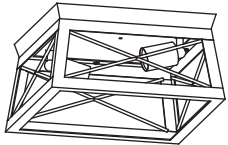

Fixture

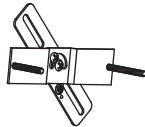

Mounting Unit



Rubber Rings



Mounting Screws



Wire Nuts

**\*PARTS SHOWN MAY DIFFER SLIGHTLY PER LIGHT FIXTURE**

## EXPLODED PARTS

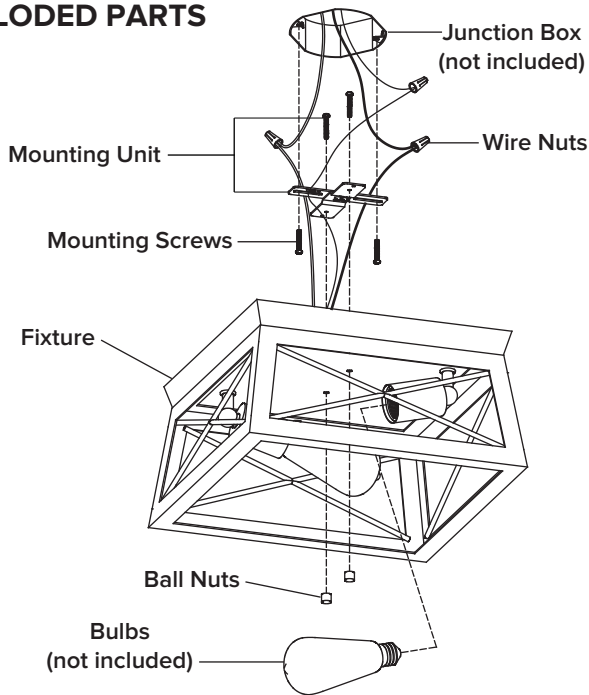

## INSTALLATION

### STEP 1

Unscrew the **ball nuts** from the **mounting unit**. Use the **mounting screws** to attach the **mounting unit** to the junction box (not included).

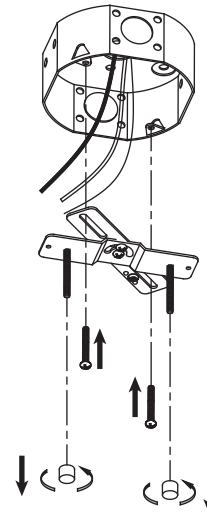

### STEP 2

Make the electrical connection from the junction box (not included) to the **fixture**. Connect the ground wire to the **mounting unit** using the preinstalled green ground screw. Then, connect the positive, negative and ground wires with the supplied **wire nuts**. Secure with electrical tape.

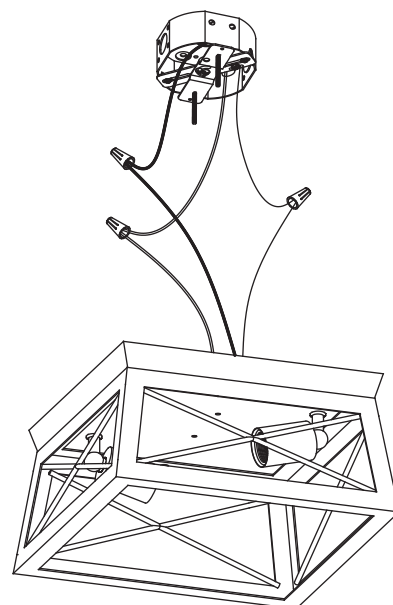
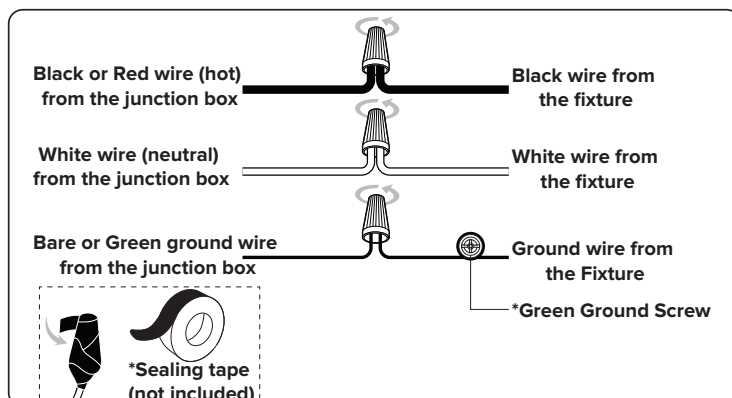

## ASSEMBLY INSTRUCTIONS (INSTALLATION)

---

### STEP 3

Attach the **fixture** to the **mounting unit** through screws holes as shown, and secure it with **ball nuts**.

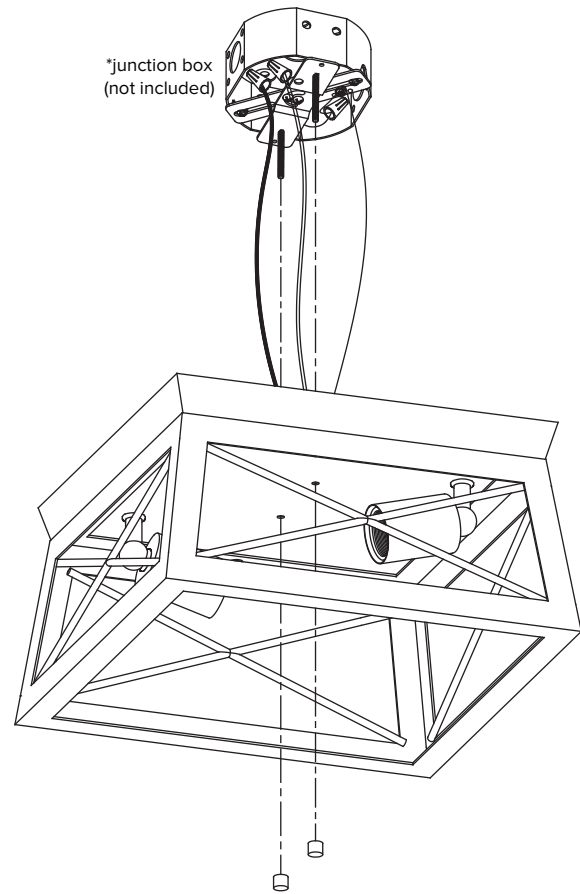

### STEP 4

Install bulbs (not included)

