

**WALKER EDISON**  
™

# 20" Atticus Solid Wood 1 Drawer Nightstand

SKU# BR1DATTNS

LOT: AYYWW-XXX

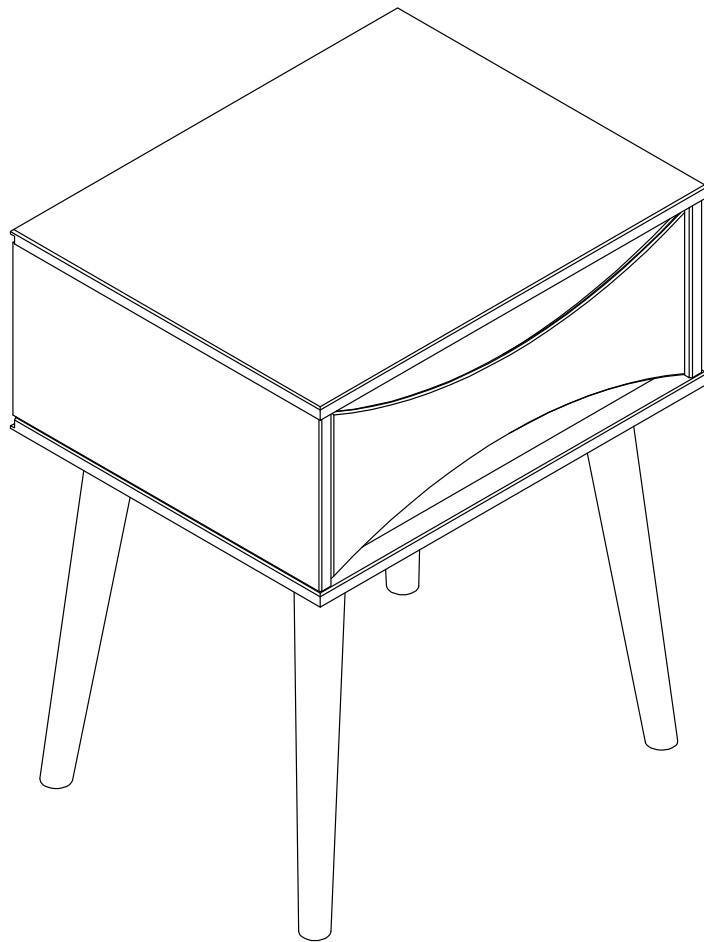

**For Residential Use Only**

Please visit our website for the most current instructions, assembly tips, report damage, or request parts. [www.walkerediton.com](http://www.walkerediton.com)

# WE Time to get started

Set up a clean and soft workplace to avoid damage during assembly. You can use the box and internal protections as a cover. It also helps to double-check if you have got all the pieces and parts before diving into the assembly.

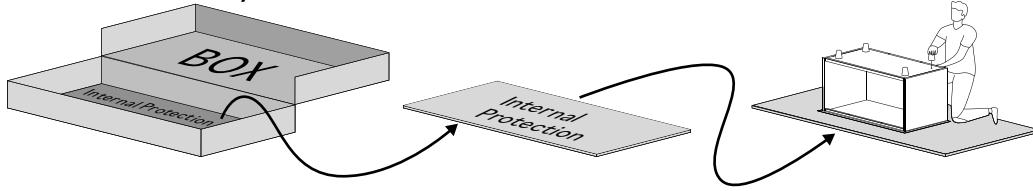

**Estimated time for assembly**

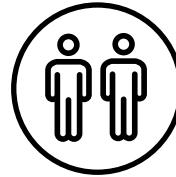

2 People Build

**People recommended for assembly**

Make it a team effort!  
Grab a friend for quicker, easier assembly.

## Tools Needed

Grab a Phillips head screwdriver and a hammer to conquer this assembly.

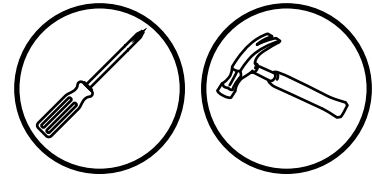

## Use power tools with caution

This furniture is made of Solid Wood and Composite Wood, soft materials. If you choose to use power tools, set it to the slower setting. Be careful! Power tools can cause cracking or damage to the furniture, it can also break the hardware if misused. Power tool damages are not covered by the Walker Edison warranty.

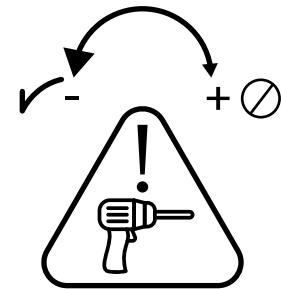

## Slide care

Your furniture has highly durable wooden sliders. From time to time we recommend applying paraffin or standard candle wax to improve gliding of the sliders.

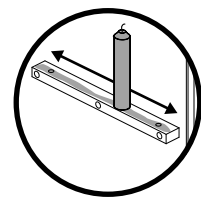

**Scan to get assembly tips and help!**









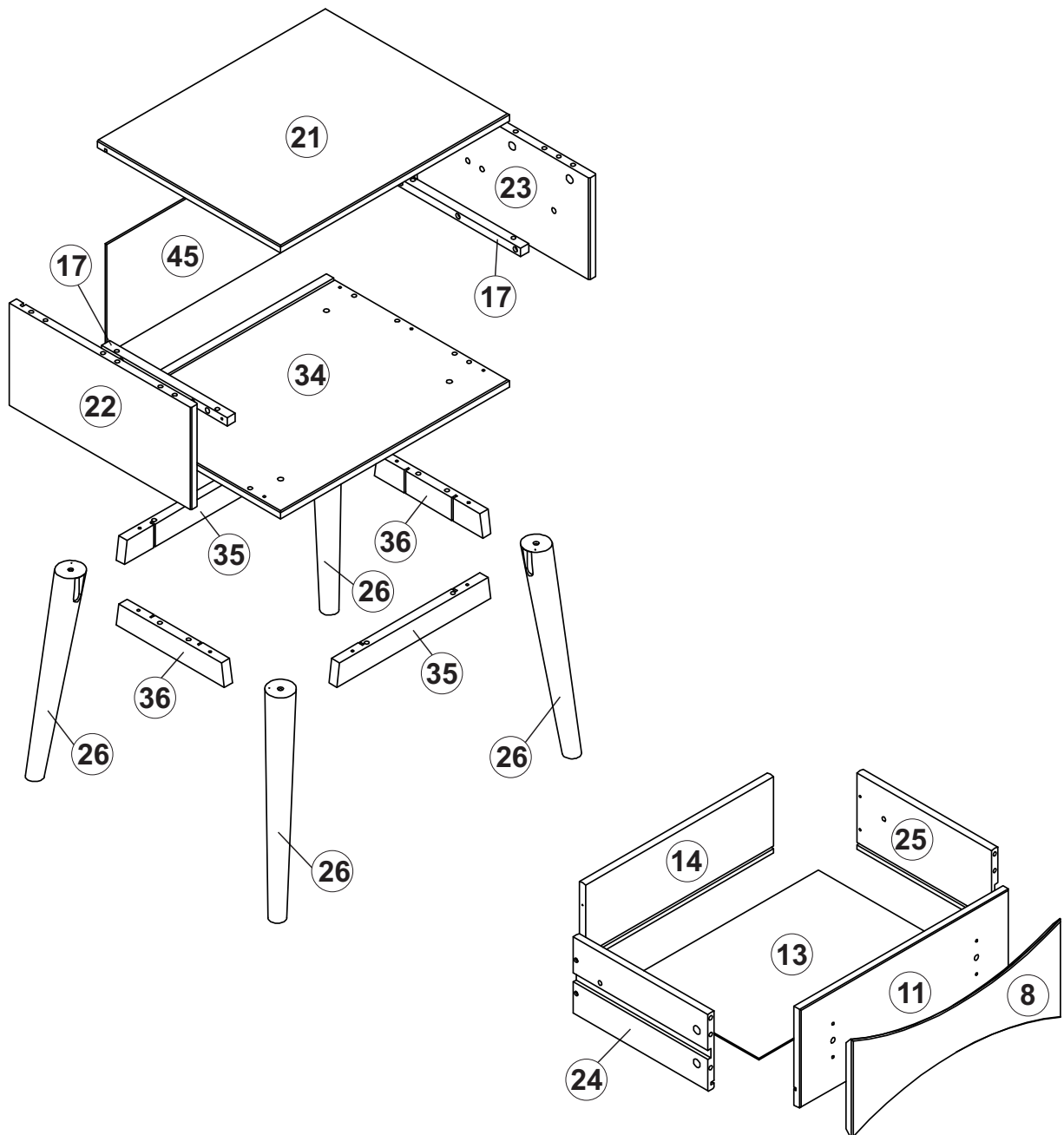



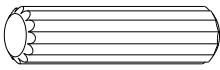
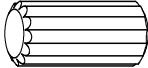

# Parts List

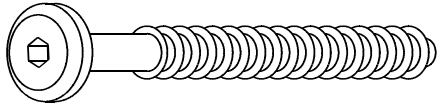
Part Number	Description	Quantity
8	Drawer Handle	1
11	Drawer Front	1
13	Drawer Bottom	1
14	Drawer Back	1
17	Wood Slider	2
21	Top Panel	1
22	Left Side Panel	1
23	Right Side Panel	1

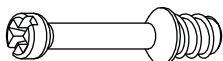
Part Number	Description	Quantity
24	Left Drawer Side	1
25	Right Drawer Side	1
26	Foot	4
34	Base	1
35	Front Foot Rail	2
36	Side Foot Rail	2
45	Back Panel	1

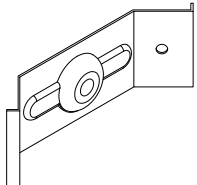

# WE Hardware List

Part	Size	Name	Quantity
A	 Ø8*30mm	Wooden dowel	26
B	 Ø10*20mm	Wooden dowel	08
C	 Ø4,0*25mm	Screw	10
D	 Ø3,5*30mm	Screw	04
E	 Ø4,0*40mm	Screw	15
G	 Ø7,0*50mm	Screw	08
H	 4mm	Hex Key	01
I	 Ø8*40mm	Wooden dowel	02
J	 ø15*30mm	Cam bolt	10
K	 ø15*10mm	Cam lock	10
L		Wall anchor	01
M		Washer	02
N	 Ø6*35mm		01
O	 Ø4*16mm	Screw	09
P		Angle bracket	04

*The hardware quantities listed above are required for proper assembly.*

*Extra hardware pieces may be included.*

# Step 1

Let's get started. Start by inserting wooden dowel (B) into the Drawer Handle (8) and Wood Slider (17).

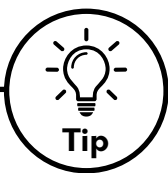
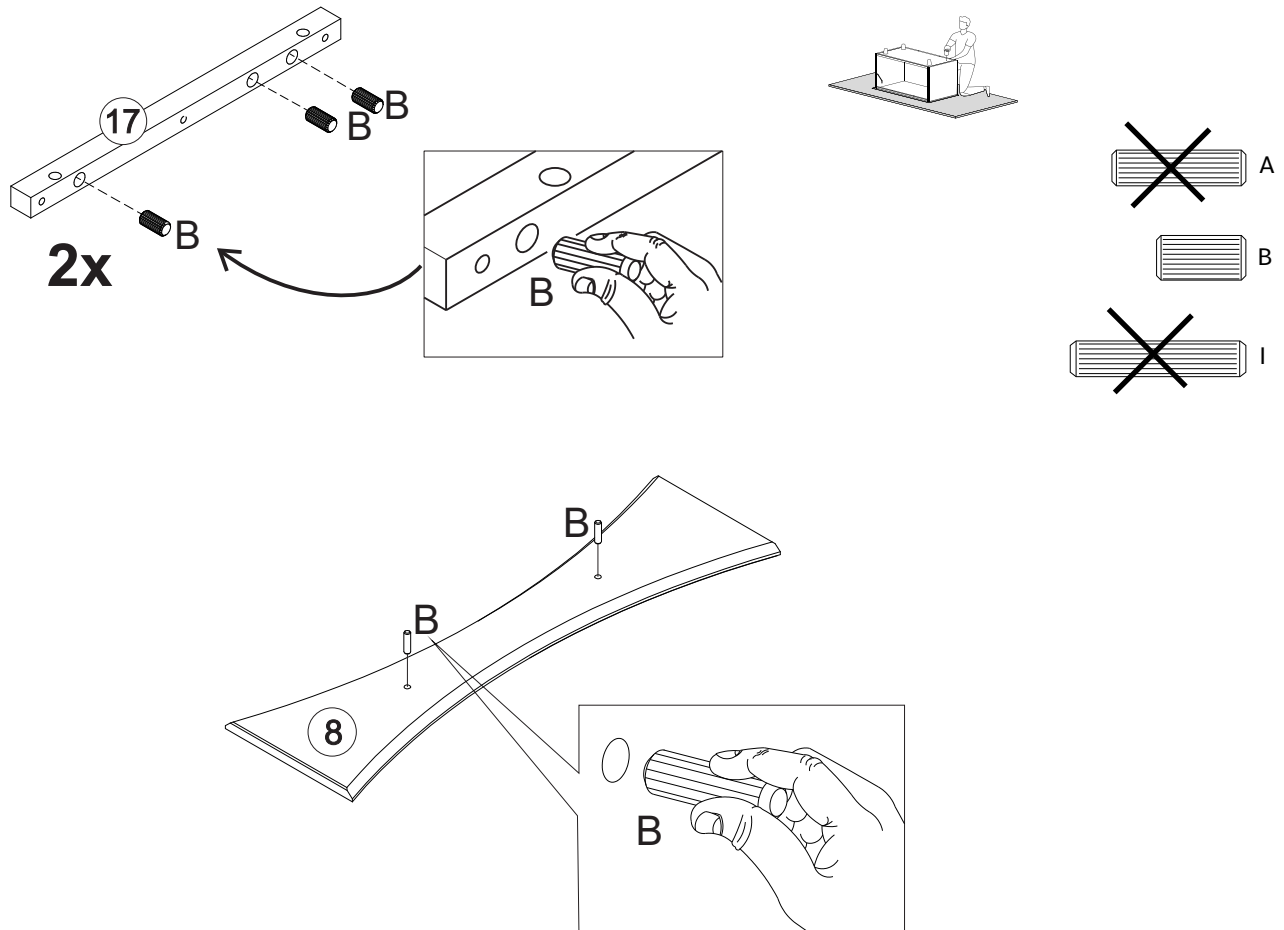

Tip

## Wood Dowels

Dowels are essential in furniture assembly to create strong, precise connections.

They ensure structural integrity, prevent shifting, and simplify alignment, resulting in sturdier, longer-lasting furniture.

Follow these steps:

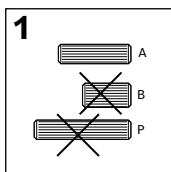

1: Select the appropriate size dowel according with step.

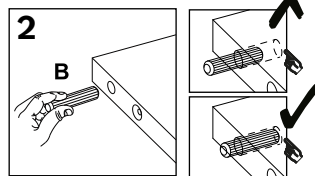

2: Insert into drilled hole and press firmly to ensure placement is set.

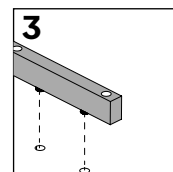

3: Align the dowel with corresponding piece and press together until secure.

# Step 2

Insert wooden dowel (A) into the Left Side Panel (22), Right Side Panel (23), Left Drawer Side (24), Right Drawer Side (25), Front Foot Rail (35) and Side Foot Rail (36) .

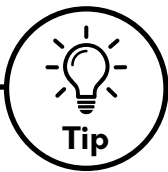
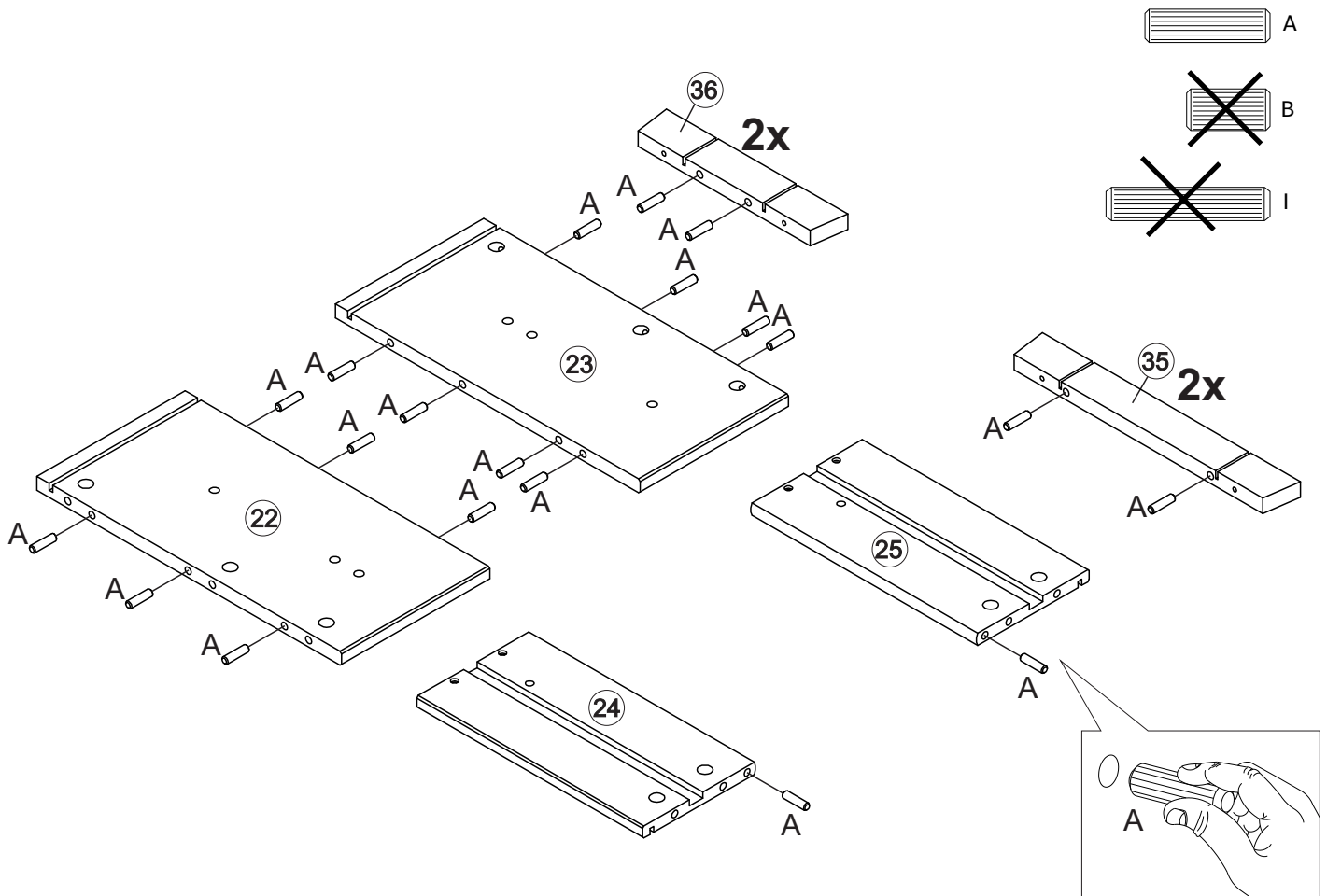

**Tip**

To keep your product looking its best and scratch-free, try assembling it on a soft surface like carpet or a blanket. This helps prevent any accidental scratches and keeps your furniture in top shape!

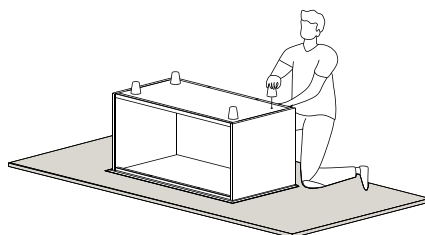

# Step 3

Fix the Cam Bolt (J) into the Drawer Front (11) and Top Panel (21) using a Phillips Head Screwdriver.

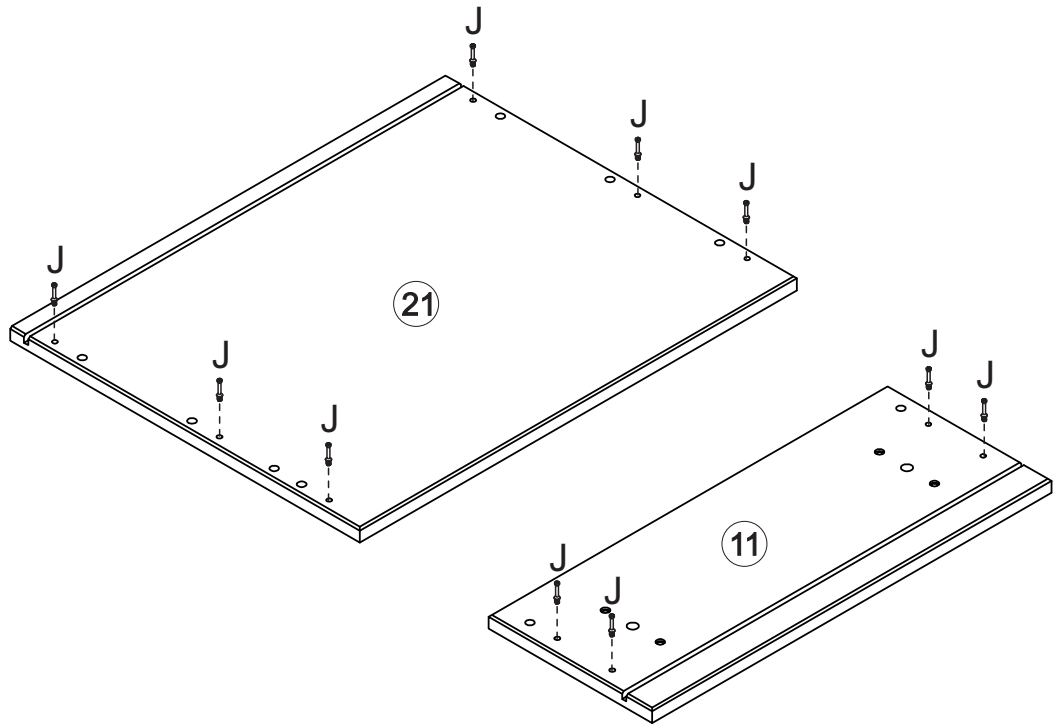
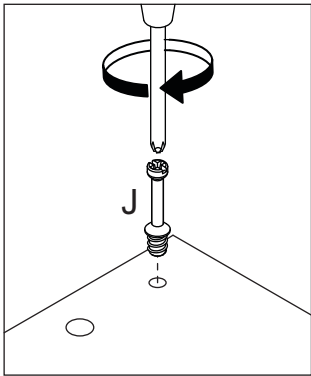

# Step 4

Secure Wood Slider (17) to Left Side Panel (22) and Right Side Panel (23) with Screws (C) using a Phillips Head Screwdriver.

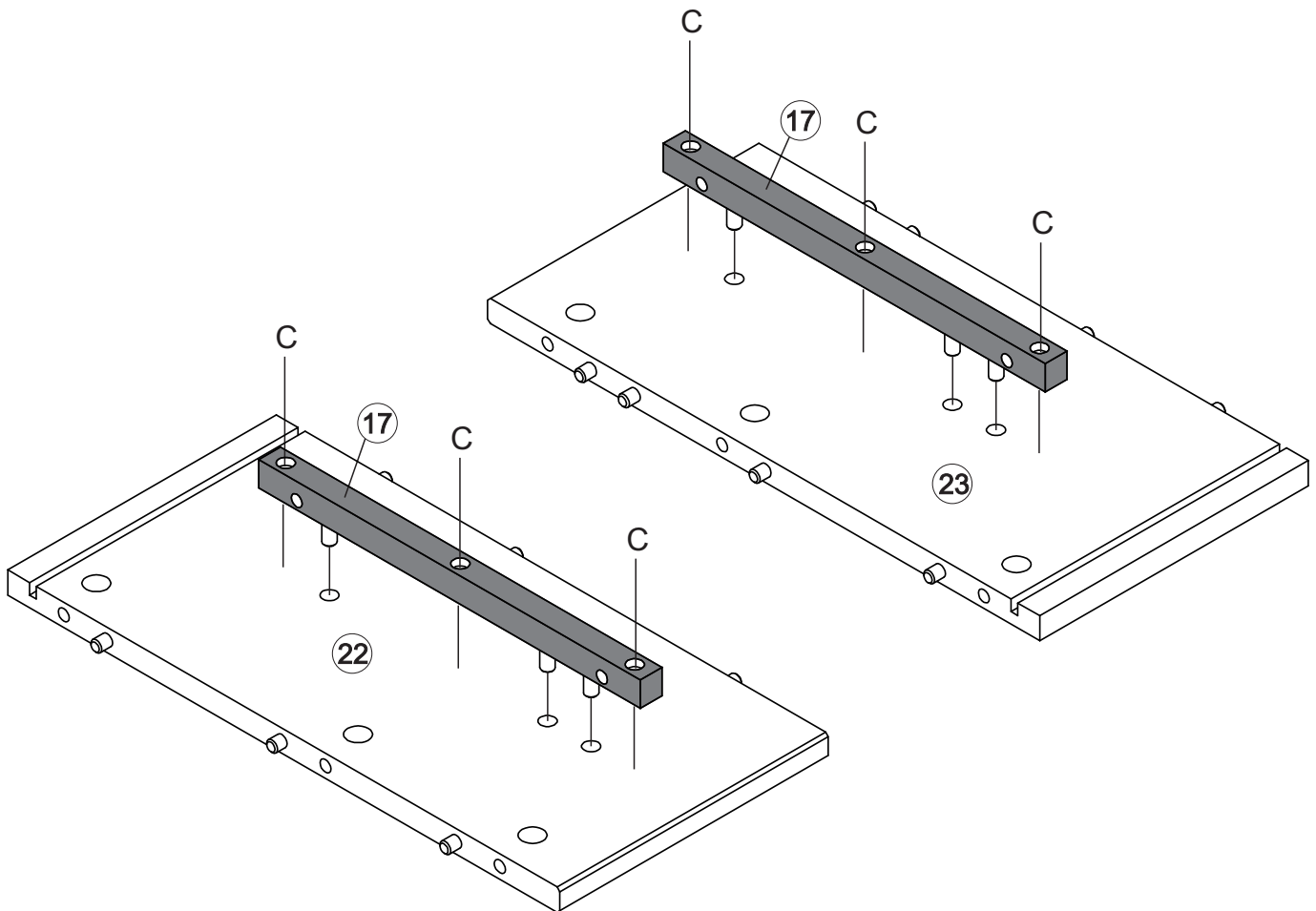
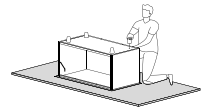

# Step 5

Secure Top Panel (21) to Left Side Panel (22) and Right Side Panel (23) with Cam Locks (K) using a Phillips Head Screwdriver.

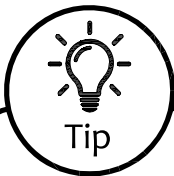
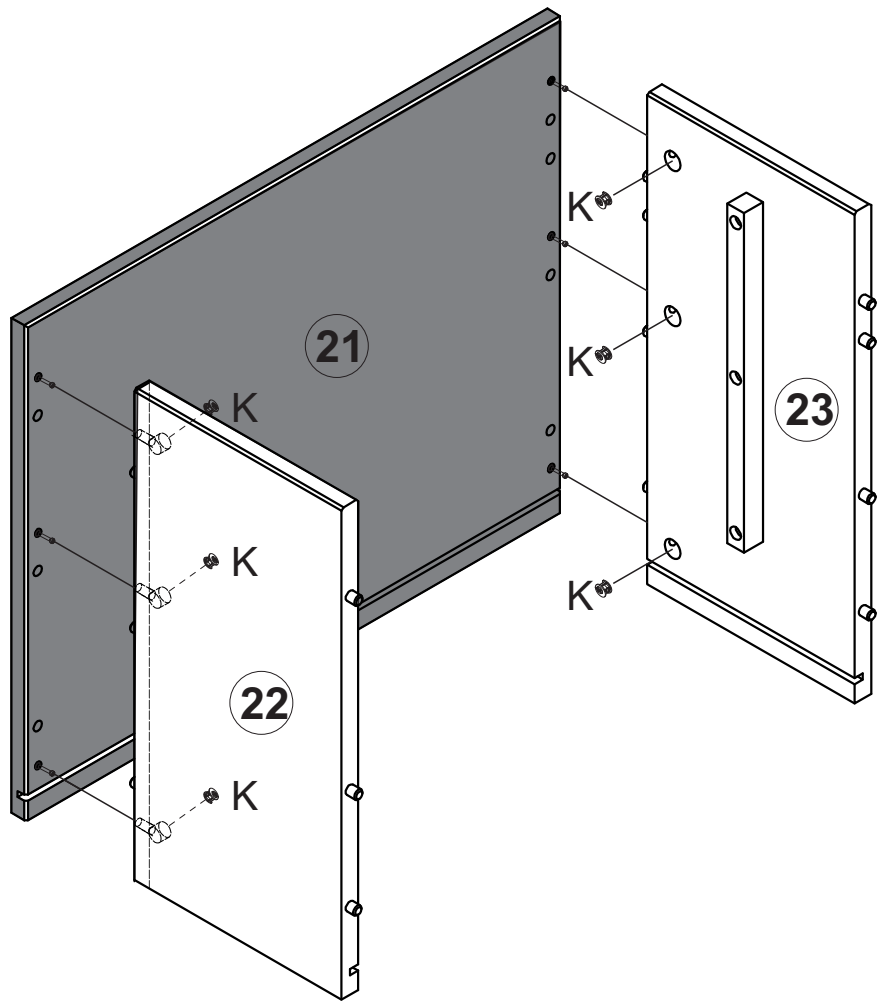
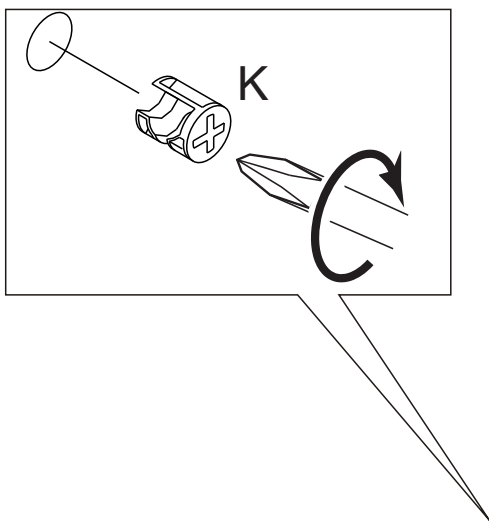

Tip

## Cam Locks

Cam Locks help securely join two pieces together.  
Follow these easy steps.

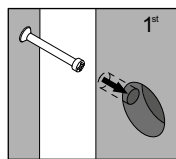

1: Insert Cam Bolt into bolt holes on the flat side. Don't over tighten!

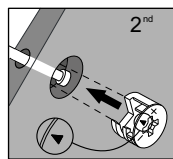

2: Assemble both parts together. The cam bolt goes in the drilled holes that have a circular hole on the side, you should be able to see the cam bolt through it. After fitting parts together insert the cam lock on the side holes.

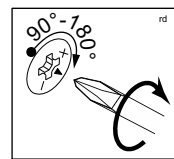

3: On the back of the Cam Lock will be a "C" shape. Insert the Cam Lock so the opening of the "C" fits over the Cam Bolt. Tighten with the screwdriver.

# Step 6

Attach Front Foot Rail (35) to Base (34) with Screws (E) using a Phillips Head Screwdriver.

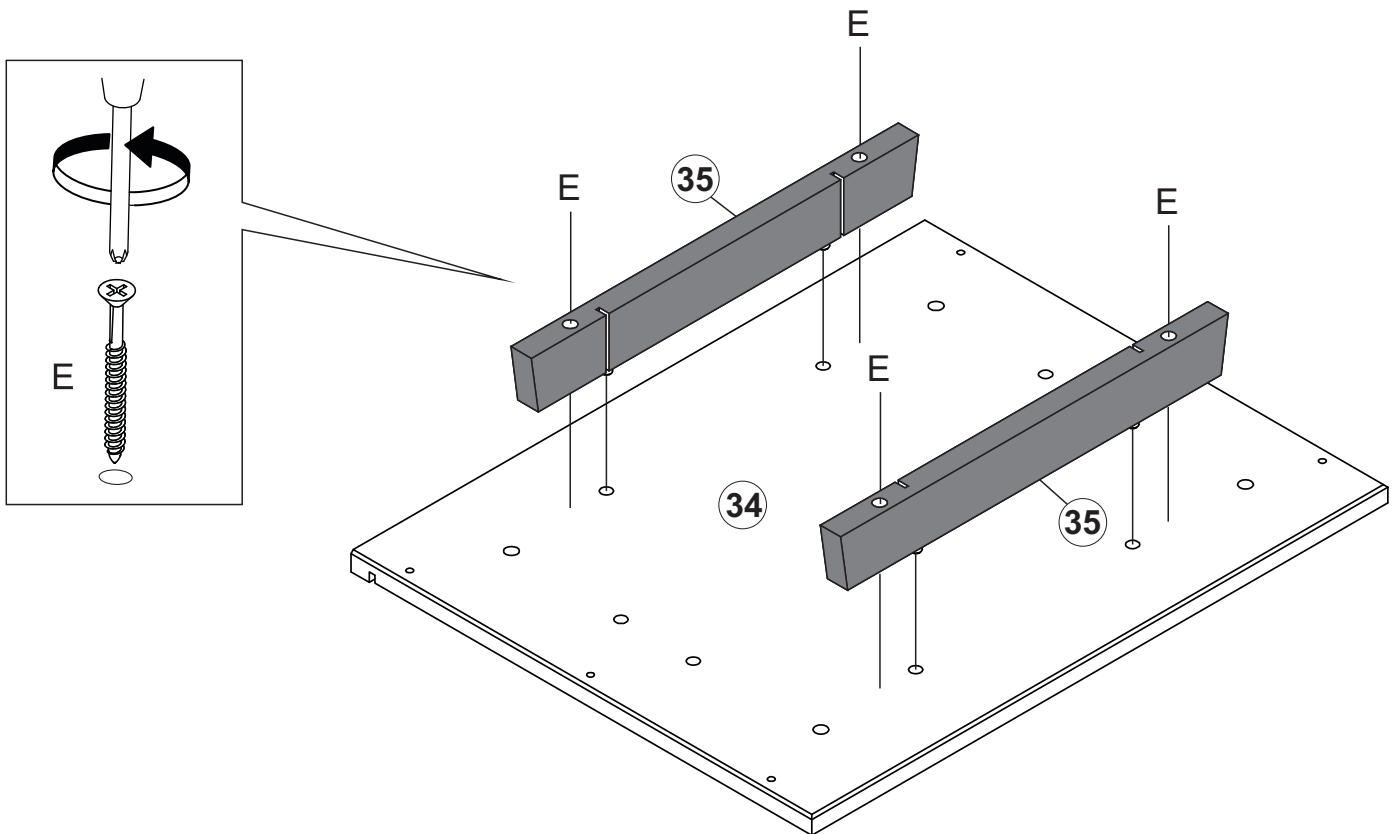

# Step 7

Insert Foot (26) to Side Foot Rail (36) and insert on Base (34).

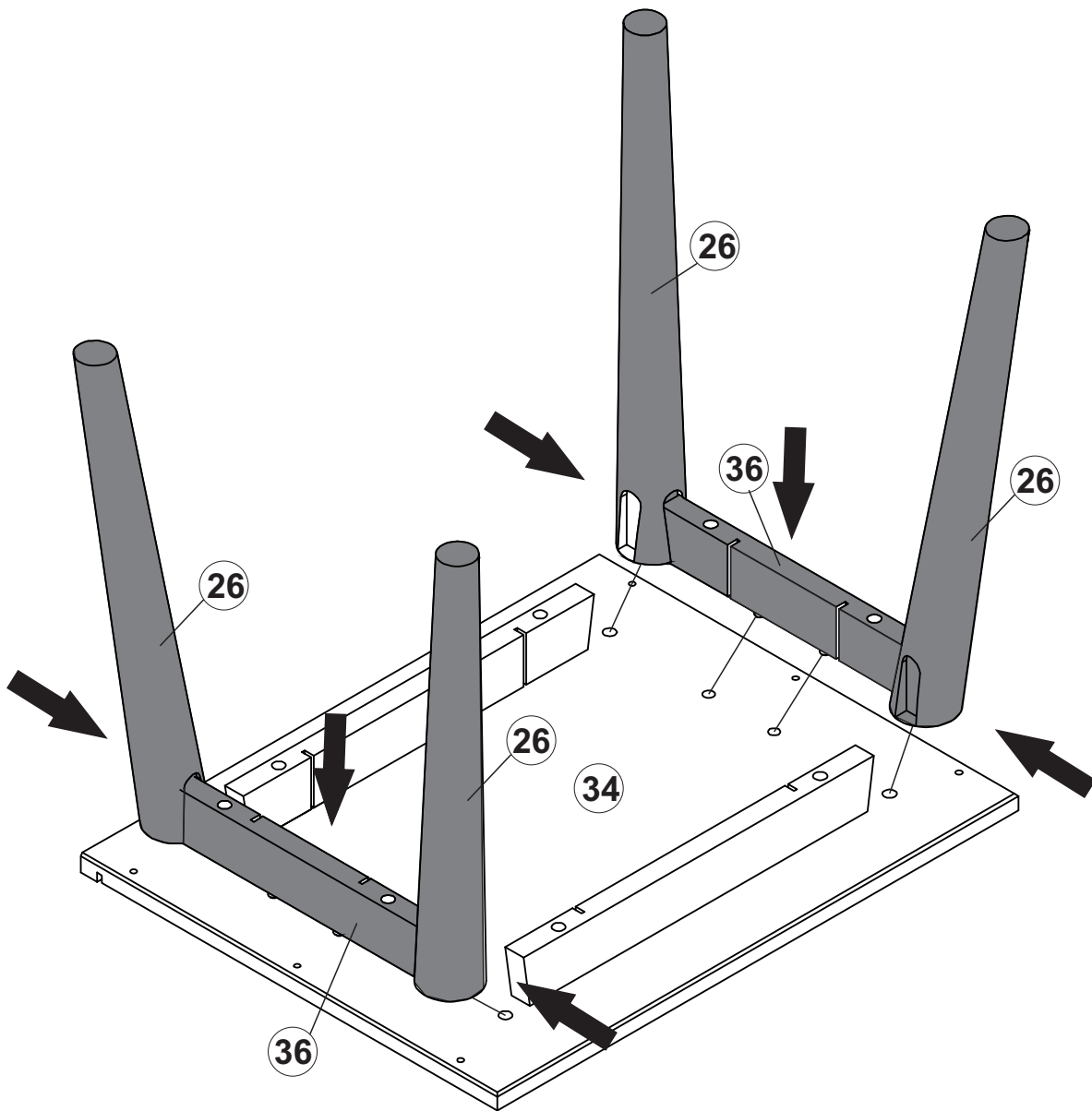
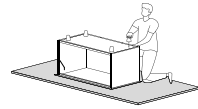

# Step 8

Attach Side Foot Rail (36) to Base (34) with Screws (E) using a Phillips Head Screwdriver.

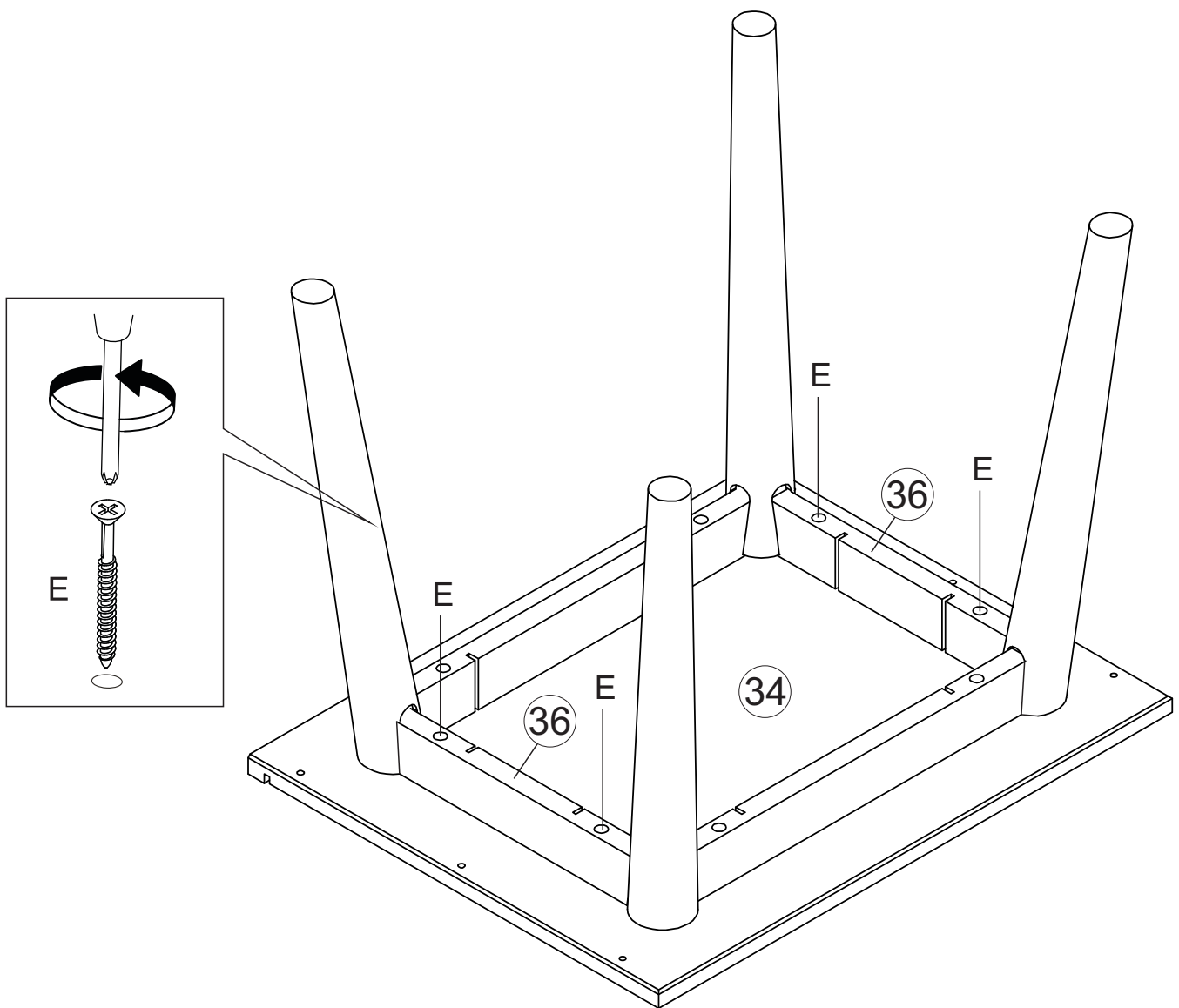

# Step 9

Attach Angle Bracket (P) to Base.

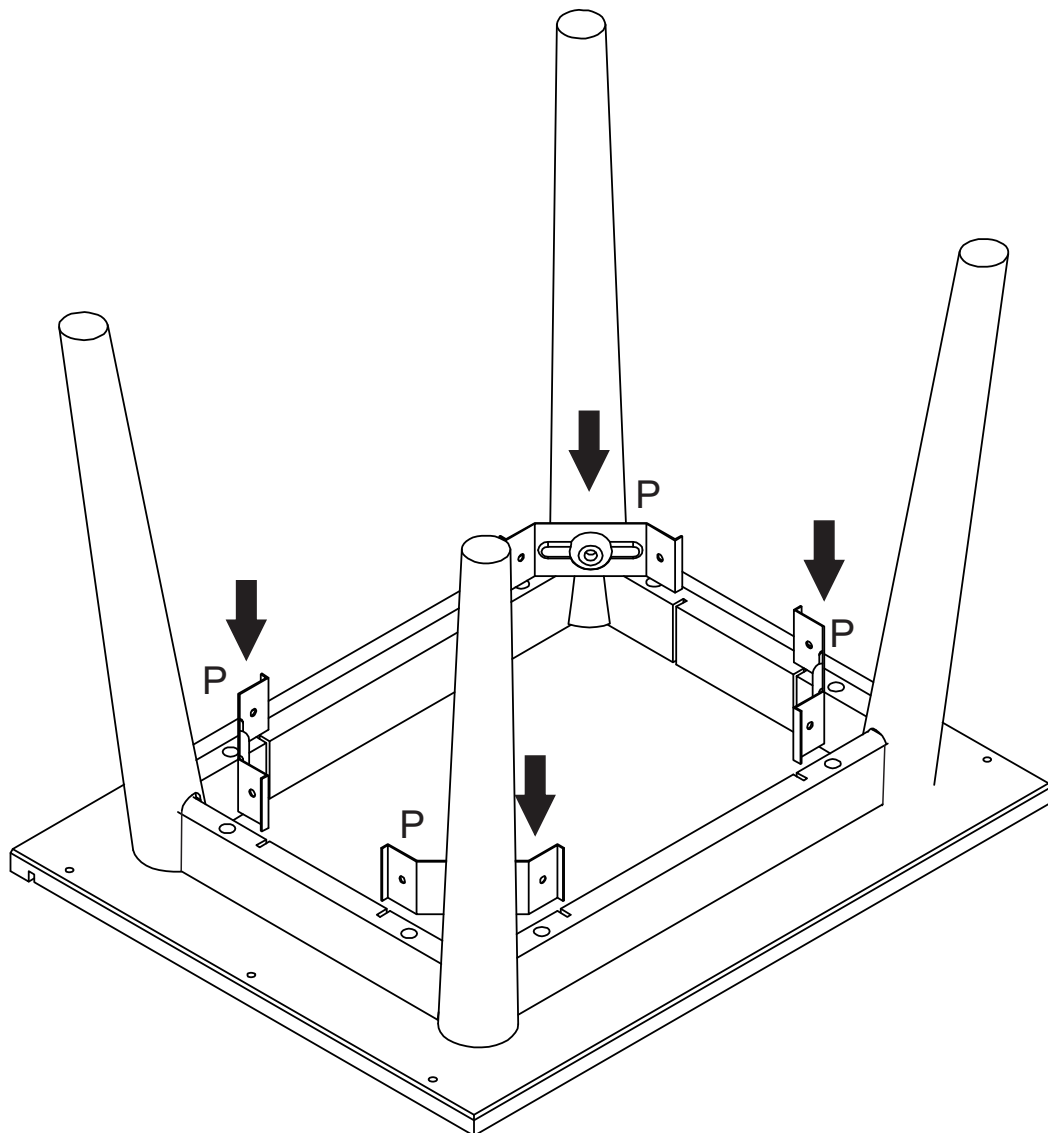
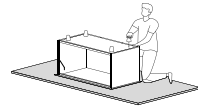

# Step 10

Attach Angle Brackets (P) to the assembled base with Screws (O) using a Phillips Head Screwdriver.

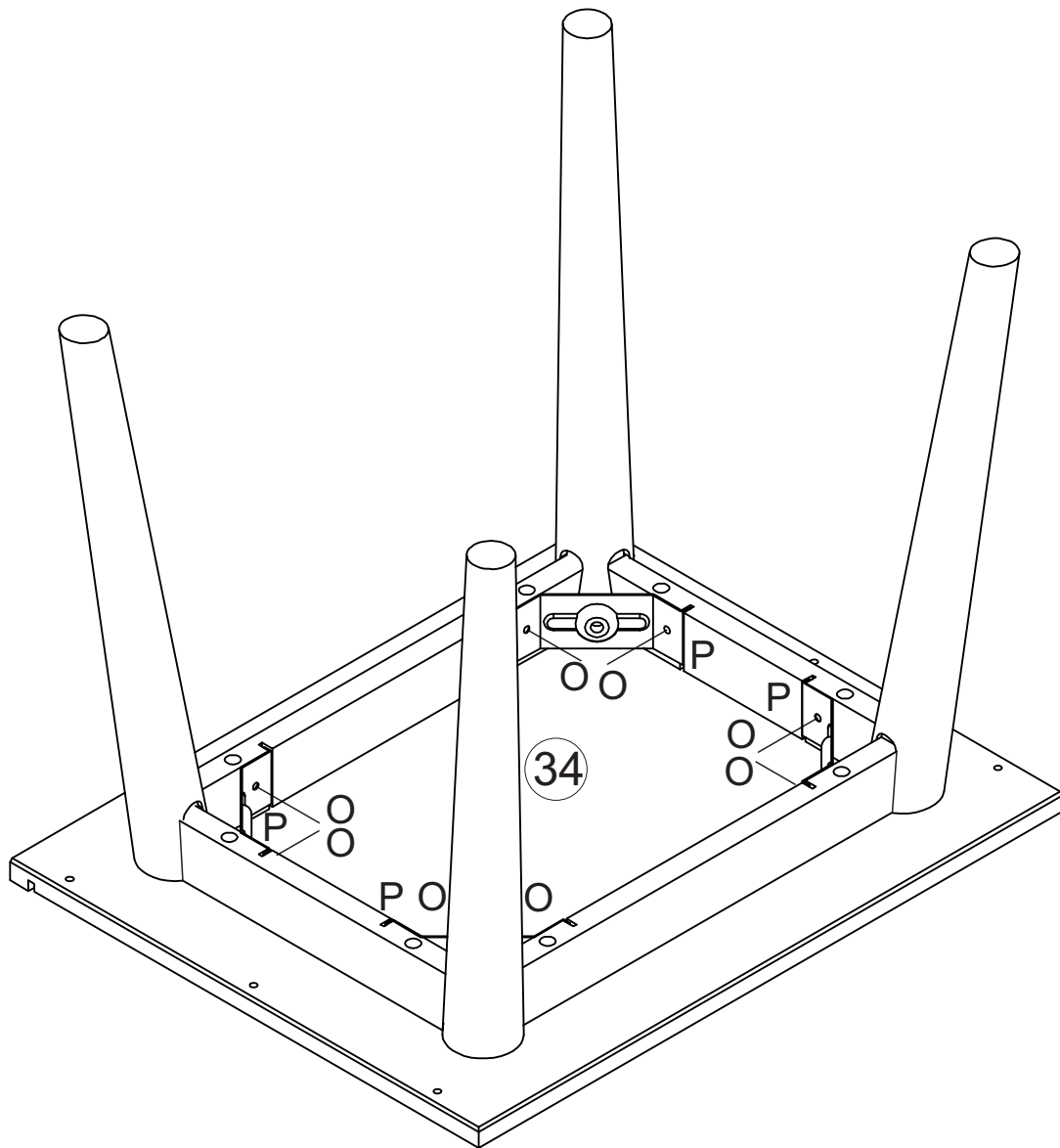
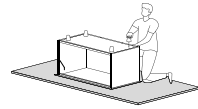

# Step 11

Insert Screws (G) into Angle Bracket (P) using a Hex Key (H).

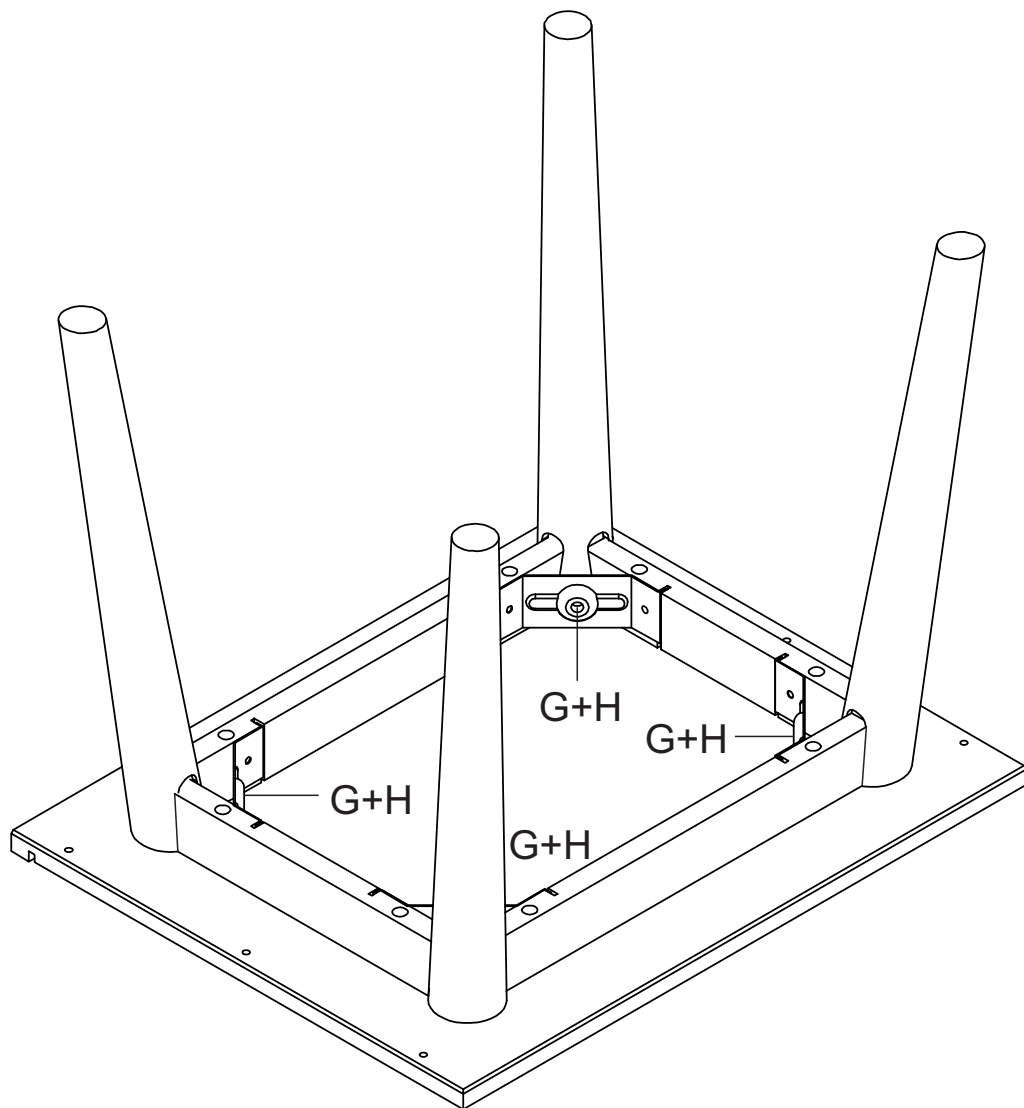
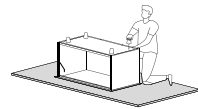

# Step 12

Attach Foot (26) to Base (34) with Screws (G) using a Hex Key (H).

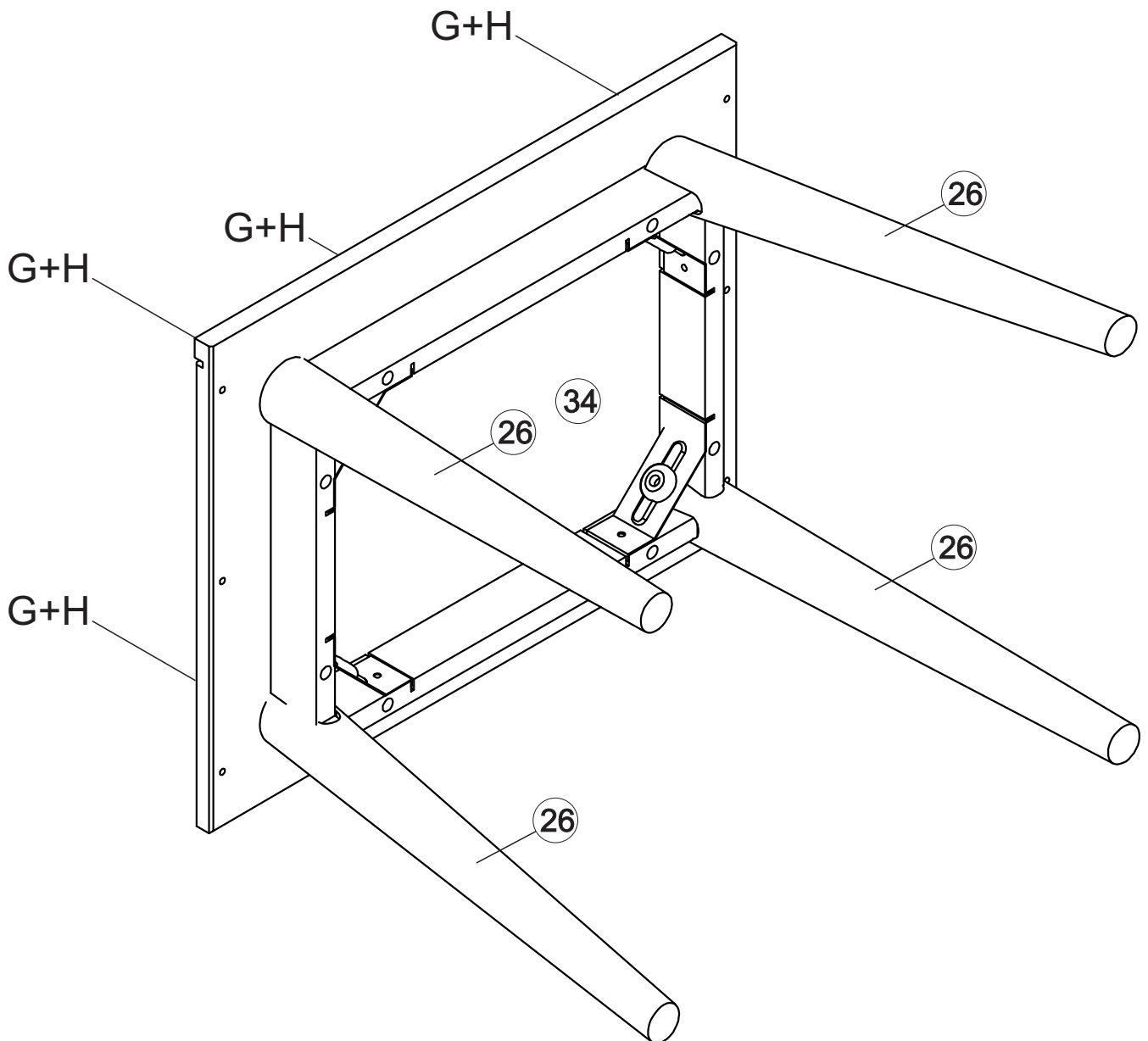

# Step 13

Insert Back Panel (45) between Left Side Panel (22) and Right Side Panel (23). Attach Base (34) to Left Side Panel (22) and Right Side Panel (23) with Screws (E) using a Phillips Head Screwdriver.

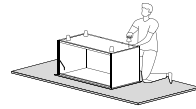

Name and address of the supplier and date of production.

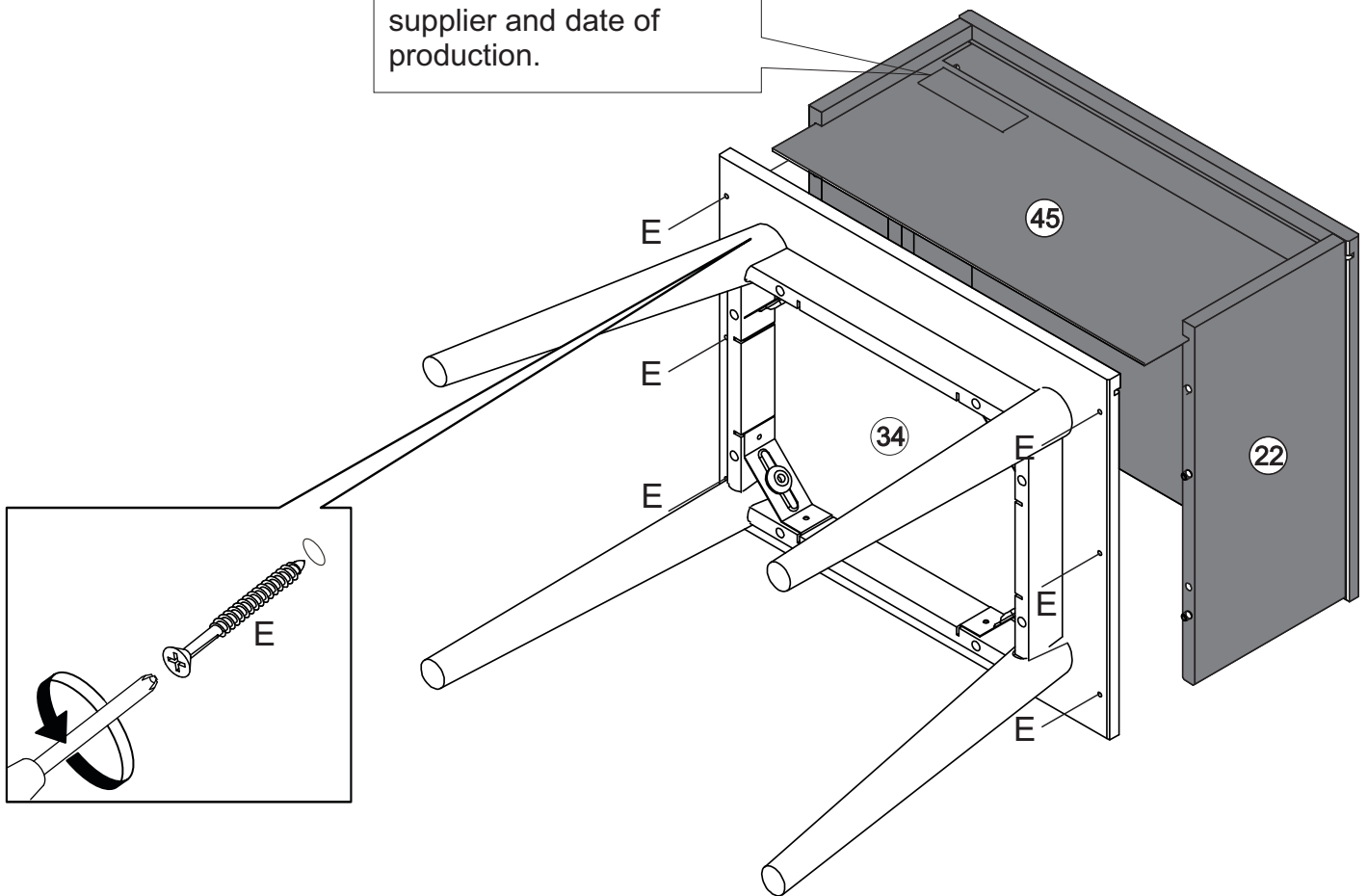

# Step 14

Attach Drawer Handle (8) to Drawer Front (11) with Screws (C) using a Phillips Head Screwdriver.

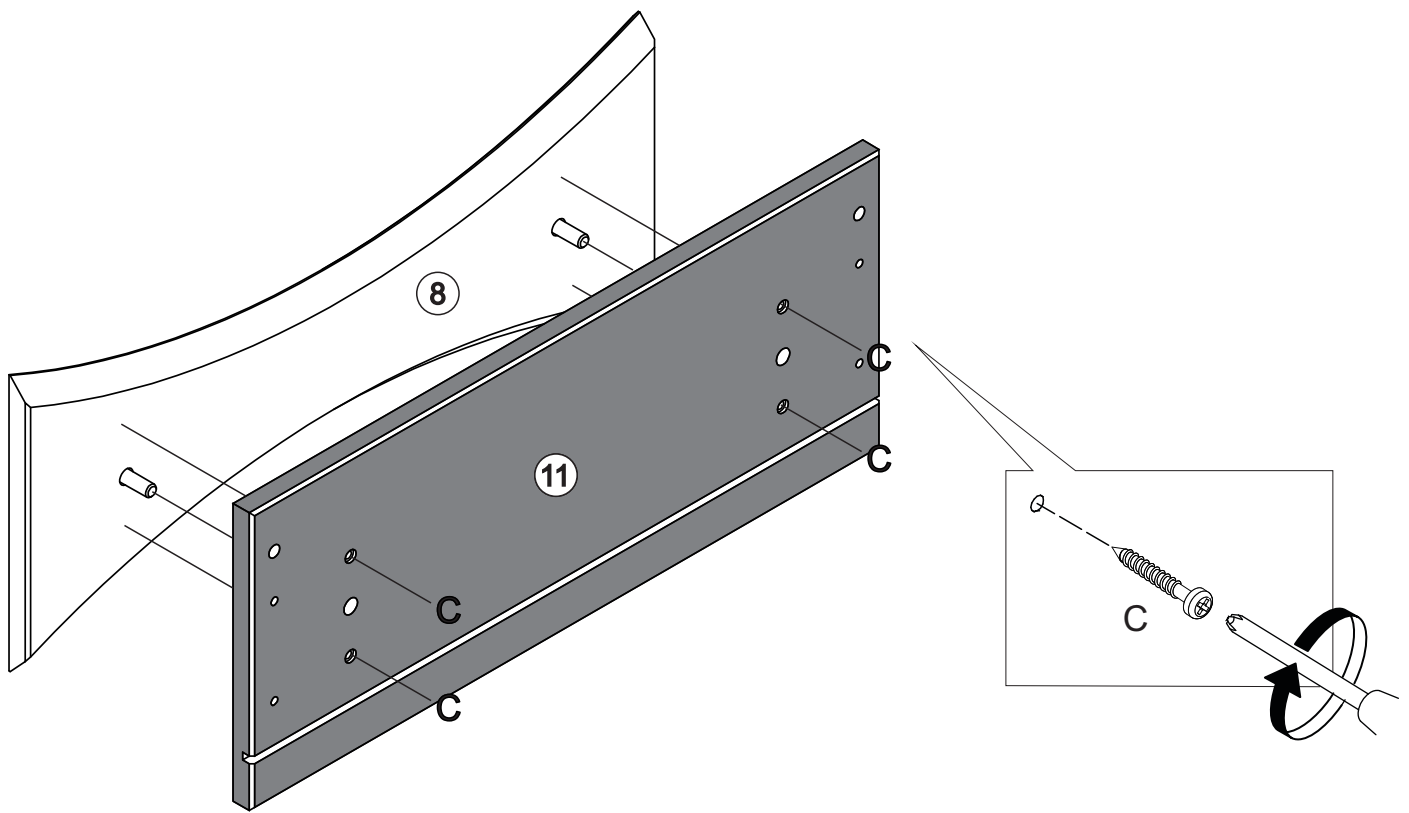

# Step 15

Attach Left Drawer Side (24) and Right Drawer Side (25) to Drawer Front (11) with Cam Locks (K) using a Phillips Head Screwdriver.

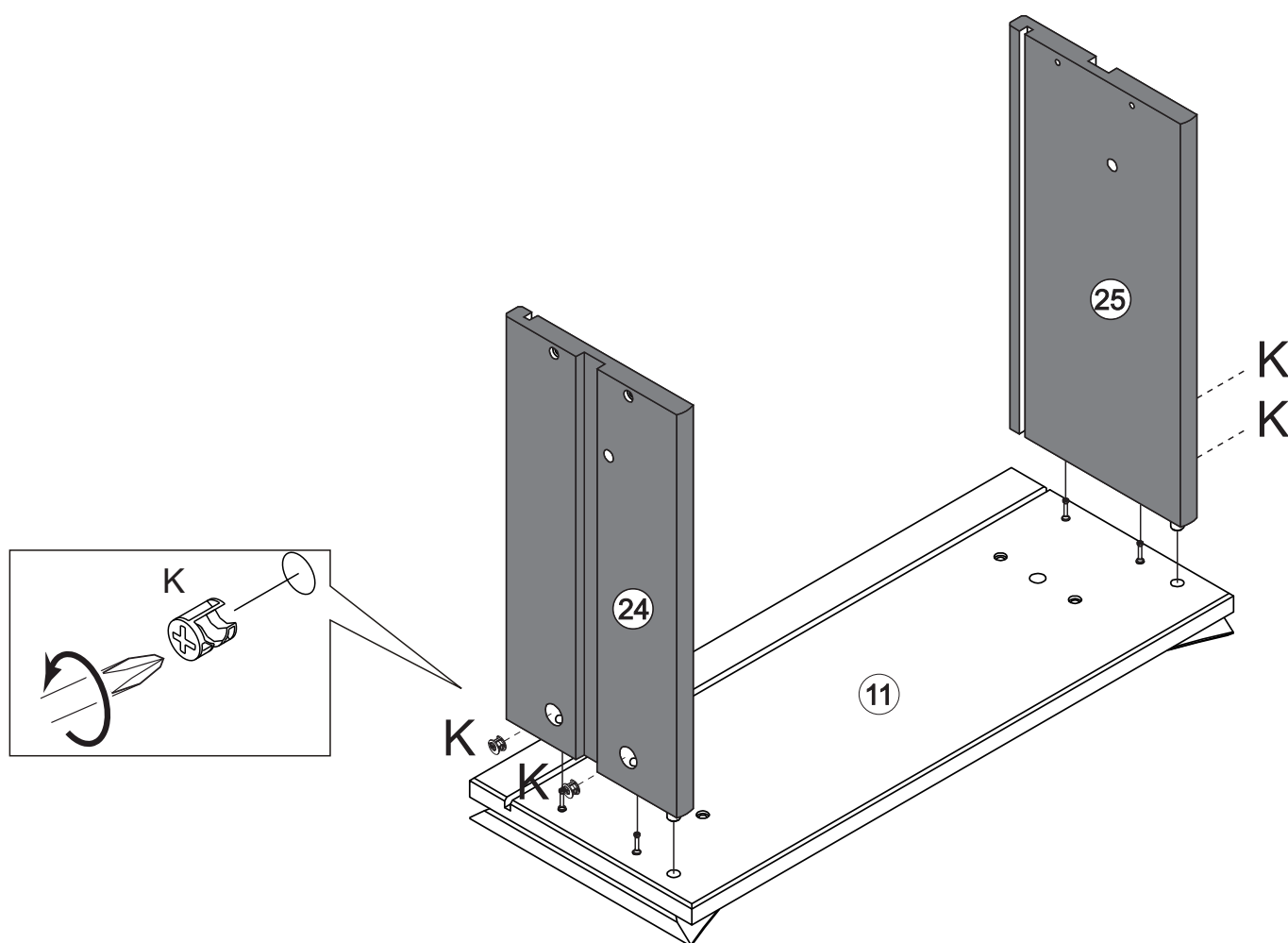
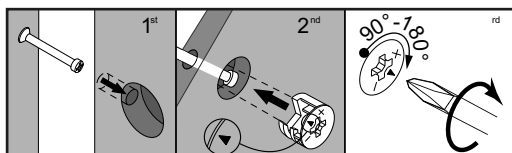

## Step 16

Insert Drawer Bottom (13) between the grooves of Left Drawer Side (24), and Right Drawer Side (25).  
Secure Drawer Back (14) to Left Drawer Side (24) and Right Drawer Side (25) with Screws (D) using a Phillips Head Screwdriver.

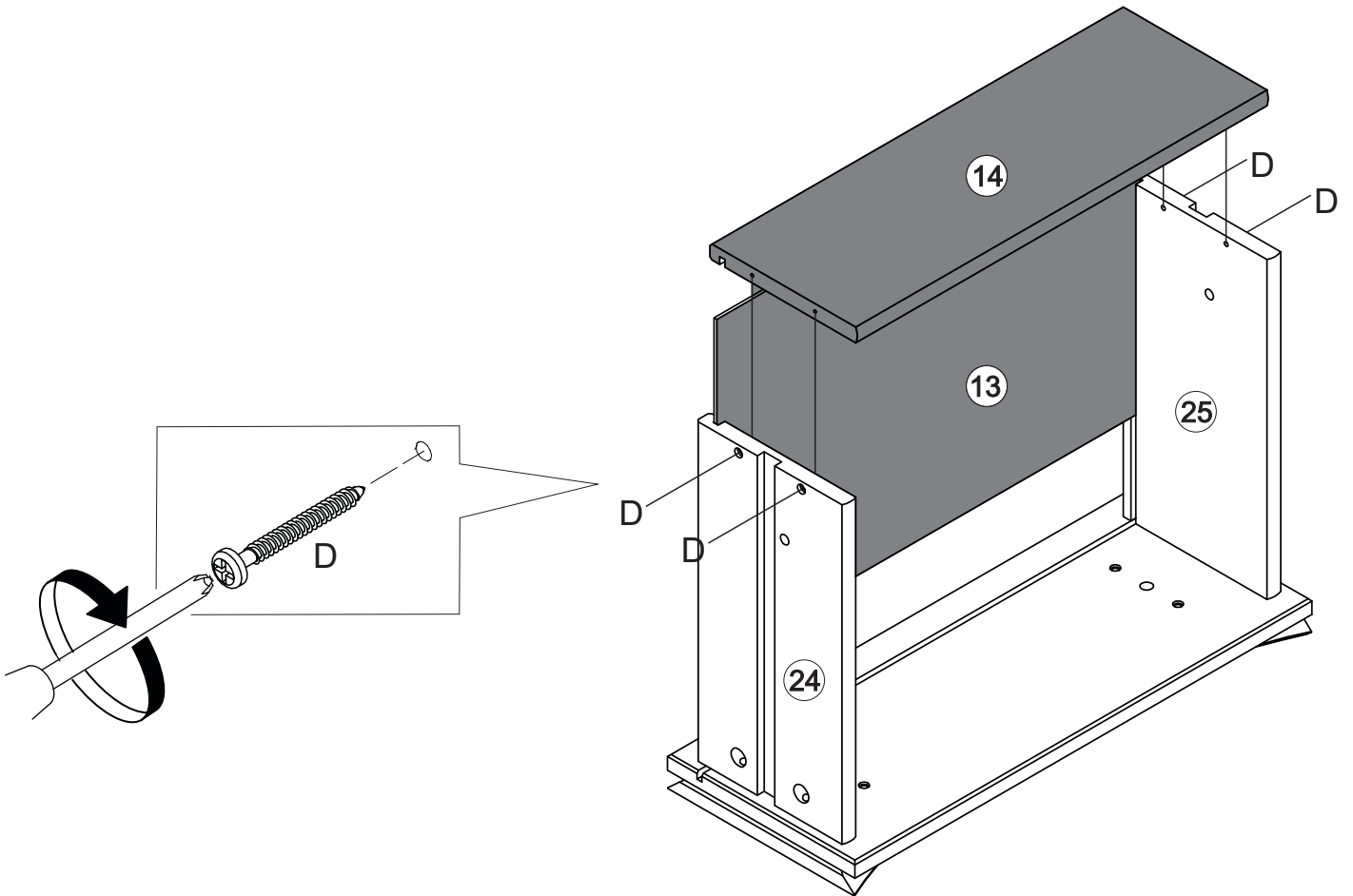

# Step 17

Insert Wodden Dowel (A) into Wood Slider (17) to be the stop of the drawer.

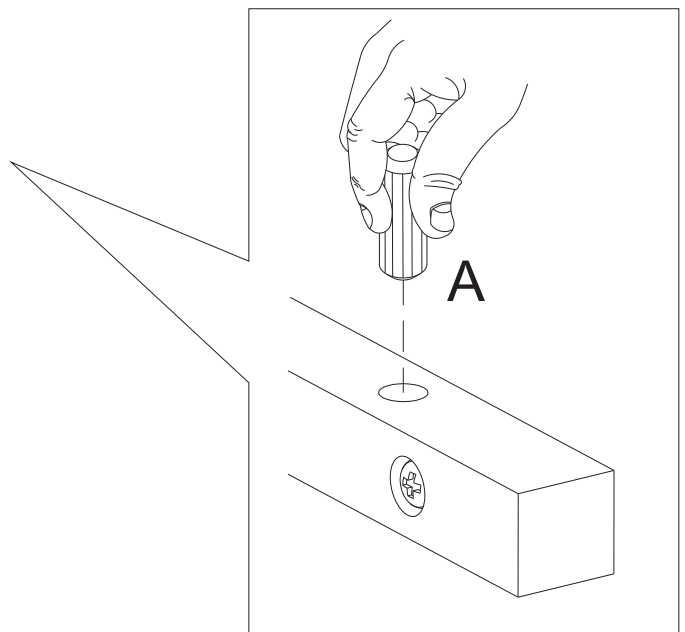
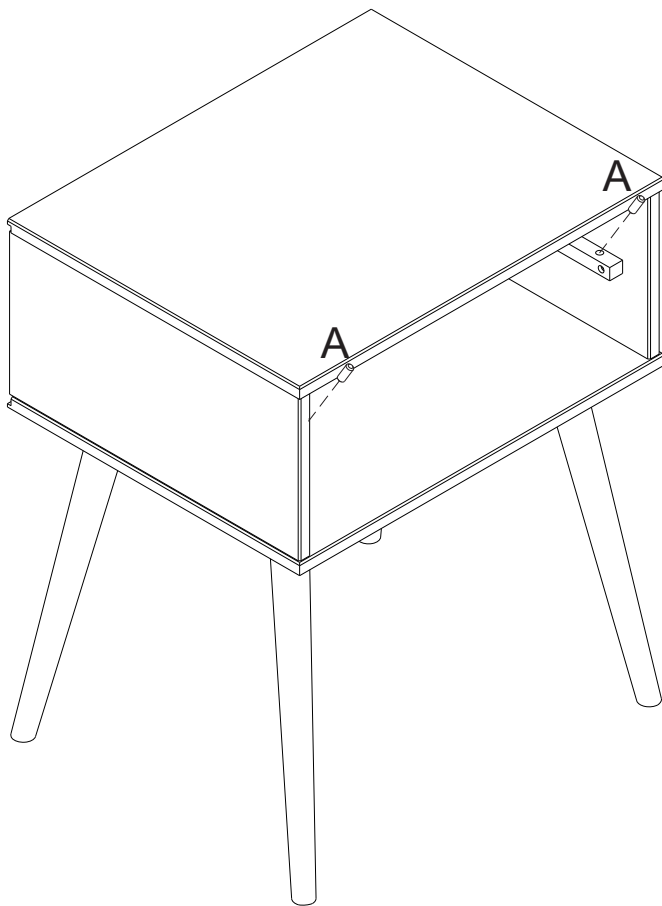

# Step 18

Insert Wodden Dowel (I) on the inside of all drawers, with the drawer inside the unit after having passed the wooden dowel that is in the Drawer Slider.

The dowel in not flush with the panel, it is a little inside the drawer to help when you need to remove the lock dowel to remove the drawer.

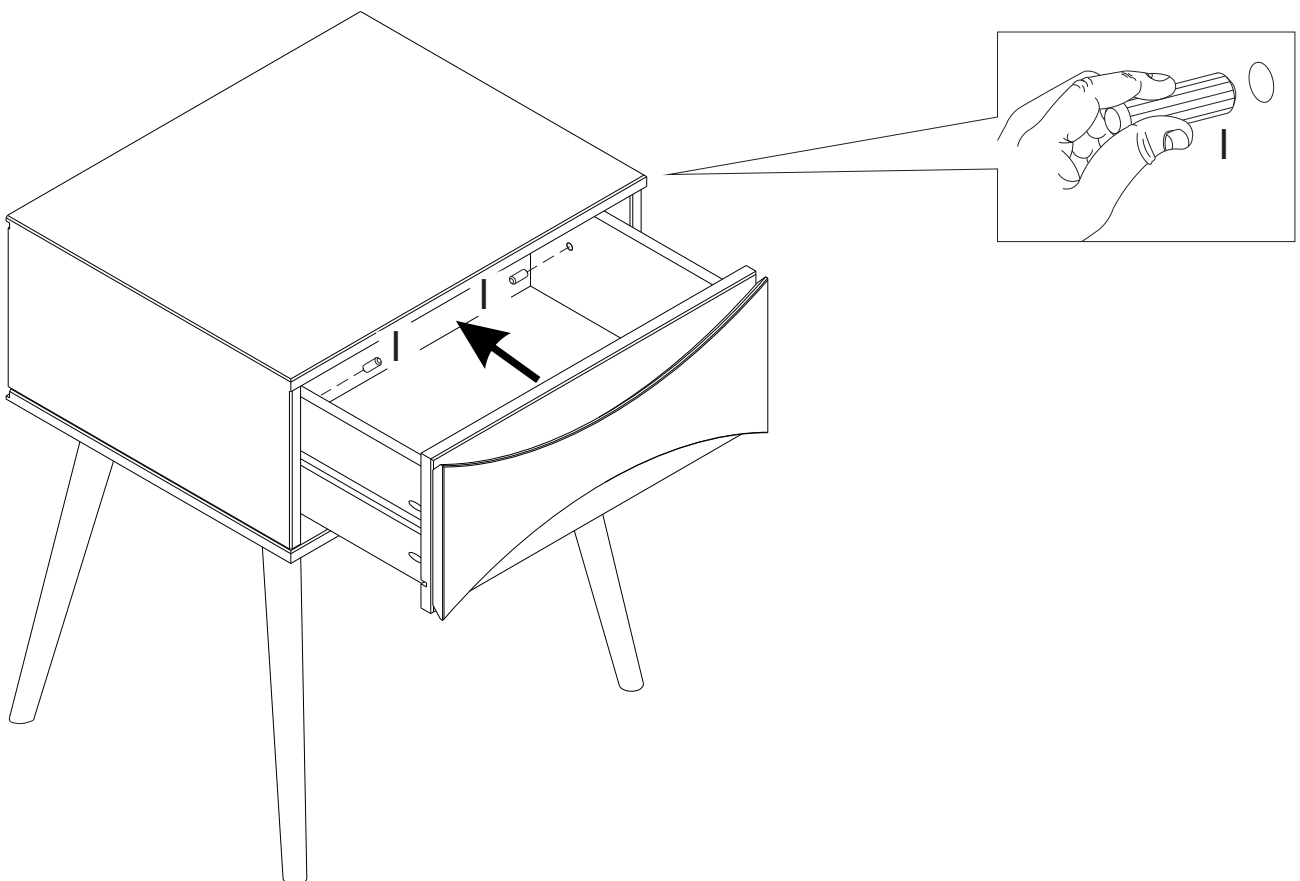
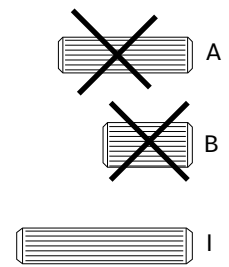

## Step 19

To finish this up, let's secure your Nightstand to the wall!  
Attach the Wall Anchor (L) to your dresser with a Washer (M)  
and a Screw (O) using a Phillips Head Screwdriver.

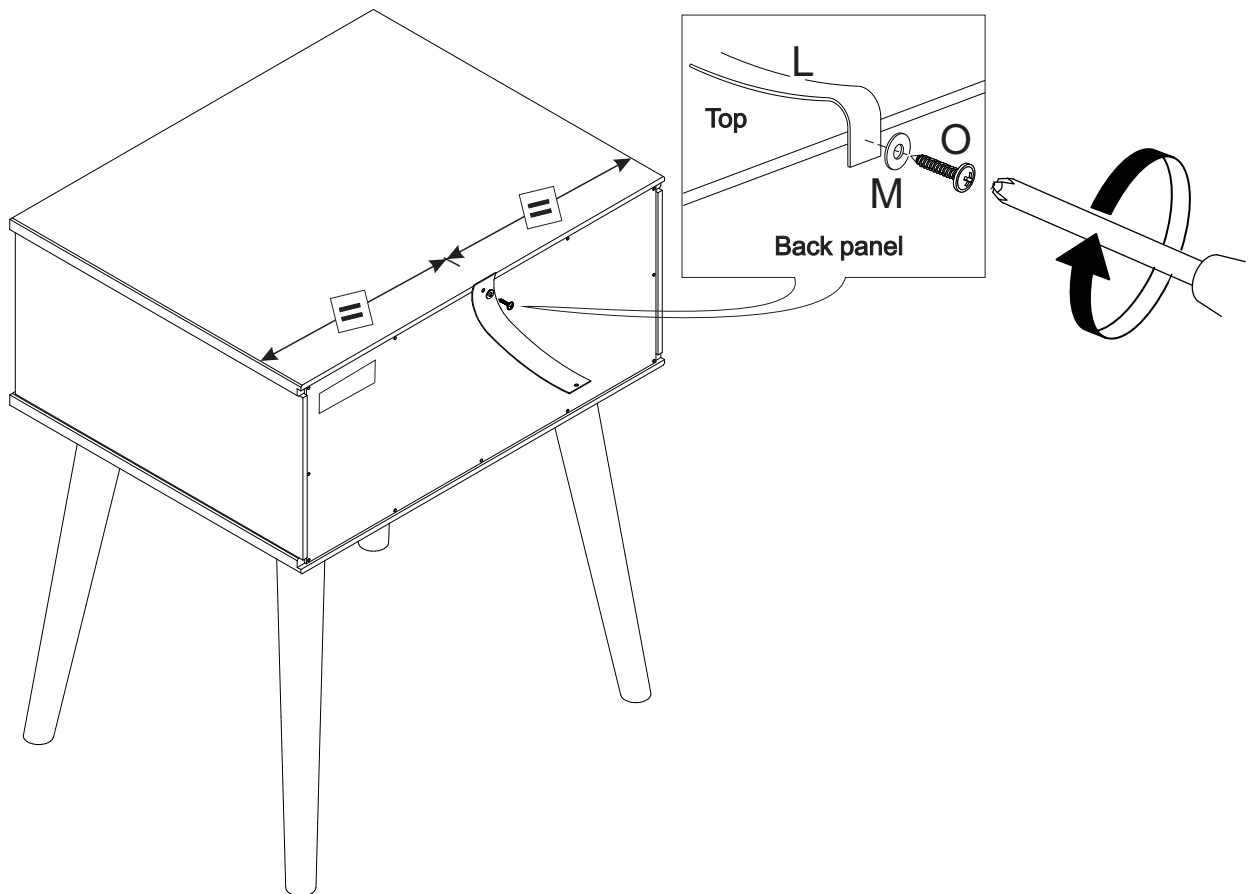

# Step 20

Insert the Plastic bush (N) into the wall. Then, secure the Wall Anchor (L) to the wall using a Washer (M) and Screw (E).

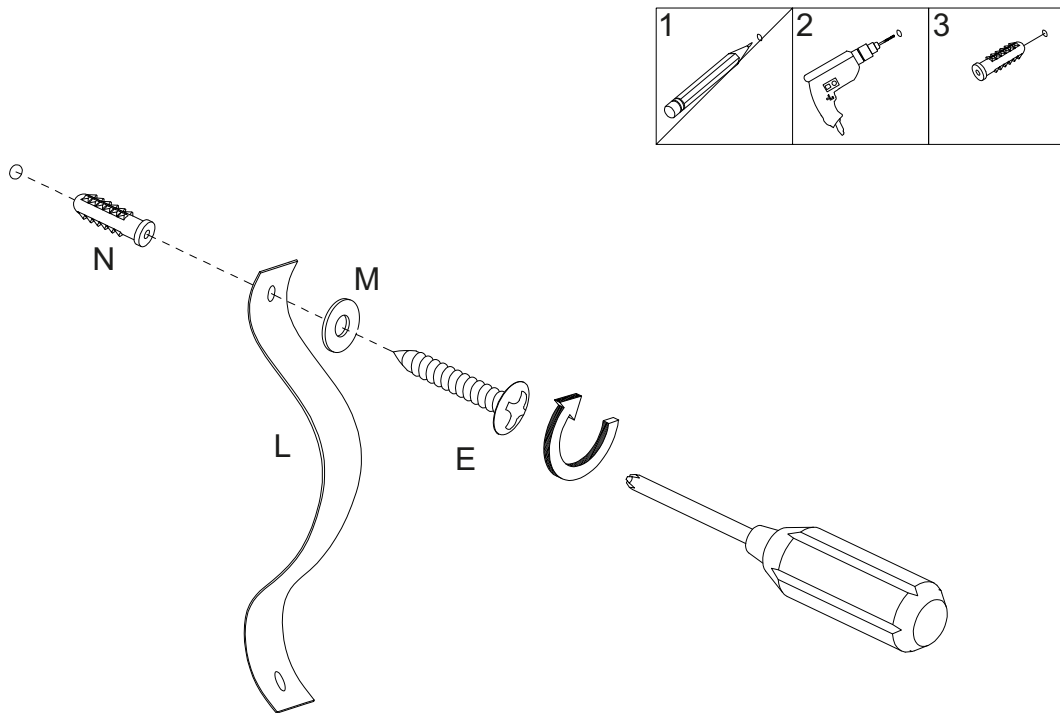

## Warning

Serious or fatal injuries can occur from furniture tipping over. To prevent the furniture from tipping over we recommend that it is permanently fixed to the wall. Wall anchor and hardware are included with this product. Please make sure hardware is suitable for your walls before installing, as different wall materials may require different types of anchors.

Name and address information for the manufacturer responsible for the anti-tip hardware and date of production can be found on the label on the back of the furniture.

You did it! Enjoy your new Nightstand!

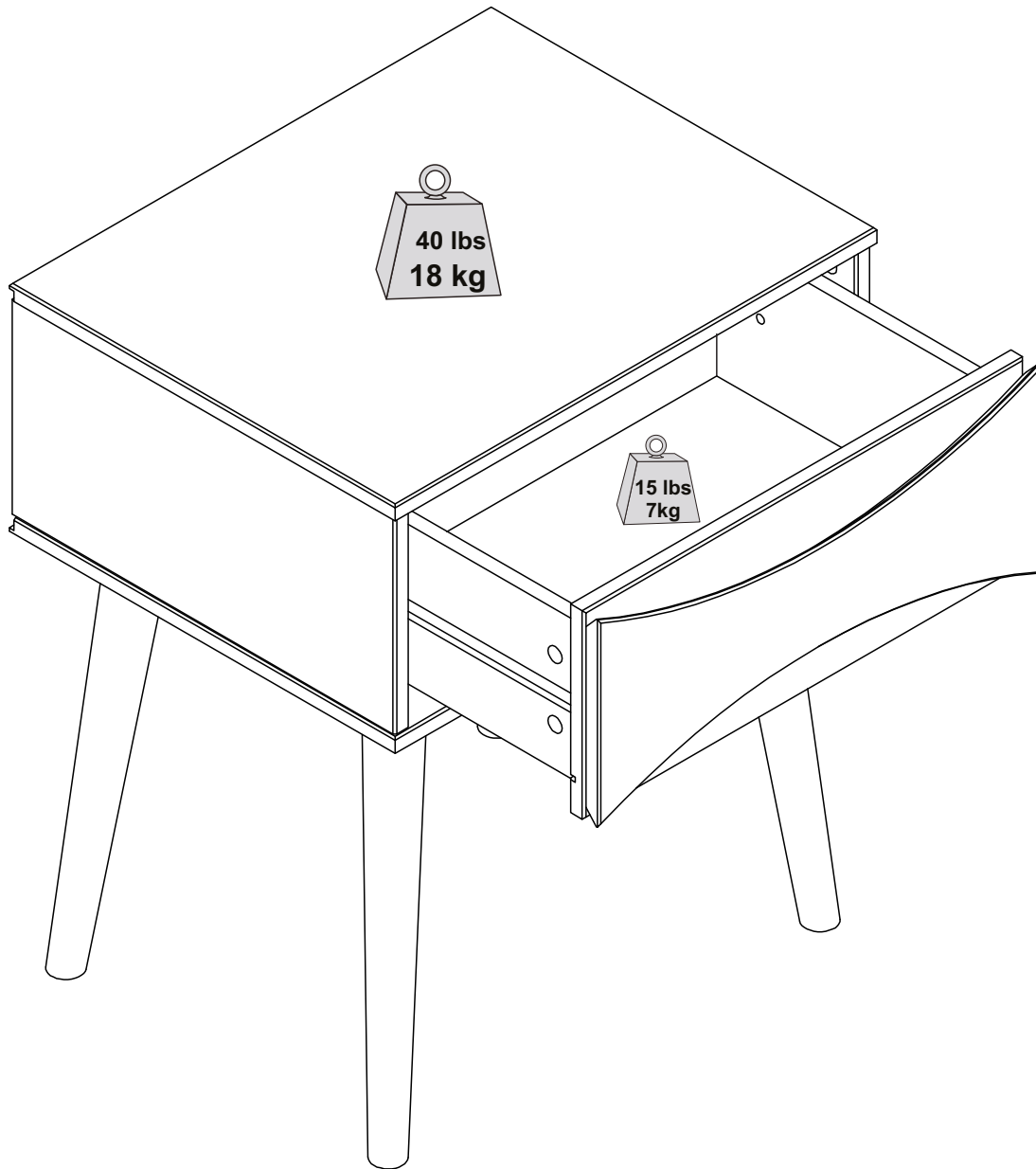

Congratulations on your new piece of furniture!  
We would love to hear about it and see it.  
Please leave us a review or post a picture with  
[#mywalkerredisonhome](#)

# Assembling furniture can be tricky sometimes.

Our customer service team, located in Utah, is here for product information, help assembling a product, or for any other customer support issue

Call us at **801-433-3008**

Email us at [service@walkeredison.com](mailto:service@walkeredison.com)

Visit our Customer Service website at [walkeredison.com/pages/customer-service](http://walkeredison.com/pages/customer-service)

We are available to help Monday-Thursday 8am-5pm, Friday 8am-3pm MST

For details on Assembly Videos, Assembly Instructions, Replacement Parts, and Customer service,

**SCAN HERE**



For cleaning, never use abrasives, use a soft cloth and water with neutral soap to clean the furniture.

# WALKER EDISON™

Atticus Table de Chevet Moderne de Style  
Milieu du Siècle en Bois Massif  
Atticus Mesita de Noche Moderna estilo  
Mid-Century de Madera Maciza

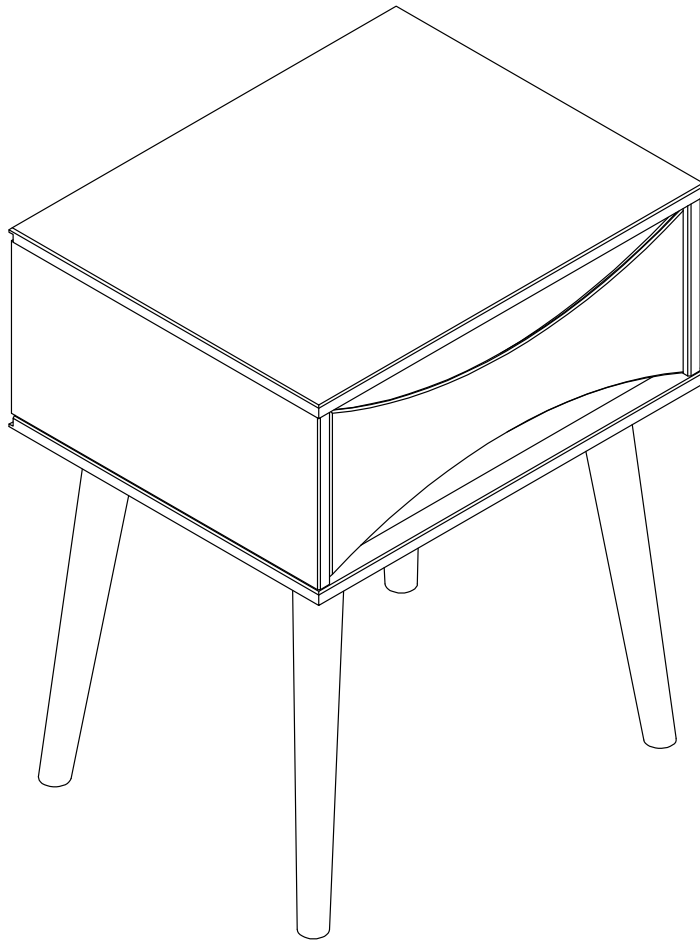

**Pour usage résidentiel seulement**

Visite notre site Web pour obtenir les instructions les plus récentes, des conseils d'assemblage, signaler des dommages ou commander des pièces. [www.walkerredison.com](http://www.walkerredison.com)

**Sólo para uso residencial**

Visite nuestro sitio web para consultar las últimas instrucciones, consejos de montaje, notificar daños o solicitar piezas. [www.walkerredison.com](http://www.walkerredison.com)

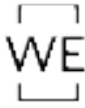

# Il est temps de commencer / Hora de empezar

Prépare un lieu de travail propre et souple pour éviter tout dommage lors de l'assemblage. Tu peux utiliser la boîte et les protections internes comme base. Vérifie également que tu disposes de toutes les pièces et parties avant de te lancer dans l'assemblage.

Prepare un lugar de trabajo limpio y blando para evitar daños durante el montaje. Puede utilizar la caja y las protecciones internas como base. Comprueba también que tiene todas las piezas y partes antes de sumergirse en el montaje.

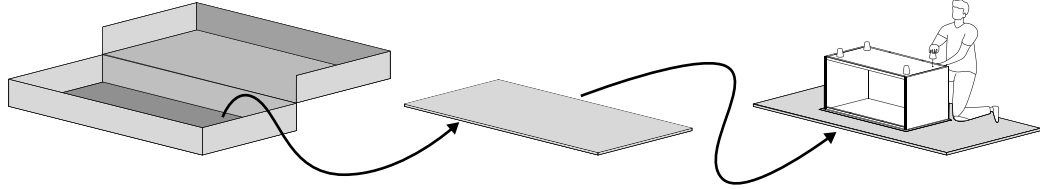

**Temps de montage  
estimé**  
**Tiempo estimado de  
montaje**

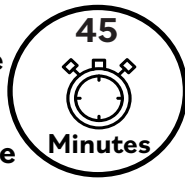

2 Personnes  
2 Personas

### Personnes recommandées pour le montage

Fais-en un effort d'équipe !  
Appelle un ami pour un  
assemblage plus rapide et plus  
facile.

### Personas recomendadas para el montaje

¡Hágalo en equipo!  
Llame a un amigo para que el  
montaje sea más rápido y sencillo.

### Outils nécessaires

Munis-toi d'un tournevis cruciforme pour réaliser cet assemblage. Tu auras également besoin d'un marteau pour t'aider.

### Herramientas requeridas

Tome un destornillador Phillips pour conquister este conjunto. También necesitaremos un martillo para ayudar.

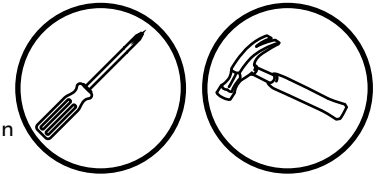

### Utilise les outils électriques avec précaution

Ce meuble est réalisé en Bois Massif et Bois Composite, des matériaux souples. Si tu choisis d'utiliser des outils électriques, règle-les sur le mode le plus lent. Fais attention à toi ! Les outils électriques peuvent provoquer des fissures ou endommager les meubles, mais aussi les autres composants s'ils sont mal utilisés. Les dommages causés par un outil électrique ne sont pas couverts par la garantie Walker Edison.

### Utilice las herramientas eléctricas con cuidado.

Este mueble está fabricado con madera maciza y madera compuesta, materiales blandos. Si decide utilizar herramientas eléctricas, ajústelas al ajuste más lento. Tenga cuidado. Las herramientas eléctricas pueden causar grietas o daños en el mueble, pero también en los herrajes si se utilizan mal. Los daños causados por una herramienta eléctrica no están cubiertos por la garantía de Walker Edison.

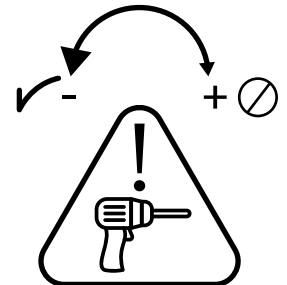

### Attention avec la glissière

Tes meubles possèdent des glissières en bois très résistantes. De temps en temps, nous recommandons d'appliquer de la paraffine ou de la cire de bougie standard pour améliorer la glisse des curseurs.

### Cuidado con las guías

Tus muebles cuentan con guías de madera de alta durabilidad. De vez en cuando, recomendamos la aplicación de parafina o cera estándar para mejorar el deslizamiento de los deslizadores.

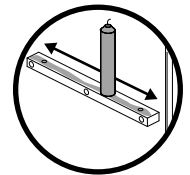

**Scannez pour obtenir des conseils d'assemblage et de l'aide !**

**¡Escanee para obtener consejos de montaje y ayuda!**







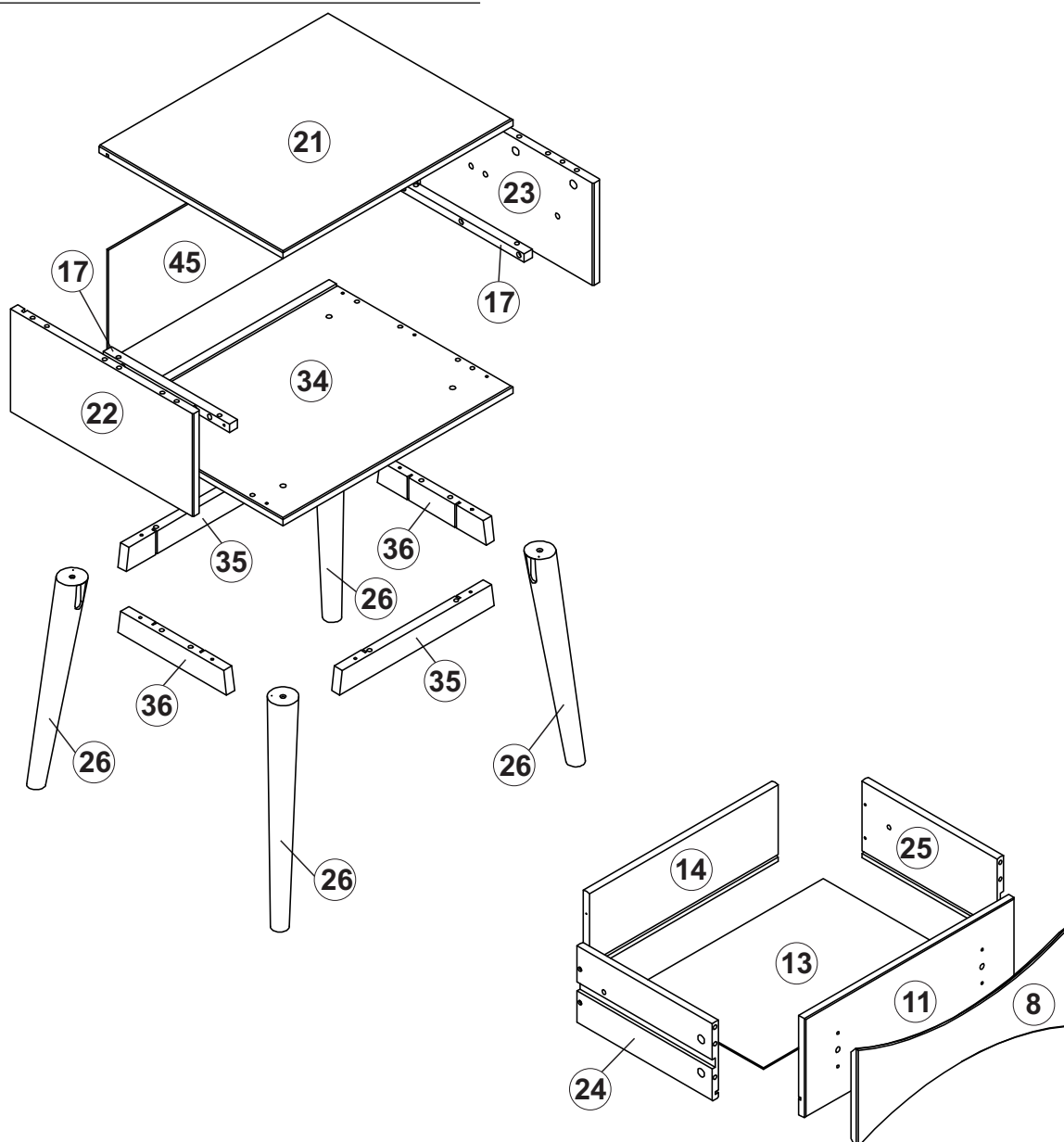

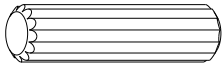
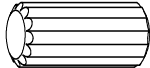

# Liste de pièces / Lista de piezas

Nombre de pièces Número de pieza	Description Descripción	Quantité Cantidad
8	Façade du Tiroir Frente del Cajón	1
11	Façade du Tiroir Frente del Cajón	1
13	Fond du Tiroir Fondo del Cajón	1
14	Arrière du Tiroir Parte Trasera del Cajón	1
17	Glissières en Bois Corredera de Madera	2
21	Panneau Supérieur Panel Superior	1
22	Panneau Gauche Panel Izquierdo	1
23	Panneau Droit Panel Derecho	1

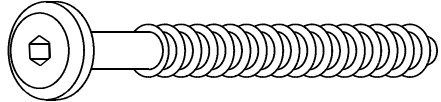
Nombre de pièces Número de pieza	Description Descripción	Quantité Cantidad
24	Côté Gauche du Tiroir Lado Izquierdo del Cajón	1
25	Côté Droit du Tiroir Lado Derecho del Cajón	1
26	Pied Pie	4
34	Panneau Inférieur Panel Inferior	1
35	Traverse Avant du Pied Travesaño Delantero del Pie	2
36	Traverse Lateral del Pie Travesaño Lateral del Pie	2
45	Panneau Arrière Panel Trasero	1

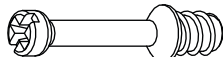

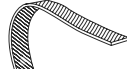
# Liste de composants / Lista de hardware

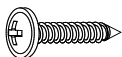
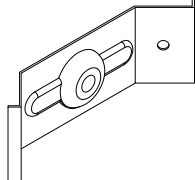
Parte Parte	Taille Tamaño	Nom Nombre	Quantité Cantidad
A 	Ø8*30mm	Cheville Espiga	26
B 	Ø10*20mm	Cheville Espiga	08
C 	Ø4,0*25mm	Vis Tornillo	10
D 	Ø3,5*30mm	Vis Tornillo	04
E 	Ø4,0*40mm	Vis Tornillo	15
G 	Ø7,0*50mm	Vis Tornillo	08
H 	4mm	Clé Allen Llave Allen	01
I 	Ø8*40mm	Cheville Espiga	02
J 	Ø15*30mm	Goujon de Assemblage Conectores	10
K 	Ø15*10mm	Boitier de Assemblage Trabas del Conector	10
L 		Courroie d'ancrage Anclaje de Pared	01
M 		Rondelle Arandela	02
N 	Ø6*35mm	Douille en Plastique Casquillo de Plástico	01
O 	Ø4*16mm	Vis Tornillo	09
P 		Support Soporte	04

*Les quantités de composants indiquées ci-dessus sont nécessaires pour un assemblage correct.*

*Des pièces supplémentaires peuvent être incluses.*

*Las cantidades de tornillería indicadas anteriormente son necesarias para un montaje correcto.*

*Se pueden incluir piezas de ferretería adicionales.*

# Étape / Paso 1

(FR)

Commençons! Insérez les Chevilles (B) dans le Façade du Tiroir (8) et Glissières en Bois (17).

(ES)

¡Manos a la obra! Inserta las Espigas (B) en la Frente del Cajón (8) y Correderas de Madera (17).

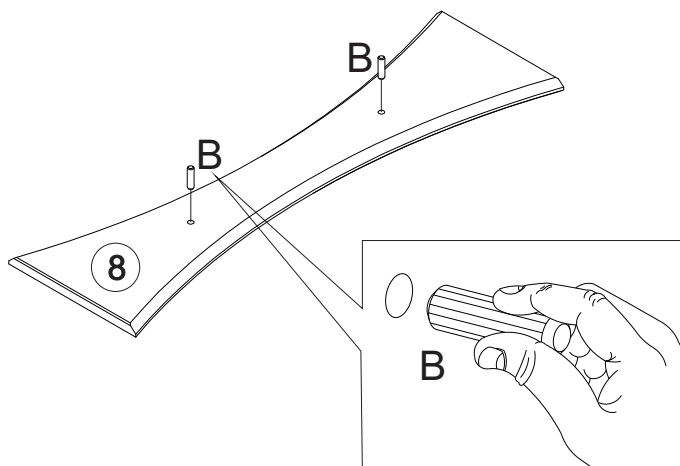
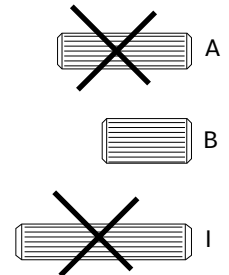
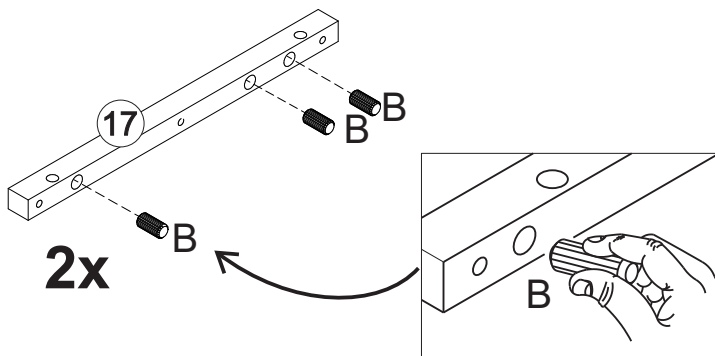

Tip

## Cheville en bois

Les chevilles sont essentielles lors de l'assemblage de meubles pour créer des connexions solides et précises. Elles garantissent l'intégrité structurelle, empêchent les déplacements et simplifient l'alignement, ce qui permet d'obtenir des meubles plus résistants et plus durables. suis ces étapes :

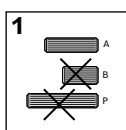

1: Sélectionne la taille de cheville appropriée en fonction de l'étape.  
1: Seleccione el tamaño de espiga adecuado según el paso.

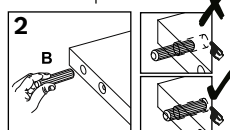

2: Insère dans le trou indiqué et appuie fermement pour assurer un positionnement correct.  
2: Insértela en el orificio indicado y presione firmemente para asegurar su correcta colocación.

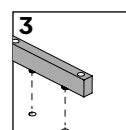

3: Alinee la cheville avec la pièce correspondante et enfonce-la jusqu'à ce qu'elle soit ferme.  
3: Alinee el pasador con la pieza correspondiente y presiónelo hasta que encaje.

## Espiga de madera

Las espigas son esenciales en el montaje de muebles para crear uniones fuertes y precisas.

Garantizan la integridad estructural, evitan el desplazamiento y simplifican la alineación, lo que se traduce en muebles más resistentes y duraderos.

Sigue estos pasos:

# Étape / Paso 2

(FR) Insérez les Chevilles (A) dans le Panneau Gauche (22), Panneau Droit (23), Côté Gauche du Tiroir (24), Côté Droit du Tiroir (25), Traverse Avant du Pied (35) et Traverse Latéral du Pied (36).

(ES) Inserta las Espigas (A) en el Panel Izquierdo (22), Panel Derecho (23), Lado Izquierdo del Cajón (24), Lado Derecho del Cajón (25), Travesaño Delantero del Pie (35) y Travesaño Lateral del Pie (36).

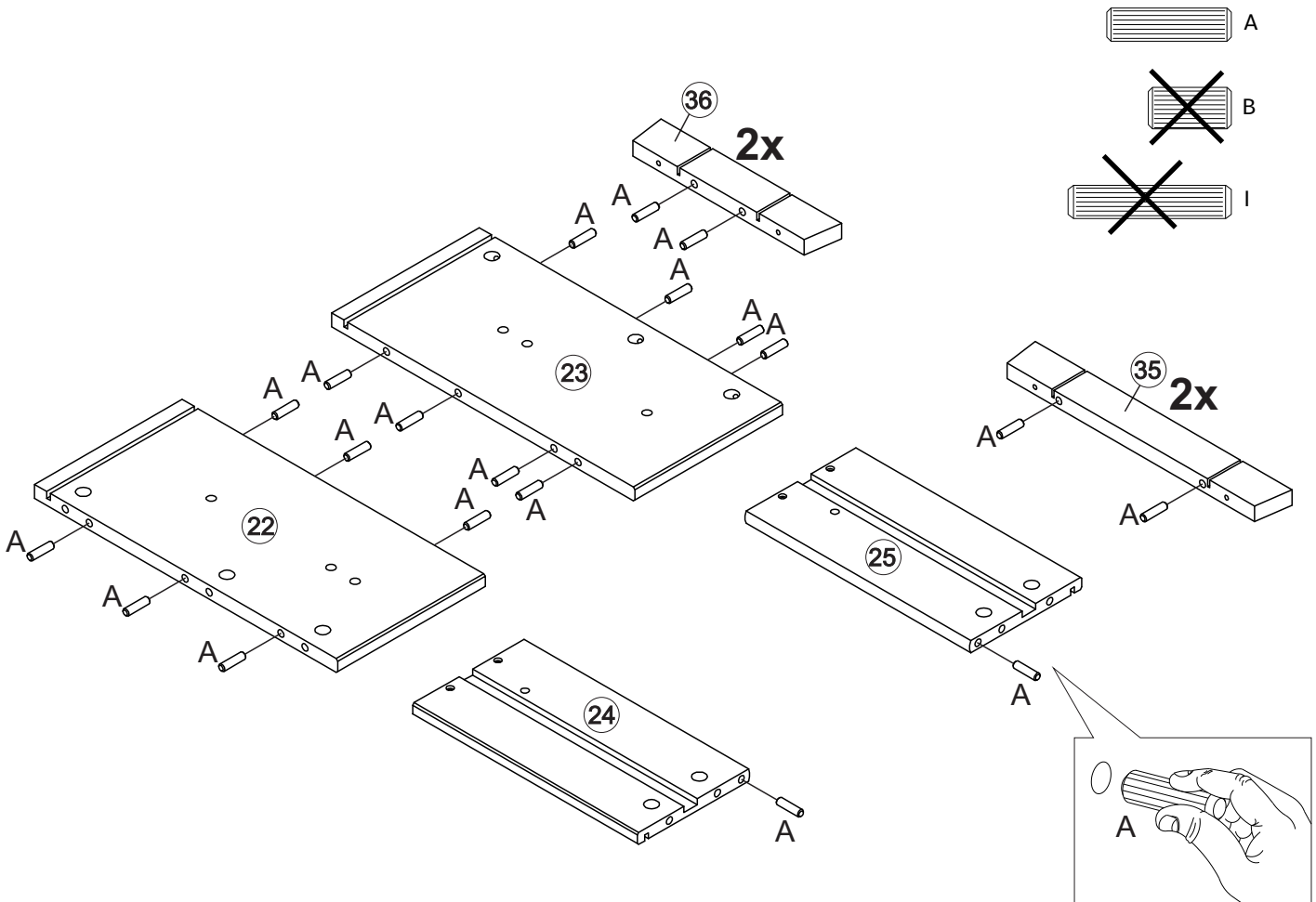

**Tip**  
Pour que ton produit conserve son meilleur aspect et sans rayures, essaie de le monter sur une surface souple telle qu'un tapis ou une couverture. Cela permet d'éviter les rayures accidentelles et de garder tes meubles en bon état!



Para mantener su producto con el mejor aspecto y sin arañazos, pruebe a montarlo sobre una superficie blanda, como una alfombra o una manta. Así evitará arañazos accidentales y mantendrá sus muebles en perfecto estado.

## Étape / Paso 3

(FR)

Attacher Goujon de Assemblage (J) dans le Façade du Tiroir (11) et Panneau Supérieur (21) utilisant un tournevis Phillips.

(ES)

Fije los Conectores (J) en la Frente del Cajón (11) y Panel Superior (21) utilizando un destornillador Phillips.

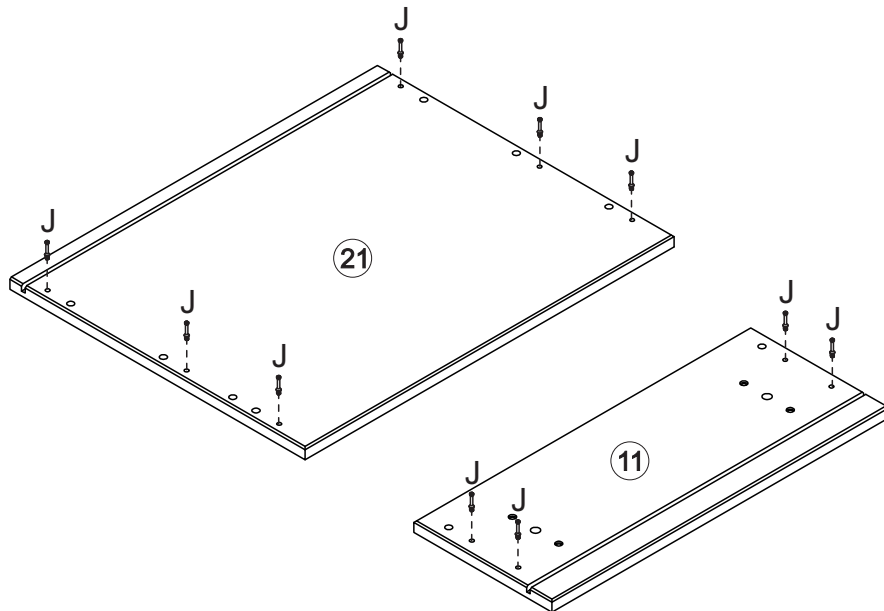
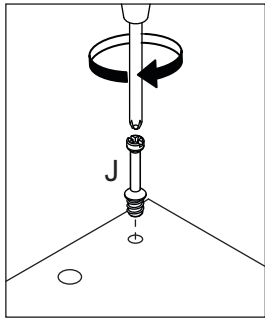

## Étape / Paso 4

(FR)

Fixez le Glissières en Bois (17) au Panneau Gauche (22) et Panneau Droit (23) avec les Vis (C) à l'aide d'un tournevis Phillips.

(ES)

Asegure la Corredera de Madera (17) al Panel Izquierdo (22) y al Panel Derecho (23) con Tornillos (C) usando un destornillador Phillips.

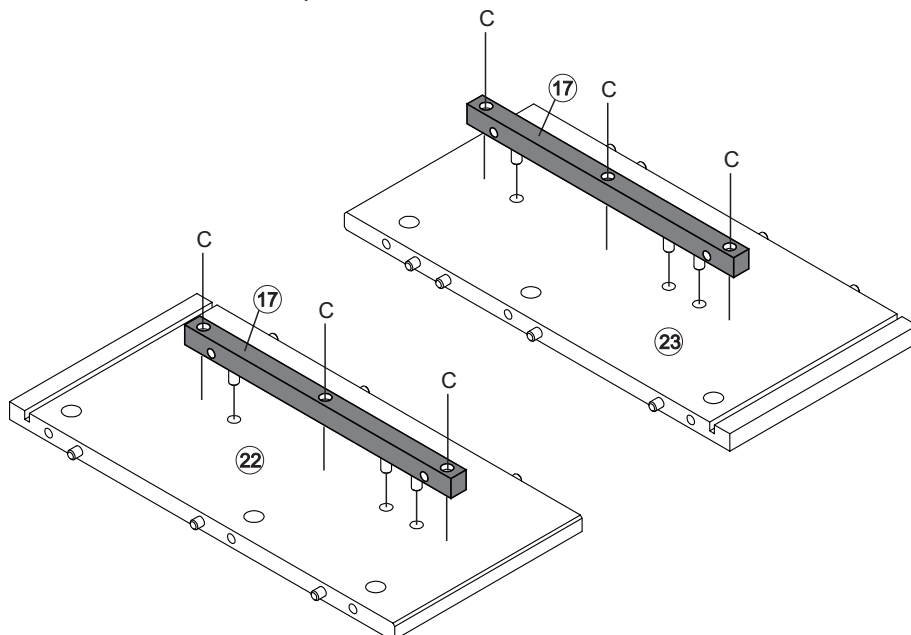

# Étape / Paso 5

(FR)

Fixez le Panneau Supérieur (21) au Panneau Gauche (22) et au Panneau Droit (23) avec des Boitier de Assemblage (K) à l'aide d'un tournevis Phillips.

(ES)

Adjunte el Panel Superior (21) al Panel Izquierdo (22) y Panel Derecho (23) usando las Trabas del Conector (K) y un destornillador Phillips.

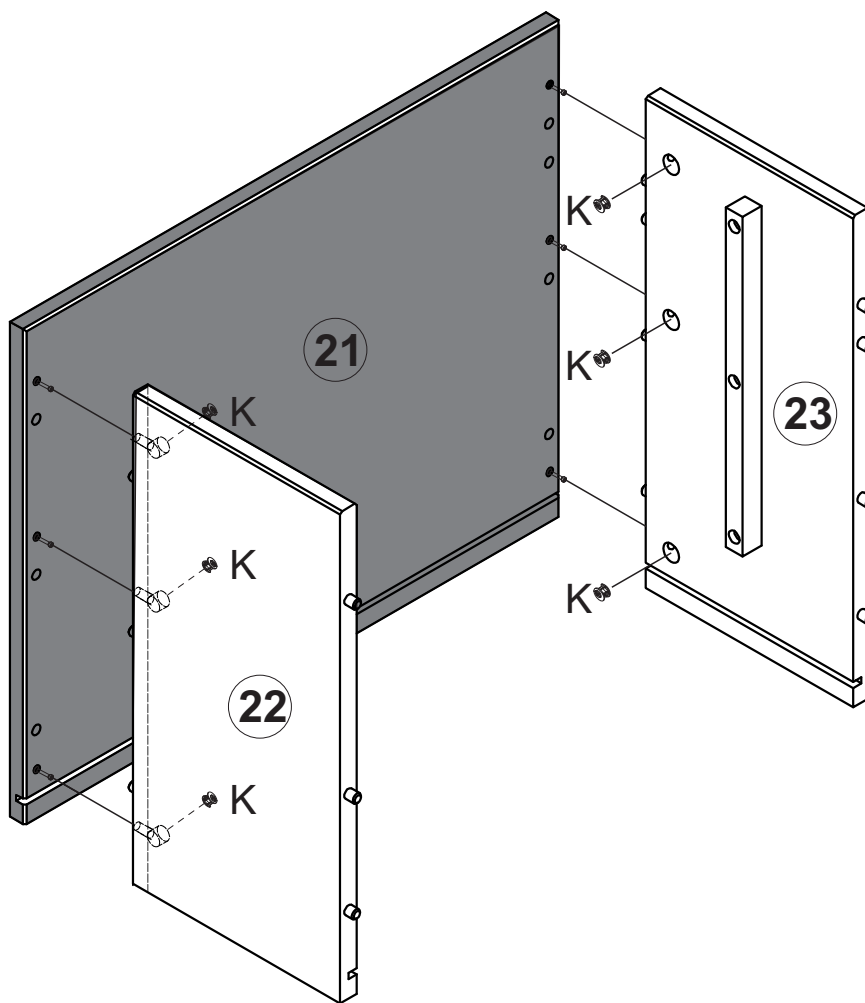
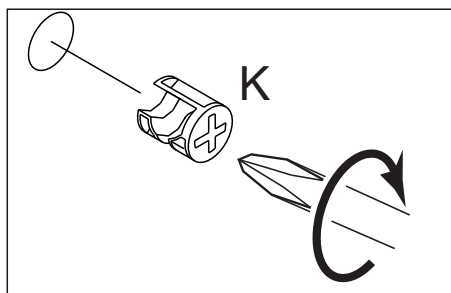

Tip

**Mini Fix**  
Mini Fix permet de joindre deux pièces en toute sécurité. Suis ces étapes simples.



1: Insère le Mini Fix dans les orifices du côté plat. Ne serre pas trop!  
1: Coloca el tornillo Mini Fix en los orifices del lado plano. ¡No aprietes demasiado!



2: Joins les pièces en bois. Les vis Mini Fix entrent dans les orifices qui ont des trous sur les côtés, tu dois pouvoir voir les vis Mini Fix à travers ceux-ci. Après avoir installé les pièces, insère le tambour Mini Fix dans les orifices latéraux.

2: Une las piezas de madera. Los tornillos Mini Fix entran en las piezas que tienen orificios en los lados, por lo que deberías poder ver los tornillos Mini Fix a través de ellos. Después de encajar las piezas, inserta el tambor del tornillo Mini Fix en los orificios laterales.



**Mini Fix**  
Los tornillos Mini Fix ayudan a unir de forma segura dos piezas. Sigue estas fáciles etapas.

3: Sur la partie arrière du tambour, il aura la forme d'un « C ». Insère le tambour de manière à ce que l'ouverture « C » se symboles à la vis Mini Fix. Serre-la avec le tournevis.  
3: La parte posterior del tambor tendrá la forma de « C ». Inserta el tambor de modo que la abertura de la « C » encaja en el tornillo Mini Fix. Apriétalo con un destornillador.

## Étape / Paso 6

(FR)

Attacher Traverse Avant du Pied (35) au Panneau Inférieur (34) utilisant Vis (E) et un tournevis Phillips.

(ES)

Monta el Travesaño Delantero del Pie (35) al Panel Inferior (34) usando el Tornillo (E) y un destornillador Phillips.

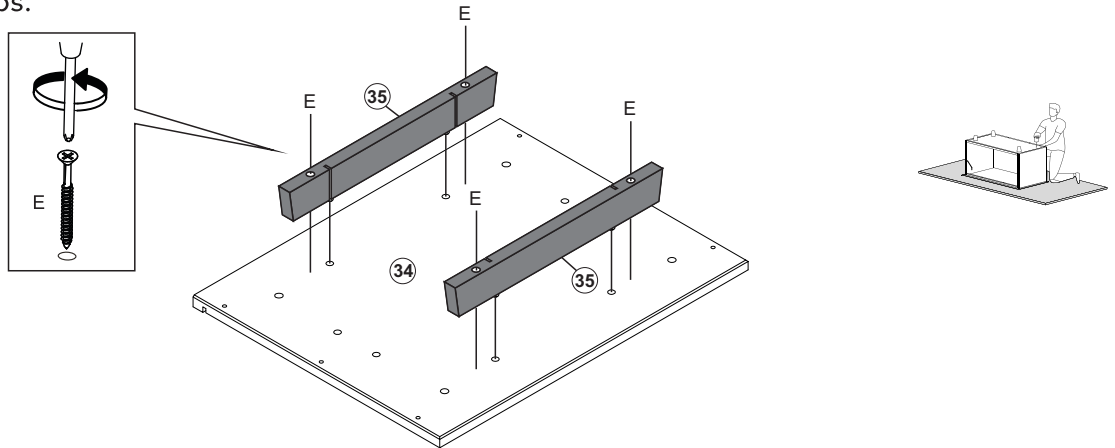

## Étape / Paso 7

(FR)

Insérez le Pied (26) sur Traverse Latéral du Pied (36) et insérez-le sur le Panneau Inférieur (34).

(ES)

Inserta el Pie (26) al Travesaño Lateral del Pie (36) y ensambla en el Panel Inferior (34).

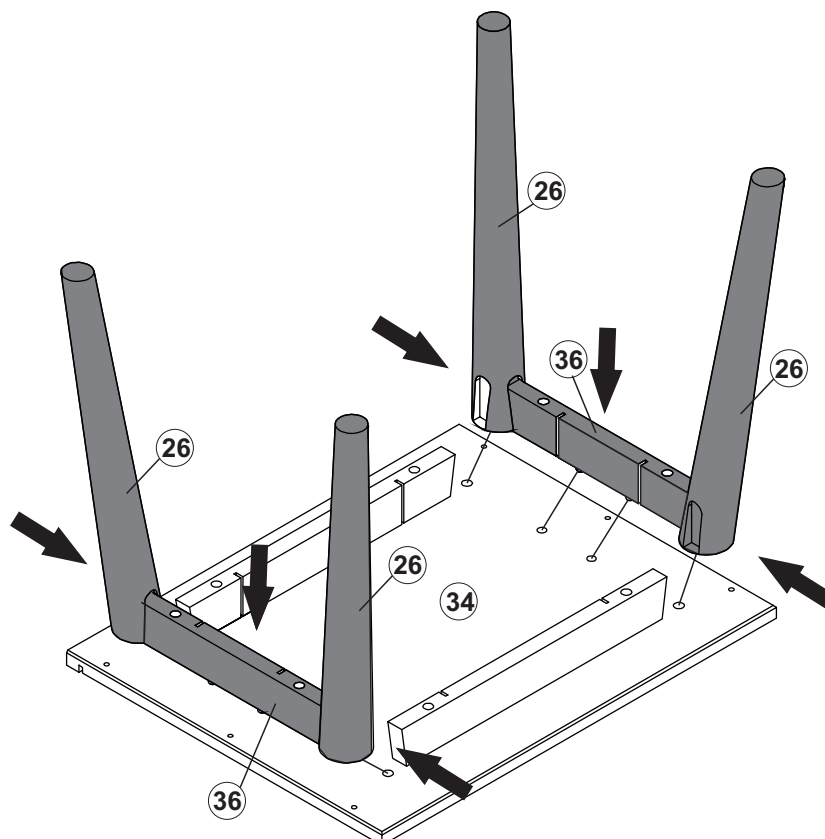

## Étape / Paso 8

(FR)

Fixez le Traverse Latéral du Pied (36) sur le Panneau Inférieur (34) avec les Vis (E) à l'aide d'un tournevis Phillips.

(ES)

Fije el Travesaño Lateral del Pie (36) al Panel Inferior (34) utilizando el Tornillos (E) y un destornillador Phillips.

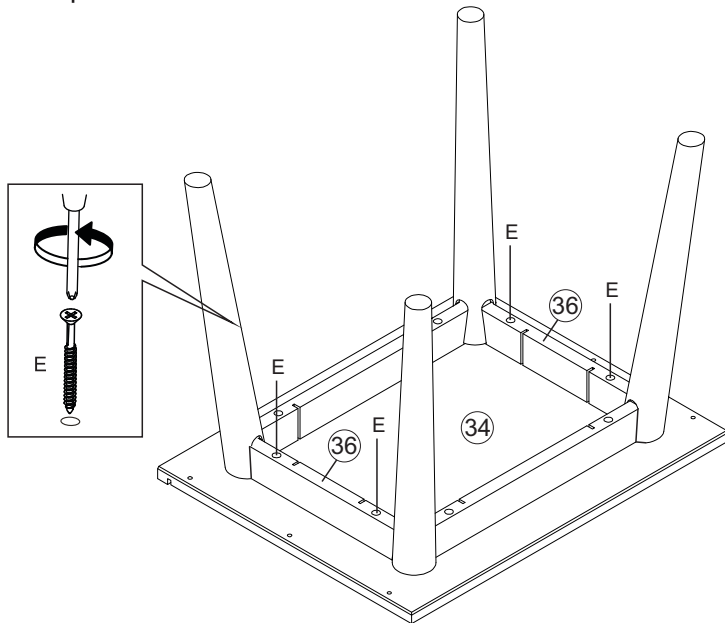

## Étape / Paso 9

(FR)

Fixez le Support (P) au Panneau Inférieur (34).

(ES)

Encaje el Soporte (P) en el Panel Inferior (34).

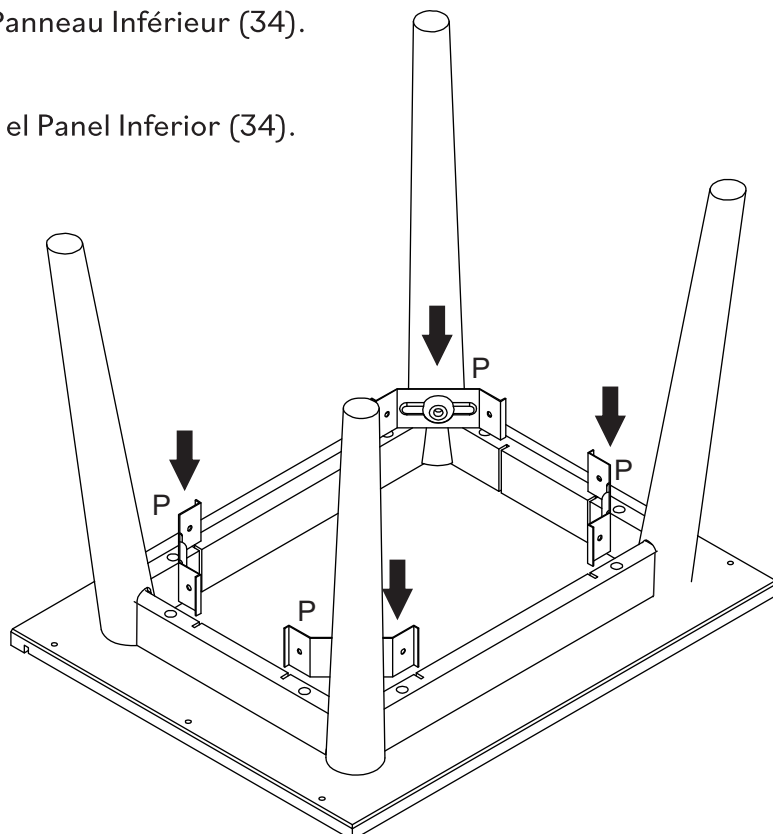

# Étape / Paso 10

(FR)

Attacher les Supports (P) au Panneau Inférieur (34) assemblée avec les Vis (O) à l'aide d'un tournevis Phillips.

(ES)

Adjunte el Soporte (P) al Panel Inferior (34) ensamblado usando el Tornillo (O) y un destornillador Phillips.

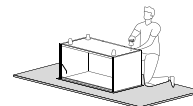
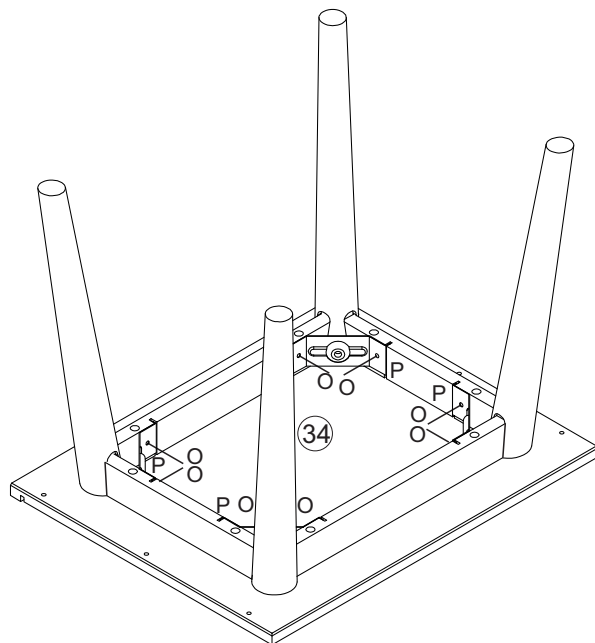

# Étape / Paso 11

(FR)

Insérez les Vis (G) dans le Support (P) à l'aide d'une Clé Allen (H).

(ES)

Fije los Tornillos (G) em el Soporte (P) utilizando la llave Allen (H).

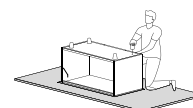
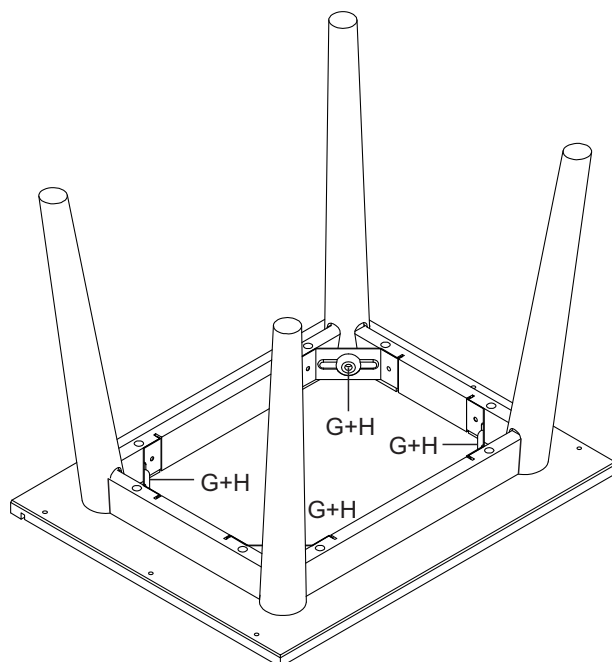

# Étape / Paso 12

(FR) Fixez le Pied (26) au Panneau Inférieur (34) avec les Vis (G) à l'aide d'une clé Allen (H).

(ES) Fije el Pie (26) al Panel Inferior (34) usando el Tornillo (G) y la llave Allen (H).

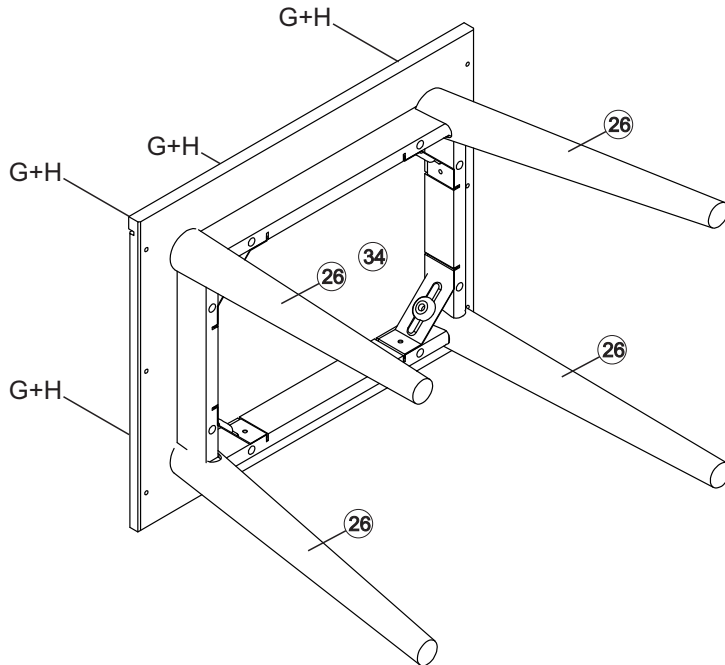

# Étape / Paso 13

(FR) Insérez le Panneau Arrière (45) entre le Panneau Gauche (22) et le Panneau Droit (23). Fixez le Panneau Inférieur (34) au Panneau Gauche (22) et au Panneau Droit (23) avec les Vis (E) à l'aide d'un tournevis Phillips.

(ES) Inserta el Panel Trasero (45) entre el Panel Izquierdo (22) y Panel Derecho (23). Fija el Panel Inferior (34) al Panel Izquierdo (22) y al Panel Derecho (23) usando el Tornillo € y un destornillador Phillips.

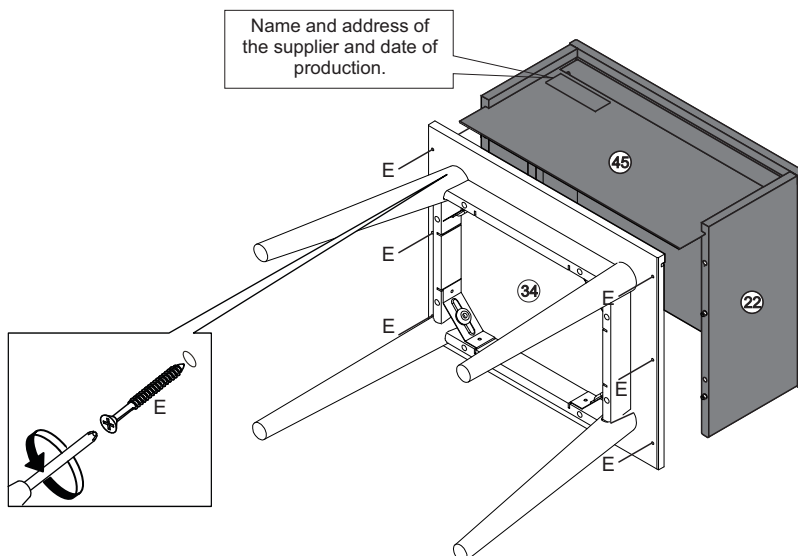

# Étape / Paso 14

(FR)

Fixez la Façade du tiroir (8) à la Façade du tiroir (11) avec les Vis (C) à l'aide d'un tournevis Phillips.

(ES)

Fije la Frente del Cajón (8) en la Frente del Cajón (11) usando el Tornillo (C) y un destornillador Phillips.

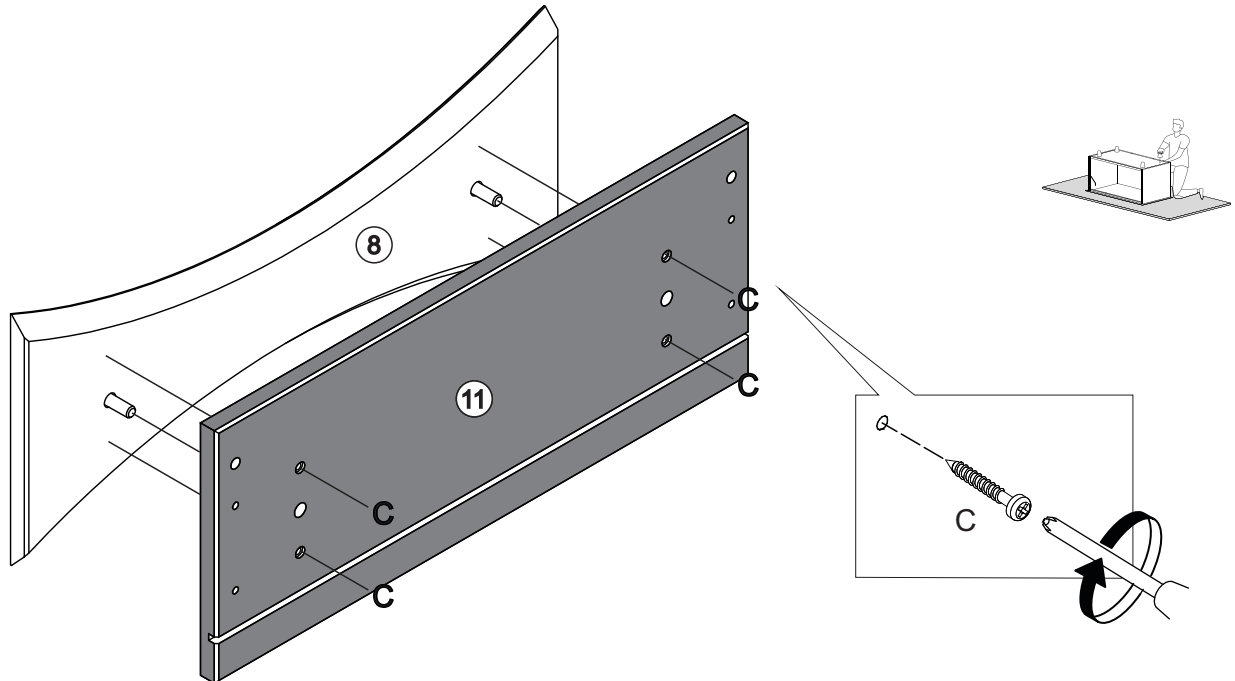

# Étape / Paso 15

(FR)

Fixez le Côté Gauche du tiroir (24) et le Côté Droit du tiroir (25) à la Façade du tiroir (11) avec des Boîtiers de Assemblage (K) à l'aide d'un tournevis Phillips.

(ES)

Fije la Lateral Izquierda del Cajón (24) y la Lateral Derecho del Cajón (25) en la Frente del Cajón (11) aprietando las Trabas del Conector (K) con un destornillador Phillips.

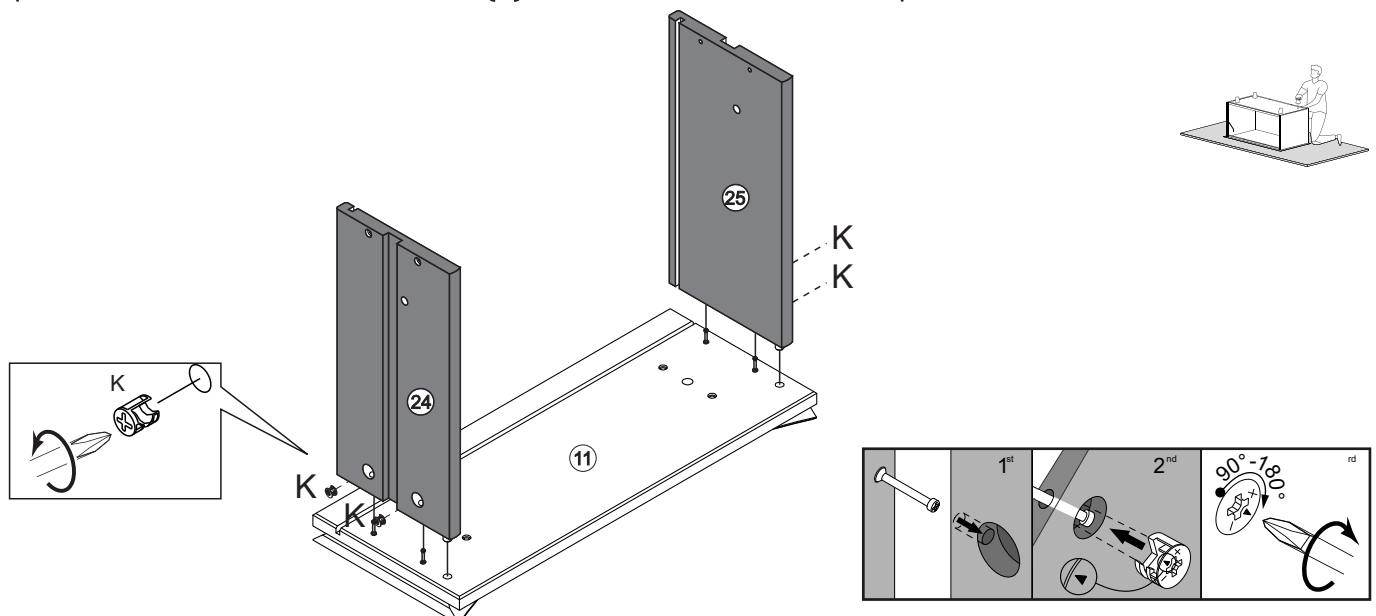

## Étape / Paso 16

(FR)  
Insérez le Fond du Tiroir (13) entre les rainures du Côté Gauche du Tiroir (24) et du Côté Droit du Tiroir (25). Fixez l'Arrière du Tiroir (14) au Côté Gauche du Tiroir (24) et au Côté Droit du Tiroir (25) avec les Vis (D) à l'aide d'un tournevis Phillips.

(ES)  
Inserta el Fondo del Cajón (13) en las ranuras de los Lados Derecho e Izquierdo del Cajón (24,25). Fije la Parte Trasera del Cajón (14) en los dos lados usando el Tornillo (D) y un destornillador Phillips.

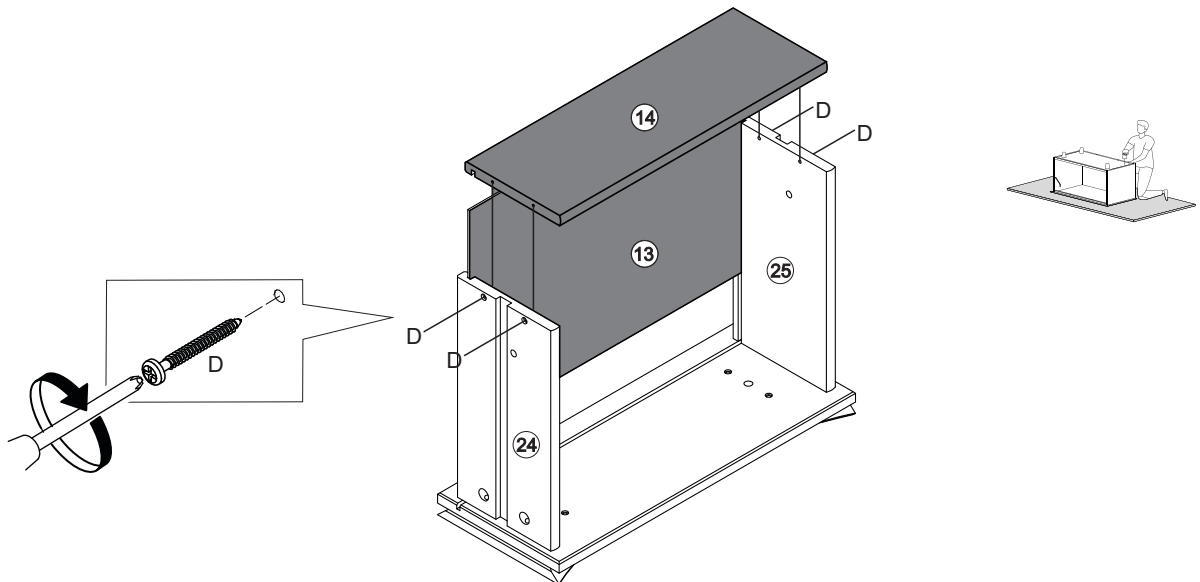

## Étape / Paso 17

(FR)  
Insérez le Cheville (A) dans la Glissière en Bois (17) pour constituer la butée du tiroir.

(ES)  
Inserta las Espigas (A) en la Corredera de Madera (17) para ser el tope del cajón.

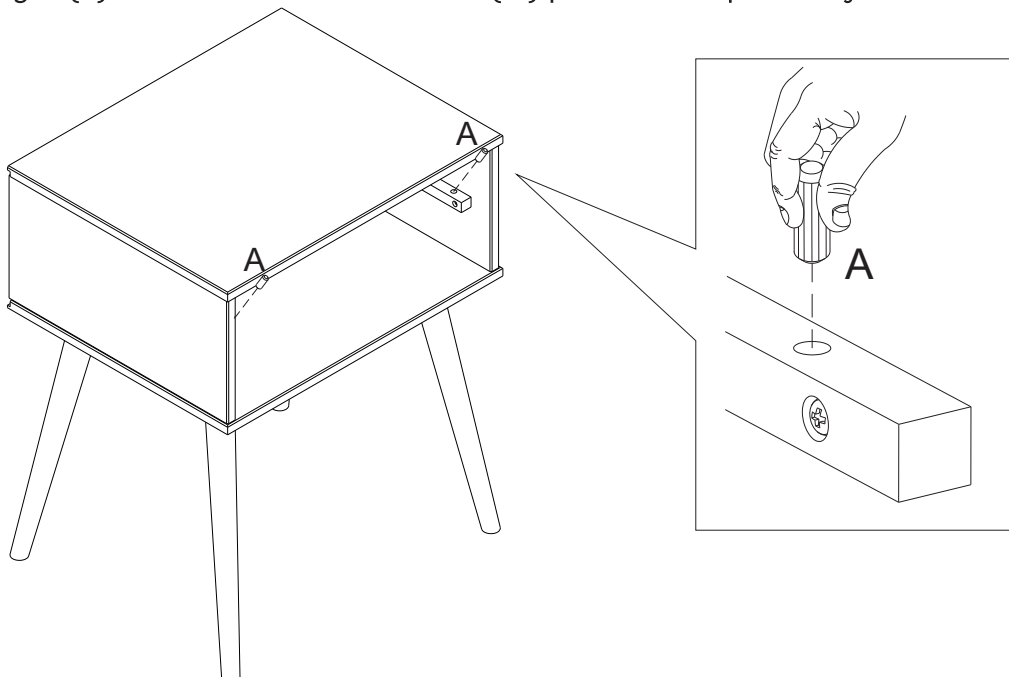

## Étape / Paso 18

(FR)

Insérez la Cheville (I) à l'intérieur de tous les tiroirs, le tiroir étant à l'intérieur de l'unité après avoir passé la cheville en bois qui se trouve dans la glissière du tiroir. La cheville n'est pas alignée avec le panneau, elle se trouve un peu à l'intérieur du tiroir pour vous aider lorsque vous devez retirer la cheville de verrouillage pour retirer le tiroir.

(ES)

Inserte la Espiga (I) en el interior de todos los cajones, con el cajón dentro de la unidad después de haber pasado las espigas que se encuentran en el deslizador del cajón. La espiga no está al ras con el panel, está un poco dentro del cajón para ayudar cuando necesite quitar la espiga de bloqueo para quitar el cajón.

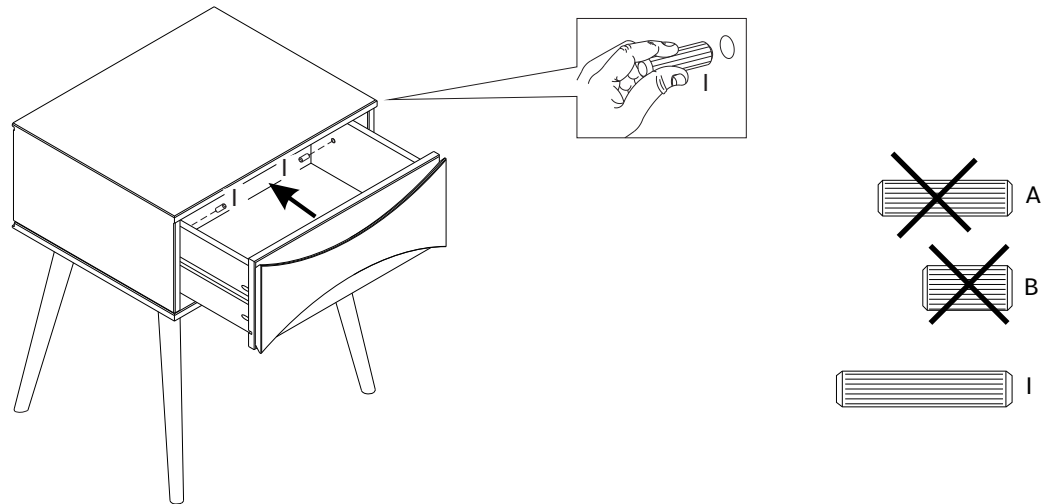

## Étape / Paso 19

(FR)

Pour finir, fixons votre table de chevet au mur ! Fixez l' Courroie d'ancrage (L) à votre table avec une Rondelle (M) et une Vis (O) à l'aide d'un tournevis Phillips.

(ES)

Para terminar esto, ¡aseguremos su mesita de noche a la pared! Fije el Anclaje de Pared (L) a su mesita con una Arandela (M) y un Tornillo (O) usando un destornillador Phillips.

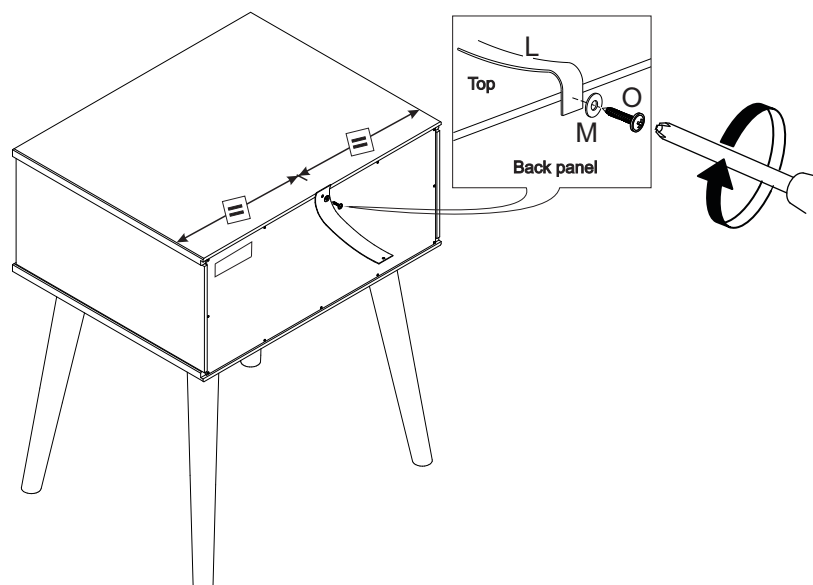

# Step 20

(FR)

Insérez la Douille en Plastique (N) dans le mur. Ensuite, fixez l'Courroie d'ancrage (L) au mur à l'aide d'une Rondelle (M) et d'une Vis (E).

(ES)

Inserte el Casquillo de Plástico (N) en la pared. Luego, fije el Anclaje de Pared (L) a la pared usando una Arandela (M) y un Tornillo (E).

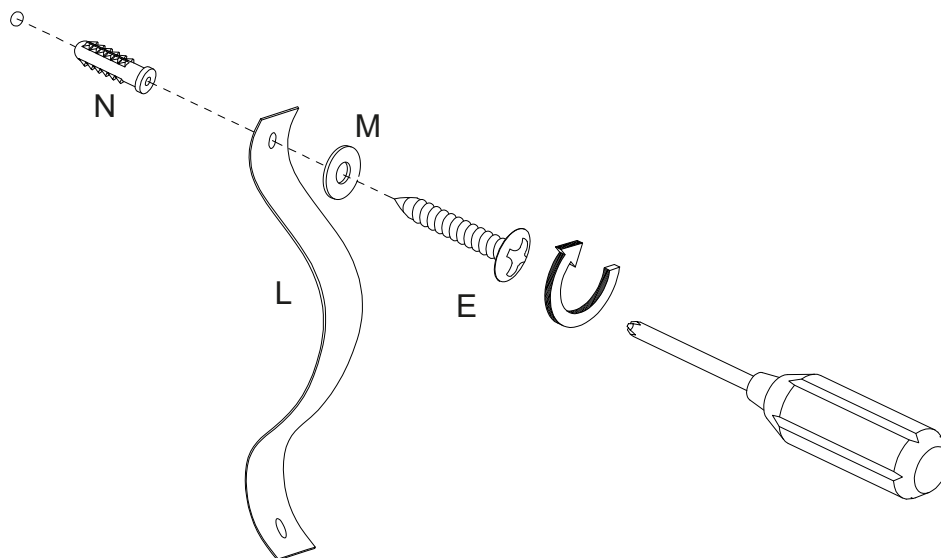
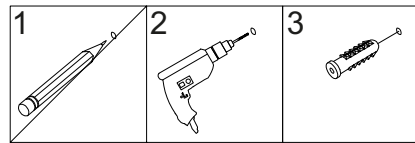

## Warning

Serious or fatal injuries can occur from furniture tipping over. To prevent the furniture from tipping over we recommend that it is permanently xed to the wall. Wall anchor and hardware are included with this product. Please make sure hardware is suitable for your walls before installing, as different wall materials may require different types of anchors.

Name and address information for the manufacturer responsible for the anti-tip hardware and date of production can be found on the label on the back of the furniture.

Tu as réussi ! Profite de ton nouveau Nighstand!  
¡Lo ha conseguido! ¡Disfrute de su nueva Nightstand!

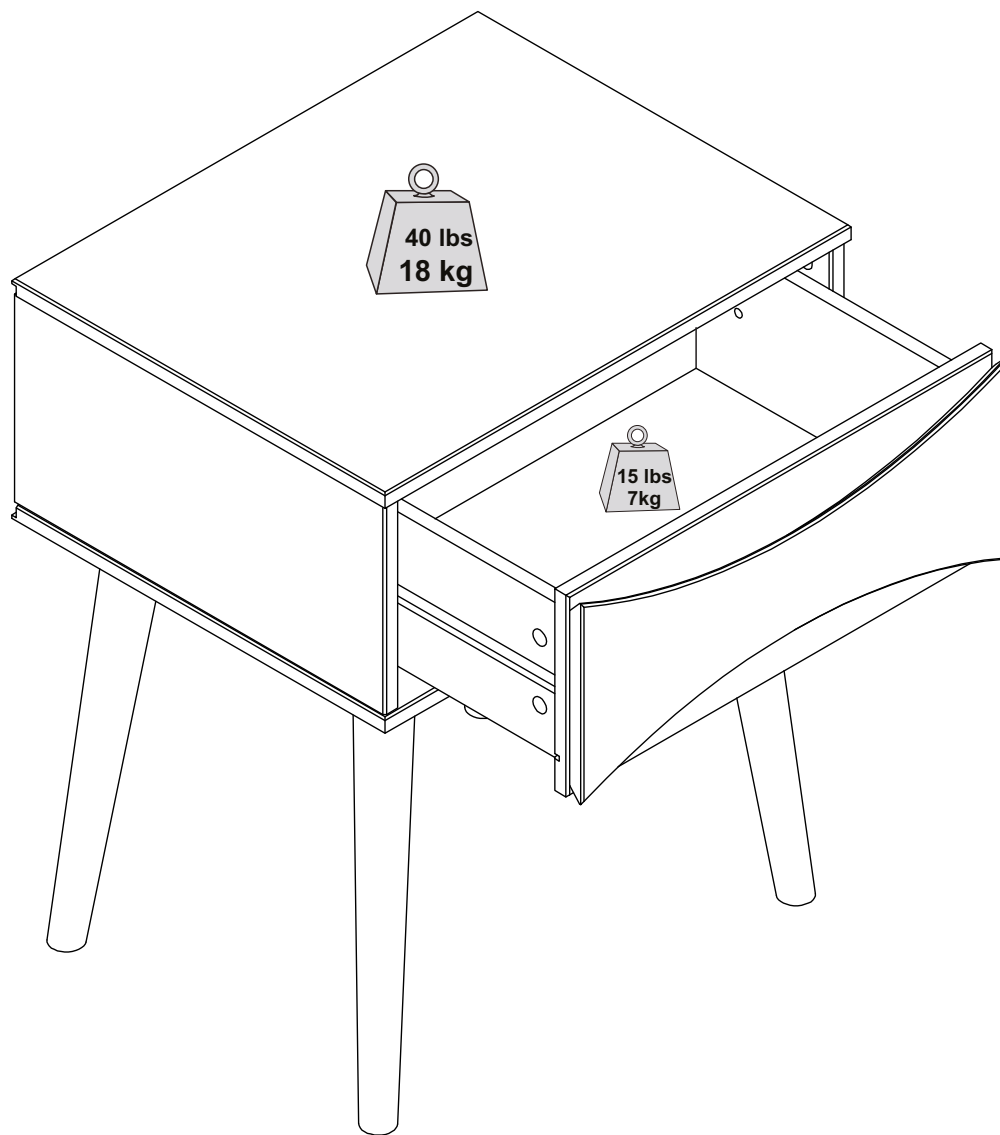

**Bravo pour ton nouveau meuble !**

Nous aimerions t'en entendre parler et le voir.

S'il te plait, laisse-nous un commentaire ou publie une photo sur

**#mywalkerredisonhome**

**¡Enhorabuena por sus nuevos muebles!**

Nos encantaría oírlo y verlo.

Por favor, déjenos un comentario o publique una foto con

**#mywalkerredisonhome**

## Assembler des meubles peut parfois être compliqué.

Notre équipe de service client, située dans l'Utah, est là pour obtenir des informations sur les produits, aider pour l'assemblage d'un produit ou pour tout autre problème de support client.

Appelle-nous **801-433-3008**

Envoie-nous les e-mails à [service@walkeredison.com](mailto:service@walkeredison.com)

[walkeredison.com/pages/customer-service](http://walkeredison.com/pages/customer-service)

Nous sommes disponibles pour t'aider du Lundi au Jeudi de 8 am - 5 pm, Vendredi de 8 am - 3 pm MST.

Pour plus de détails sur les vidéos d'assemblage, les instructions d'assemblage, les pièces de rechange et le service client.

**NUMÉRISER ICI.**



Pour le nettoyage, n'utilise jamais d'abrasifs, utilise un chiffon doux et de l'eau avec du savon neutre pour nettoyer les meubles.

## A veces, montar muebles puede resultar complicado.

Nuestro equipo de atención al cliente, ubicado en Utah, está a su disposición para informarle sobre los productos, ayudarle a montarlos o resolver cualquier otro problema de atención al cliente.

Llámenos **801-433-3008**

Envíenos un correo electrónico a [service@walkeredison.com](mailto:service@walkeredison.com)

Visite nuestra página web de atención al cliente

[walkeredison.com/pages/customer-service](http://walkeredison.com/pages/customer-service)

Estamos a su disposición para ayudarle de lunes a jueves de 8:00 a 17:00, viernes de 8:00 a 15:00 MST.

Para más detalles sobre videos de montaje, instrucciones de montaje, piezas de recambio y servicio de atención al cliente

**ESCANEE AQUÍ**



Para la limpieza, nunca utilice productos abrasivos, utilice un paño suave y agua con jabón neutro para limpiar los muebles.