

Assembly Instructions

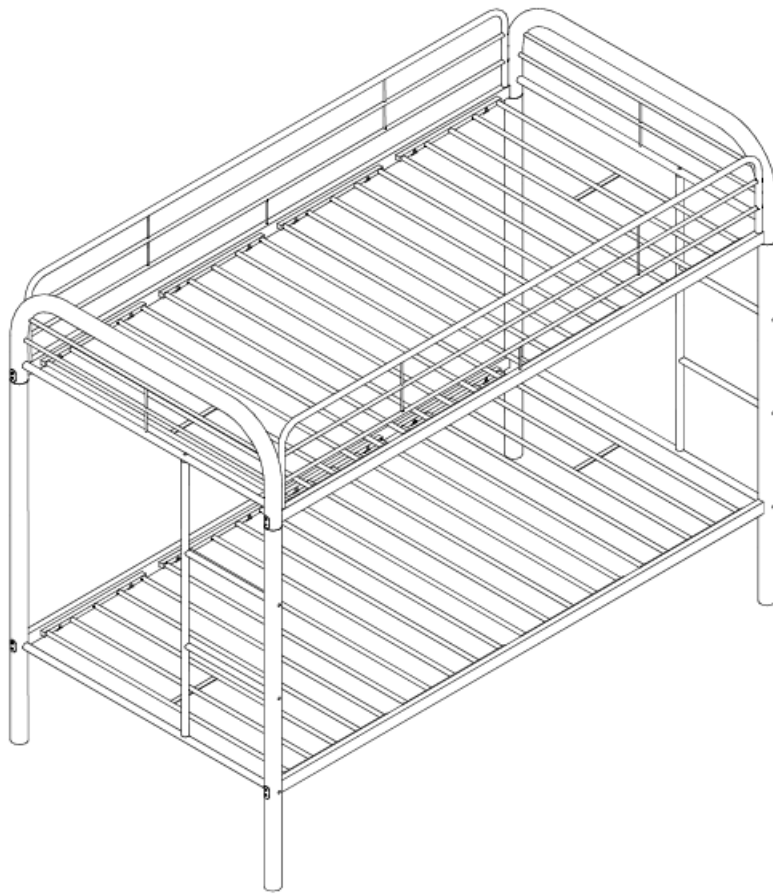

ASSEMBLY RATING

The Assembly Rating is a 5-point system that shows the degree of effort needed in assembling a specific product (with 1 being easy and 5 being difficult). For some products, two persons are recommended.

EASY  DIFFICULT

Tools Required for Assembly:

Allen Wrench

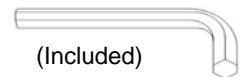

2 PERSONS RECOMMENDED

ASSEMBLY & CARE ADVICE

FOR YOUR FURNITURE TO LAST, CORRECT ASSEMBLY AND PROPER MAINTENANCE ARE NECESSARY. PLEASE FOLLOW THE INFORMATION PROVIDED BELOW TO FULLY ENJOY YOUR FURNITURE.

BASIC ASSEMBLY TECHNIQUES

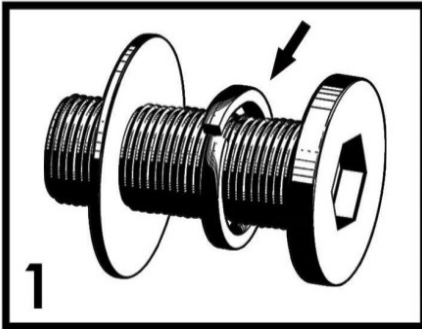

1 When lock or spring washer is used in an assembly, please make sure the lock or spring washer is placed between the larger flat washer and the head of the screw or bolt.



2 Position each part correctly and insert screws or bolts into their respective holes by hand tighten or using the proper hand tool. Only tighten when step is completed or when instructed to do so.

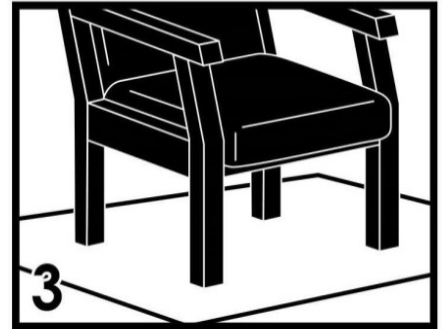

3 Use cardboard or carpet area when assembling furniture to prevent scratches. Make sure the furniture rests on a flat and level surface with each leg evenly touching the floor.

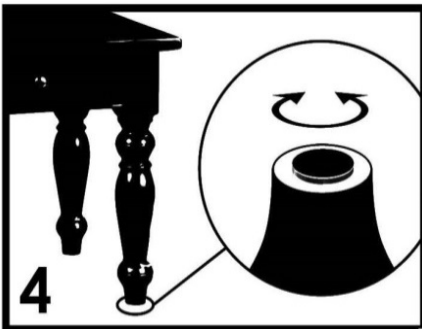

4 Some furniture comes with height adjustment knobs underneath each leg. To lower or to raise each leg, you need to turn clockwise or counterclockwise, respectively.

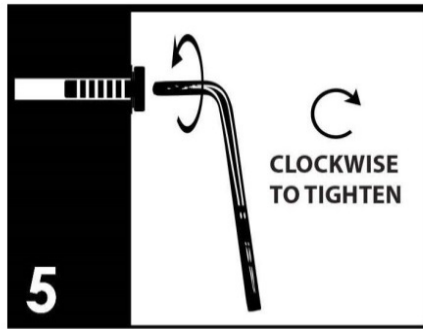

5 Make sure all parts are properly aligned, then use the appropriate hand tool to completely tighten the bolts or screws. Do not use power tools and do not overtighten.

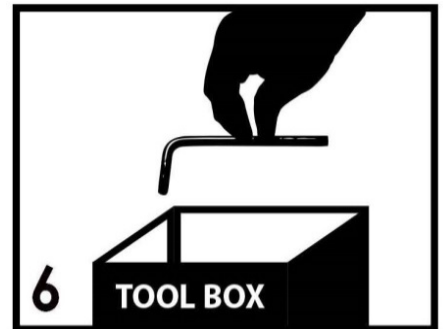

6 Save the instructions and store the Allen wrench or any supplied tool for later maintenance. After two weeks, check and tighten any loose hardware and repeat again every six months thereafter.

IT IS THE USER'S RESPONSIBILITY TO MAINTAIN THE FURNITURE. THE HARDWARE MAY LOOSEN OVER TIME AND MAY CAUSE THE FURNITURE TO BE WOBBLY AND UNABLE TO SUPPORT ITS INTENDED WEIGHT CAPACITY. THIS MAY LEAD TO COLLAPSE AND MAY CAUSE SERIOUS INJURY.



FAILURE TO FOLLOW THE GUIDELINES ABOVE MAY RESULT IN INJURY AND/OR PROPERTY DAMAGE.

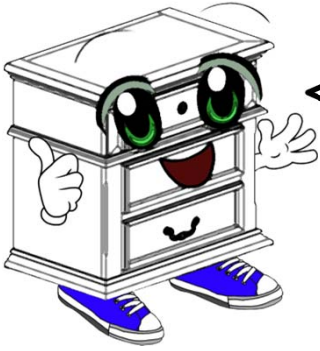

Before you begin, please read Page 2 for “Assembly and Care Advice” AND Page 7 for “Safety Warnings”.

And remember, do not tighten until each step is completed or instructed.

MD

Parts List

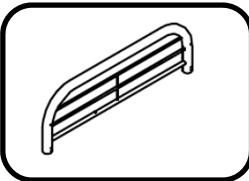

#1 x 1 pc
End Guardrail A

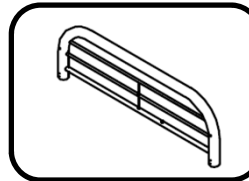

#2 x 1 pc
End Guardrail B

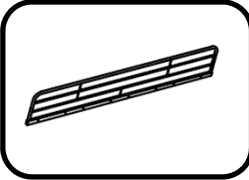

#3 x 2 pcs
Side Guardrail

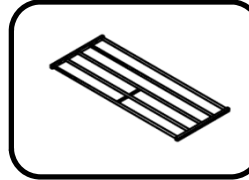

#4 x 4 pcs
Outer Support Frame

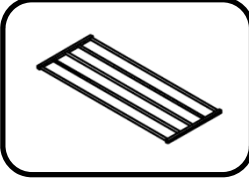

#5 x 4 pcs
Inner Support Frame

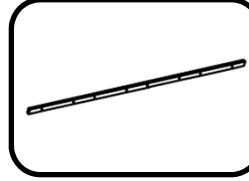

#6 x 2 pcs
Side Rail

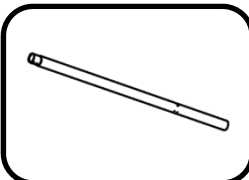

#7 x 2 pcs
Corner Post A

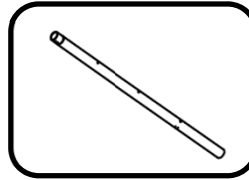

#8 x 2 pcs
Corner Post B

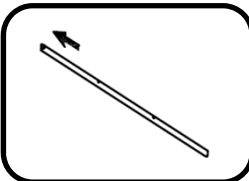

#9 x 2 pcs
Ladder Side

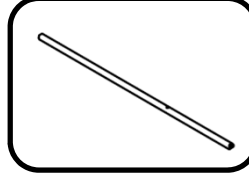

#10 x 2 pcs
End Rail

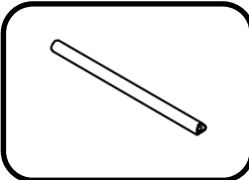

#11 x 4 pcs
Ladder Rung



Due to the size and/or weight of this product, it is highly recommended that the assembly should be done near the area of its intended location. Make sure you have enough space to move around during the assembly. ALWAYS have at least two people to help with transporting and assembling the product to avoid any potential injury and/or damage.

Hardware List



#A x 36 pcs
Bolt 1/4"x5/8"



#B x 12 pcs
Bolt 1/4"x1-3/8"



#C x 20 pcs
Bolt 1/4"x3"



#D x 8 pcs
Bracket



#E x 36 pcs
Flat Washer



#F x 1 pc
Allen Wrench



#G x 4 pcs
Curved Washer



#H x 24 pcs
Lock Washer

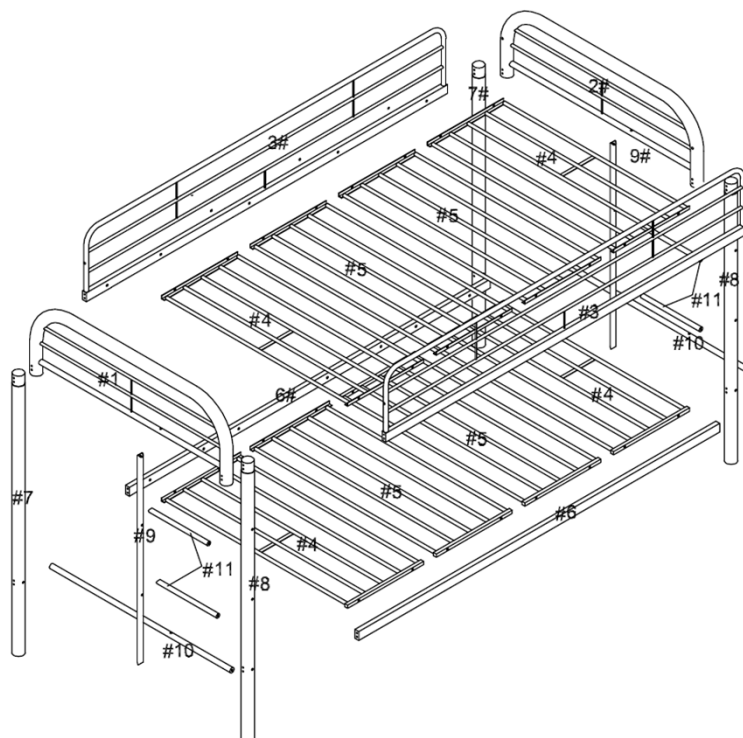

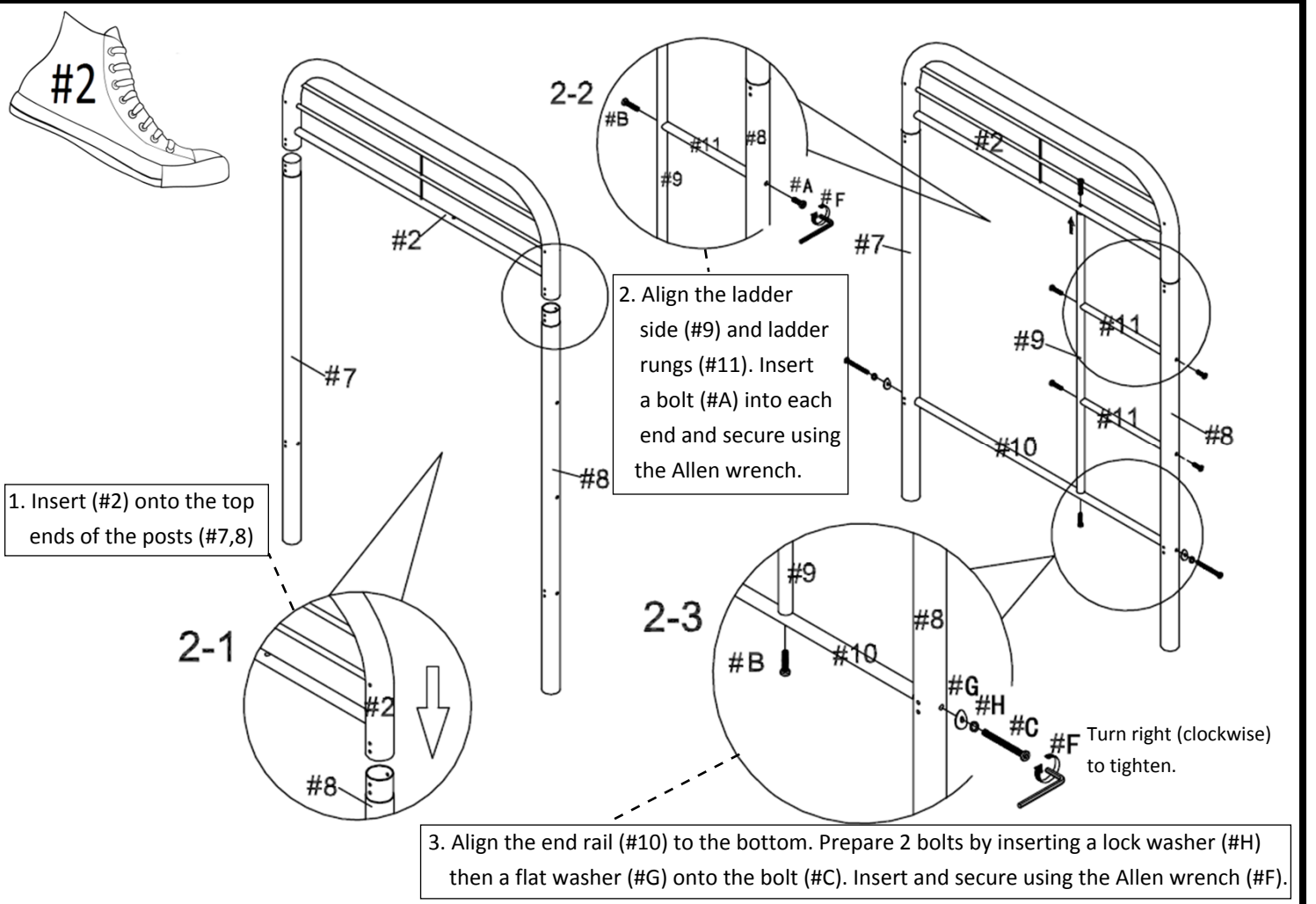
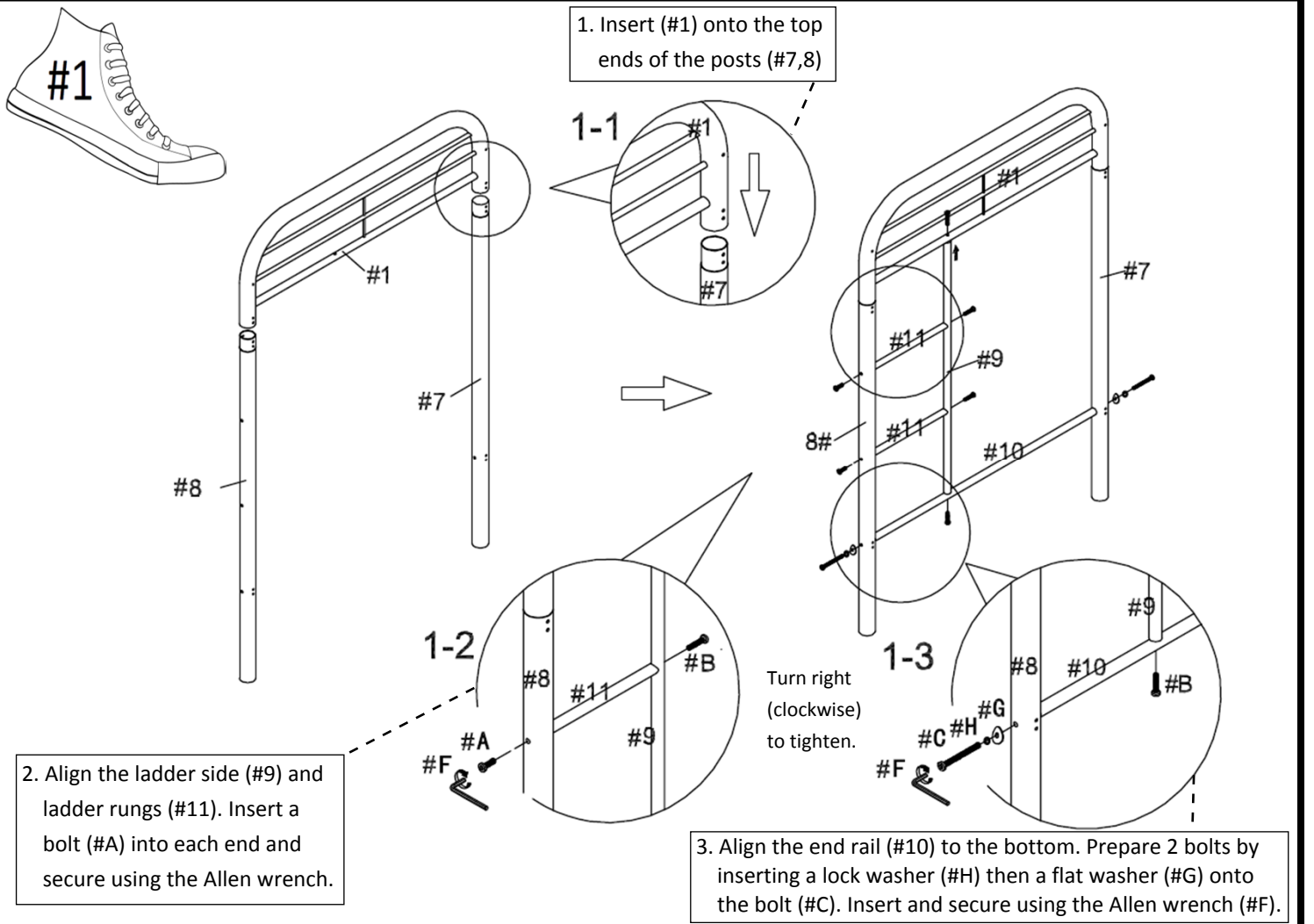



2. Align the guardrail (#3) to the top. Insert a lock washer (#H) onto the bolts (#C). Then align the brackets (#D) to the outer post and insert those prepared bolts. Insert a lock washer (#H) onto the bolts (#B). Insert those into the inner holes.

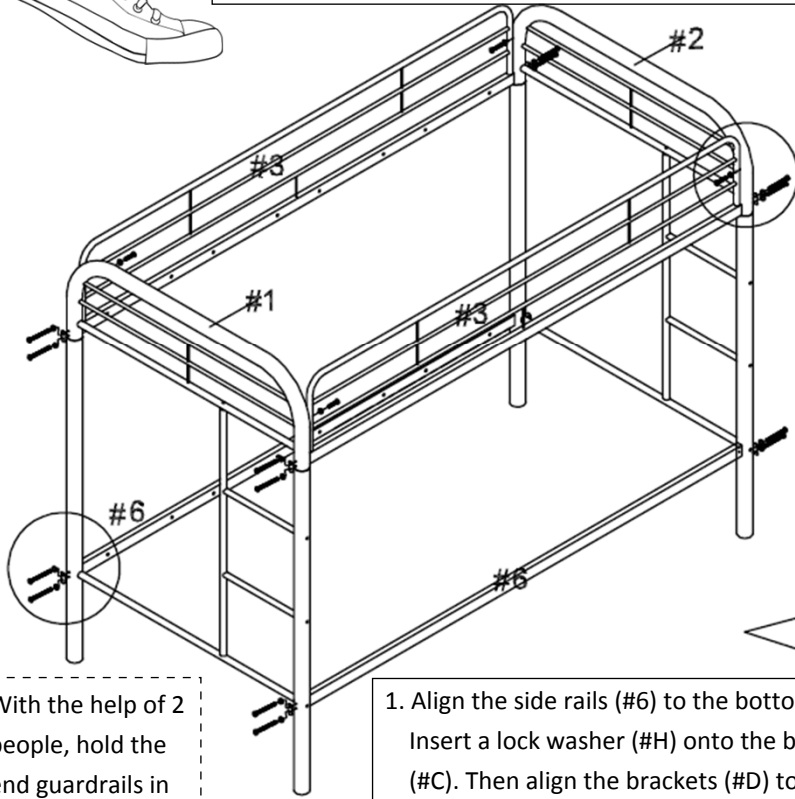

Turn right (clockwise) to tighten

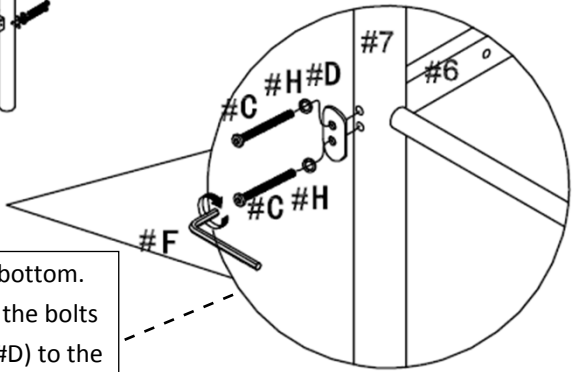

With the help of 2 people, hold the end guardrails in place while aligning the rails.

1. Align the side rails (#6) to the bottom. Insert a lock washer (#H) onto the bolts (#C). Then align the brackets (#D) to the post and insert those prepared bolts. Secure using the Allen wrench (#F).



2. Insert a flat washer (#E) onto the bolts (#A) and insert into the inner holes. Secure using the Allen wrench.

1. Place the support frames (#4,5) in the positions displayed.

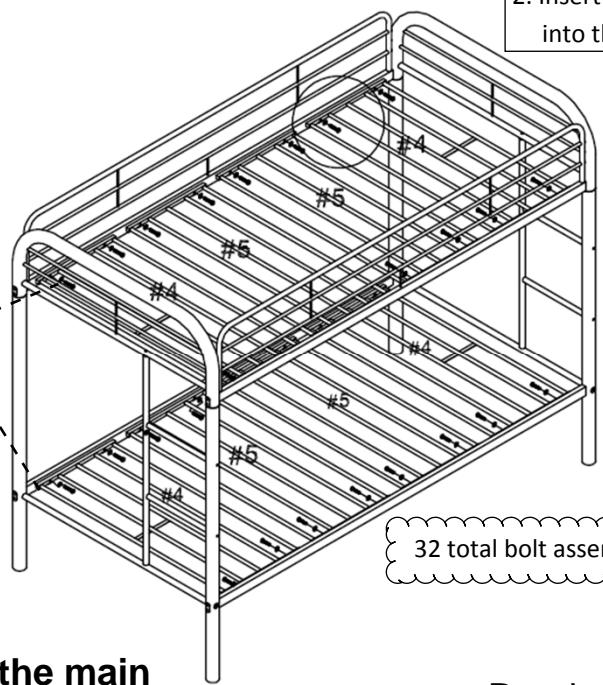

32 total bolt assemblies.

Turn right (clockwise) to tighten

Safety is ALWAYS the main priority. Please take the time to inspect the assembly and FULLY tighten all bolts/screws from Step 1 to Step 4.

Read and follow the information on the WARNINGS shown on the end structure of the upper bunk and on the carton. Do not remove warning label from the bed. Keep these instructions for future reference.

ASSEMBLY IS COMPLETED

Safety Warnings for Bunk Beds

1. Read and follow the information on the WARNINGS shown on the end structure of the upper bunk and on the carton. Do not remove warning label from the bed. Keep these instructions for future reference.
2. Always use the recommended size mattress or mattress support, or both, to help prevent the likelihood of entrapment or falls. The proper mattress sizes for the **UPPER TWIN-SIZE bunk** should be 74" to 75" long x 37½" to 38½" wide x 6" high (no higher than 6") and for the **LOWER TWIN-SIZE bunk** should be 74" to 75" long x 37½" to 38½" wide x 6" to 8" high.
3. Surface of mattress must be at least 5 inches (127 mm) **BELOW** the upper edge of guardrails.
4. Do not allow persons under 6 years of age to use the upper bunk.
5. Periodically check and ensure that the guardrails, ladder, handle and other components are in their proper position, free from damage, and that all connectors are tighten and secured.
6. For safety reasons, especially on the upper bunk bed, **DO NOT** allow rough playing or jumping on the bed and do not allow playing or hiding under the bed.
7. Always use the ladder for entering and leaving the upper bunk.
8. Do not use substitute parts. Contact the manufacturer or dealer for replacement parts.
9. Use of a nightlight may provide added safety precaution for a person using the upper bunk.
10. Always use the guardrails on both long sides of the upper bunk. If the bunk bed will be placed next to the wall, the guardrail that runs the full length of the bed should be placed against the wall to prevent entrapment between the bed and the wall.
11. The use of water or sleep flotation mattresses is prohibited.
12. No more than one person is allowed on the upper bunk at all times.
13. The **MAXIMUM** weight capacity for the upper bunk is not to exceed 150 lbs.



WARNING: STRANGULATION HAZARD

Never attach or hang objects to any part of the bunk bed that are not designed for use with the bed. Objects such as hanger, hook, belt, bag, rope, string, etc. should not be used on or around the bunk bed.