



*ASSEMBLY INSTRUCTIONS
COASTER FINE FURNITURE*



Fine Furniture for every stage of life

108891(B1&B2)
Dining Table

ITEM : 108891(B1&B2)



ASSEMBLY INSTRUCTIONS

ASSEMBLY TIPS:

1. Remove hardware from box and sort by size.
2. Please check to see that all hardware and parts are present prior to start of assembly.
3. Please follow attached instructions in the same sequence as numbered to assure fast & easy assembly.



WARNING!

1. Don't attempt to repair or modify parts that are broken or defective. Please contact the store immediately.
2. This product is for home use only and not intended for commercial establishments.



ASSEMBLY TIME

10 MINUTES

PARTS IDENTIFICATION

B1 (BOX 1)

A TOP

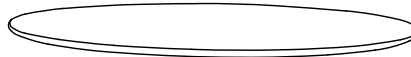

1PC

B2 (BOX 2)

B LEG FRAME

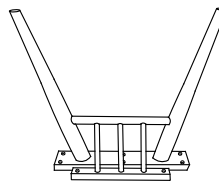

2PCS

C LEG SUPPORT

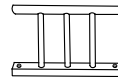

2PCS

HARDWARE IDENTIFICATION

Z-B1 (BOX 1) - HARDWARE PACK IS LOCATED IN 108891 (B1)

1 BOLT WITH WASHER
(M6 x 40mm - BLK, M6 x 18mm - BLK)

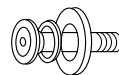

20PCS

2 PAN HEAD SCREW
(M5 x 38mm - BLK)



8PCS

3 ALLEN WRENCH
(M4 x 60mm - GD)



1PC

NOTE:

Phillips head screw driver is required in the assembly process; however, manufacturer does not provide this item.

ITEM : 108891(B1&B2)

ASSEMBLY INSTRUCTIONS



STEP 1

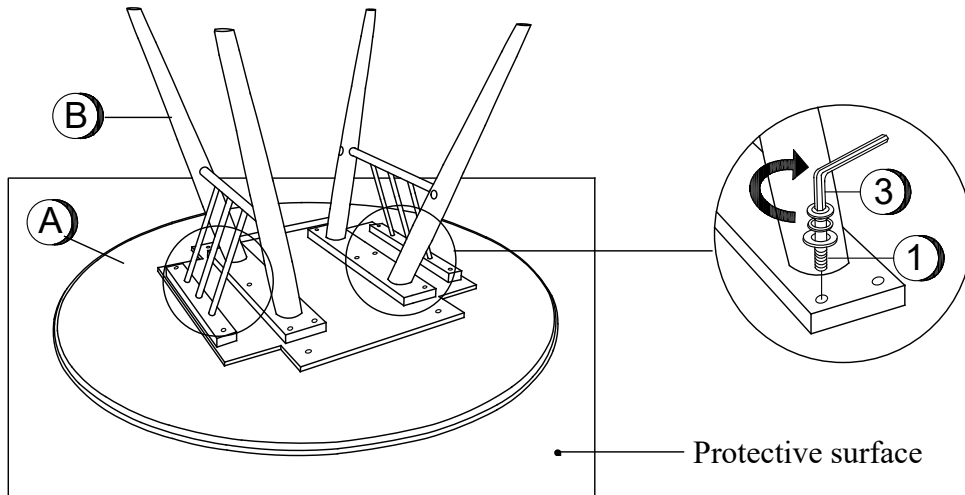

STEP 2

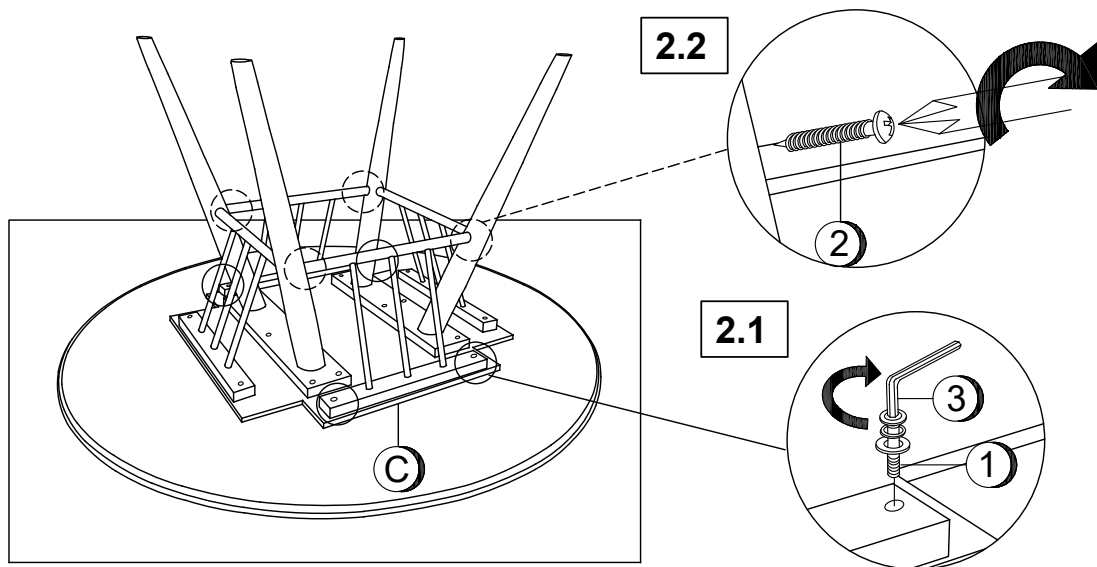

STEP 3 COMPLETE

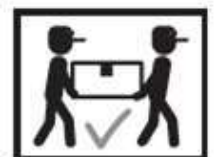
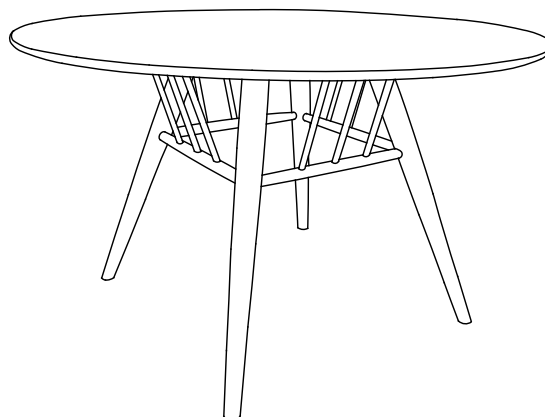

ITEM : 108891(B1&B2)

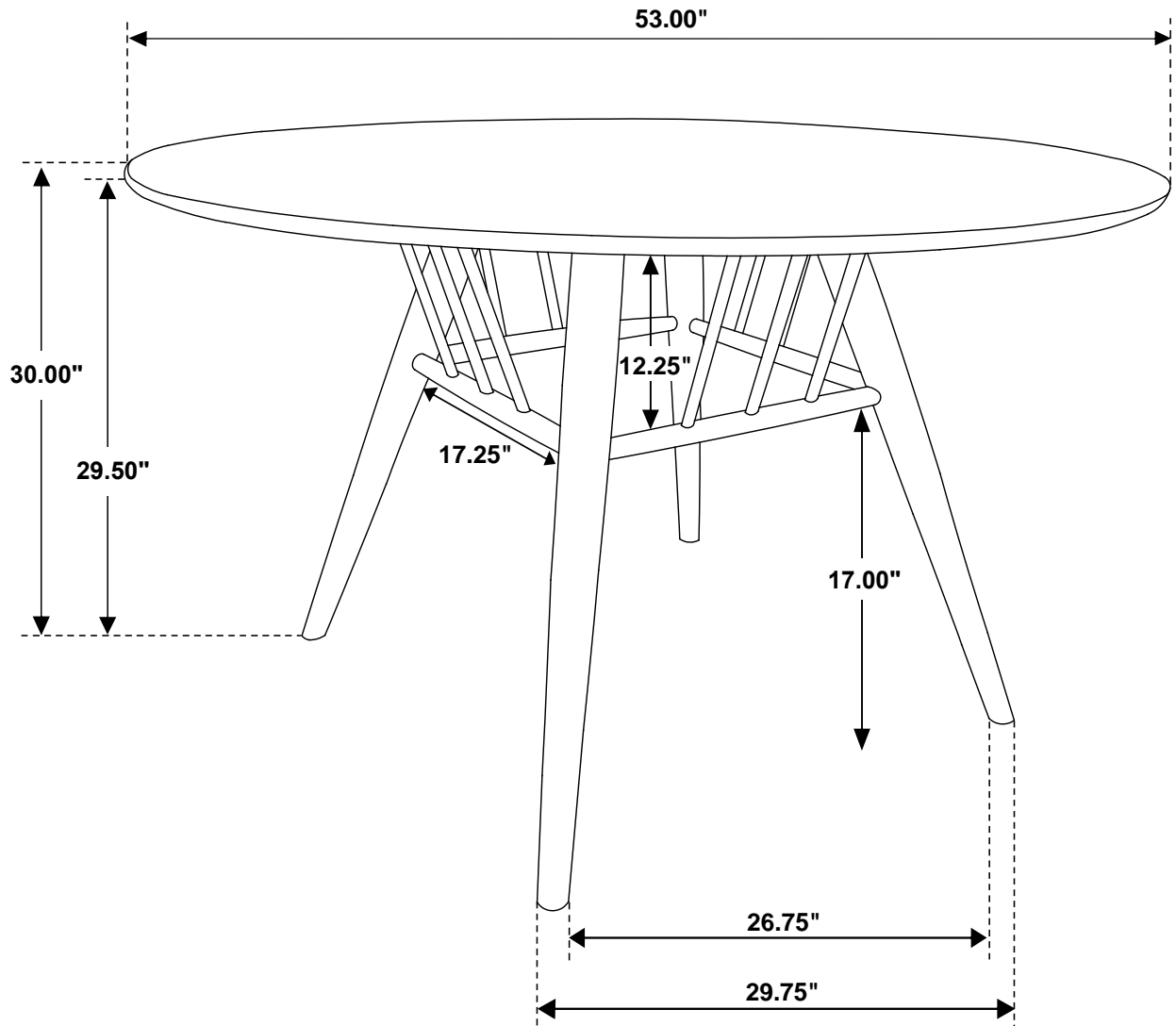

Note : Dimension tolerance $\pm 5\%$