

ASSEMBLY INSTRUCTIONS

INSTRUCTIONS DE MONTAGE

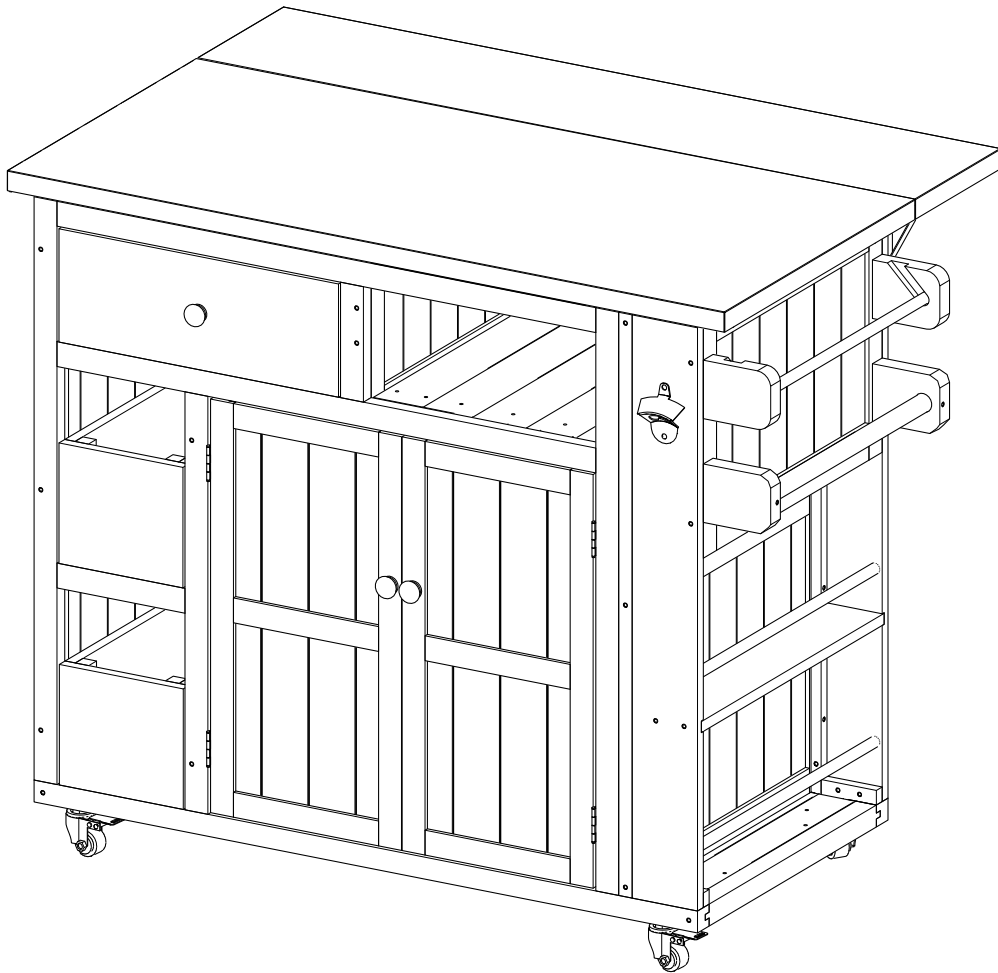

IMPORTANT NOTE:

- ① PLACE ALL PARTS ON A CLEAN AND SMOOTH SURFACE SUCH AS A RUG OR CARPET TO AVOID THE PARTS FROM BEING SCRATCHED.
- ② BEFORE YOU BEGIN, KINDLY FOLLOW THE ASSEMBLY INSTRUCTIONS STEP BY STEP.
- ③ DO NOT TIGHTEN ALL SCREWS AND BOLTS UNTIL THIS ITEM IS FULLY SET-UP.

NOTE IMPORTANTE:



- ① PLACEZ TOUTES LES PIÈCES SUR UNE SURFACE PROPRE ET LISSE TELLE QU'UN TAPIS OU UN TAPIS POUR ÉVITER LES PIÈCES D'ÊTRE RAYÉES.
- ② AVANT DE COMMENCER, VEUILLEZ SUIVRE LES INSTRUCTIONS D'ASSEMBLAGE ÉTAPE PAR ÉTAPE.
- ③ NE SERREZ PAS TOUTES LES VIS ET LES BOULONS TANT QUE CET ARTICLE N'EST PAS ENTIÈREMENT INSTALLÉ.



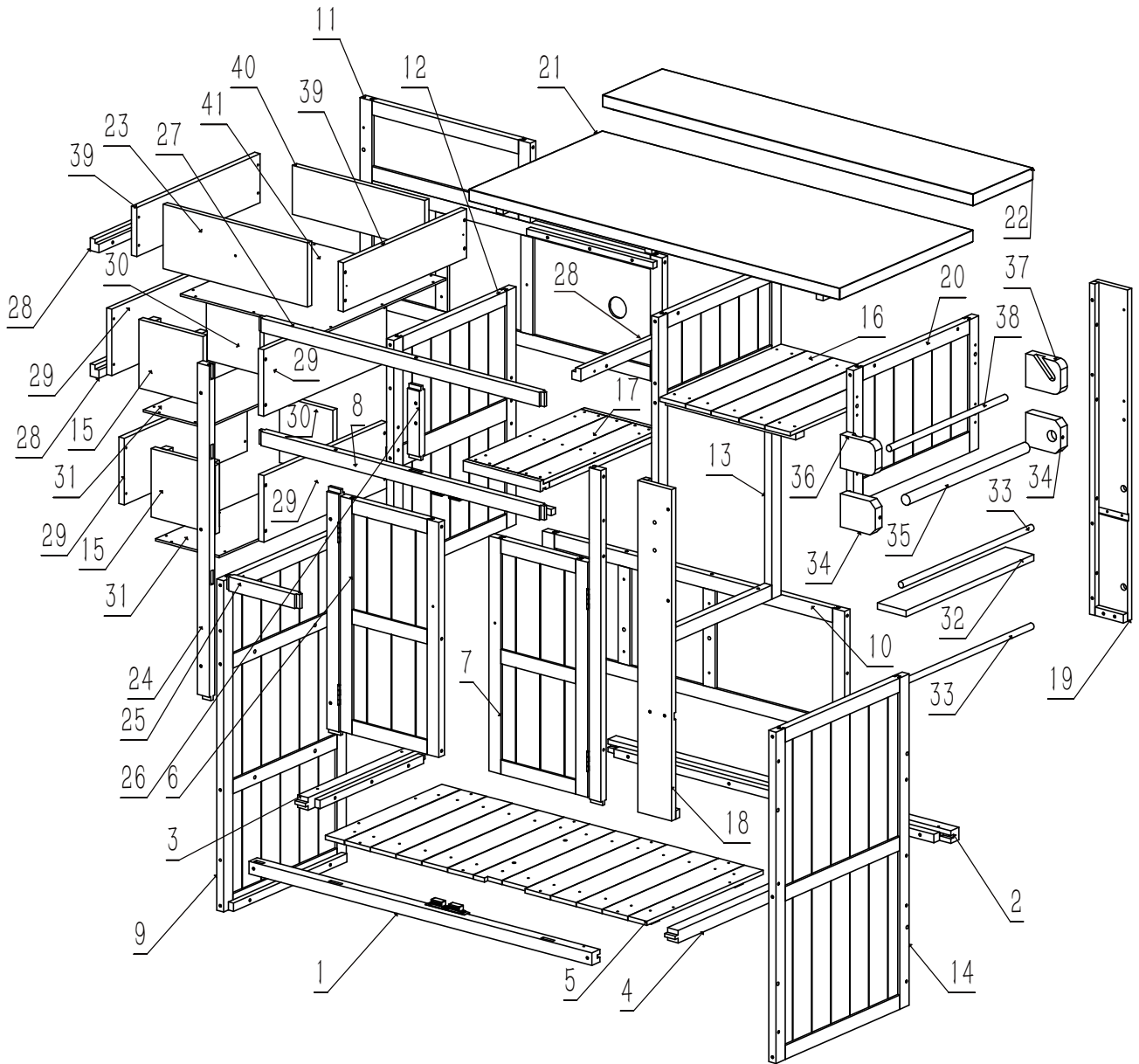



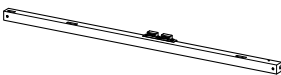
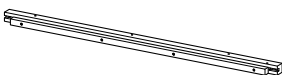
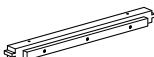
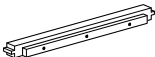
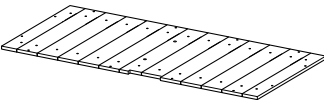
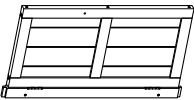
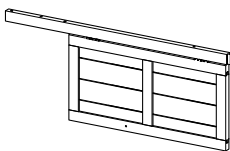
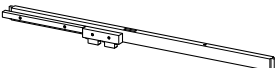
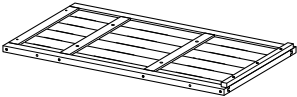
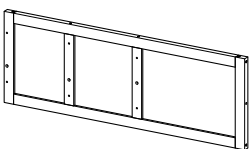
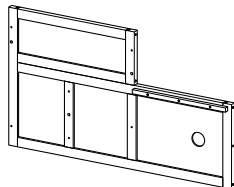
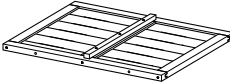
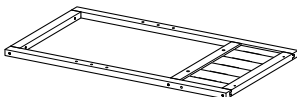
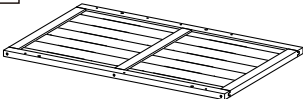
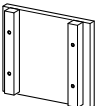
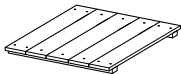
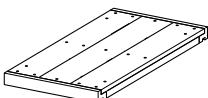
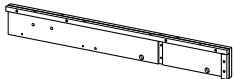
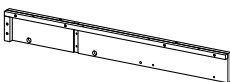
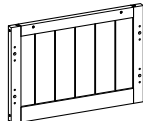
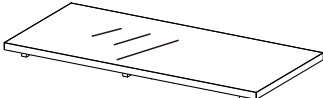
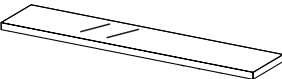
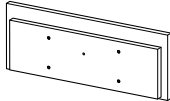



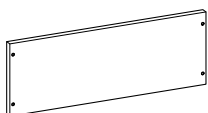
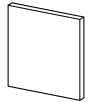
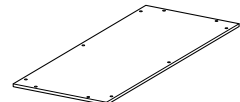

Detail View

Vue détaillée





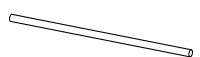

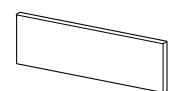
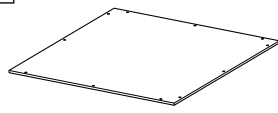

Part List
Liste des pièces



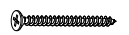















1	2	3	4
			
Front crossbar of bottom panel Barre transversale avant du panneau inférieur 1pc	Back crossbar of bottom panel Barre transversale arrière du panneau inférieur 1pc	Left vertical partition of bottom panel Cloison verticale gauche du panneau inférieur 1pc	Right vertical partition of bottom panel Cloison verticale droite du panneau inférieur 1pc
5	6	7	8
			
Bottom panel Panneau inférieur 1pc	Left door Porte gauche 1pc	Right door Porte droite 1pc	Middle crossbar of front panel Barre transversale centrale du panneau avant 1pc
9	10	11	12
			
Left side panel Panneau latéral gauche 1pc	Lower back panel Panneau inférieur du dos 1pc	Upper back panel Panneau arrière supérieur 1pc	Left middle side panel Panneau latéral gauche central 1pc
13	14	15	16
			
Middle side panel Panneau latéral central 1pc	Right middle side panel Panneau latéral droit central 1pc	Front panel of small drawer Panneau avant d'un petit tiroir 2pcs	Upper bottom panel Panneau inférieur supérieur 1pc
17	18	19	20
			
Shelf Étagère 1pc	Side panel of storage rack 1 Panneau latéral d'étagère de rangement 1pc	Side panel of storage rack 2 Panneau latéral d'étagère de rangement 2 1pc	Right side panel Panneau latéral 1pc
21	22	23	24
			
Table top 1 Dessus de table 1 1pc	Table top 2 Dessus de table 2 1pc	Front panel of drawer Panneau avant du tiroir 1pc	Left vertical partition of front panel Cloison verticale gauche du panneau avant 1pc

25		26		27		28	
	Lower middle crossbar of front panel. Barre transversale inférieure centrale du panneau avant 1pc		Upper middle vertical partition of front panel. Partition verticale supérieure centrale du panneau avant 1pc		Upper crossbar of front panel Slat supérieur du panneau avant 1pc		Drawer support strip Bande de support pour tiroir 3pcs
29		30		31		32	
	Side panel of small drawer Panneau latéral d'un petit tiroir 4pcs		Back panel of small drawer Panneau arrière d'un petit tiroir 2pcs		Bottom panel of small drawer Panneau inférieur d'un petit tiroir 2pcs		Right shelf panel Panneau droit de l'étagère 1pc
33		34		35		36	
	Round rod 1 Barre ronde 1 2pcs		Handle fixing block 1 Bloc de fixation de poignée 1 2pcs		Round rod 3 Barre ronde 3 1pc		Handle fixing block 2 Bloc de fixation de poignée 2 1pc
37		38		39		40	
	Handle fixing block 3 Bloc de fixation de poignée 3 1pc		Round rod 2 Barre ronde 2 1pc		Side panel of drawer Panneau latéral du tiroir 2pcs		Back panel of drawer Panneau arrière du tiroir 1pc
41							
	Bottom panel of drawer Panneau inférieur du tiroir 1pc						

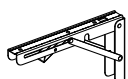
Hardware List
Liste du matériel

A		B		C		D	
	3.5*60 Ph zinc screws Vis de zinc ph 9+1pcs		3.5*50 Ph zinc screws Vis de zinc ph 14+1pcs		3.5*45 Ph zinc screws Vis de zinc ph 10+1pcs		3.5*40 Ph zinc screws Vis de zinc ph 36+1pcs
E		F		G		H	
	3.5*35 Ph zinc screws Vis de zinc ph 6+1pcs		3.5*16 Ph zinc screws Vis de zinc ph 6+1pcs		3*30 Ph zinc screws Vis de zinc ph 36+1pcs		3*25 Ph zinc screws Vis de zinc ph 12+1pcs

Hardware List
Liste du matériel

<p>I</p>  <p>3*20 Ph zinc screws Vis de zinc ph 34+1pcs</p>	<p>J</p>  <p>M6*25 Ph zinc bolt Boulon de zinc ph 2+1pcs</p>	<p>K</p>  <p>M4*35 Ph zinc bolt Boulon de zinc ph 1+1pcs</p>	<p>L</p>  <p>M4*25 Ph zinc bolt Boulon de zinc ph 2+1pcs</p>
<p>M</p>  <p>4*18 Ph zinc screws Vis de zinc ph 10+1pcs</p>	<p>N</p>  <p>Dowel Goujon 33+2pcs</p>	<p>O</p>  <p>Pull box Boîte à tirer 1pc</p>	<p>P</p>  <p>Bottle opener Ouvre-bouteille-1pc</p>
<p>Q</p>  <p>Door knob Bouton de porte 3pcs</p>	<p>R</p>  <p>Fixed wheel Roue fixe 2pcs</p>	<p>S</p>  <p>Brake wheel Roue de frein 2pcs</p>	<p>T</p>  <p>5 cm drawer stopper Butée de tiroir de 5 cm 2pcs</p>
<p>U</p>  <p>Movable pole support Support de poteau mobile 2pcs</p>	<p>V</p>  <p>Laminated nail Clou laminé 4pcs</p>	<p>W</p>  <p>Ground nail Clou de sol 2pcs</p>	<p>X</p>  <p>Angle steel Cornière en acier 2pcs</p>
 <p>L shape wrench Clé en L 1pc</p>	 <p>Open-end Wrench Clé à fourche 1pc</p>		

**ASSEMBLY TOOLS REQUIRED(NOTINCLUDED)
OUTILS D'ASSEMBLAGE REQUIS (NON INCLUS)**

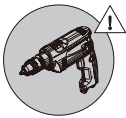

**PLEASE BE CAREFUL DO NOT DAMAGE THE HOLE POSITION
WHEN YOU USE POWERTOOLS!**

**VEUILLEZ FAIRE ATTENTION À NE PAS ENDOMMAGER LA POSITION
DU TROU LORS DE L'UTILISATION D'OUTILS ÉLECTRIQUES!**

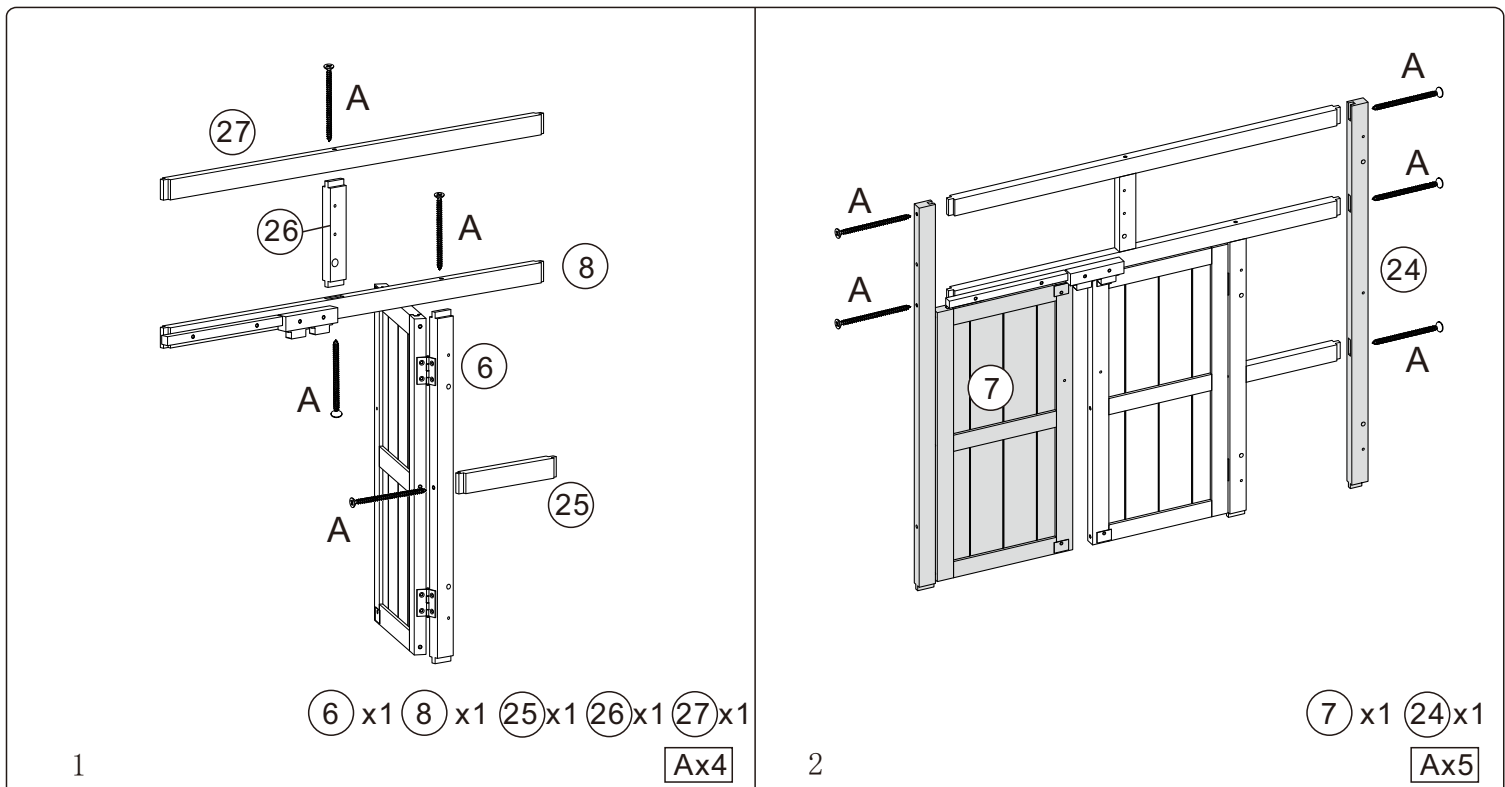

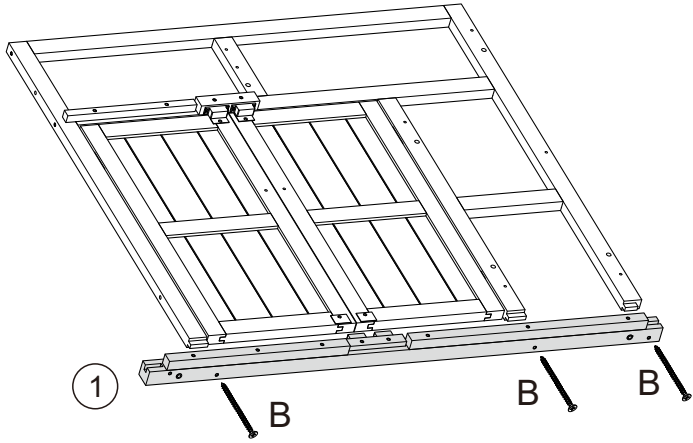

1

B

B

B

1 x1
Bx3

3

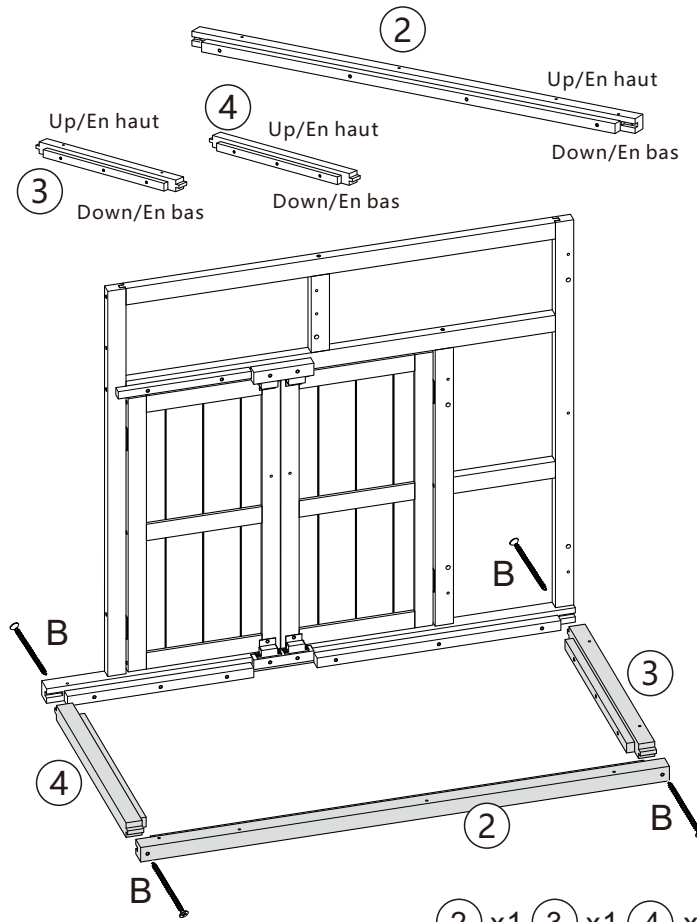

2

Up/En haut

Up/En haut

4

Up/En haut

Down/En bas

3

Down/En bas

Down/En bas

B

3

4

2

B

2 x1 3 x1 4 x1
Bx4

4

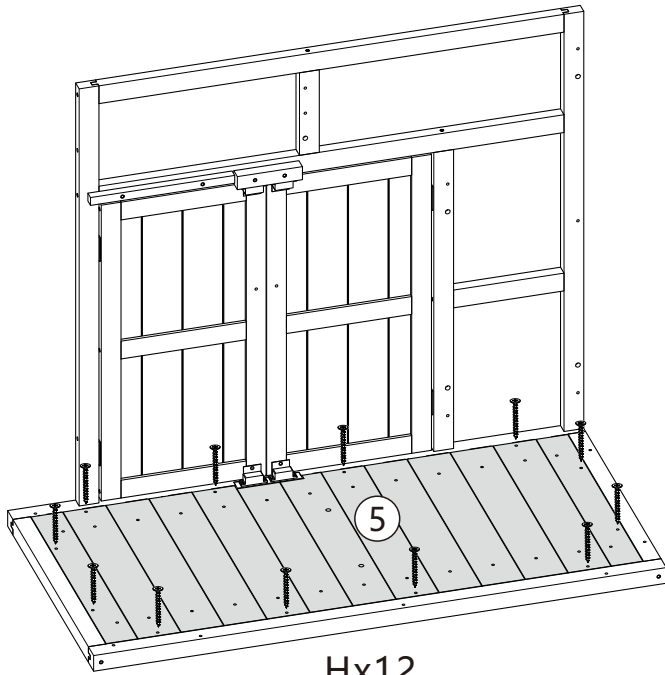

5

Hx12

5 x1
Hx12

5

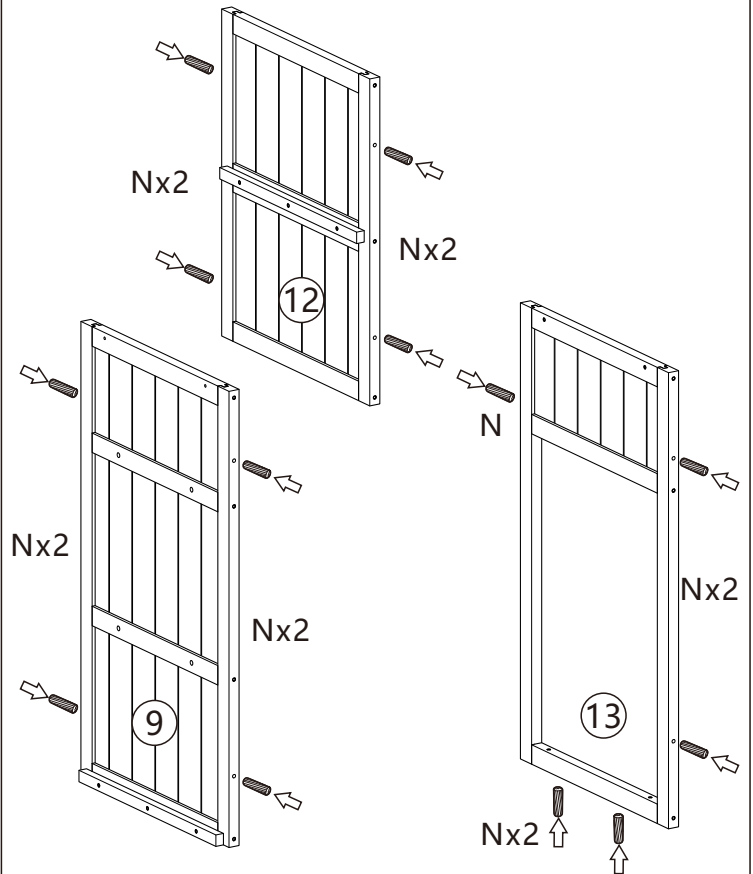

Nx2

Nx2

12

Nx2

Nx2

9

Nx2

N

Nx2

13

9 x1 12 x1 13 x1
Nx13

6

6

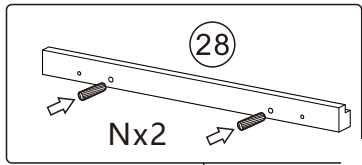

x3

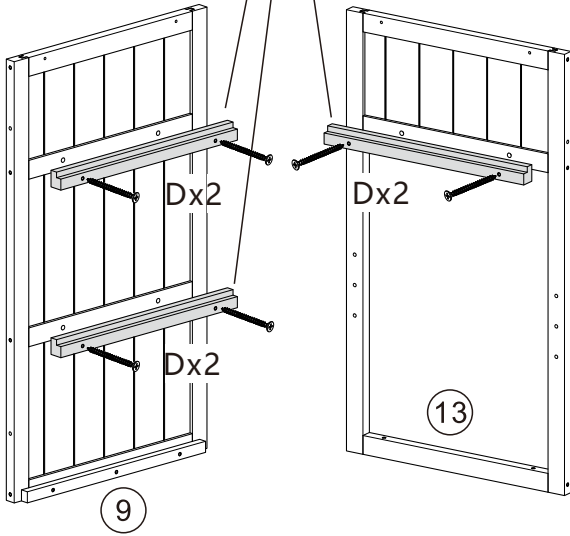

7

(28)x3
Dx6 Nx6

Up/En haut

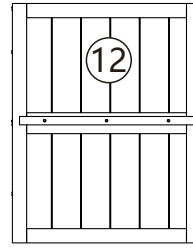

Down/En bas

Pay attention to the position of the support strip.
Faites attention à la position de la bande de support.

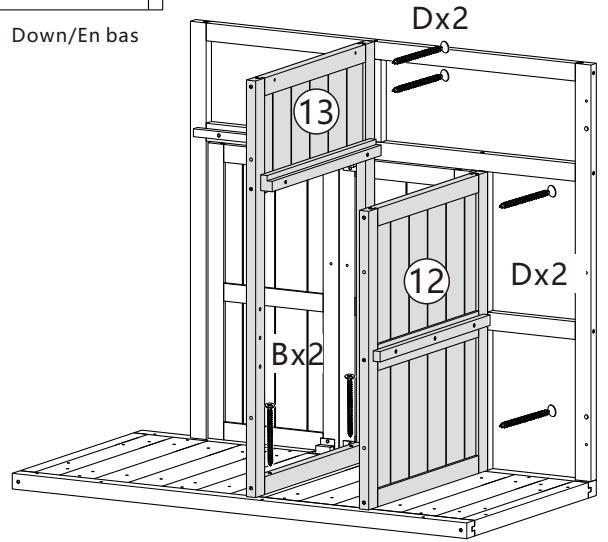

8

Bx2 Dx4

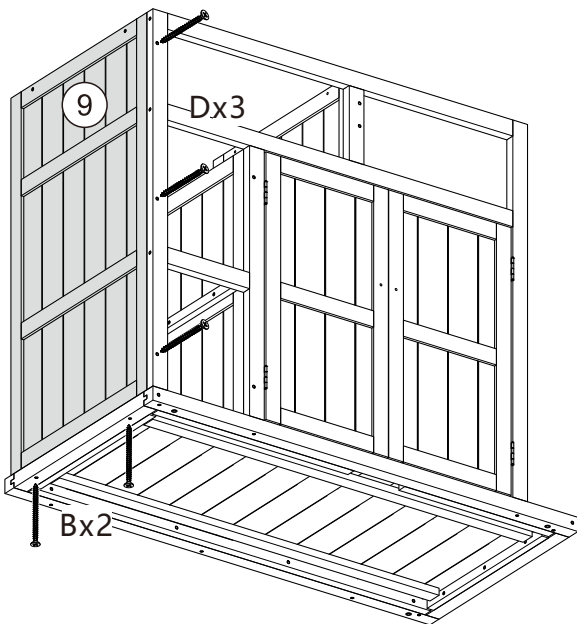

9

Bx2 Dx3

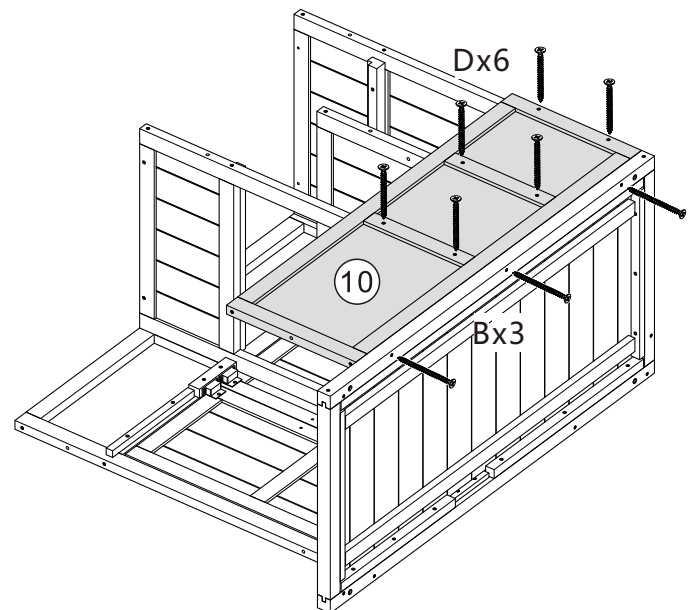

10

(10)x1
Bx3 Dx6

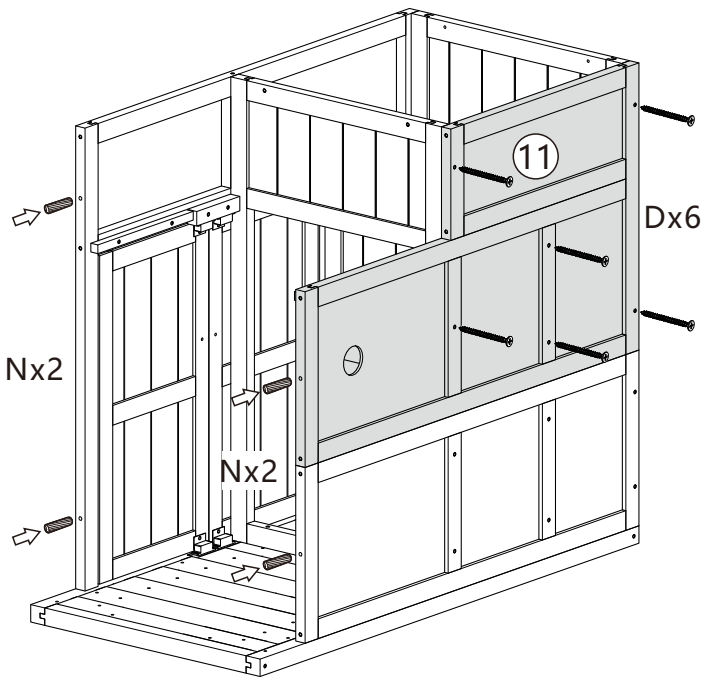

11

①①x1
Dx6 Nx4

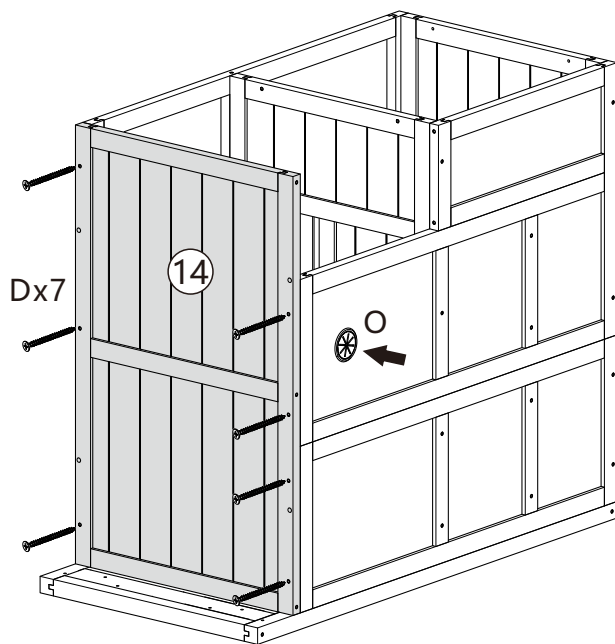

12

①④x1
Dx7 Ox1

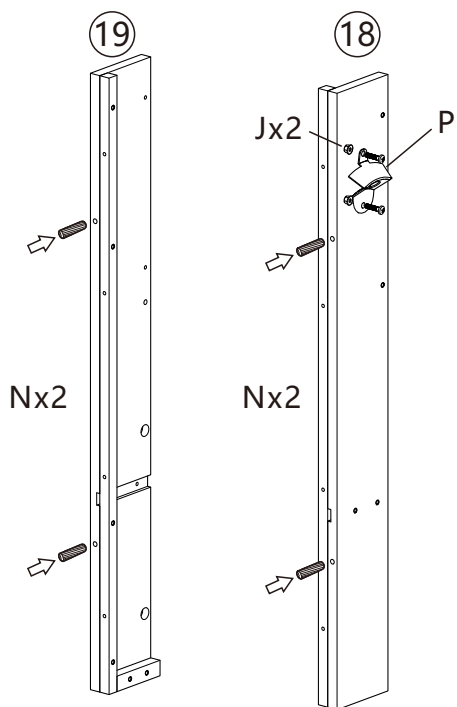

13

①⑧x1 ①⑨x1
Jx2 Nx4 Px1

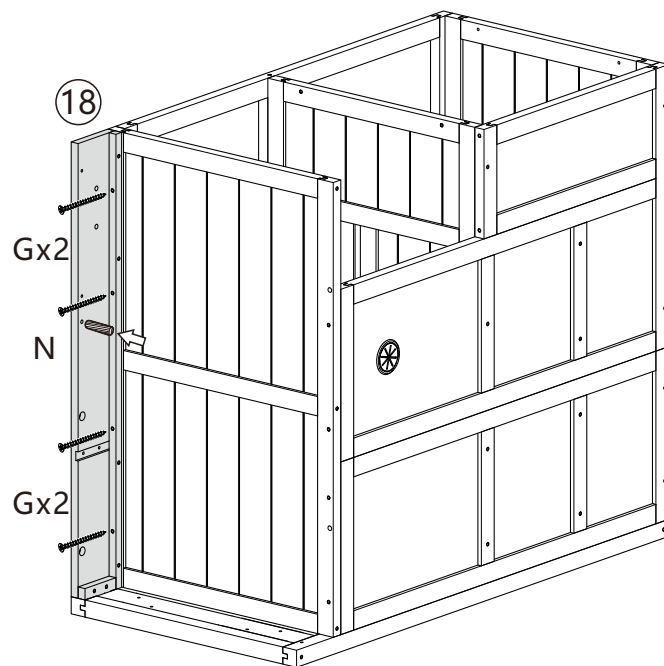

14

Gx4 Nx1

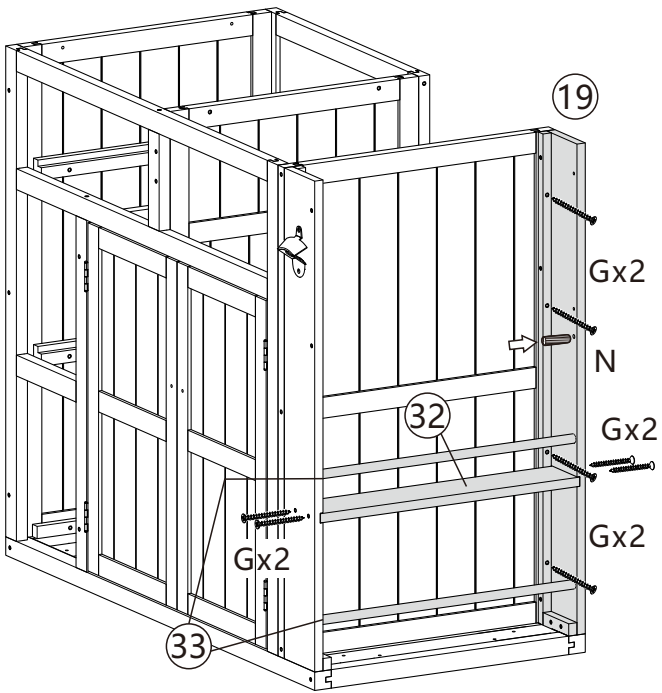

15

32)x1 33)x2
Gx8 Nx1

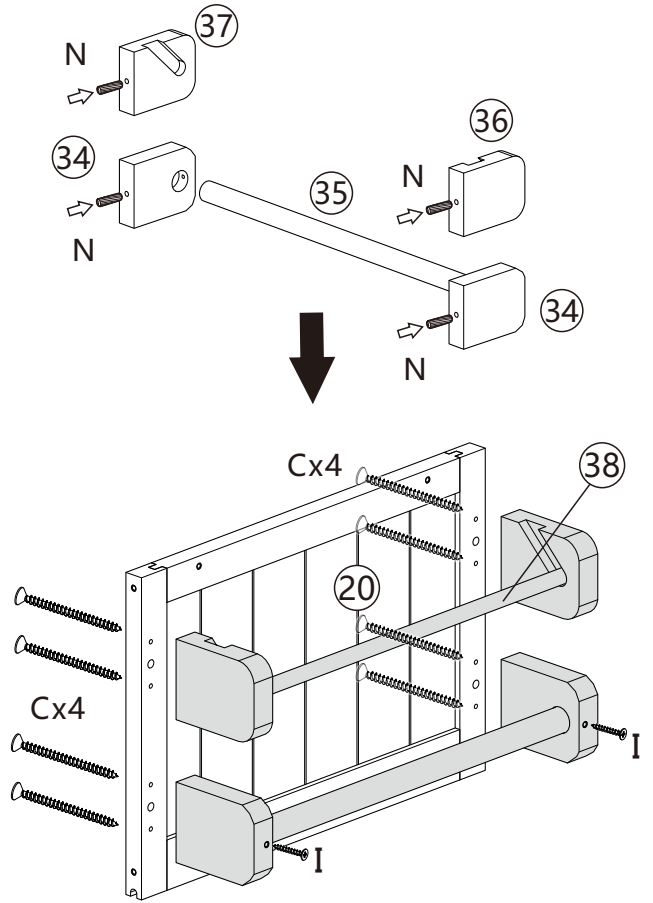

16

20)x1 34)x2 35)x1 36)x1 37)x1 38)x1
Cx8 Nx4 Ix2

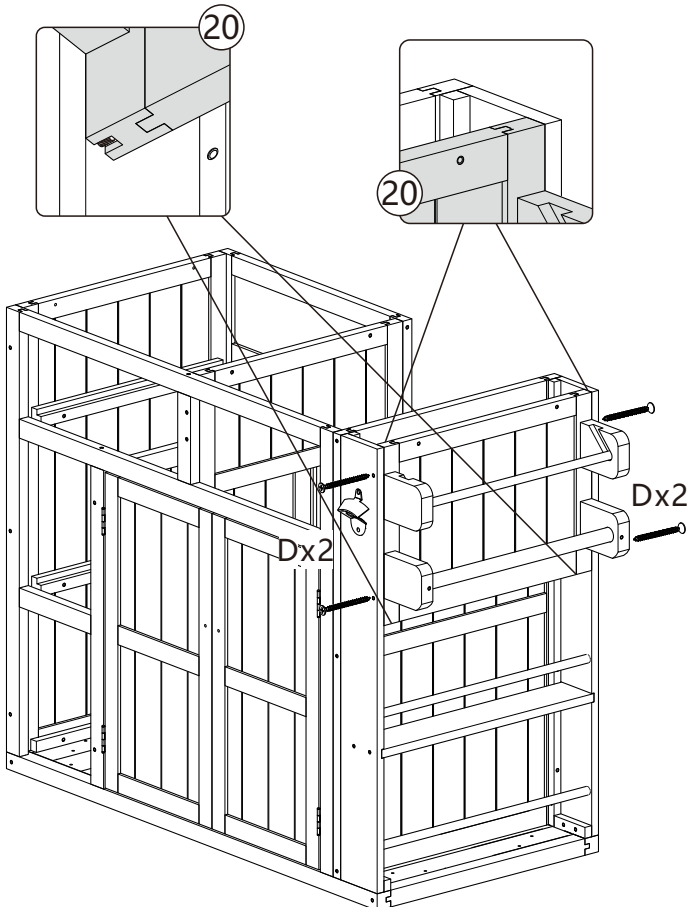

17

Dx4

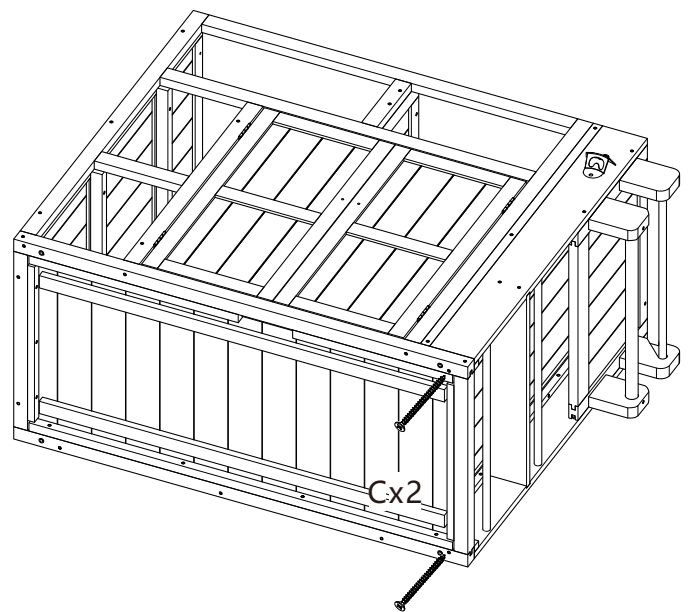

18

Cx2

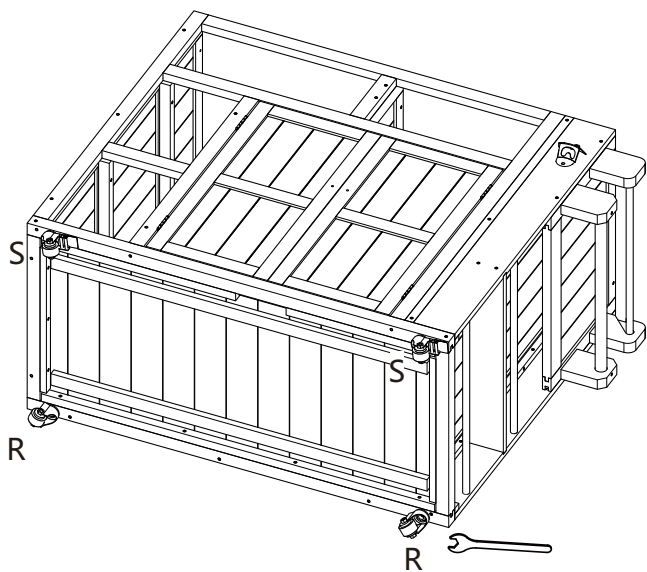

19

Rx2 Sx2

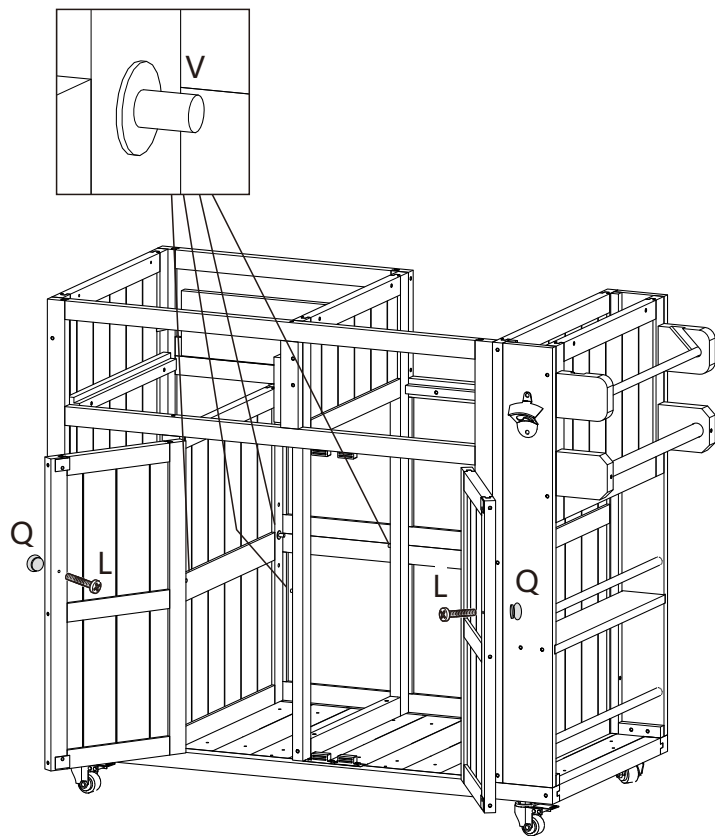

20

Lx2 Qx2 Vx4

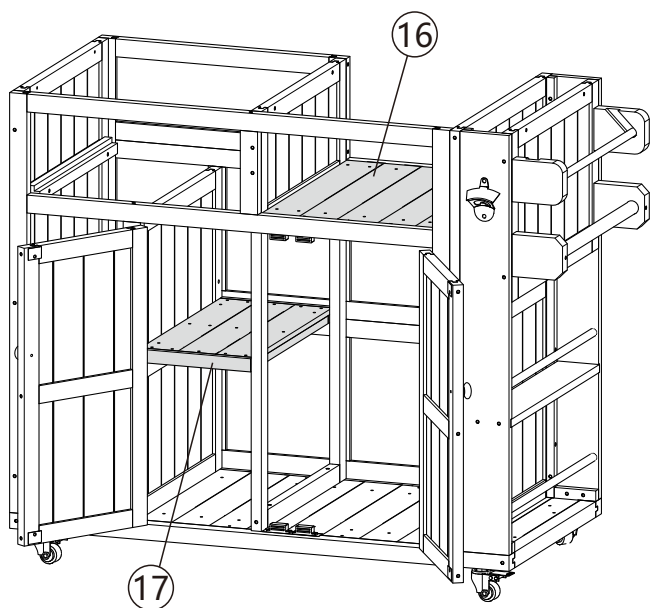

21

16x1 17x1

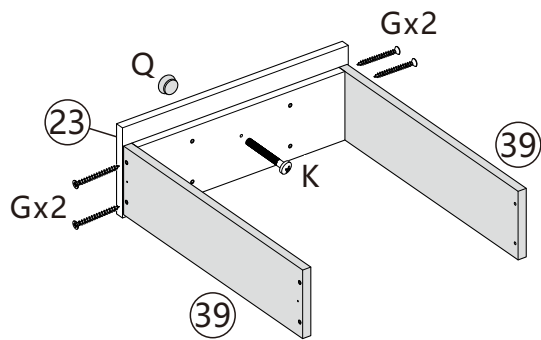

22

15x2 23x1 29x4 39x2
Gx12 Kx1 Qx1

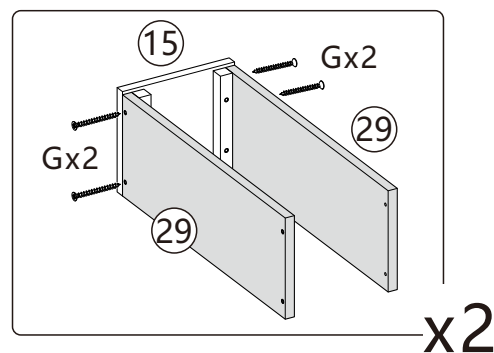

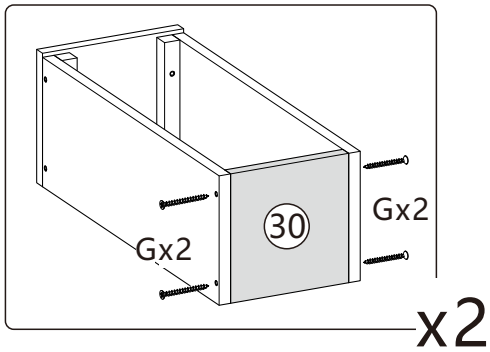
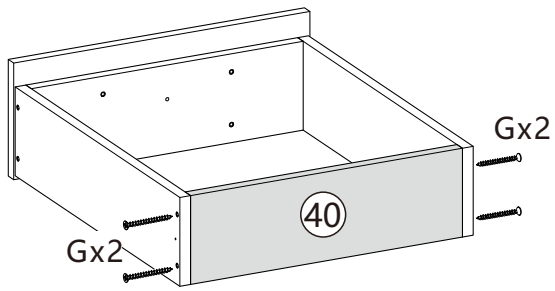

30x2 40x1
Gx12

23

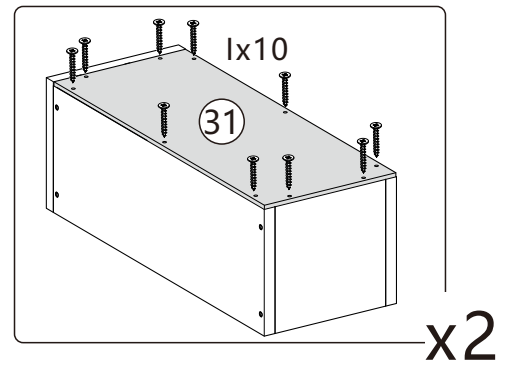
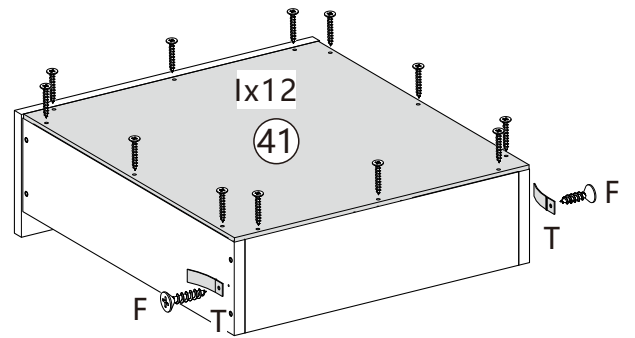

31x2 41x1
Fx2 Ix32 Tx2

24

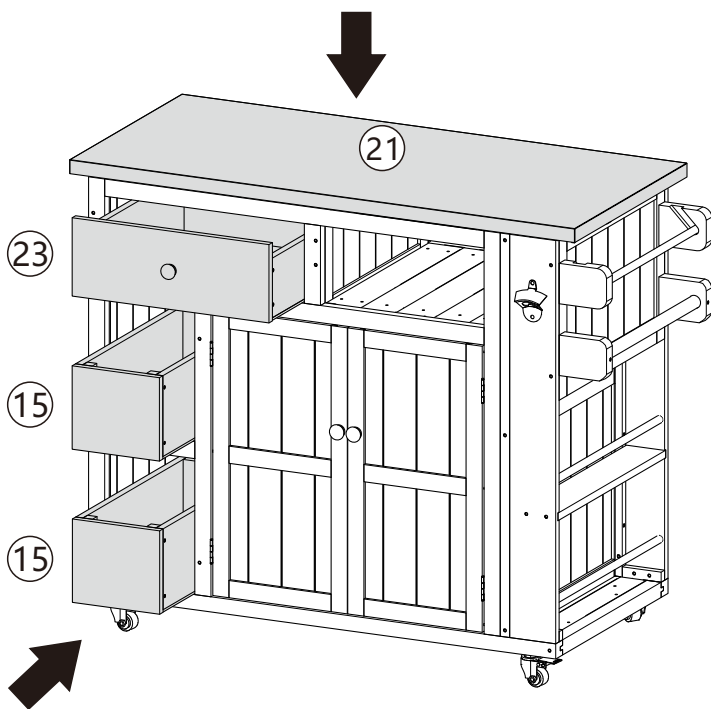

25

21x1

Make sure Part 21&22 are flush with Part 11
Assurez-vous que les parties 21 et 22 sont alignées avec la partie 11

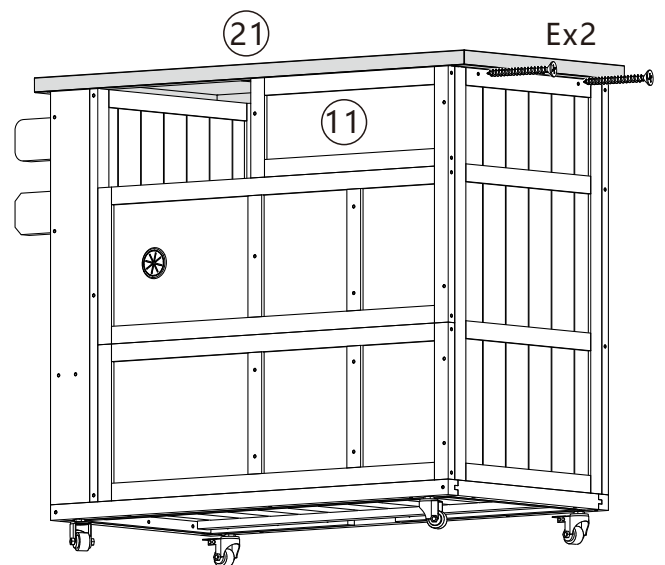
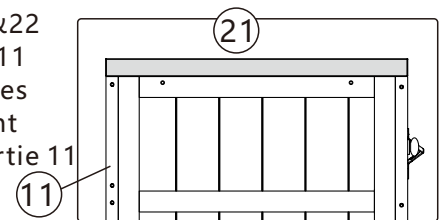

26

Ex2

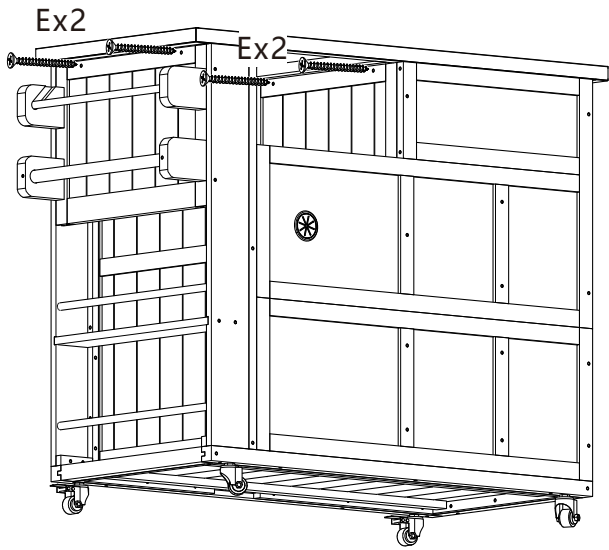

27

Ex4

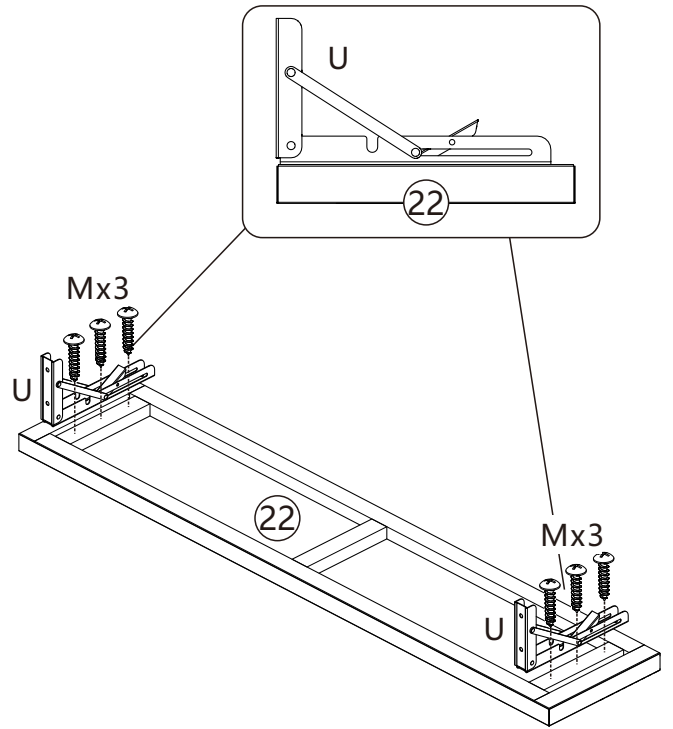

28

(22)x1
Mx6 Ux2

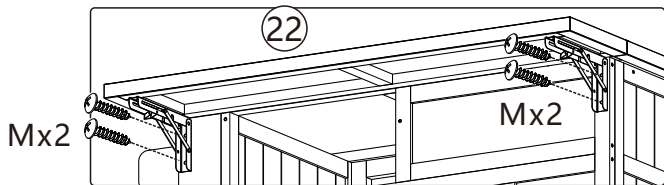

Mx2

Mx2

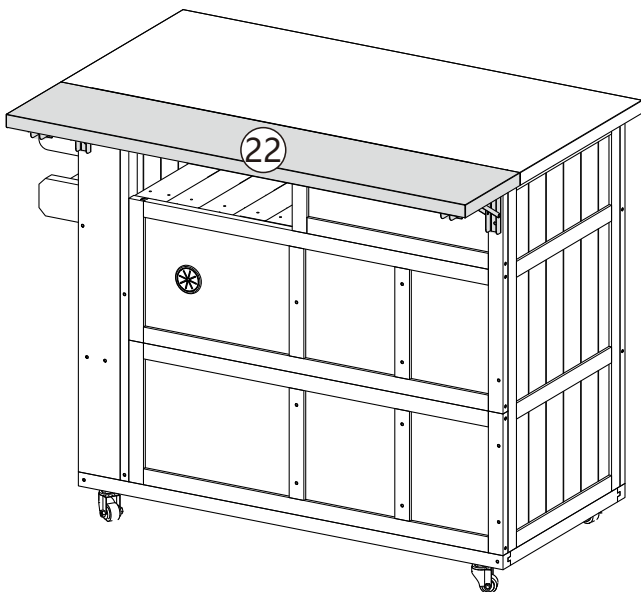

29

Mx4

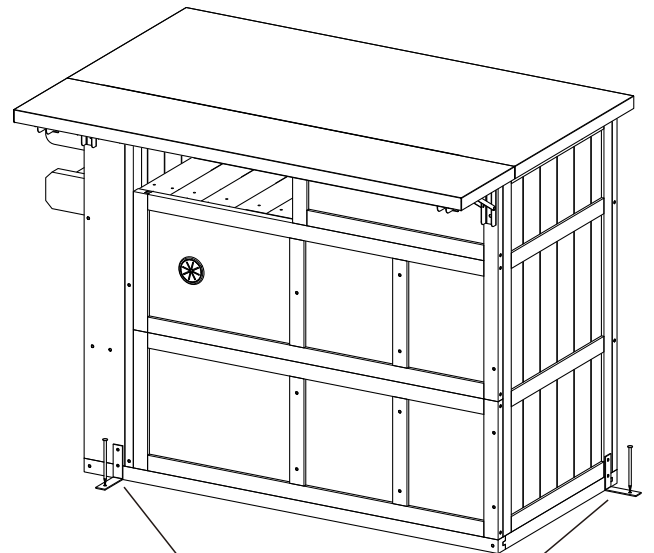

Remove 4 wheels firstly, then assembly L shape metal and nails.
Retirez 4 roues tout d'abord, puis assemblage en forme de L métal et clous.

30

Fx4 Wx2 Xx2