

**Storage Unit
8 Shelf 36in H**

Model #: SPG-13887

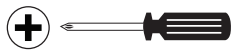
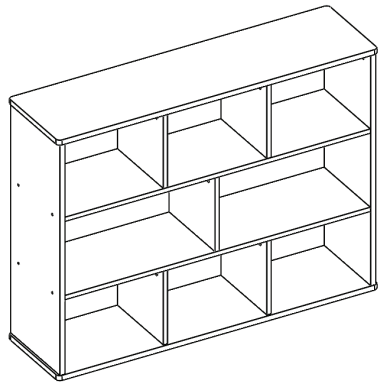
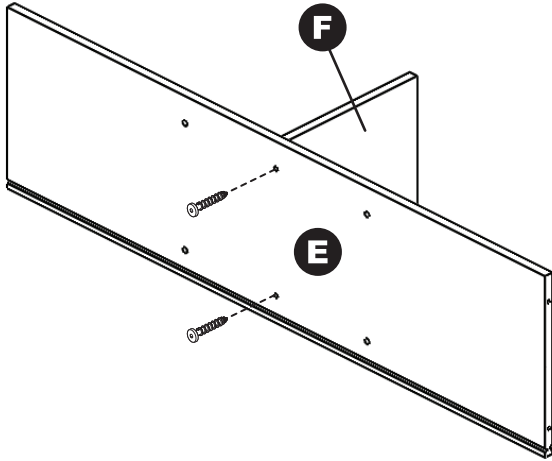
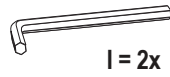
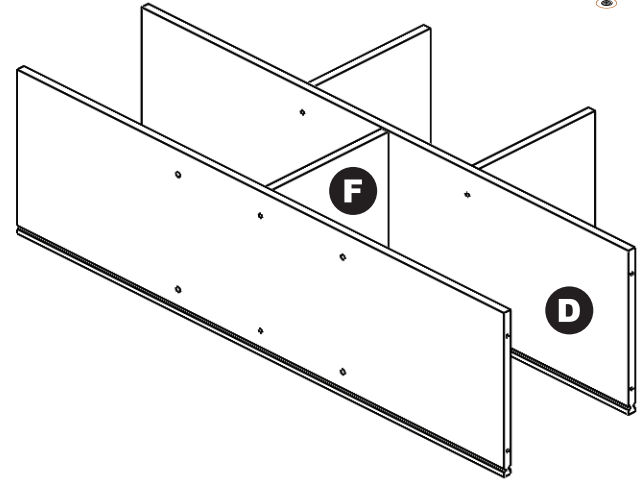
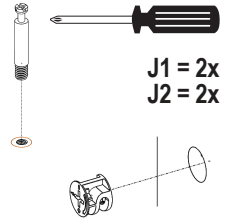
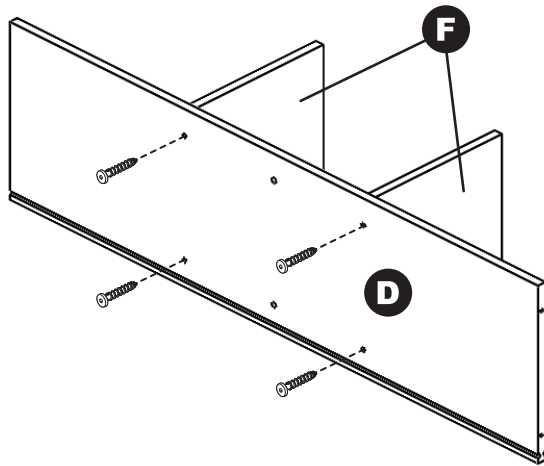
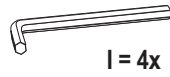
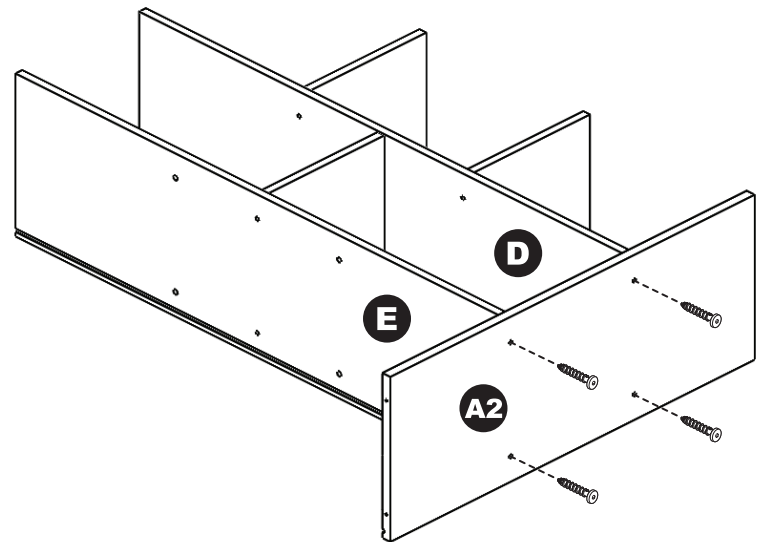
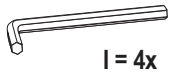

<p>A</p> <p>A1 A2</p>	<p>1x/1x F</p> <p>5x</p>
<p>B</p> <p>1x</p>	<p>G</p> <p>3x</p>
<p>C</p> <p>1x</p>	<p>H</p> <p>8x</p>
<p>D</p> <p>1x</p>	<p>I</p> <p>14x</p>
<p>E</p> <p>1x</p>	<p>J</p> <p>J1 J2</p> <p>14x/14x</p>
	<p>K</p> <p>1x</p>

1**3****2****4**

5

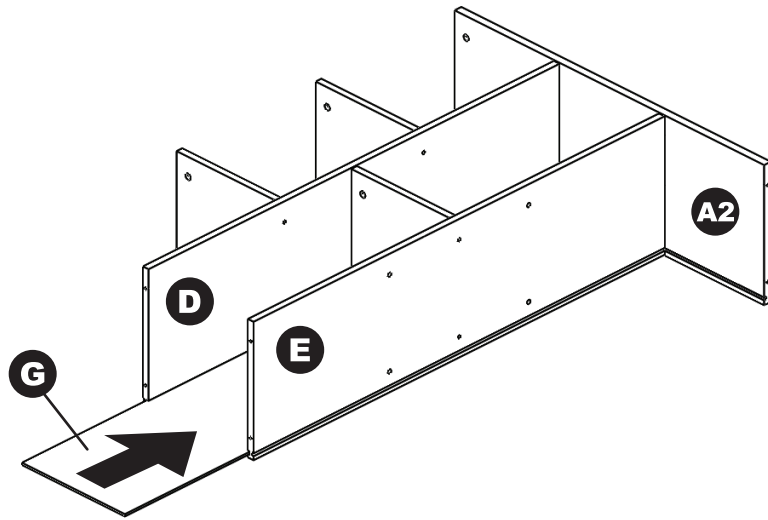

7

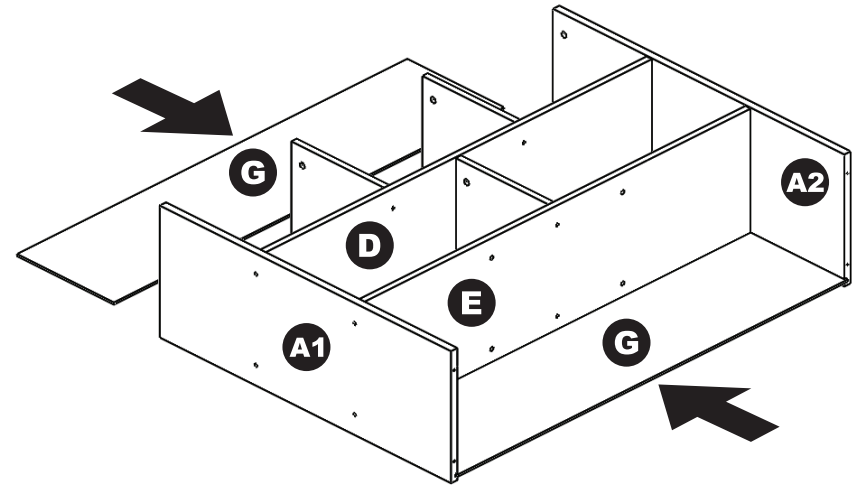

6

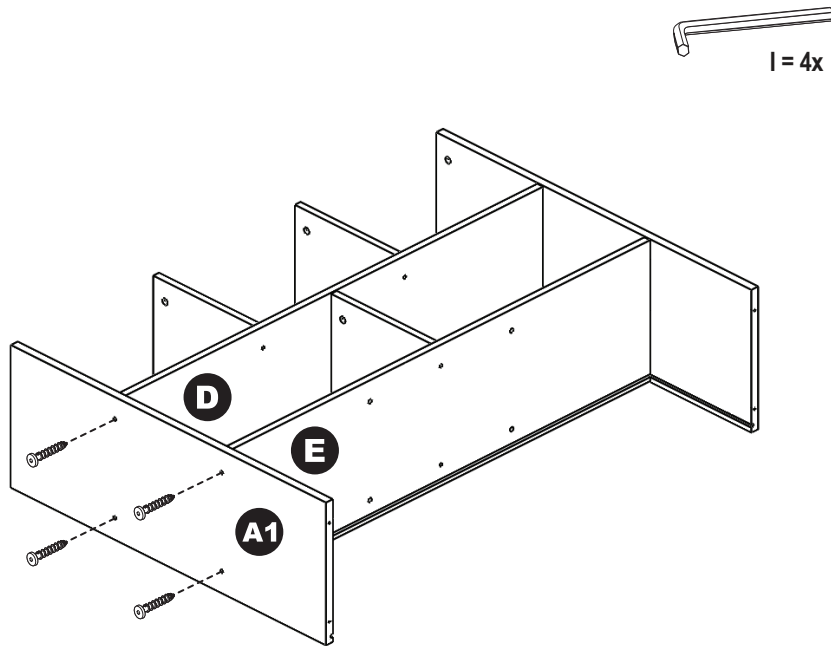

8

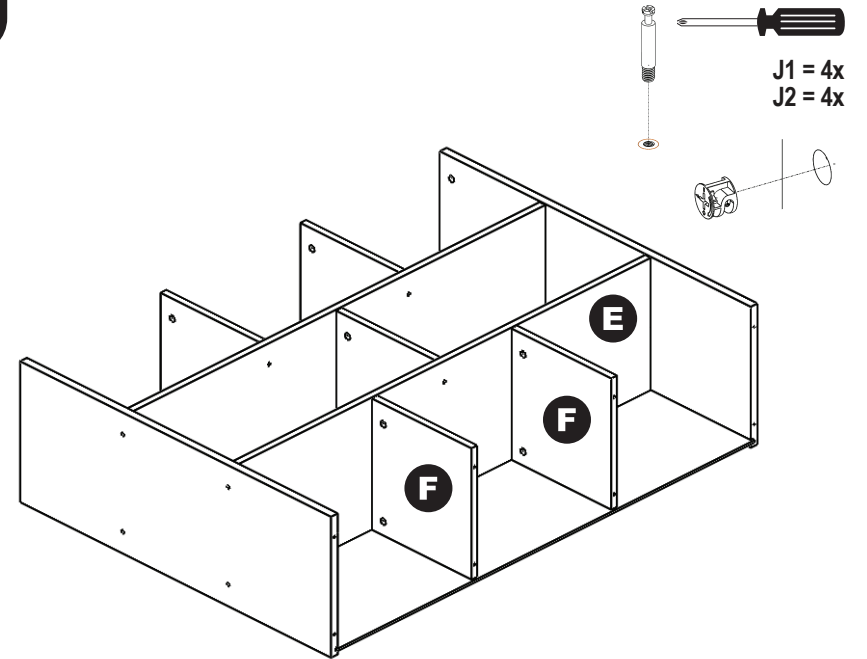

9



H = 8x

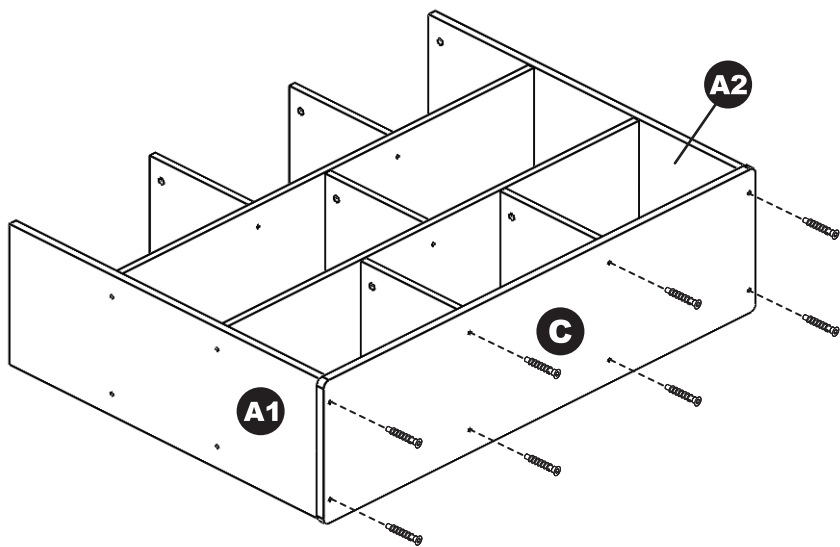

10

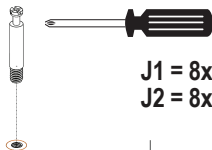

J1 = 8x
J2 = 8x

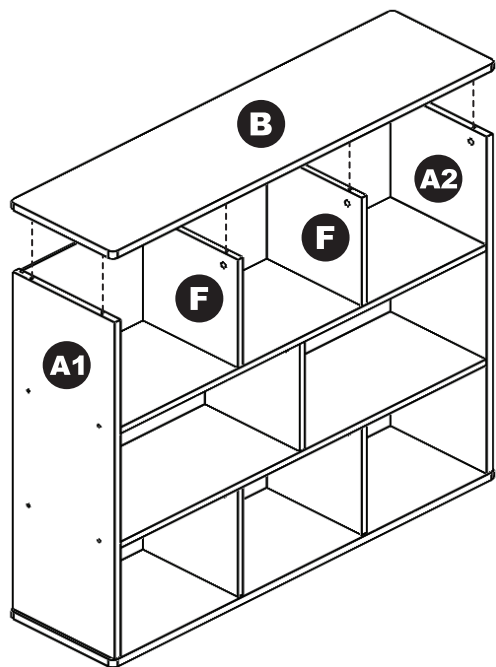



**QUESTIONS? CONTACT CUSTOMER SERVICE:
(866) 619-1776**

Care and Cleaning

Clean with a damp cloth or sponge using warm water and mild soap. Wipe dry.

Do not place near heat, moisture or vaporizer which may cause wood to warp and peel.

Check for loose or worn parts periodically and tighten or replace as necessary.

⚠ WARNING:

Adult Assembly Required.

Two adults recommended.

- ▲ Contains small parts, sharp points and edges.
- ▲ Do not stand, sit, kneel, climb, lean or pull on unit for support.
- ▲ Never leave children unattended.
- ▲ Do not place unit near high heat or moisture.
- ▲ Adult supervision recommended.

⚠ ADVERTENCIA:

Se requiere un adulto para su ensamblaje.

Se recomienda que lo hagan dos adultos.

- ▲ Contiene partes pequeñas, puntas y bordes filosos.
- ▲ No se pare, siente, arrodille, trepe, recline o jale la unidad como apoyo.
- ▲ Nunca deje a los niños sin atención.
- ▲ No coloque la unidad cerca de donde haya calor o humedad.
- ▲ Se recomienda que lo supervise un adulto.

⚠ AVERTISSEMENT :

L'assemblage nécessite un adulte.

Deux adultes recommandés.

- ▲ Contient des petites pièces, des parties pointues et des bords tranchants.
- ▲ Ne pas se mettre debout, s'asseoir, s'agenouiller, monter, s'appuyer ou pousser sur l'unité pour se soutenir.
- ▲ Ne jamais laisser les enfants sans surveillance.
- ▲ Ne pas installer l'unité à côté d'une source de chaleur ou d'humidité.
- ▲ La surveillance par un adulte est recommandée.



▲ **WARNING:** Choking Hazard – Small parts.
Not for children under 3 years.

▲ **ADVERTENCIA:** Peligro de asfixia – Partes pequeñas.
No apto para niños menores de 3 años.

▲ **AVERTISSEMENT :** Risque d'étouffement - Petites pièces.

Ne convient pas aux enfants de moins de 3 ans.

