

ASSEMBLY INSTRUCTIONS COFFEE TABLE

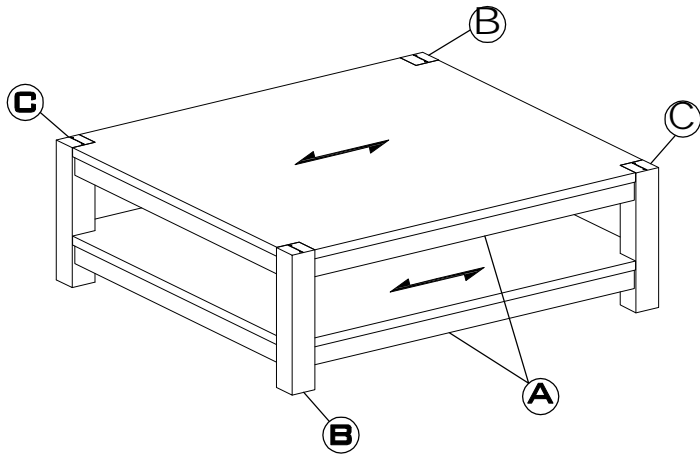

PARTS CHECK LIST

CODE	COMPONENTS	QTY
Ⓐ	TABLE TOP	x02
Ⓑ	RIGHT LEG	x02
Ⓒ	LEFT LEG	x02

Hardware Check List

code	description	qty
01	BOLT	x08
02	SPRING WASHER	x08
03	FLAT WASHER	x08
04	ALLEN KEY	x01

- PLEASE DO NOT DISCARD ANY OF THE PACKAGING UNTIL YOU HAVE CHECKED ALL THE PARTS AND THE PACKS OF HARDWARE.
 - BEFORE YOU BEGIN TO ASSEMBLE YOUR NEW PIECE OF FURNITURE, PLEASE CHECK TO ENSURE THAT ALL PARTS HAVE BEEN SUPPLIED.
 - FOLLOW INSTRUCTIONS CLOSELY AS DEVIATION FROM THEM MAY VOID YOUR WARRANTY AND PRESENT A POSSIBLE SAFETY RISK.
 - IT IS RECOMMENDED THAT ASSEMBLY IS DONE ON A SOFT SURFACE LIKE CARPET TO AVOID ANY DAMAGE.
 - PERIODICALLY CHECK AND RE-TIGHTEN ANY FASTENERS. WIPE DOWN ALL SURFACES WEEKLY WITH A CLEAN CLOTH. DO NOT CLEAN ANY SURFACES WITH HARSH ABRASIVES OR CHEMICALS.

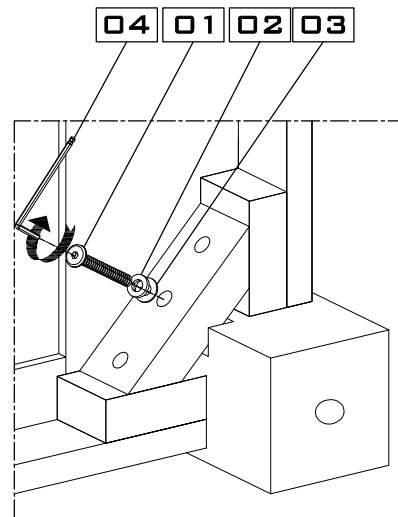
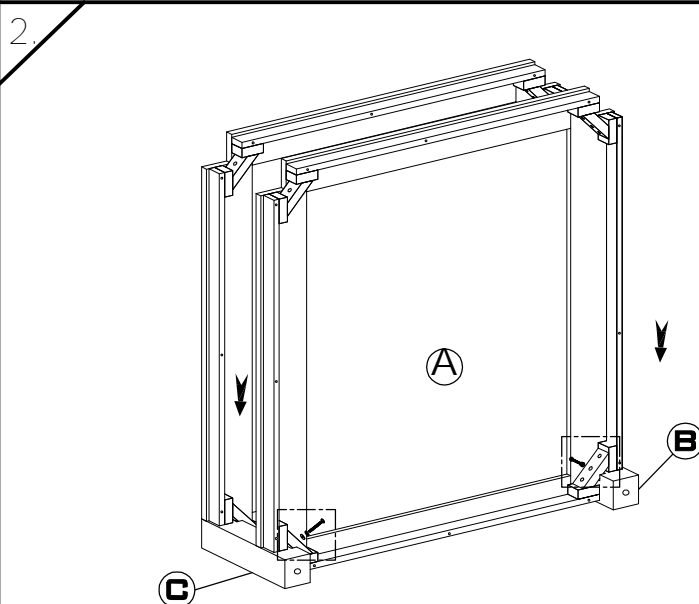
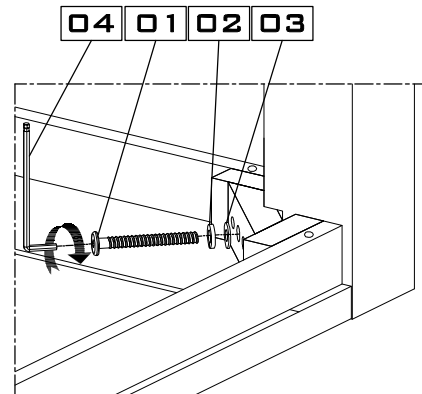
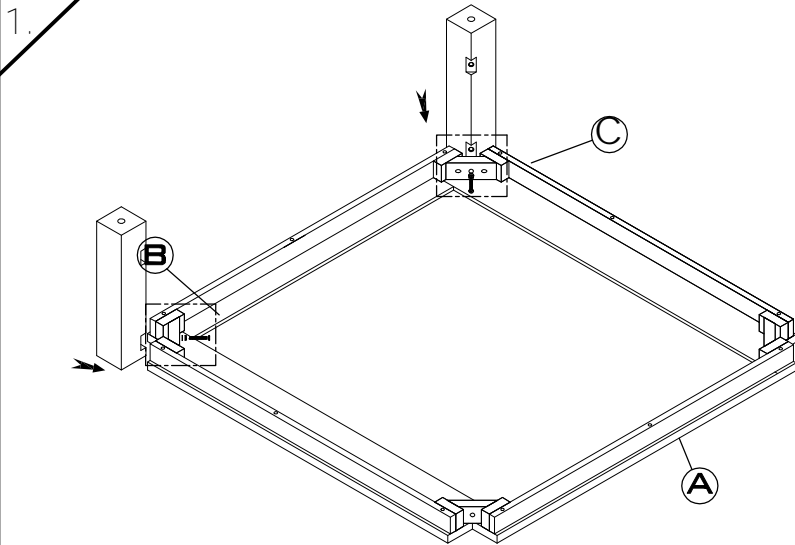

ASSEMBLY INSTRUCTIONS ADLER SQUARE COFFEE TABLE

3.

04

01

02

03

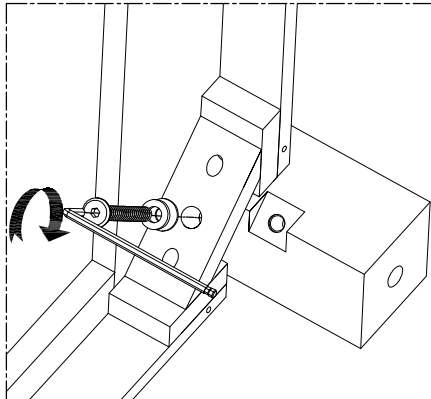
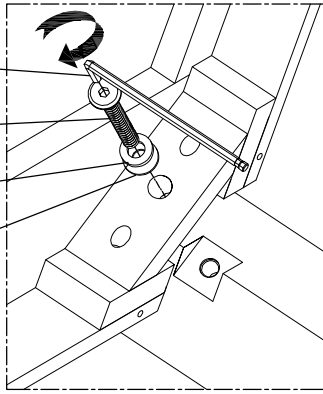

B

C

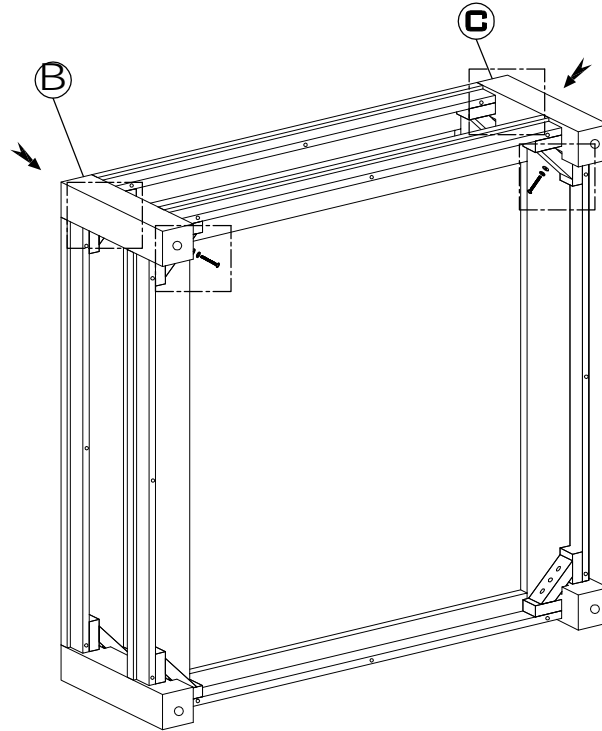

75%



4.

04

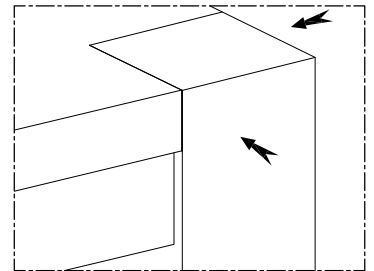
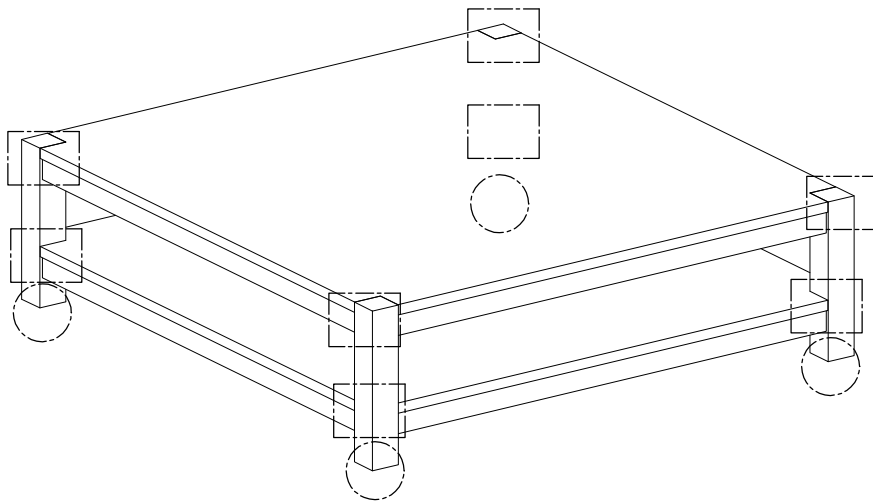
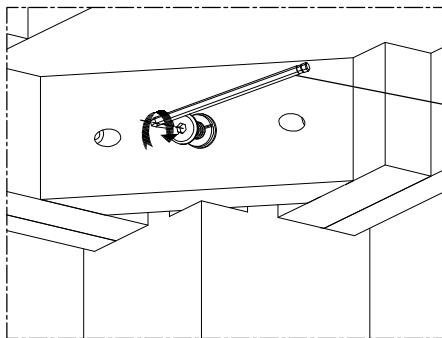

100%



ADJUST
FEET LEVELERS

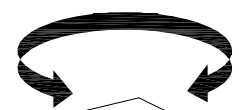

***ROTATE THE TABLE UPRIGHT. ALIGN EACH
LEG ON BOTH SIDES. THEN FULLY TIGHTEN ALL BOLTS.**