

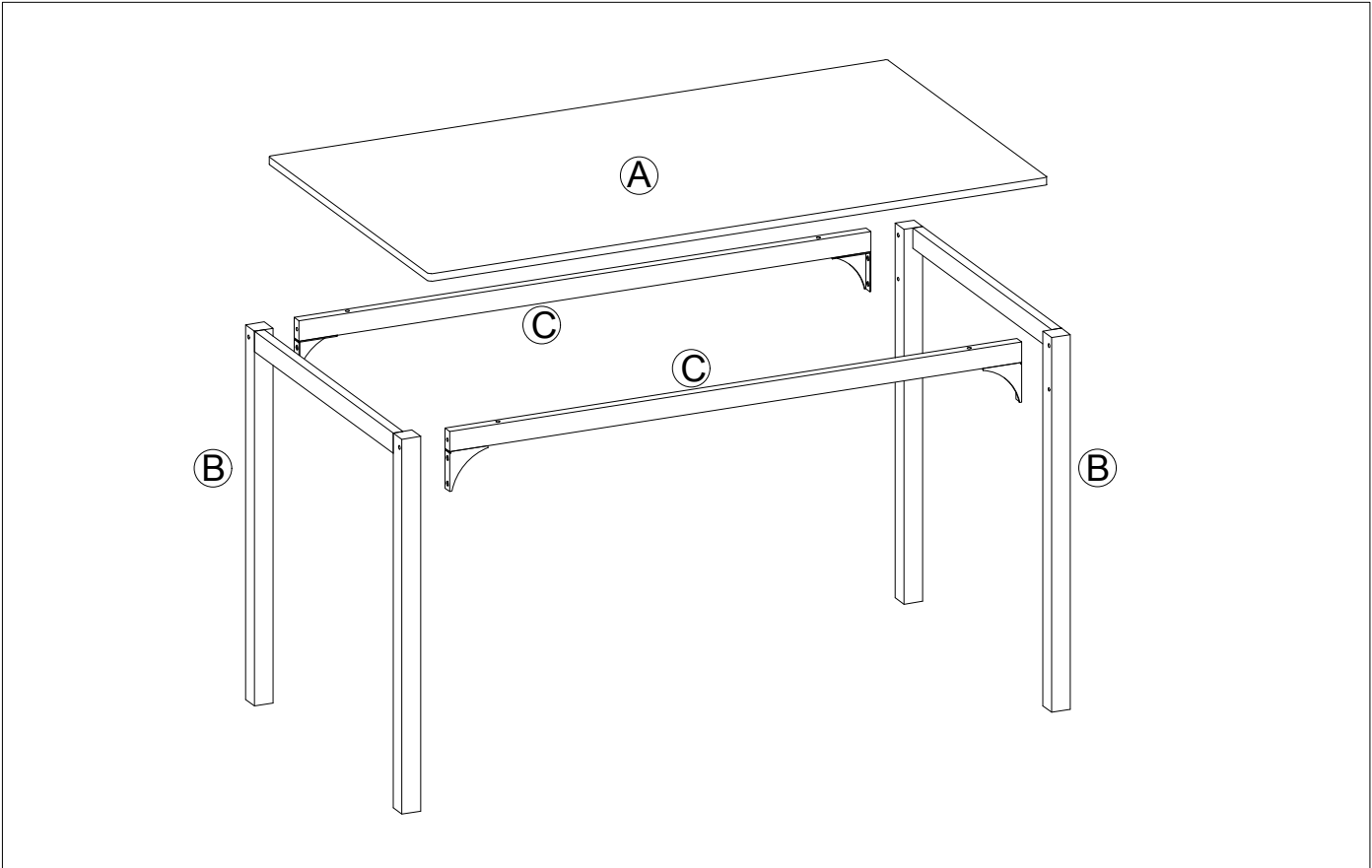

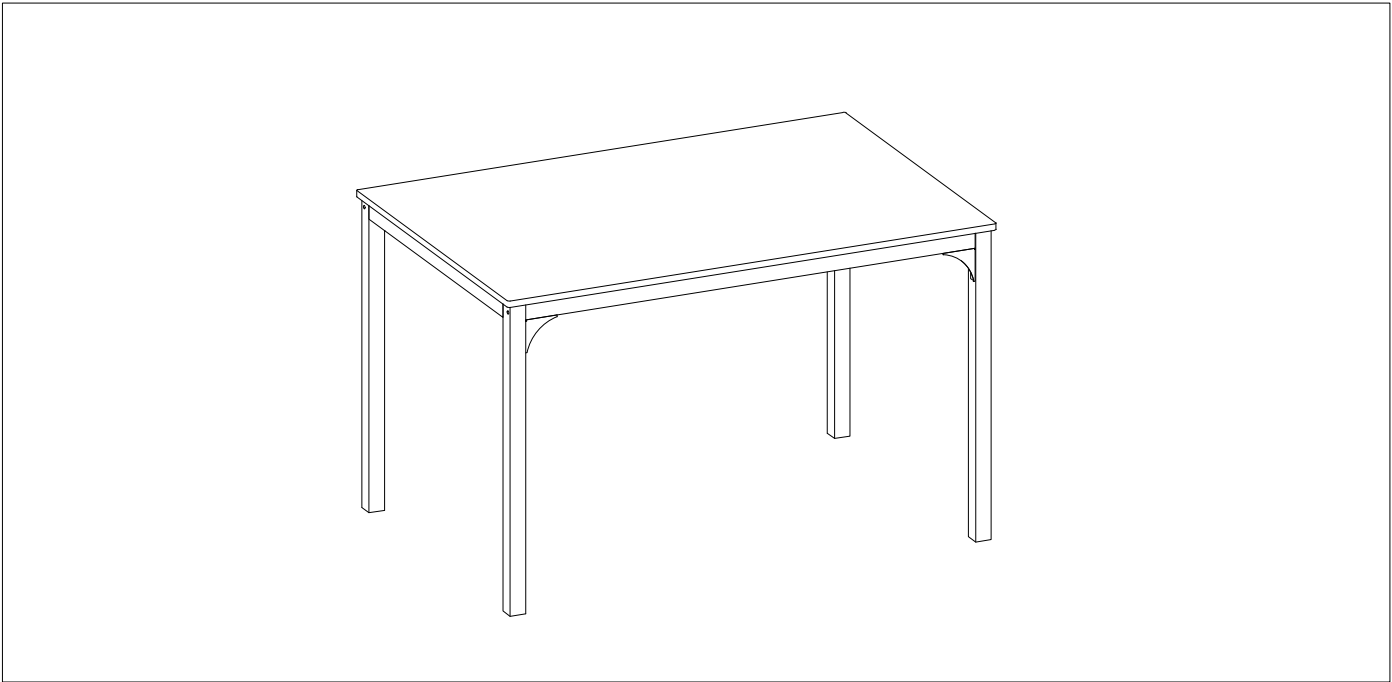

ASSEMBLY INSTRUCTIONS

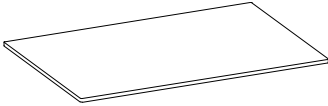
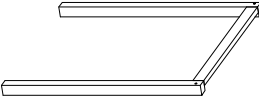

part list

	
A×1PC	B×2PCS
	
C×2PCS	

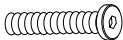
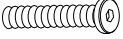

hardware list

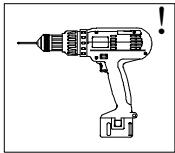
 M6×12mm ①×4PCS	 M6×50mm ②×4PCS
 M6×55mm ③×4PCS	 M4 ④×1PC



PLEASE BE CAREFUL DO NOT DAMAGE THE HOLE POSITION WHEN YOU USE POWER TOOLS !

Step 1

 M6×12mm ①×4PCS	 M6×55mm ③×4PCS
--	--

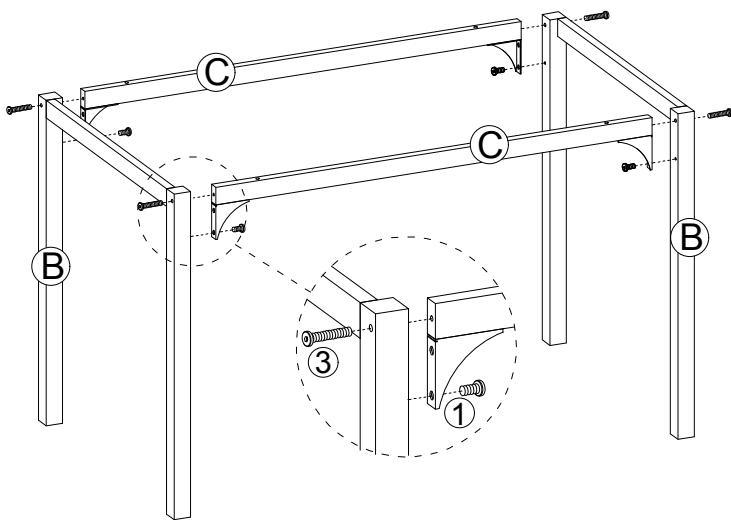

Step 2

 M6×50mm ②×4PCS
--

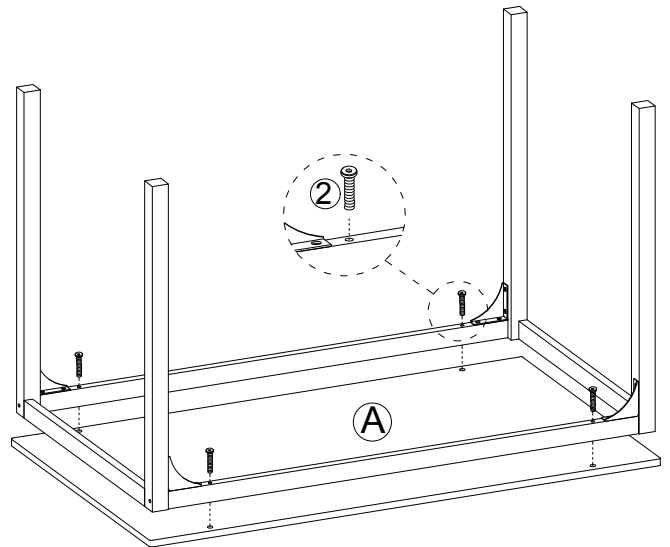

Step 3

