

# Assembly Manual

## TV Stand

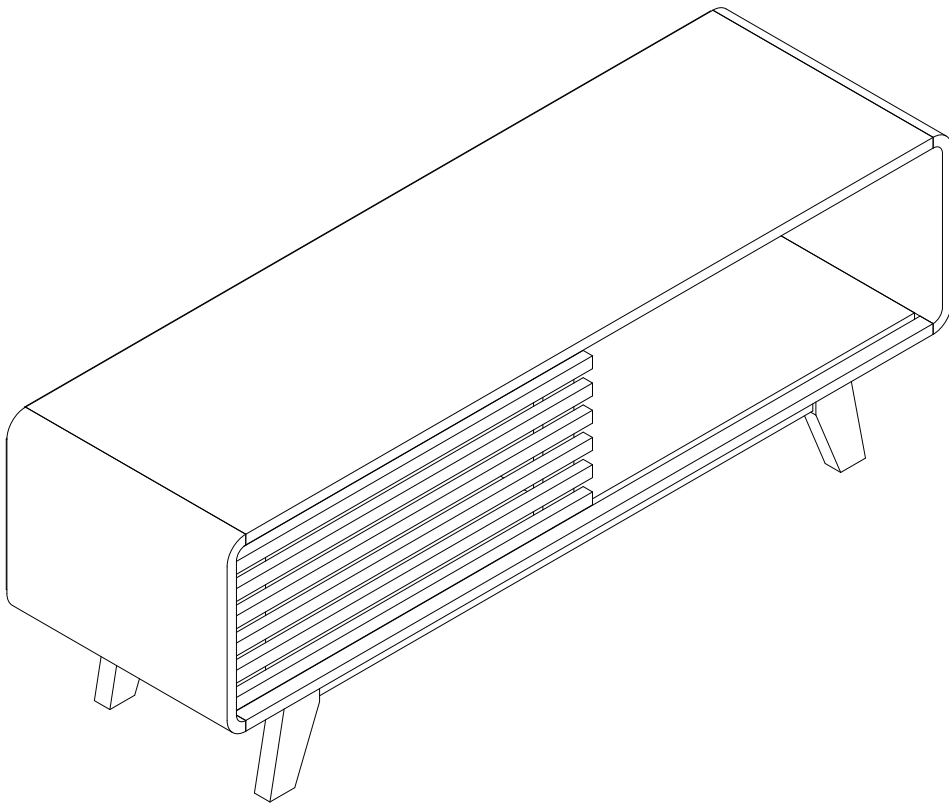

Please read this manual carefully before any operation and keep it properly for future use.

If any problems on our product, please feel free to contact us

# Exploded View

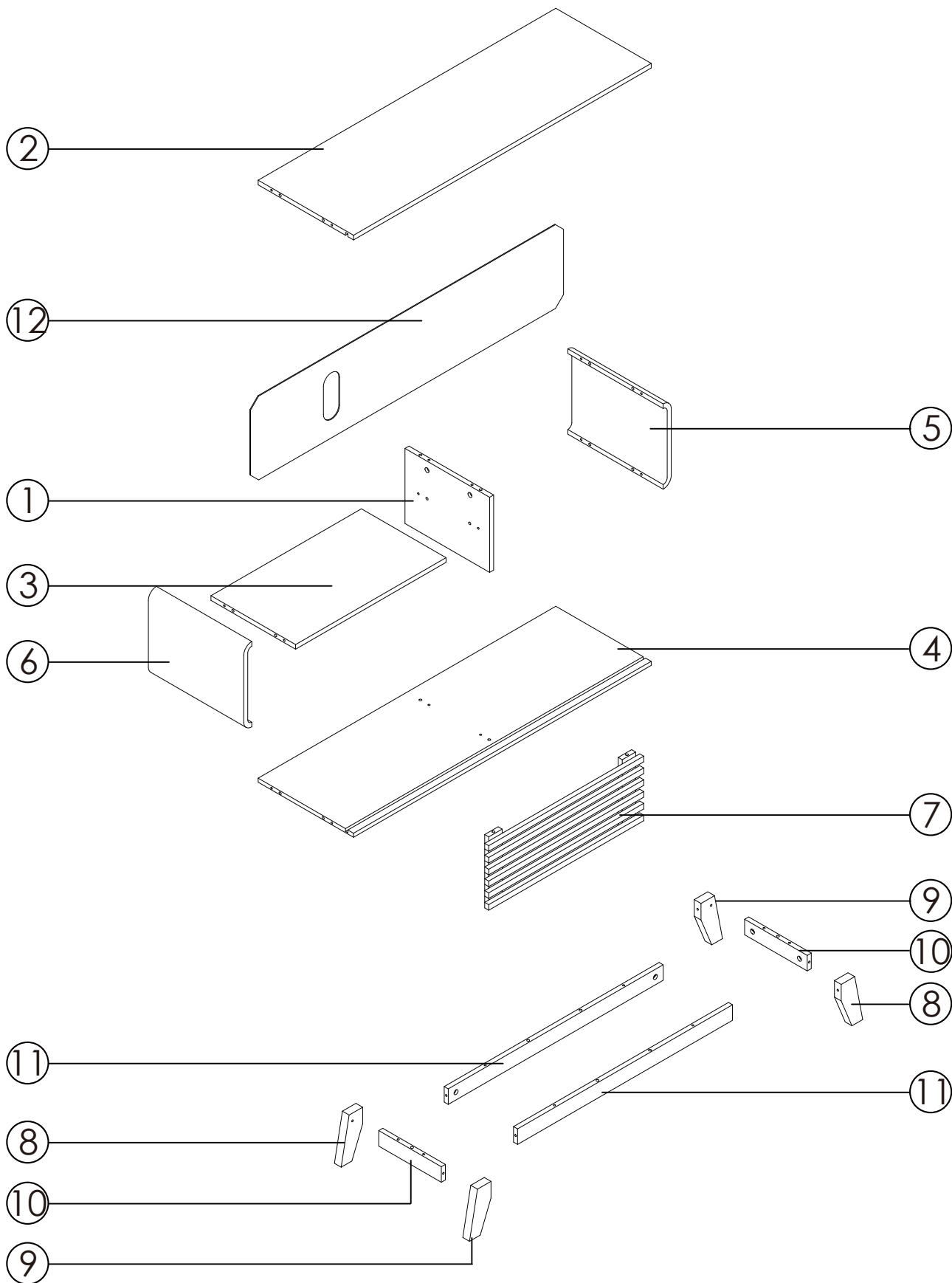

# Components List

30 min

Assembly Time



One People

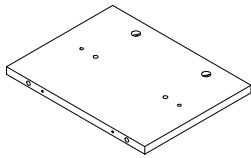

1  
(X1)

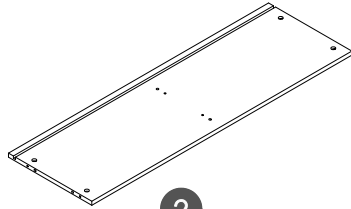

2  
(X1)

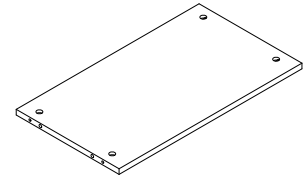

3  
(X1)

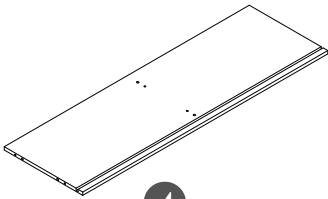

4  
(X1)

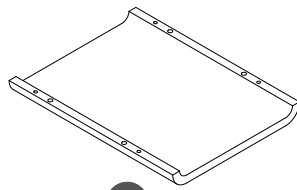

5  
(X1)

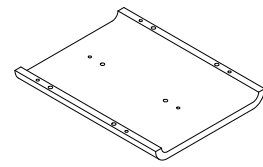

6  
(X1)

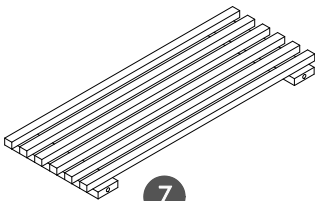

7  
(X1)

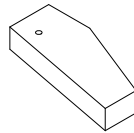

8  
(X2)

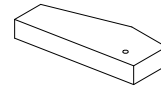

9  
(X2)

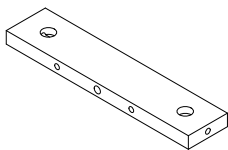

10  
(X2)

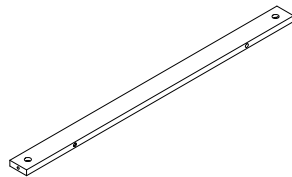



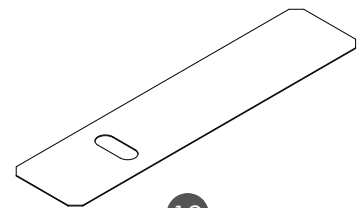

11  
(X2)

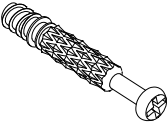

12  
(X1)

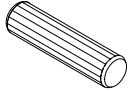
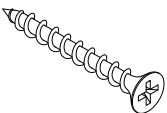
# Components list

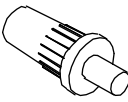
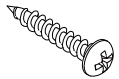
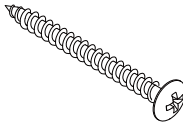
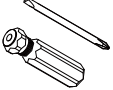
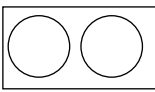
<b>A</b>			<b>B</b>			<b>C</b>		
								
Cam lock pin	M7x39	22+2	Klix cam	M15x12	22+2	Wooden dowel	M8x30	22+2
<b>D</b>			<b>E</b>			<b>F</b>		
								
Screw	M5x40	2+1	Foot nail		4+1	Door glider		4
<b>G</b>			<b>H</b>			<b>I</b>		
								
Screw	M3x16	16+2	Screw	M5x50	8+1	Screwdriver		1
<b>J</b>								
								
Decorative sticker		1						

## Note:

- (1) The number after "+" sign indicates the extra piece(s).
- (2) How to use the 2-in-1 screwdriver with interchangeable Phillips and flat head bits:
  - (a) Insert the desired bit end (Phillips or flat head) into the handle and push firmly until it clicks into place. To remove the bit, push and hold the spring-loaded ring on the handle towards the base. This will release the bit from the handle.
  - (b) While still depressing the ring, pull the bit out of the handle. To replace with the opposite bit end, insert it into the handle until it clicks into the locking position. Make sure the bit is fully inserted before use.

# Assembly Instruction

STEP 1

Attach cam lock pins(A) into the boards(1&2) using screwdriver(I).

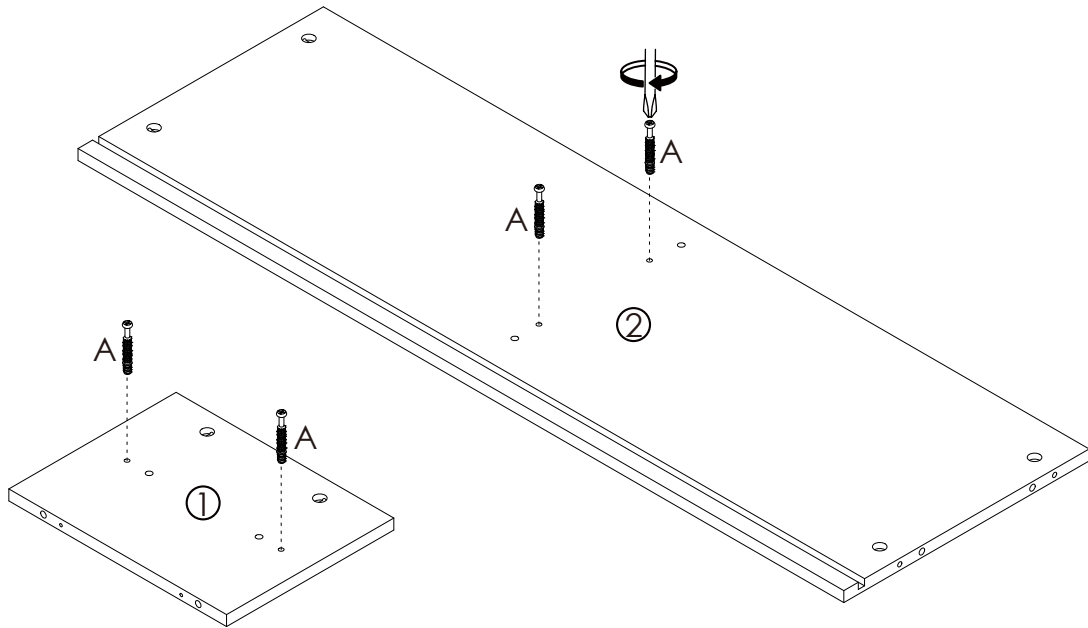

A\*4



I\*1

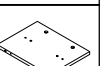

1\*1



2\*1

STEP 2

Insert the cam locks(B) and wooden dowels(C) into the board(1), then connect the boards(1&2), lock them tightly using screwdriver(I), put the Decorative stickers(J) on the hole of cam locks.

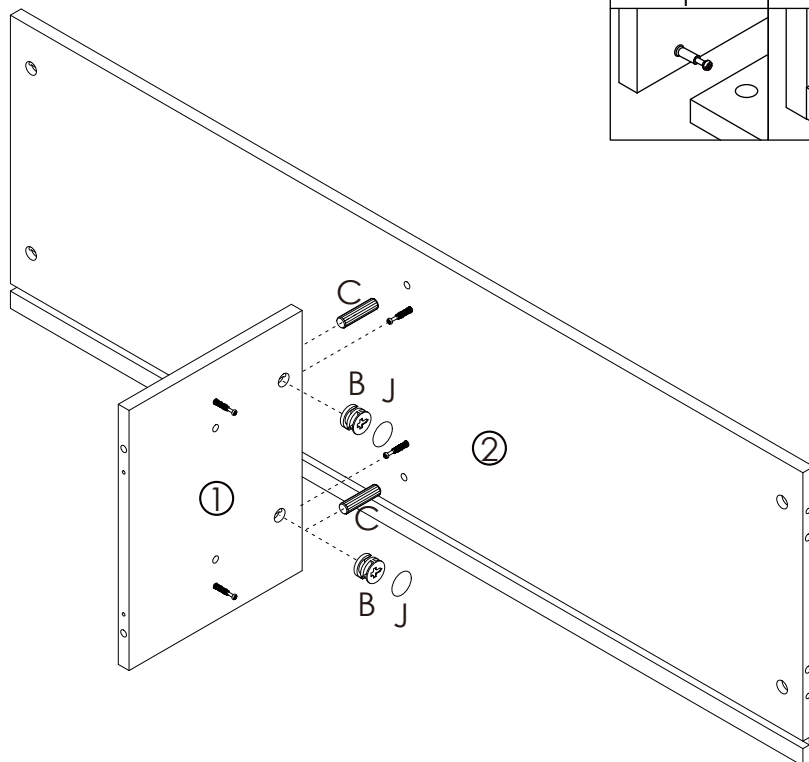

B\*2



C\*2



I\*1



J\*1

# Assembly Instruction

STEP 3

Insert the cam locks(B) and wooden dowels(C) into the board(3), then connect the boards(1&3), lock them tightly using screwdriver(I).

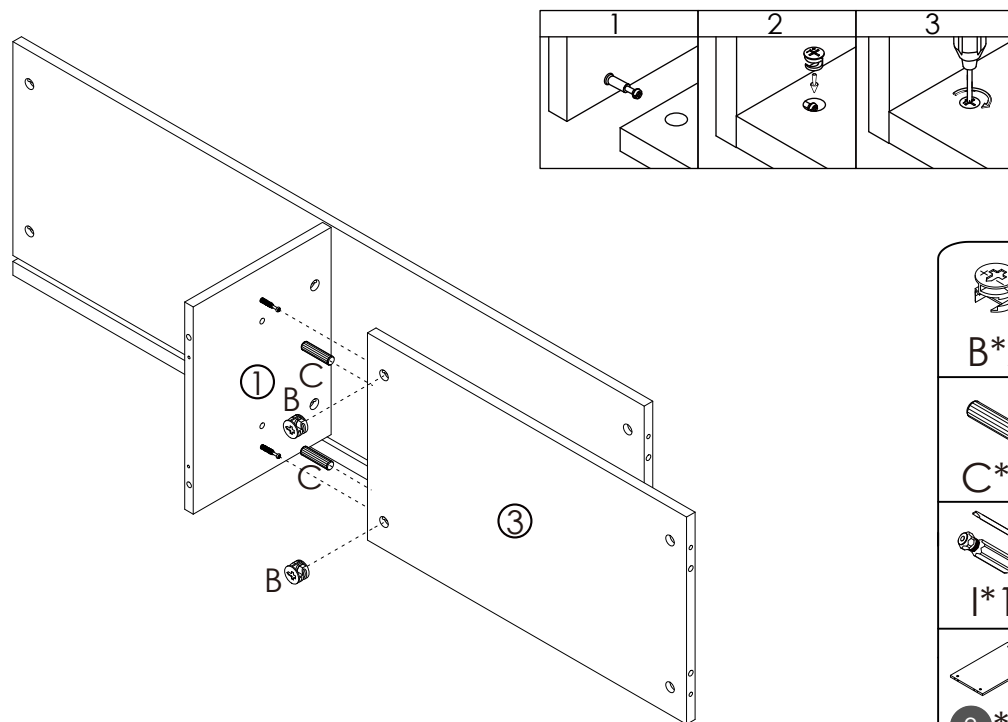

STEP 4

Insert the wooden dowels(C) into the board(1), then attach the board(4) to the board(1) using screws(D) and screwdriver(I).

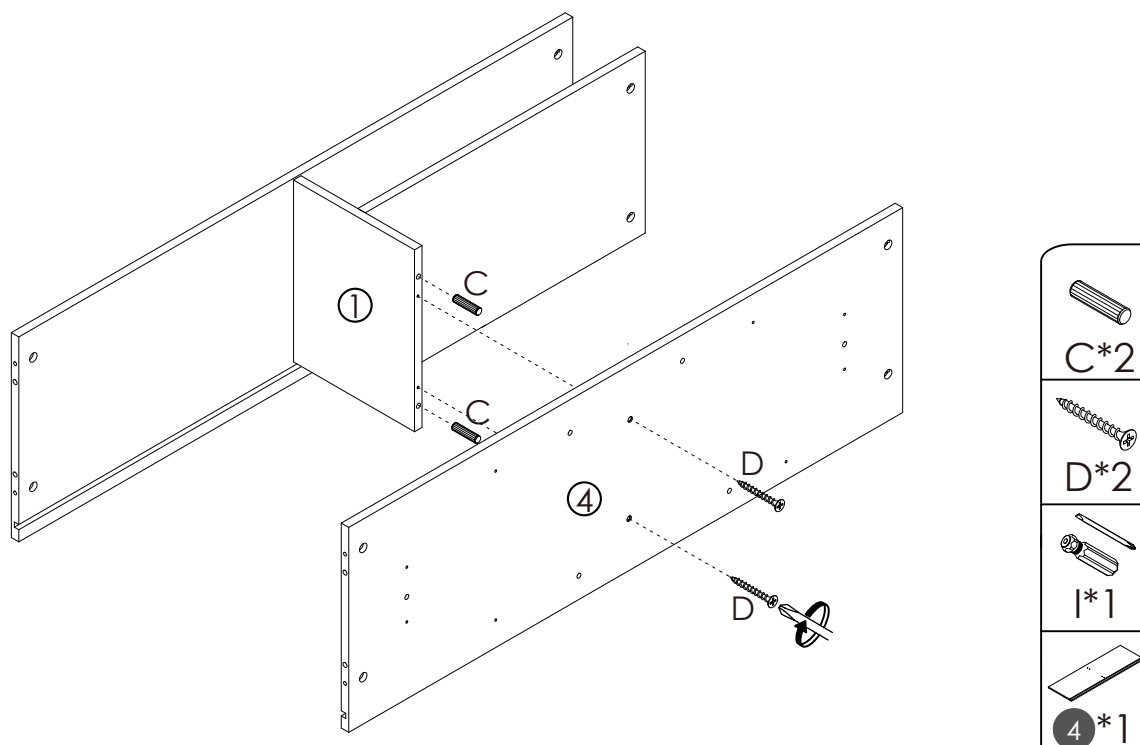

# Assembly Instruction

STEP 5

Insert the cam bolts(A) into the boards(5&6) and rotate them tightly using screwdriver(I).

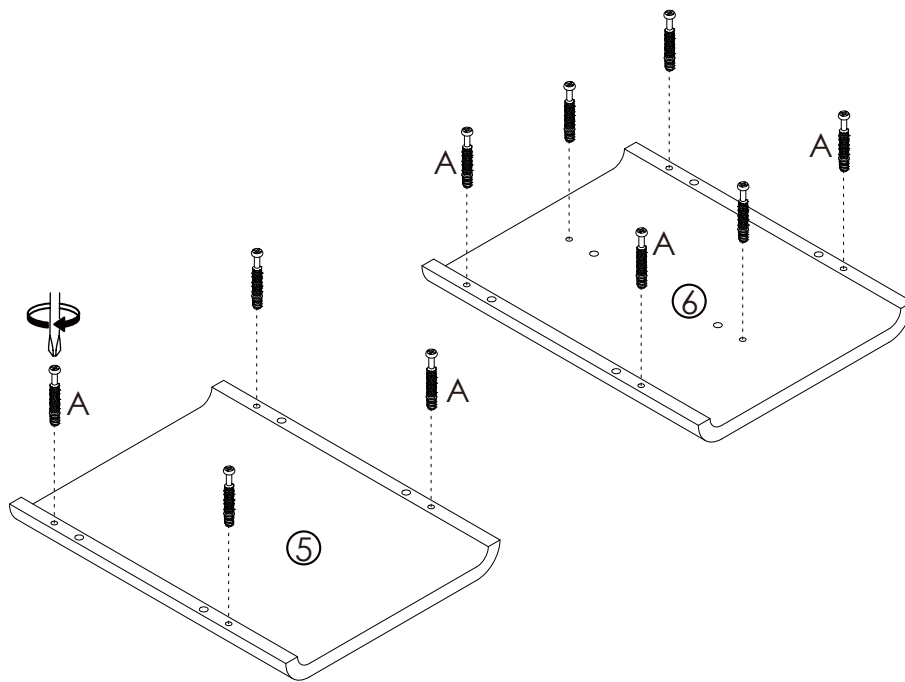

A\*10



I\*1

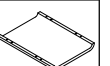

5\*1

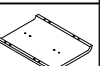

6\*1

STEP 6

Insert the wooden dowels(C) into the boards(2&3&4).

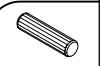
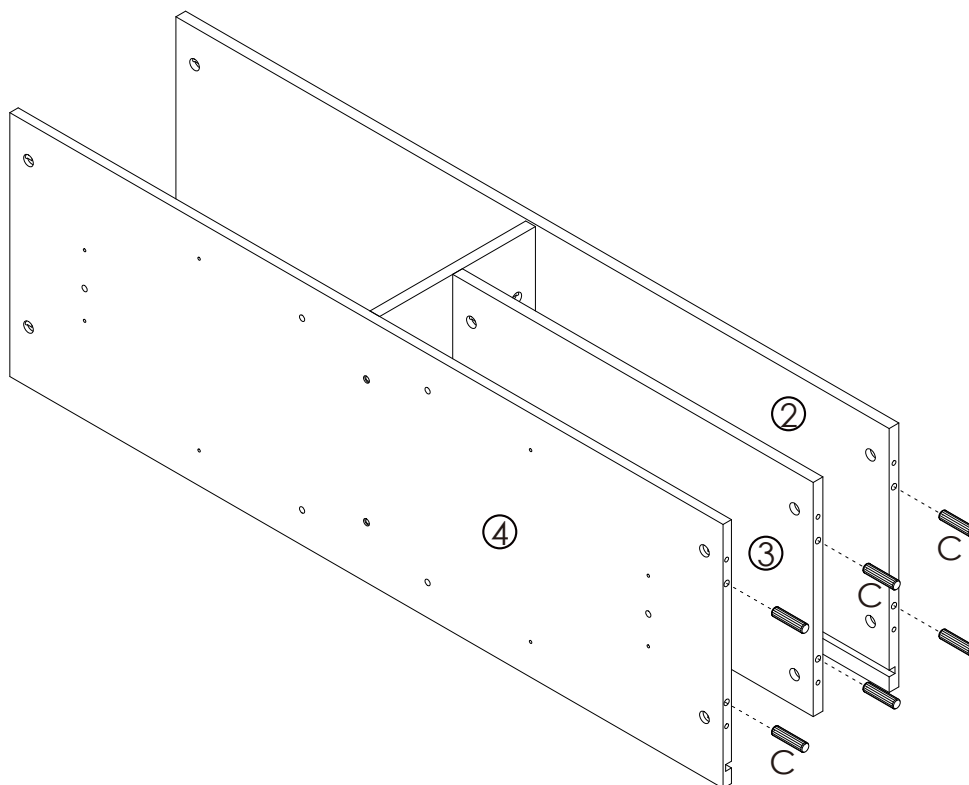

C\*6

# Assembly Instruction

STEP 7

Insert the cam locks(B) into the boards(2&3&4), then attach the board(6) to the boards(2&3&4), lock them tightly using screwdriver(I).

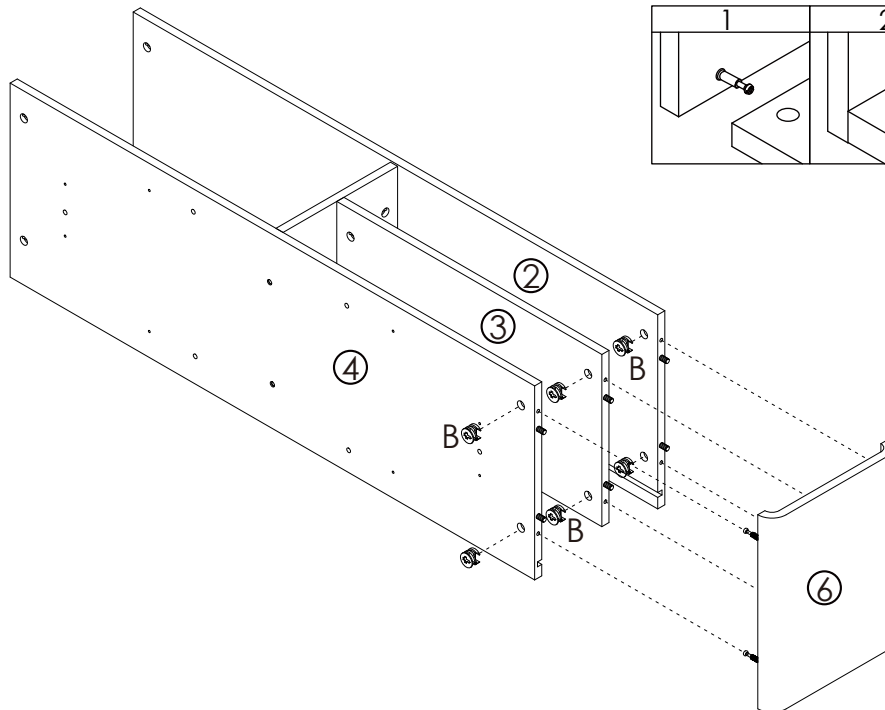

STEP 8

Insert the door gliders(F) into the door panel(7).

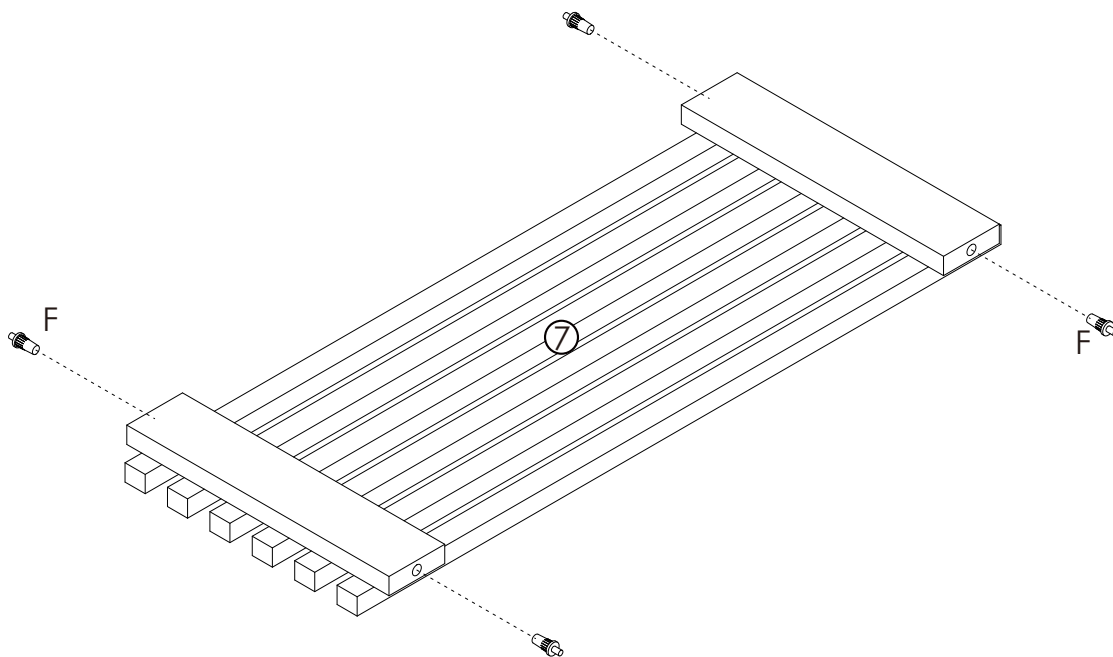

# Assembly Instruction

STEP 9

Slide the door panel(7) into the rail between the boards(2&4).

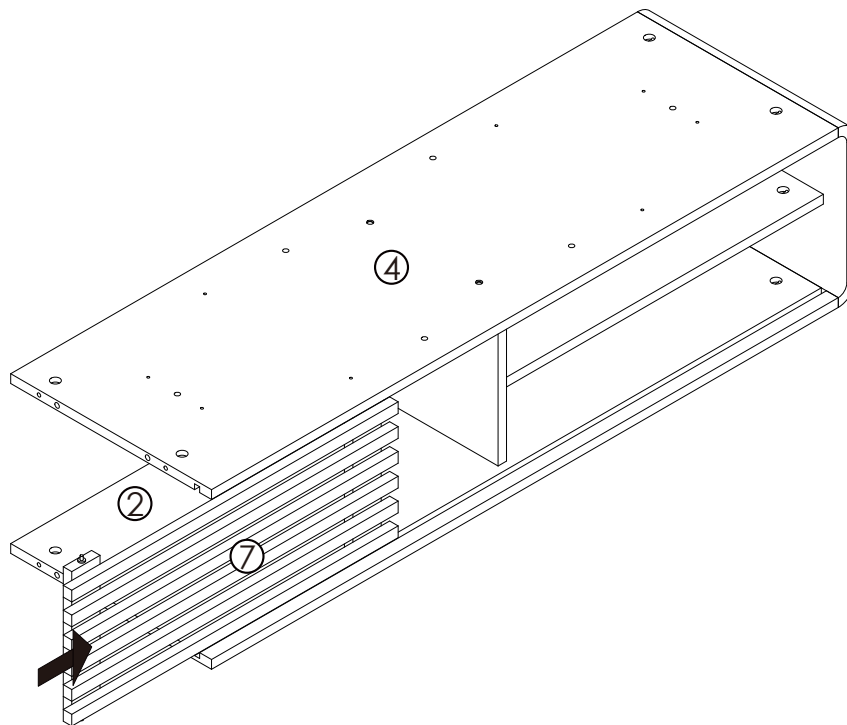

STEP 10

Insert the cam locks(B) into the boards(2&4), then attach the board(5) to the boards(2&4), lock them tightly using screwdriver(I).

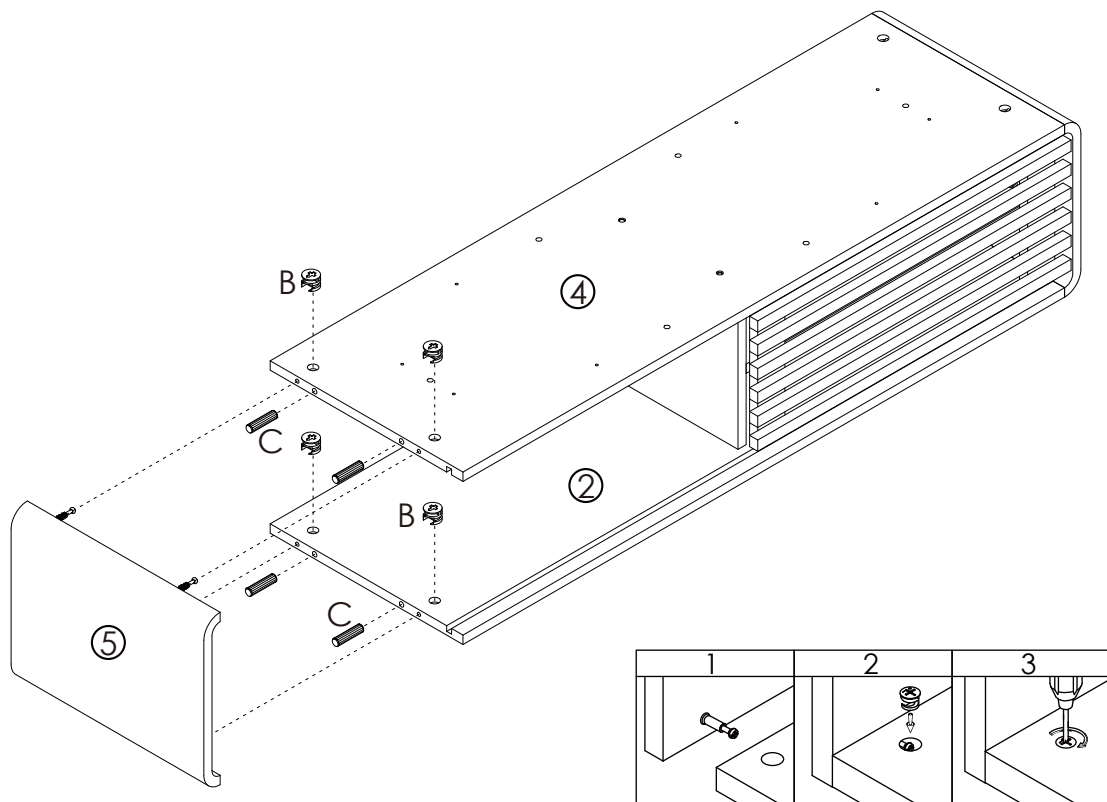

B\*4



C\*4



I\*1

# Assembly Instruction

STEP 11

Insert the cam bolts(A) into the feet(8&9).

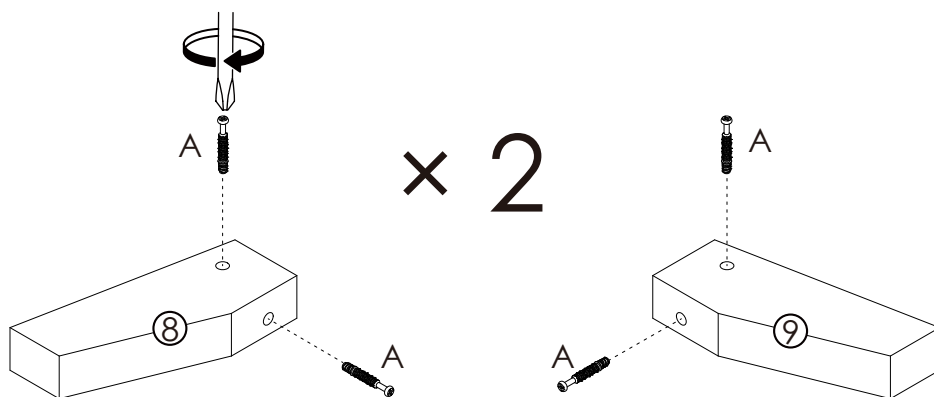

A\*8



I\*1



8\*2



9\*2

STEP 12

Insert the cam locks(B) into feet(8&9) , then attach the boards(10)to the feet(8&9) , lock them tightly using screwdriver(I).

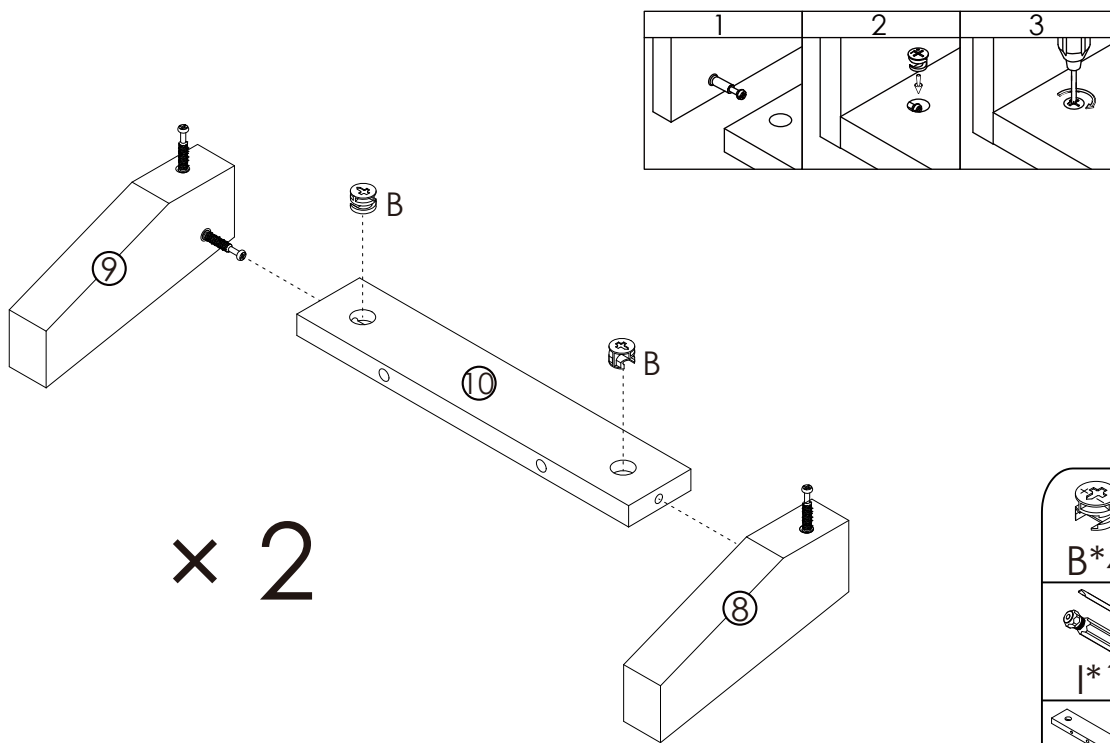

B\*4



I\*1



10\*2

# Assembly Instruction

STEP 13

Insert the cam locks(B) into the board(11), then attach the feet(8&9) to the boards(11), lock them tightly using screwdriver(I).

It's normal that the frame currently not stable, but after finishing the step 15(attaching the bottom frames with legs to the bottom board using screws. It will be stable enough!

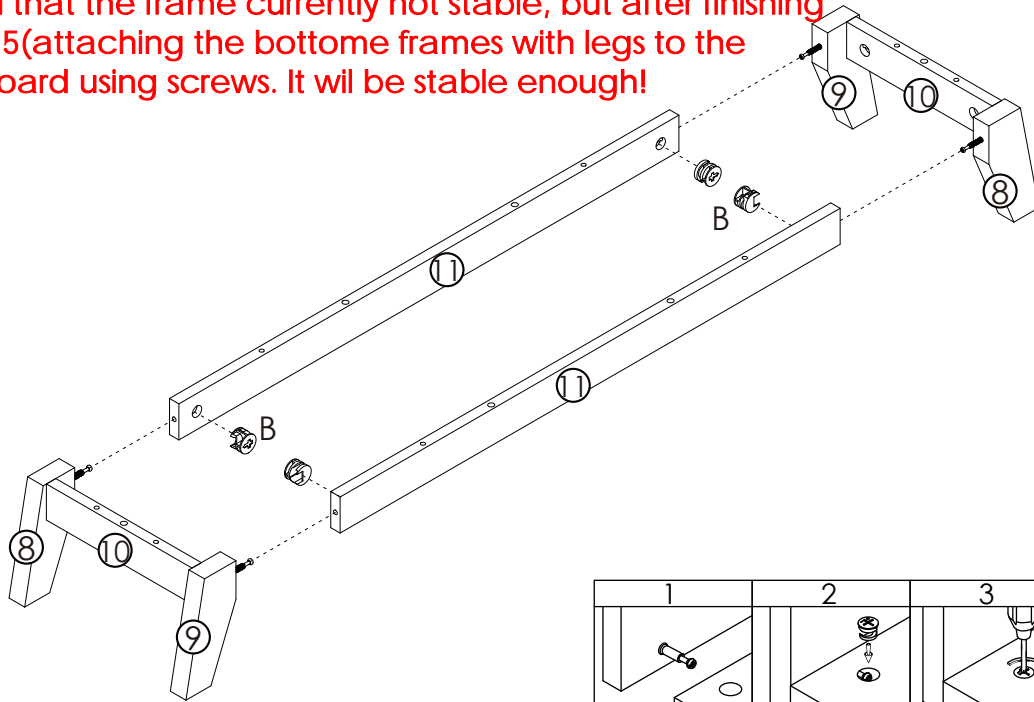

B\*4

I\*1

11\*2

STEP 14

Insert the wooden dowels(C) into the boards(10&11).

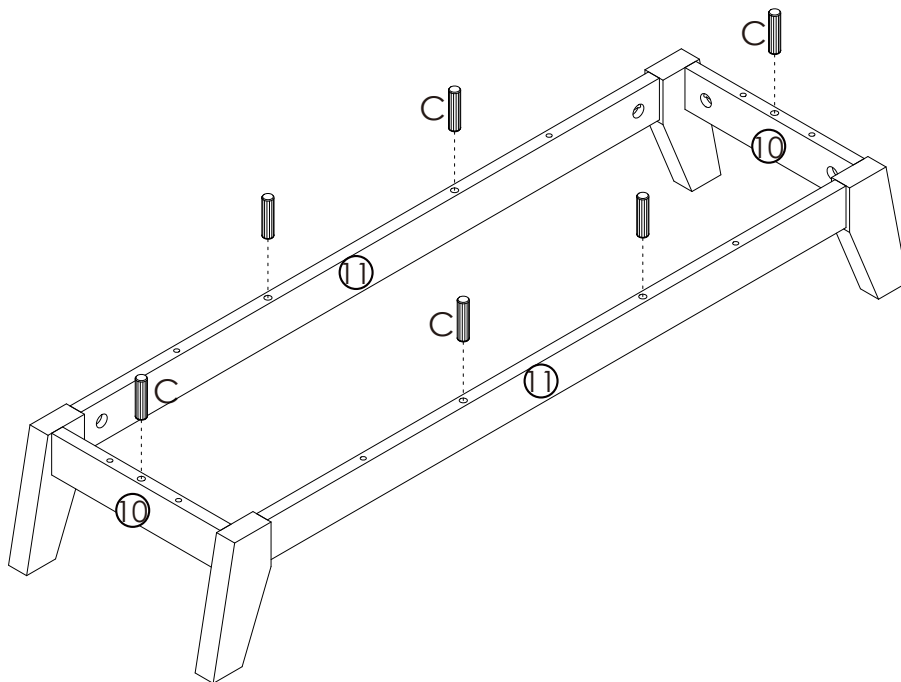

C\*6

# Assembly Instruction

STEP 15

Attach the frame(10&11) to the bottom panel using screws(H) and screwdriver(I).

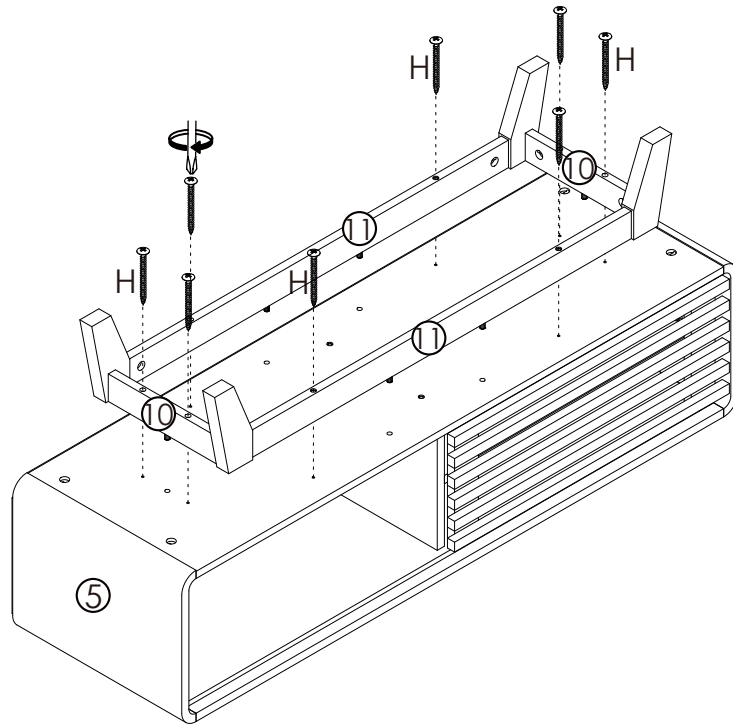

STEP 16

Insert the foot nails(E) into the bottom of feet(8&9).

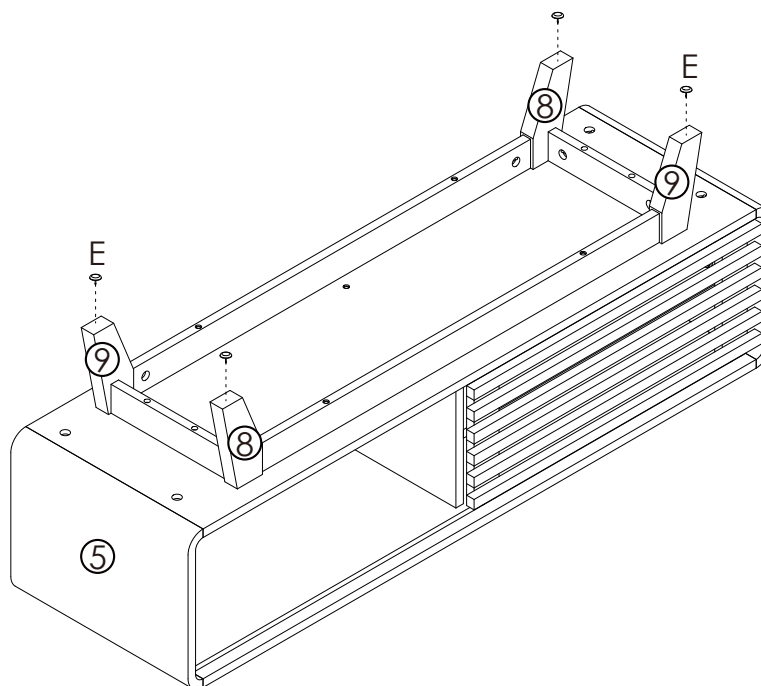

# Assembly Instruction

STEP 17

Lock the back panel(12) using screws(G) and screwdriver(I).

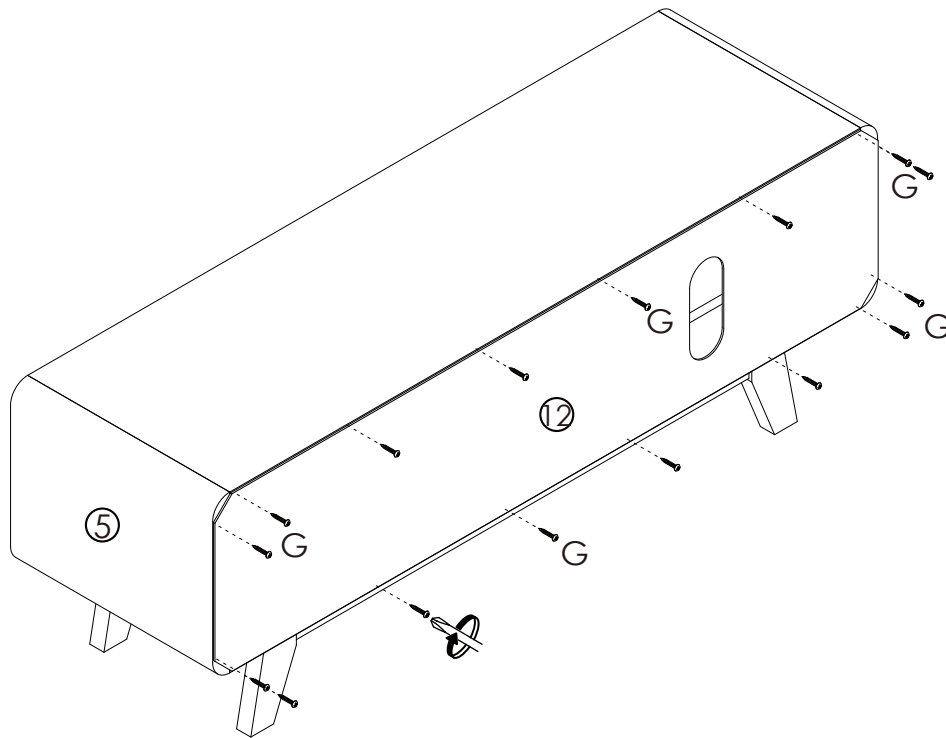

G\*16

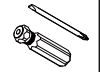

I\*1

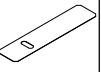

12\*1

STEP 18

The assembly is complete.

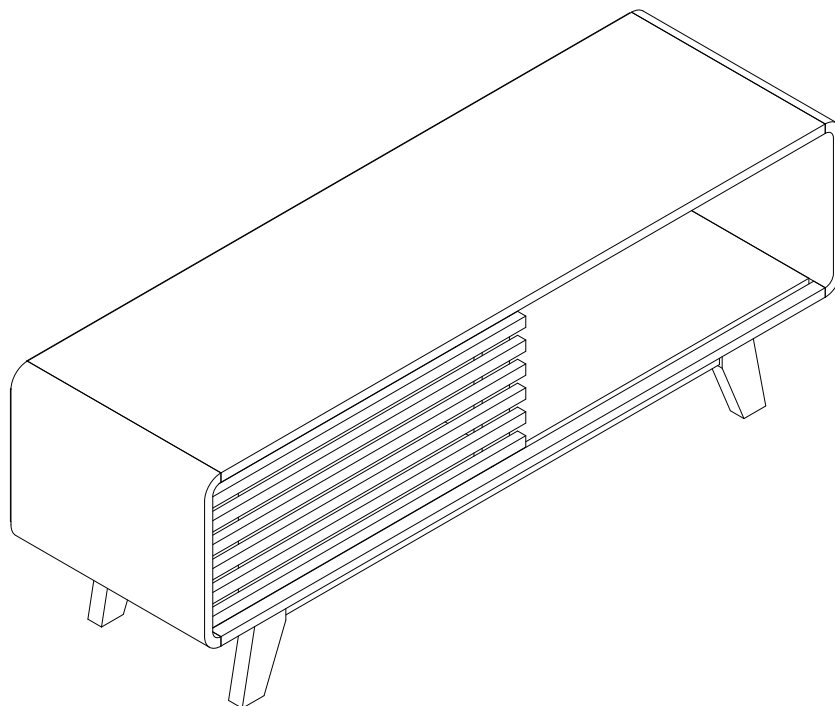

## **Warning**

- Please keep the product away from children while assembling.
- Do not let children play or jump on the product.
- Do not stand on the item or use it as a step ladder.
- Prior to use, please check for any loosening screws or parts.
- Make sure that each screw and part is correctly installed and securely fastened.

## **Care and Maintenance**

- Use a soft clean cloth that will not scratch the surface when dusting.
- There's no need to use furniture polish, you need to, test it first in an inconspicuous area.
- Using solvents of any kind on your furniture may damage the finish.
- Never use water to clean your furniture as it may cause damage to the finish.
- Liquid spills should be removed immediately.
- Gently blot the spill with a soft, clean cloth to avoid rubbing.

## **Further advice about the furniture care**

- It is best to keep your furniture in a climate-controlled environment.
- Extreme temperatures and humidity changes can cause fading, warping, shrinking and spitting of wood.
- We recommend keeping furniture from sunlight exposure to avoid possible surface damage.
- Proper maintenance and cleaning at home will extend the life of your purchase.
- Following these important and helpful tips will help retain your furniture's performance even it ages.
- Periodically (every 90 days), make sure the screws are fully tightened.

## Warmly after-sales service

- Please check all the hardware and furniture before assembling.
- If anything is missing, please feel free to contact us. If you only leave a message on the platform, we may not be able to effectively solve the problem.
- Timely communication helps us understand your situation and provides you with the best shopping experience.

Have a question for our company?

Thank you for supporting our company.

- If you have any issues with your purchase, please feel free to let us know.
- We will always do our best to work out a solution that you will be happy with.

## Return Policy

Length of return period:

Items can be returned within 30 days of receipt of shipment. Who is responsible for the return shipping fee?

We will cover the return shipping fees if:

1. The item received is damaged or defective.
2. The wrong item was shipped to you.
3. The item received is materially different from what was described on the product page.

If the return is for any other reason, the customer will be responsible for the return shipping fees.

However, we always hope to work with you to find a better solution instead of a return. Please don't hesitate to contact us.

If the return is due to reasons other than the ones listed above, the customer will be responsible for the return shipping fees, if:

1. You are not satisfied with the product(s) after receiving the box(es).
2. You no longer need the product(s), but you have already received the box(es).
3. You purchased the product(s) by mistake, but you have already received the box(es).
4. Before picking up the package, please make sure that everything is returned to the original packaging and that the prior opening will not affect the reselling of the product.

You can try to get prepaid labels for UPS express return. Alternatively, we can provide prepaid shipping labels after you provide photos of the package before and after repackaging. Just stick the label on the box and call to pick it up.

When will I be refunded?

The refund will be issued once the goods have been received and processed at our warehouse. If you have any questions, please don't hesitate to contact us, and we will work with you to find a solution that ensures your satisfaction.